



Epson Stylus® Pro GS6000

SETUP AND USE GUIDE

All rights reserved. No part of this publication may be reproduced, stored in a retrieval system, or transmitted in any form or by any means, electronic, mechanical, photocopying, recording, or otherwise, without the prior written permission of Seiko Epson Corporation. The information contained herein is designed only for use with these Epson printers. Epson is not responsible for any use of this information as applied to other printers.

Trademarks

Epson, Epson Stylus, and MicroWeave are registered trademarks and Epson Exceed Your Vision is a registered logomark of Seiko Epson Corporation.

Epson UltraChrome is a trademark and Epson Preferred is a service mark of Epson America, Inc.

General Notice: Other product names used herein are for identification purposes only and may be trademarks of their respective owners. Epson disclaims any and all rights in those marks.

This information is subject to change without notice.

The ENERGY STAR emblem does not represent EPA endorsement of any product or service.

Legal Notices

Neither Seiko Epson Corporation nor its affiliates shall be liable to the purchaser of this product or third parties for damages, losses, costs, or expenses incurred by purchaser or third parties as a result of: accident, misuse, or abuse of this product or unauthorized modifications, repairs, or alterations to this product, or (excluding the U.S.) failure to strictly comply with Seiko Epson Corporation's operating and maintenance instructions.

Seiko Epson Corporation shall not be liable for any damages or problems arising from the use of any options or any consumable products other than those designated as Original Epson Products or Epson Approved Products by Seiko Epson Corporation.



FCC Compliance Statement

For United States Users

This equipment has been tested and found to comply with the limits for a Class A digital device, pursuant to Part 15 of the FCC Rules. These limits are designed to provide reasonable protection against harmful interference when the equipment is operated in a commercial environment. This equipment generates, uses, and can radiate radio frequency energy and, if not installed and used in accordance with the instruction manual, may cause harmful interference to radio communications. Operation of this equipment in a residential area is likely to cause harmful interference, in which case the user will be required to correct the interference at his own expense.

This device complies with Part 15 of the FCC Rules. Operation is subject to the following two conditions:

- (1) this device may not cause harmful interference, and
- (2) this device must accept any interference received, including interference that may cause undesired operation.

WARNING

The connection of a non-shielded equipment interface cable to this equipment will invalidate the FCC Certification of this device and may cause interference levels which exceed the limits established by the FCC for this equipment. It is the responsibility of the user to obtain and use a shielded equipment interface cable with this device. If this equipment has more than one interface connector, do not leave cables connected to unused interfaces. Changes or modifications not expressly approved by the manufacturer could void the user's authority to operate the equipment.

For Canadian Users

This Class A digital apparatus complies with Canadian ICES-003.

Cet appareil numérique de la classe A est conforme à la norme NMB-003 du Canada.

WARNING

This is a Class A product. In a domestic environment this product may cause radio interference, in which case the user may be required to take adequate measures.

Contents

Introduction

Warnings, Cautions, Notes, and Tips	9
Options and Supplies.	10
Where To Get Help.	11
Windows System Requirements.	11
Important Safety Instructions	12
Setting Up the Printer.	12
Using the Printer.	13
Handling Ink Cartridges	15
Handling Waste Ink	16

1 Setting Up the Printer

Unpacking and Assembling the Pro GS6000	17
Unpacking and Assembling the Stand	18
Installing the Printer on the Stand.	21
Installing the Auto Take-Up Reel	24
Removing the Printer Packing Materials	27
Connecting the Power Cord	31
Installing Ink	33
Installing Your Software.	37
Connecting to Your System	37
Updating Your Printer Firmware.	38
Checking the Current Firmware Version.	38
Downloading the Firmware.	38
Updating the Firmware	38
Configuring the Printer for Your Network.	39

2 Handling Media and Printouts

Selecting Media for Your Printer	41
Loading Media.	42
Placing the Roll on the Printer	43
Attaching the Media to the Auto Take-Up Reel	49
Checking the Print Quality	53
Adjusting the Print Head Height.	54

Setting Up Paper Configurations	56
Creating Paper Configurations	56
Printing a List of Your Paper Configurations.	57
Printing Using a Paper Configuration	57
Pre-Printing Checklist	58
Adjusting the Paper Feeding Position.	59
Aligning the Print Head.	61
Cutting Off Prints	62
Removing Prints From the Auto Take-Up Reel	64
Replacing Roll Media.	66

3 Maintaining the Printer

Checking the Ink Status	70
Checking the Printer Status	70
Printing Status Information.	71
Viewing Status Information.	71
Checking the Print Head Nozzles	73
Cleaning the Print Head	74
Replacing Ink Cartridges	75
Disposing of Waste Ink	78
Cleaning the Cleaning Wiper, Capping Assemblies, and Print Head Casings	79
Replacing the Flushing Pad	84
Washing the Ink System	86

4 Cleaning, Storing, and Transporting the Printer

Cleaning the Printer.	89
Storing the Printer	91
Moving or Transporting the Printer.	91
Moving the Printer on the Stand.	92
Preparing the Printer for Shipment	93

5 Solving Problems

Diagnosing Problems	99
Checking Error Messages and Lights	100
Solving Operational Problems	104
Improving Print Quality	105
Solving Media Problems	106
Clearing Media Jams	107

A Printer Parts and Controls Summary

Printer Parts	109
Control Panel Buttons and Lights	110
Buttons	110
Lights	111
LCD Display Icons	113
Menu Setting Summary	114
Paper Setup Option Summary	117
Using Maintenance Mode	120

B Specifications

Environmental	121
Electrical	121
Dimensions and Weight	122
Printer Interfaces	122
Safety Approvals	122
Media	122
Ink Cartridges	123

Index

Introduction

This *Setup and Use Guide* provides important information on setting up and using your printer, loading media, adjusting print quality, replacing ink cartridges, and maintaining the ink system. It also tells you how to clean and transport your printer, provides troubleshooting tips in case you have a problem, and lists your printer specifications.

For additional information, see the following:

- The *Quick Reference Guide* provides a handy summary of procedures for daily use and printer maintenance—loading media, replacing ink cartridges, cleaning and maintaining the printer and ink system, and keeping track of media types. Attach it to your printer for easy reference.
- The *Setup and Use Guide* is available for on-screen viewing on the printer software DVD and covers the same subjects as this book.

Warnings, Cautions, Notes, and Tips

Please follow these guidelines as you use this book:

WARNINGS must be followed carefully to avoid bodily injury.

Cautions must be observed to avoid damage to your equipment.

Notes contain important information about your printer.

Tips contain additional hints on how to get the most out of your printer.

Tip: Check the Epson Pro Imaging website at www.proimaging.epson.com for accessories and options that are currently available.

Options and Supplies

Your Epson Stylus® Pro GS6000 offers these optional upgrades:

Optional upgrades

Option	Part number
Additional One-year Epson Preferred SM Plus Service	EPPGS6KB1
Additional Two-year Epson Preferred Plus Service	EPPGS6KB2

In addition, you can order these supplies:

Consumables and user-replaceable parts

Part	Part number
Ink Cartridges	See page 75 for a complete list.
Additional Printer Maintenance Kit (one-year supply); see page 78	C12C890611
Additional Cleaning Cartridges (8 cartridges); see page 86	T623900
Print Head Cleaning Kit (used for periodic cleaning); see page 79)	C12C890621
Additional Waste Ink Bottle	CBOTTLE
Additional 64-inch Wide Media Take-up Core	C64CORE

We recommend you purchase a set of the Additional Cleaning Cartridges so you have them handy if you need them.

You can purchase optional equipment and genuine Epson ink and media from an Epson Professional Imaging Authorized Reseller. To find the nearest reseller, visit www.proimaging.epson.com (U.S. sales), www.epson.ca (Canadian sales), or call 800-GO-EPSON (800-463-7766). Or you can purchase online at www.proimaging.epson.com (U.S. sales) or www.epson.ca (Canadian sales).

Where To Get Help

Tip: If you experience difficulty with the toll-free line or your Unit ID number, call (562) 276-1305.

Epson provides technical support and information on the installation, configuration, and operation of professional printing products through the Epson Preferred Limited Warranty Plan. Dial (888) 377-6611, 6 AM to 6 PM, Pacific Time, Monday through Friday. Days and hours of support are subject to change without notice.

Before you call, make sure you have your Unit ID number, which is included with the Epson Preferred Limited Warranty Plan information that came with your printer. You'll also need your printer serial number and proof of purchase.

Visit Epson's support website at epson.com/support (U.S.) or epson.ca/support (Canada) and select your product for solutions to common problems. You can download drivers, firmware, and documentation, get FAQs and troubleshooting advice, or e-mail Epson with your questions.

Windows System Requirements

To use your printer in either a stand-alone (USB) or peer-to-peer network environment, your system should meet these requirements:

- IBM®-compatible PC with a Pentium® 4, 3 GHz or higher processor recommended
- Microsoft® Windows® Vista™ or Windows XP
- At least 1GB of RAM (2GB or more recommended)
- At least 30GB of free hard disk space for software and processing files
- Quad-speed (4×) DVD drive for installing the printer software
- For USB connection: a Windows-compliant USB Hi-Speed 2.0 port and a shielded USB “AB” cable from Series A (computer) to Series B (printer), up to 10 feet (6 m) long
- For Ethernet connection: Ethernet equipped PC and a Category 6 compatible cable

Caution: Using an improperly shielded cable—especially a cable more than 10 feet (6 m) long—may cause the printer to malfunction.

Note: USB 2.0 is required to run the printer at full speed.

Important Safety Instructions



Before using your printer, read the following safety instructions to make sure you use the equipment safely and effectively.

Setting Up the Printer

- The printer weighs about 331 lb (150 kg) without ink or paper. Make sure you have sufficient assistance when lifting it. See page 17.
- Select a location with adequate ventilation.
- Avoid locations exposed to air that is blown directly from a fan or air conditioner. Blown air may dry the ink in the print head nozzles causing reduced print quality.
- Avoid places subject to rapid changes in temperature and humidity. Also keep the printer away from direct sunlight, strong light, heat sources, and air conditioners.
- When setting up the printer, make sure you have enough space around it for sufficient ventilation.
- Place the printer on a flat, stable surface. The printer will not operate properly if it is tilted or at an angle.
- Avoid places subject to shocks and vibrations.
- Keep the printer away from dusty areas.
- Keep your entire computer system away from potential sources of electromagnetic interference, such as loudspeakers or the base units of cordless telephones.
- Place the printer near a wall outlet where the plug can be easily unplugged.
- Use only the type of power source indicated on the label.
- Connect the printer to a properly grounded outlet. Avoid using an outlet on the same circuit as a photocopier or air control system that regularly switches on and off.
- Avoid using electrical outlets controlled by wall switches or timers.
- Use only the power cord that comes with the printer. Use of another cord may result in fire or electric shock.

- The printer's power cord is designed for use with the printer only. Using it with other equipment may result in fire or electric shock.
- Do not use a damaged or frayed power cord.
- If you use an extension cord with the printer, make sure the total ampere rating of devices plugged into the extension cord does not exceed the cord's ampere rating. Also, make sure the total ampere rating of all devices plugged into the wall outlet does not exceed the wall outlet's ampere rating.

Using the Printer

Caution: Always turn the printer off using the  Power button. When you press this button, **POWER OFF** appears on the LCD panel and the  Power light flashes. Do not unplug the printer or turn off the power to the printer until the panel shuts off and the  Power light stops flashing. This ensures that the print head is safely capped.

- Do not block or cover the openings in the printer's case.
- Do not put your hand inside the printer or touch the ink cartridges during printing.
- Do not move the print head by hand unless instructed to do so by an Epson service technician; otherwise you may damage the printer.
- Do not touch the post heater during printing. It is hot and may cause a burn.
- Do not touch the paper feed slot, platen, or post heater while the heaters are operating. They are hot and may cause a burn.
- Do not touch the steel belt inside the printer; otherwise, you may be injured.

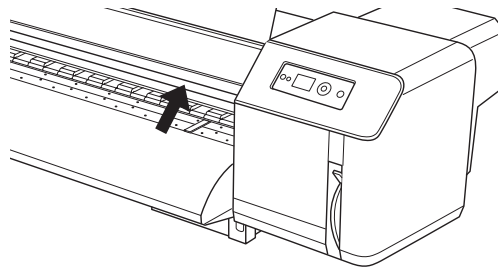

- Do not insert objects through the slots. Take care not to spill liquid on the printer.
- Do not use aerosol products that contain flammable gases inside or around the printer. Doing so may cause fire.

- Keep all combustible materials or liquids away from the printer. Exposure of these materials or liquids to the heated platen may cause a fire.
- Do not move the paper release lever unless instructed to do so. Moving the lever at the wrong time may cause the print head to touch the pressure rollers and cause a malfunction.
- When not using the printer for one week or more, clean the print heads once a week to preserve print quality. If the print head is not cleaned, it may get clogged.
- Clean the cleaning wiper once a month, or if blurs or gaps appear on printouts after cleaning the print head.
- Replace the flushing pad once a year, or if ink smears on your media or the pad becomes damaged.
- Take care not to spill waste ink from the flushing pad when replacing it. If waste ink gets on the grid roller beneath it, the ink may damage it and paper may not feed correctly.
- Clean the print head casing if dust or ink accumulates on it. If you do not clean it, print quality may decline.
- Do not bend or pull the waste ink drain tube. The ink may leak and damage the printer.
- Do not attempt to service the printer yourself.
- Power down the printer from the control panel, unplug the printer, and refer servicing to qualified service personnel under the following conditions: the power cord or plug is damaged; liquid has entered the printer; the printer has been dropped or the cabinet damaged; the printer does not operate normally or exhibits a distinct change in performance.
- The printer uses two power systems. Unplug both power cords before servicing the printer; otherwise there is a risk of electric shock.

For California customers only:

The lithium batteries in this product contain

Perchlorate Material - special handling may apply,

See www.dtsc.ca.gov/hazardouswaste/perchlorate.

Handling Ink Cartridges

- Keep ink cartridges out of the reach of children and do not drink the ink.
- Store ink cartridges in a cool, dark place.
- Handle the ink with care. Avoid having the ink come into contact with your skin, eyes, and clothing, and avoid accidental ingestion. Be careful not to inhale the vapors.
- If ink gets on your skin, wash well with plenty of soapy water. Consult your doctor if your skin feels irritated or is discolored.
- If ink gets in your eyes, flush them immediately with plenty of water and see a doctor as soon as possible.
- If ink is accidentally swallowed, do not vomit. Consult a doctor as soon as possible.
- Shake ink cartridges horizontally for about five seconds before unpacking and installing them for best results. If the cartridge has been installed previously, shake it very gently.
- Do not use an ink cartridge beyond the date printed on the cartridge.
- Use up the ink cartridge within six months of installation for best results.
- Do not dismantle ink cartridges or try to refill them. This could damage the print head.
- After bringing an ink cartridge inside from a cold storage site, allow it to warm up at room temperature for at least three hours before using it.
- If you remove an ink cartridge for later use, protect the ink supply area from dirt and dust, and store it in the same environment as this product. Note that there is a valve in the ink supply port, making covers or plugs unnecessary, but care is needed to prevent ink from staining items that the cartridge touches.
- Do not touch the ink supply port, its surrounding area, or the green IC chip on the side of the ink cartridge. Doing so may affect normal operation and printing.

Caution: Do not use too much force when you shake cartridges that have been previously installed.

Handling Waste Ink

- Before handling the waste ink, read the Material Safety Data Sheet (MSDS) for your printer. You can download it from Epson's support website at epson.com/support (U.S.) or epson.ca/support (Canada).
- The waste ink from the printer is industrial waste. Proper waste ink disposal in compliance with the industrial waste disposal laws and ordinances of your local government is required. Consign disposal of waste inks to an industrial waste disposer. Provide the Waste Ink Data Sheet to the industrial waste disposer. You can download it from Epson's support website at epson.com/support (U.S.) or epson.ca/support (Canada).
- Keep the workplace free from open flame and well ventilated while handling waste ink.
- Handle the ink with care. Avoid having the ink come into contact with your skin, eyes, and clothing, and avoid accidental ingestion. Be careful not to inhale the vapors.
- Wear a protective mask, eyewear, gloves, long sleeves, and long trousers to avoid contact with the ink during waste ink disposal. Work clothes that become soiled with the ink should be thoroughly cleaned.
- Wash your hands and gargle well after disposing of the ink.
- Do not bring food near the waste ink.
- Keep waste ink out of reach of children.
- If ink gets on your skin, wash well with plenty of soapy water. Consult your doctor if your skin feels irritated or is discolored.
- If ink gets in your eyes, flush them immediately with plenty of water and see a doctor as soon as possible.
- If ink is accidentally swallowed, do not vomit. Consult a doctor as soon as possible.
- If ink vapor is inhaled, move to clean air and consult a doctor if you feel dizzy or nauseous. If breathing stops, perform artificial respiration immediately and call for emergency medical service.
- If ink spills from the container, remove any sources of heat, sparks, or flames. Wipe up the ink with a cloth and soak used cloths in water until disposed along with any waste ink.

Chapter 1: Setting Up the Printer

This chapter includes the following information:

- Unpacking and assembling the Pro GS6000
- Installing the Auto Take-Up Reel
- Removing the printer packing materials
- Connecting the power cord
- Installing ink
- Connecting to your computer and network
- Updating the printer firmware
- Configuring the printer for a network

Unpacking and Assembling the Pro GS6000

WARNING: Six people are required to unpack and set up the printer.

Note: When choosing a place for the printer, leave adequate room for easy access and ventilation. Avoid locations subject to direct sunlight, excessive heat, humidity, or dust. Also avoid locations near potential sources of electromagnetic interference, such as loudspeakers, cordless phones, TVs, or air conditioners.

Before beginning assembly, make sure you have sufficient space to set up and use the printer. The following illustration shows the minimum space required for using the Pro GS6000:

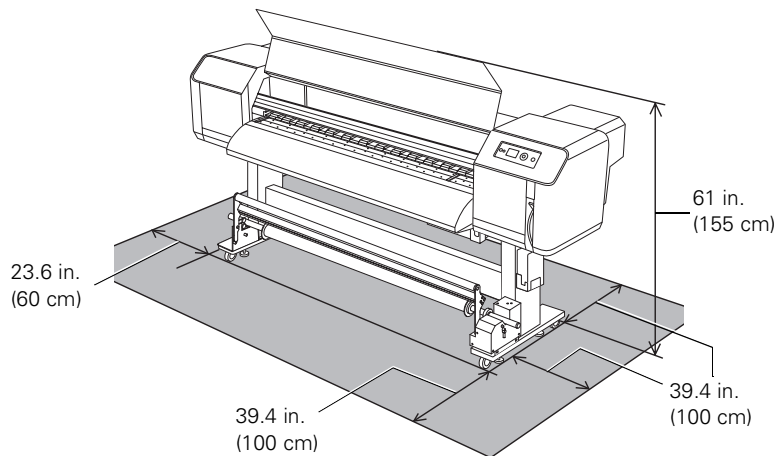

You need an even larger floor space to assemble the printer and stand, so be sure to prepare a large, clear area before unpacking them. Also make sure you save the box and packaging in case you need to ship the printer later.

Unpacking and Assembling the Stand

1. Unpack the stand and make sure you have all these items.

Note: You also need a long-handled Phillips-head screwdriver to assemble the stand.

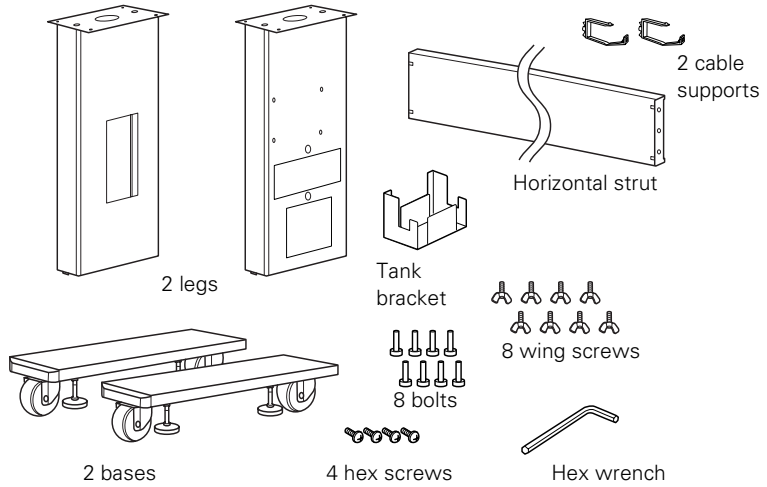

2. Insert the right leg into the right base (labeled with an R) as shown. Use the hex wrench to fasten the leg with the two bolts.

Note: You can also assemble the stand by placing the legs upside-down temporarily.

Make sure you tighten all bolts before moving to the next section.

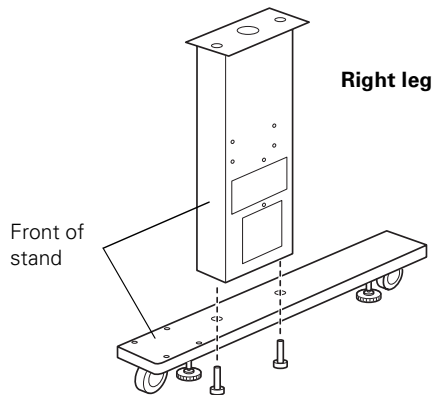

3. Assemble the left leg and base in the same way.

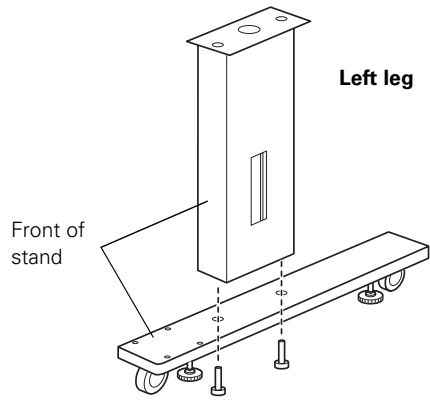

4. Attach the horizontal strut as shown, then fasten it with two bolts at each end.

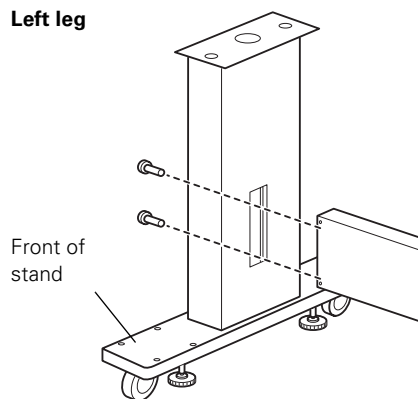
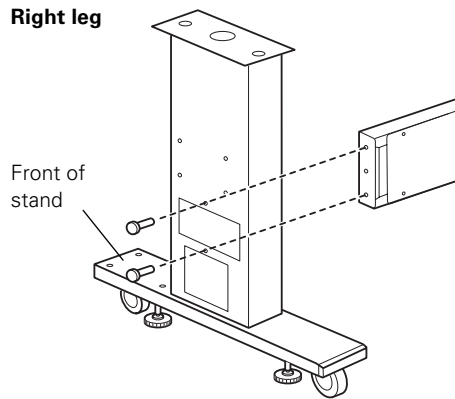

5. Attach the bracket for the waste ink tank to the outside of the right leg using the four hex screws.

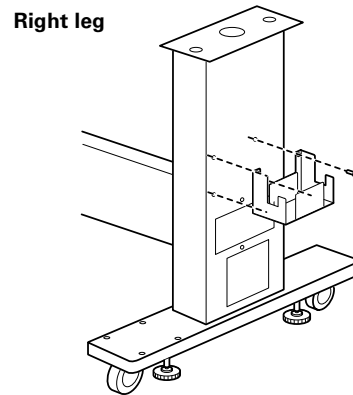

6. Make sure all of the screws are tightened securely.
7. Rotate the feet clockwise to stabilize the stand before installing the printer on it.

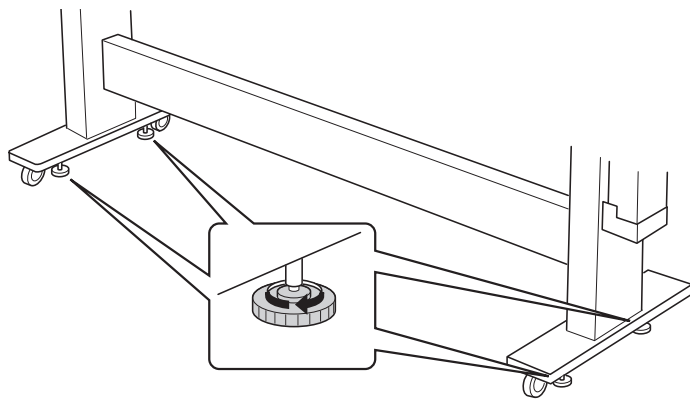

Installing the Printer on the Stand

Caution: Do not remove the packing tape from the printer at this point. The tape holds the printer parts in place as you complete installation.

Do not lift the printer from beneath the black plastic areas in back; lift it from the metal area in the middle.

WARNING: Six or more people are required to lift the printer.

1. Have six people lift the printer onto the stand. If you like, you can lift the printer using two 1-inch × 84-inch steel pipes (available at hardware stores). Insert the pipes into the guides beneath the printer.

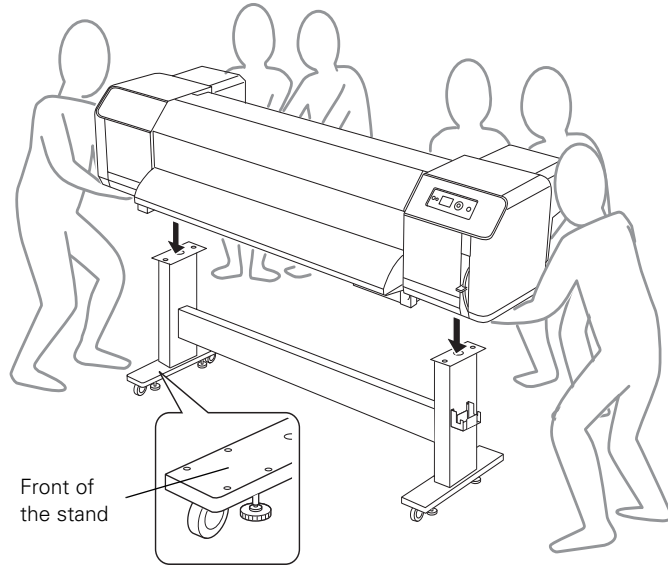

Carrying bar method

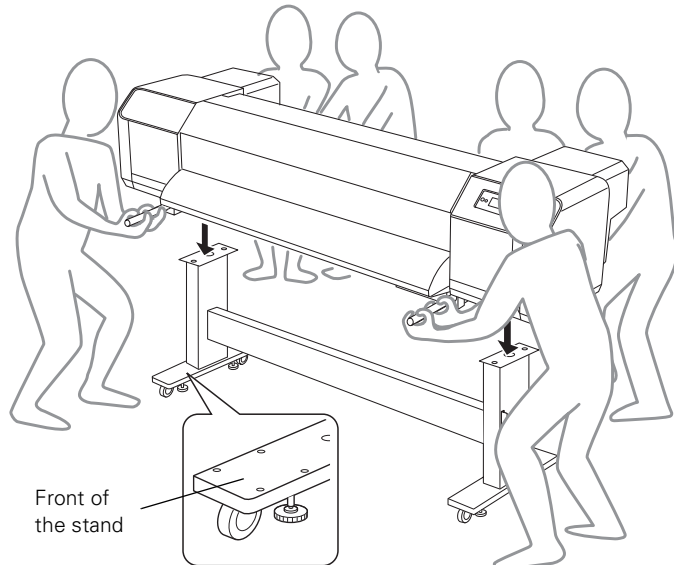

Be careful not to damage the waste ink connector and tube hanging beneath the printer as you place it on the stand.

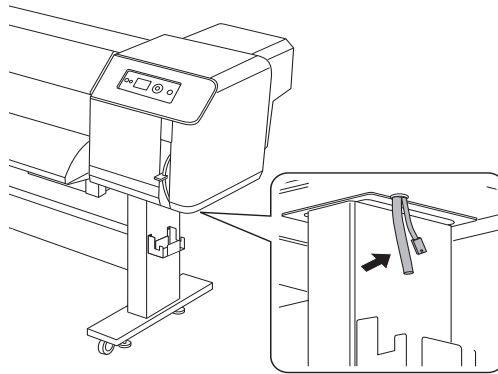

2. Attach the printer to the stand using the four wing screws.

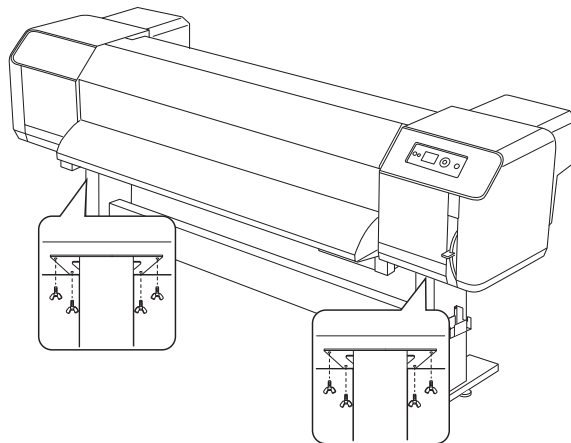

- Place the waste ink tank into the bracket on the stand and close the spigot valve all the way, as shown.

Caution: Make sure you close the spigot valve all the way to prevent spills.

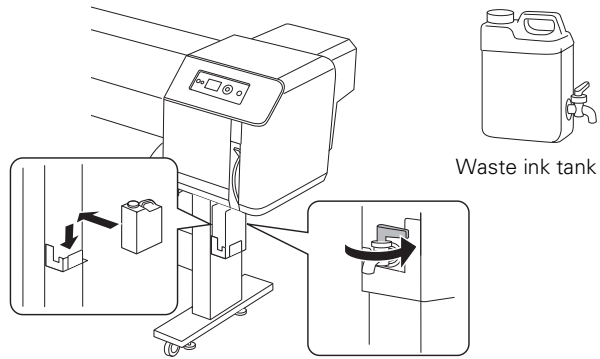

- Remove the plastic from the ends of the waste ink tube and sensor cable. Then connect the sensor cables and securely attach the waste ink tube to the tank.

Caution: Make sure you remove the plastic from the end of the tube or waste ink may be unable to drain and may back up into the printer.

Also make sure to securely attach the tube to the tank to prevent spills.

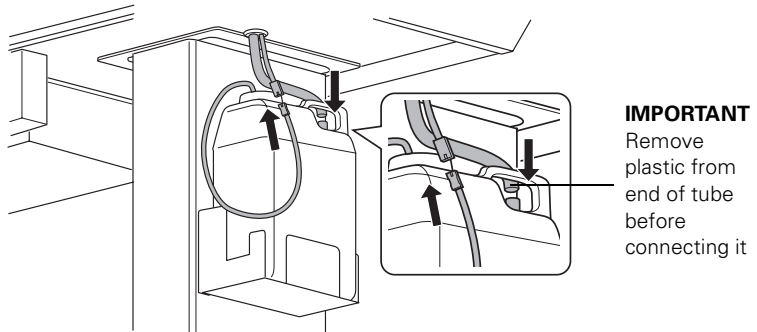

Be careful not to crimp the waste ink tube as you attach it.

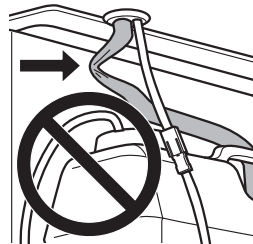

Installing the Auto Take-Up Reel

1. Make sure you have all the items shown below in the Auto Take-Up Reel box:

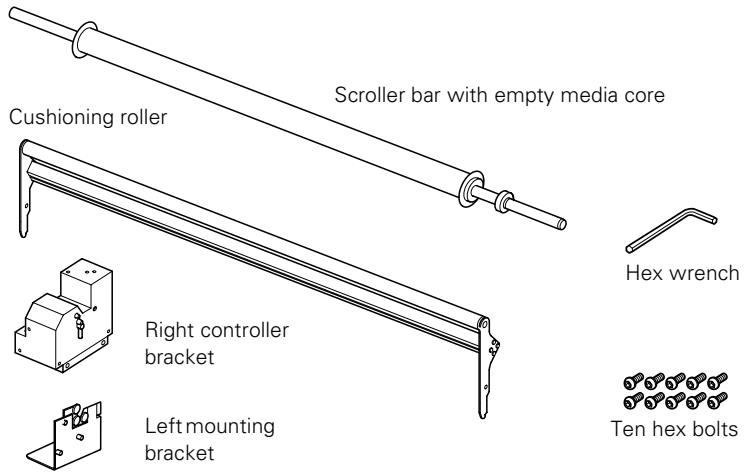

2. Loosen the four screws securing the mounting plate to the right controller bracket, then remove the bracket.

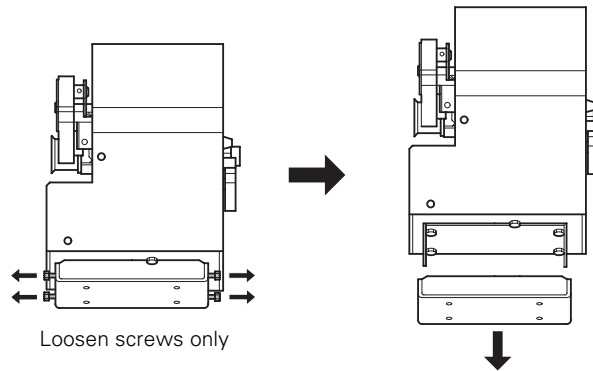

3. Install the mounting bracket on the right base of the stand and secure it with four hex bolts using the hex wrench.

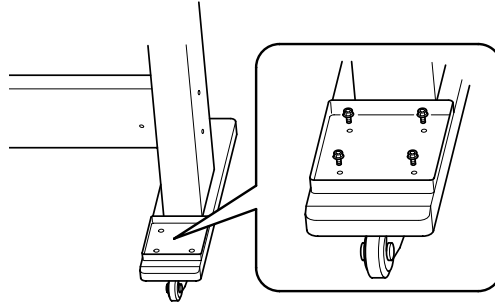

4. Install the right controller bracket on the mounting bracket as shown, then tighten the screws.

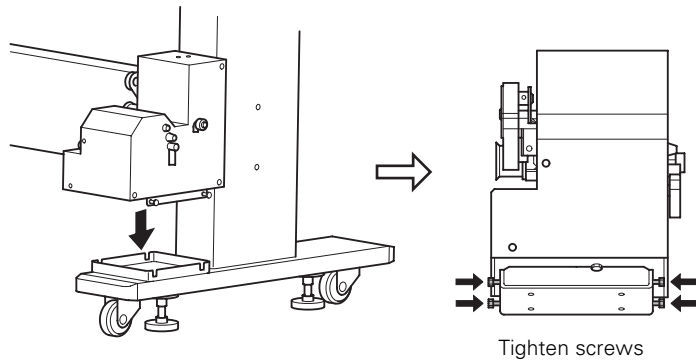

5. Install the left mounting bracket onto the left base of the stand as shown, then secure it with four hex bolts.

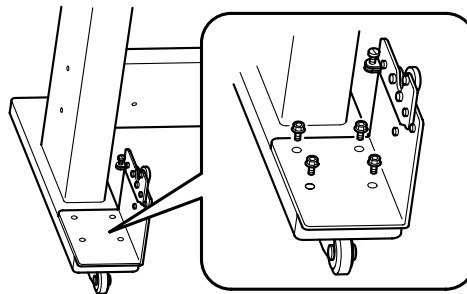

6. Hold the cushioning roller as shown and slide the left end onto the post on the left mounting bracket.

Caution: Make sure the tip of the cushioning roller bracket sits **between** the rubber stoppers.

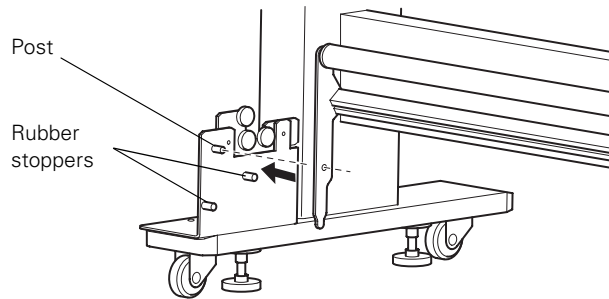

7. Slide the right end of the cushioning roller bracket onto the post on the right controller. Rotate the post base to align the holes, then secure the bracket using two hex bolts.

Caution: Do not adjust the third bolt that is already attached to the right controller.

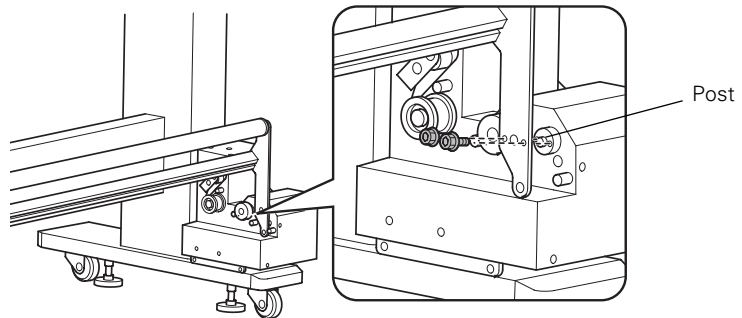

8. Place the right end of the scroller bar (the end with the metal collar) down between the rollers in the right controller. Then place the other end between the white rollers on the left mounting bracket. Make sure the scroller bar rests between the rollers at each end.

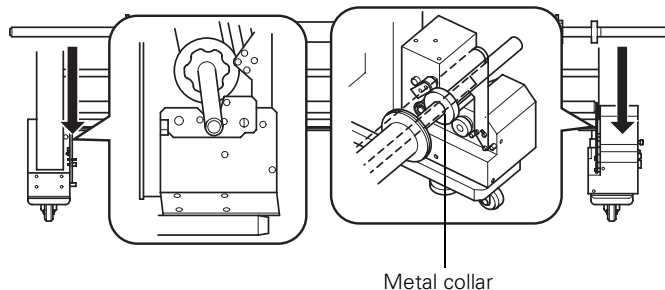

Removing the Printer Packing Materials

Now you can remove the packing materials from the printer.

1. Remove all the tape and coverings from the printer.

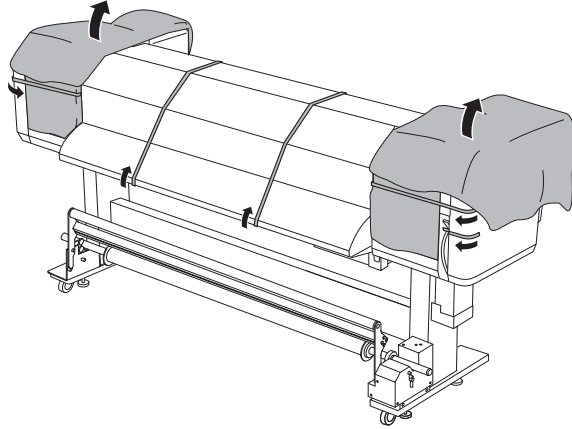

2. Press in on the top of the maintenance covers to open them, then lift them off of the printer, and remove the protective coverings.

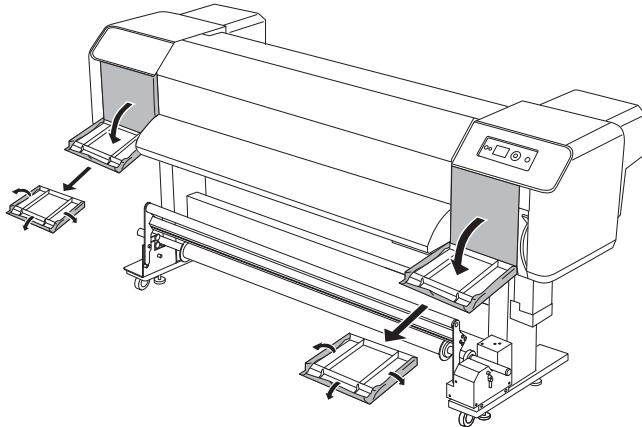

3. Place the maintenance cover hinges back in their slots and close the covers.

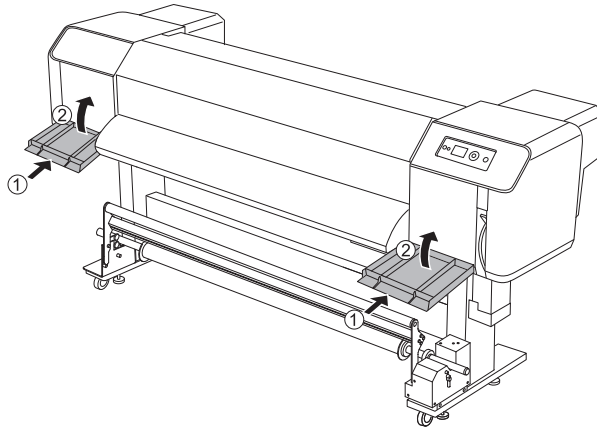

4. Remove any tape securing the back parts of the printer.

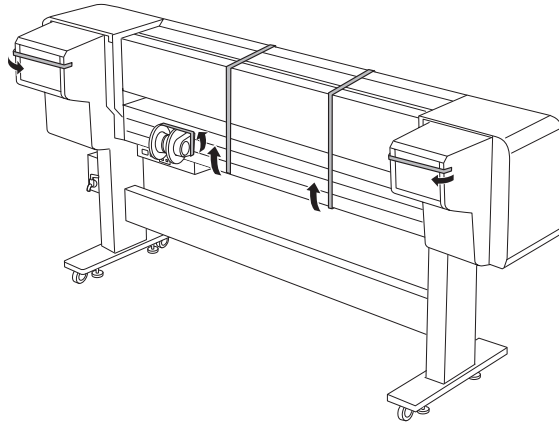

5. Open the front cover. Then remove the tape securing the paper holder plates, and the tape and brackets securing the carriage rail.

Caution: Remove the tape and brackets from the carriage rail slowly and carefully to avoid letting the tape touch any other part of the carriage.

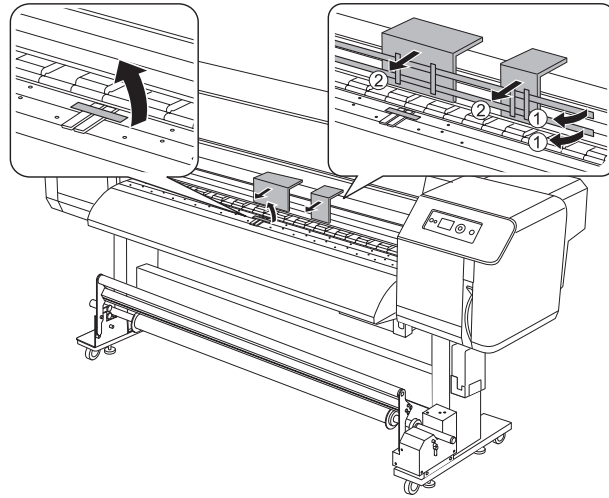

6. Remove **both the bolt and bracket** securing the print head. Save the bolt and bracket in case you need to ship the printer.

Caution: Be sure to remove both the bracket and the bolt from the print head.

To prevent paper jams, don't place the bolt back in the printer.

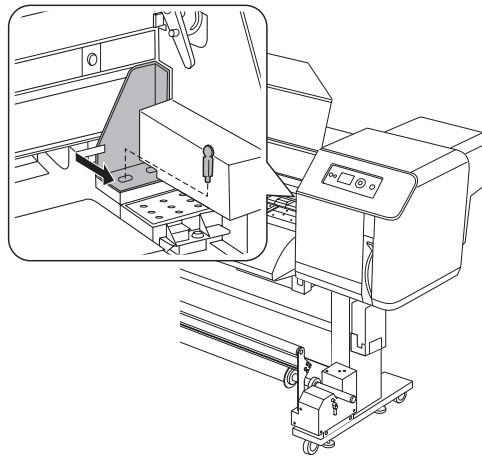

7. Attach the two cable supports to the leg of the stand as shown.

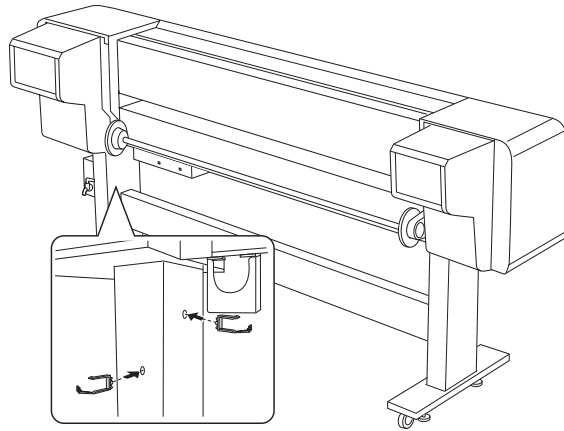

8. Rotate the feet counter-clockwise to raise them, then move the printer to the place of use. (Be sure to rotate the feet clockwise to stabilize the printer after moving it.)

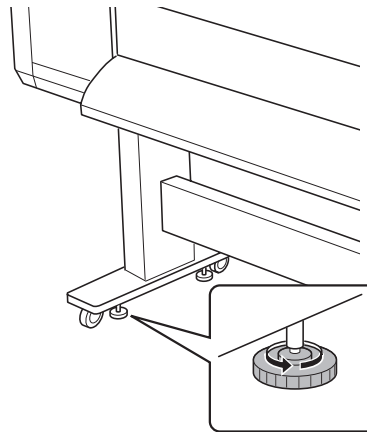

Caution: The printer requires 22 Amps of power. Make sure the outlet provides that power or plug the cables into two different outlets.

Do not use an outlet that is controlled by an automatic timer or wall switch. Otherwise, you may accidentally shut off the printer and cause damage.

Connecting the Power Cord

You need to use the two power cords that came with the printer and the third power cord that came with the Auto Take-Up Reel to power the printer.

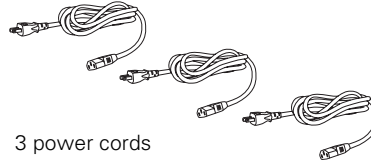

1. Route the two printer power cords through the cable supports as shown.

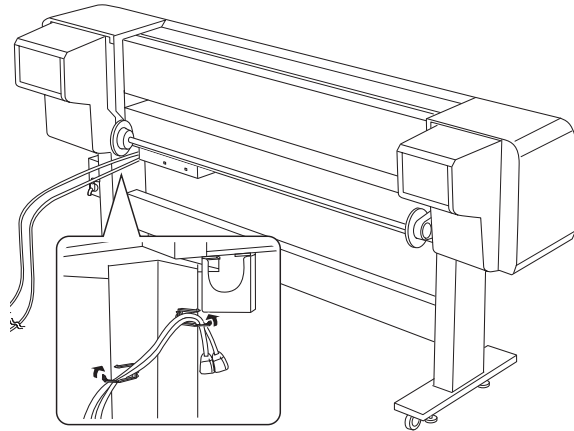

2. Connect the two power cords to the AC inlets on the back underside of the printer. Then connect them to a properly grounded electrical outlet.

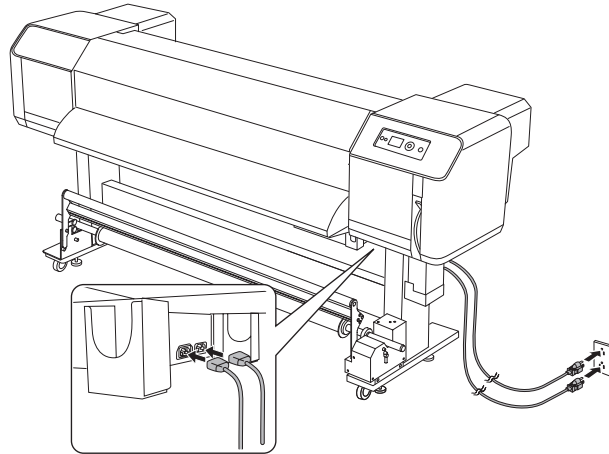

3. Turn off the Auto Take-Up Reel using the power switch on the back, then plug its power cord into its AC inlet and into an electrical outlet.

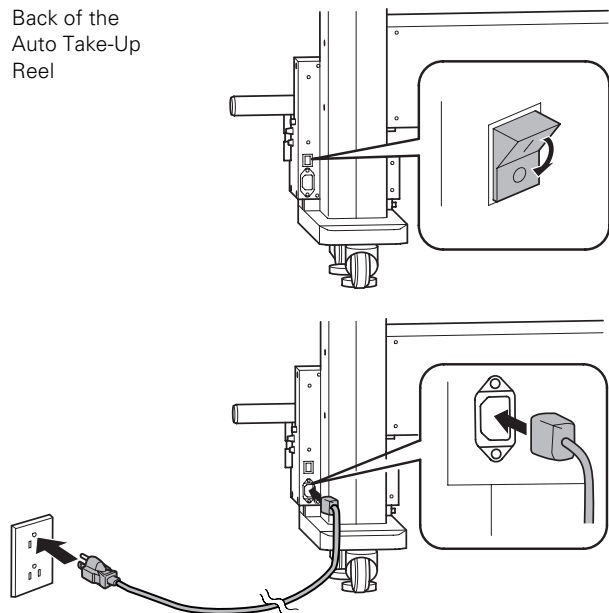

Installing Ink

Use the cleaning and ink cartridges that came with your printer for initial ink charging.

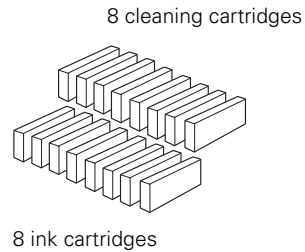

During initial installation, it is normal for a significant amount of ink to be used in each cartridge. Make sure you order a set of cartridges as soon as possible.

First you install the cleaning cartridges, then you remove them and install the ink cartridges when messages on the LCD display instruct you to do so.

1. Press the  Power button to turn on the printer. In a moment, **INSTALL NEW CLEANING CARTRIDGES** appears on the LCD display.

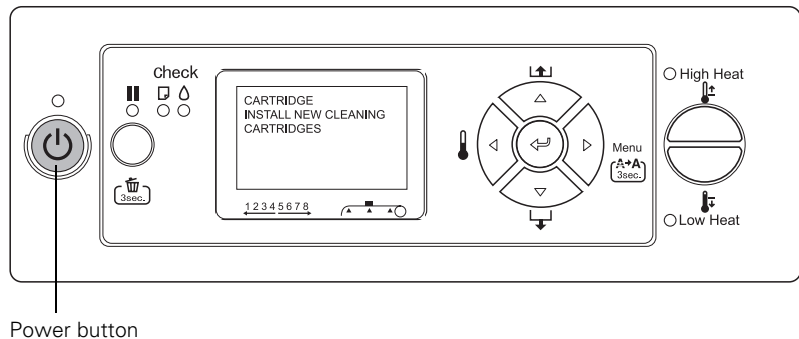

Caution: Be sure to install the cleaning cartridges, not the ink cartridges, at this point. **Follow the instructions on the LCD display.**

2. Open the packages containing the cleaning cartridges.

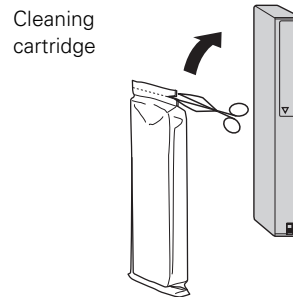

Note: You need to be present during the ink installation process. Do not leave the printer unattended.

3. Open both ink cartridge compartment covers on the back of the printer, insert the cleaning cartridges as shown, and close the covers.

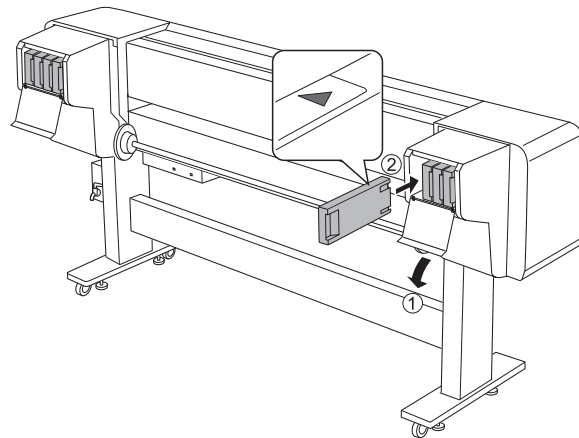

4. Follow the instructions on the LCD display to check the status of the waste ink tank.

The printer processes the cleaning cartridges for about eight minutes while **CLEANING** appears on the LCD display.

WARNING: Before handling the used cleaning cartridges, read the Material Safety Data Sheet (MSDS) for your printer. You can download it from Epson's support website at epson.com/support (U.S.) or epson.ca/support (Canada).

The waste ink from the printer is industrial waste. Proper waste ink disposal in compliance with the industrial waste disposal laws and ordinances of your local government is required. Consign disposal of waste inks to an industrial waste disposer. Please provide the Waste Ink Data Sheet to the industrial waste disposer. You can download it from Epson's support website at epson.com/support (U.S.) or epson.ca/support (Canada).

- When **REMOVE ALL CARTRIDGES** appears on the LCD display, open the ink cartridge compartment covers, remove the cleaning cartridges, and close the covers.

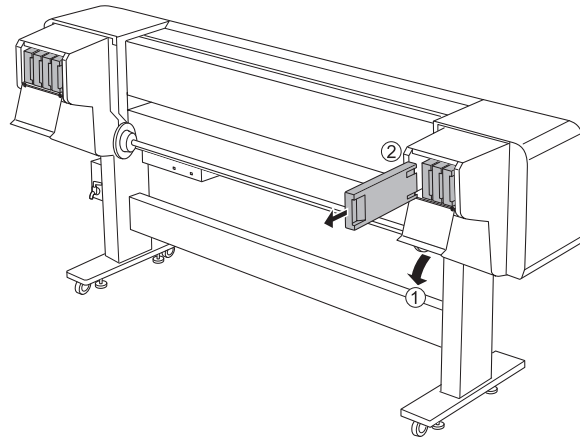

The printer drains the ink system for about 12 minutes while **DRAINING** appears on the LCD display.

- Dispose of the cleaning cartridges in compliance with industrial waste disposal laws and local government ordinances as required in your area.
- When **INSTALL INK CARTRIDGE** appears on the LCD display, vigorously shake each ink cartridge in its package for about five seconds, then remove the cartridges from their packages.

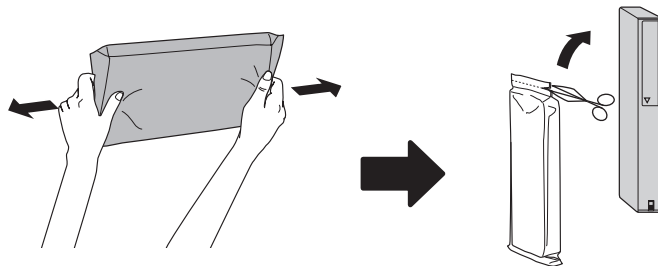

- Open both ink cartridge compartment covers on the back of the printer, insert the ink cartridges in the correct compartments as shown, and close the covers.

#8 #7 #6 #5 #4 #3 #2 #1
Cyan, Magenta, Yellow, Black Light Cyan, Light Magenta, Green, Orange

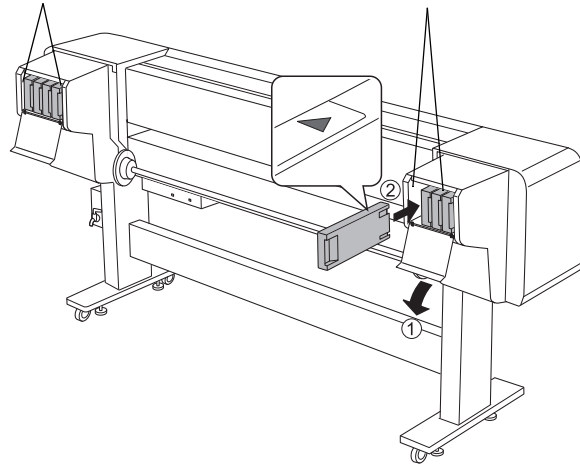

Caution: Charging takes about 18 minutes. Never turn off the printer, release the paper lever, or open the front cover while ink is charging, or you may damage the printer.

The printer charges the ink delivery system for about 18 minutes while **CHARGING INK** appears on the LCD display.

Charging is finished when the **PAPER OUT LOAD PAPER** message appears.

To load paper, see page 42.

Installing Your Software

Follow the instructions in the DVD package that came with your printer to install the software included on the DVD.

Connecting to Your System

You can use USB and/or Ethernet network connections.

For USB connection, make sure your system has the appropriate port and you have a standard, shielded cable 10 feet (6 m) long or less. Do not connect the printer until a software installation screen prompts you to.

To connect to a network hub, you need a standard RJ-45 CAT-6 network cable. To connect directly to your computer's network interface, you need an RJ-45 CAT-6 crossover cable.

1. Plug the interface cable into the appropriate port on the printer.

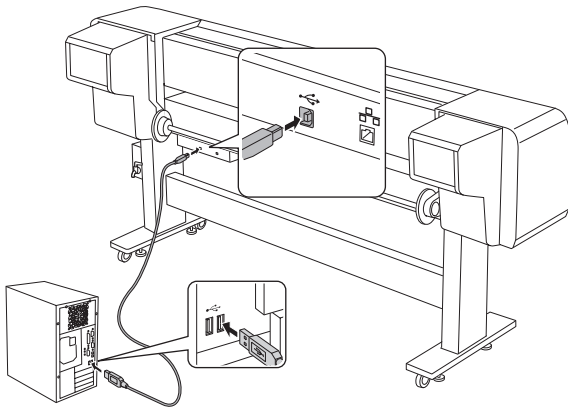

USB connection

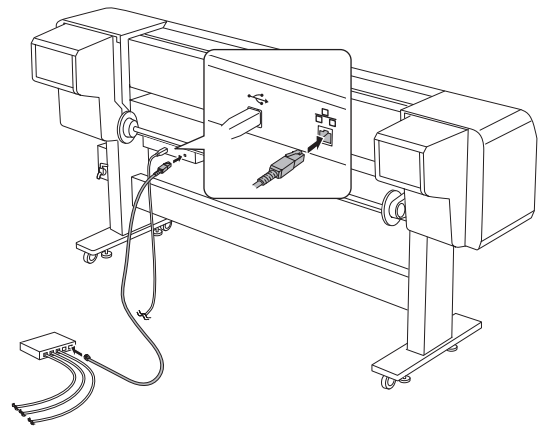

Network connection

2. Plug the other end of the cable into the appropriate connector on your computer, or network switch or hub.
3. Route the interface cable through the lower cable support on the printer stand along with the power cords, as shown on page 31.

Updating Your Printer Firmware

To keep your printer features and functionality up to date, you should check for a newer version of firmware on the Epson support site and update your printer, if necessary.

Checking the Current Firmware Version

Tip: For best results, use a USB connection when you update the printer firmware.

1. Press the **Menu** button.
2. Press the **▼** button until **PRINTER STATUS** is highlighted, then press **Menu**.
3. Press **Menu** again and note the firmware version displayed. When done, press the **||** **Pause** button.

Downloading the Firmware

1. Visit Epson's support website at epson.com/support and select your product.
2. Click **Drivers & Downloads**.
3. Choose the firmware update version for Windows and follow the instructions on the screen.

You may also need to download the latest version of the EPSON LFP Remote Panel utility.

Note: For more information on using the LFP Remote Panel, click **Help** to see the on-screen guide.

After you install the software, you need to load paper and print a test image. If the print quality is satisfactory, your setup is done. If not, you may need to align the print head, as described on page 61.

Updating the Firmware

1. Double-click the firmware file to extract it.
2. Click the **EPSON LFP Remote Panel** icon on your desktop. You see the LFP Remote Panel. Make sure your printer is selected.
3. Click the **Firmware Updater** button.
4. Click one of the **Update** buttons. You see the Firmware Updater window.

Caution: Don't turn off the printer while the firmware is updating.

5. Make sure your printer is turned on, its LCD displays **READY**, and it is connected to your computer or network, then choose your printer.
6. Click **Browse** and find the firmware file that you just downloaded and extracted. Select the file and click **Choose**.
7. If the firmware version of the file is newer, click **Update** to start the firmware updating process. (If it is the same, you don't need to update.)
8. When the update is complete, close the Firmware Updater window and Epson LFP Remote window.

If you connected your printer to a network, follow the instructions in the next section to configure the printer for your network.

Configuring the Printer for Your Network

Once the printer is connected to your network, follow these steps to configure it:

1. Turn on the printer.
2. Start EpsonNet Config.

The EpsonNet Config program searches for all Epson printers on the network and displays the MAC address for each printer that it finds.



3. Highlight the printer that you want to configure and click **Configuration** to access the TCP/IP selection screen.
4. If necessary, contact your network administrator for instructions on assigning an appropriate IP address.

Chapter 2: Handling Media and Printouts

The Epson Stylus Pro GS6000 prints on a variety of roll media in widths from 12 to 64 inches (300 to 1625 mm).

This chapter includes the following information:

- Selecting media for your printer
- Loading media
- Checking the print quality
- Adjusting the print head height
- Setting up paper configurations and print using them
- Adjusting the feeding position
- Aligning the print head
- Controlling media curl
- Cutting off prints
- Removing prints from the Auto Take-Up Reel
- Replacing roll media

Selecting Media for Your Printer

The Epson Stylus Pro GS6000 prints on a variety of solvent media products up to 64 inches (1625 mm) in width. Unlike other Epson Stylus Pro printers, Epson is not the primary media provider for this class of printers. Our goal is to partner with the industry leaders in solvent media and work with them to assure compatibility.

There are a large variety of media selections offered by each of our media partners. You can select from a full range of vinyls, banners, films, fabrics, and specialty media, as well as a wide selection of protective overlamine materials. All products are readily available in the market and all of our Epson Stylus Pro GS6000 resellers carry products from these companies.

In addition to the solvent media available from our partners, Epson will offer a few solvent media products that will optimize image and output quality for specialty applications. Please check <http://www.proimaging.epson.com> to see a list of Epson Stylus Pro GS6000 media and to find links to our partner's websites.

The following table lists the paper sizes you can use:

Media width	12 to 64 in. (300 to 1625 mm) wide
Core diameter	3 in. core
Maximum external roll diameter	6.7 in. (170 mm)
Maximum roll weight	66 lb (30 kg)
Maximum thickness	0.01 in. (0.3 mm); Low head height adjustment 0.05 in. (1.3 mm); High head height adjustment

Always test samples of media in the printer before purchasing large quantities or printing large jobs. See page 56 for instructions on setting up paper configurations.

Loading Media

Follow these guidelines, as well as those included in your media package, when handling media:

WARNING: Do not touch the post heater, paper feed slot, or platen during printing, or while switching media when the heaters are operating. These areas are hot and may burn you.

- Roll media is heavy, so two people are required to load it onto the printer.
- Avoid touching the printable surface with your bare hands. Fingerprints may affect print quality. Handle media by the edges or use cotton gloves.
- Be careful not to bend or scratch the media.
- Keep unused media in its original packaging and store it in a cool, dry place to maintain quality. Avoid storing your printouts where they will be exposed to high temperature, humidity, or direct sunlight.

Placing the Roll on the Printer

1. Make sure the printer is turned on. PAPER OUT. LOAD PAPER appears on the LCD display.
2. Make sure the ⏻ Power light is not flashing, then release the paper lever. LEVER RELEASED appears on the LCD display.

Caution: Do not release the paper lever while the ⏻ Power light is flashing, or you may damage the printer.

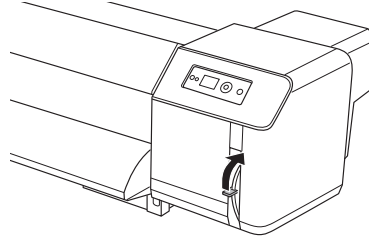

3. Flip up the levers to release the roll paper holders on the back of the printer, then slide the holders apart.

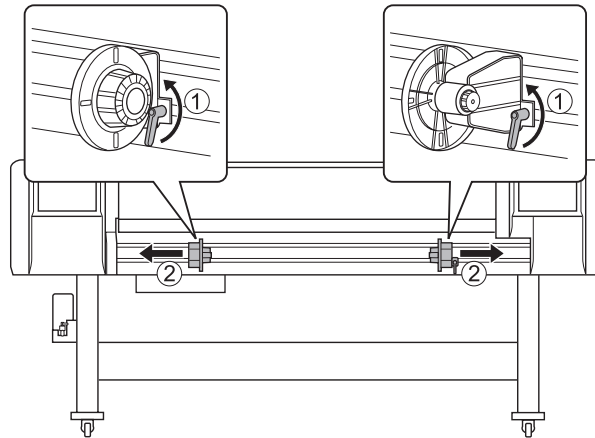

- Slide the left holder all the way left and flip the lever all the way down to lock it in place. Then place the left end of the roll media on the holder.

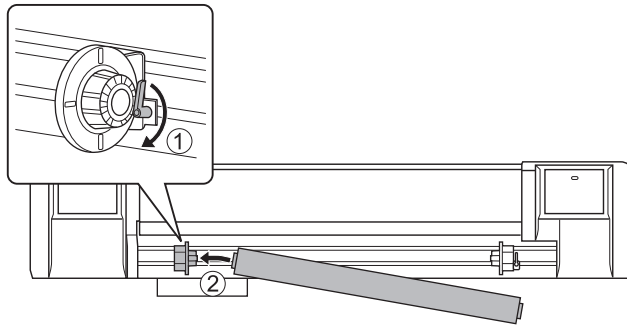

Orient the roll based on the printable side of the media:

Printable side out

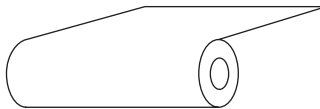

Printable side in

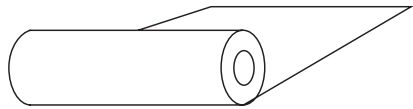

- Slide the right holder onto the right end of the roll media as shown. Then flip the lever all the way down to lock the holder in place.

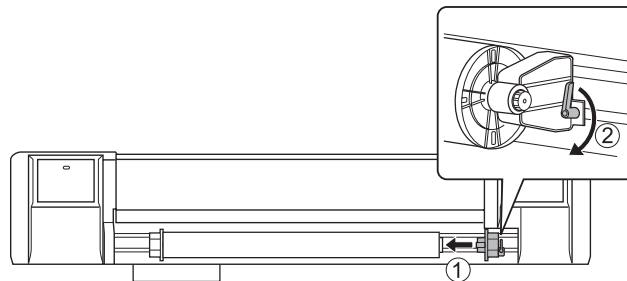

6. To center the roll, release both roll holder levers, move the center of the roll to the ▼ mark on the printer, and flip the levers all the way down.

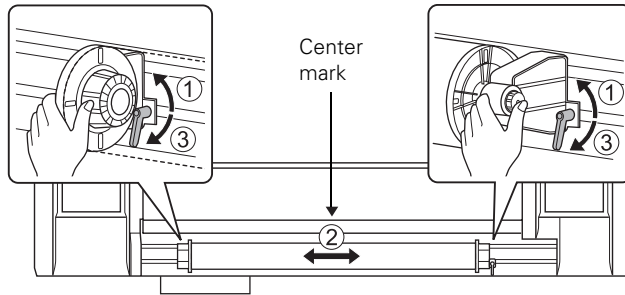

7. Open the front cover.

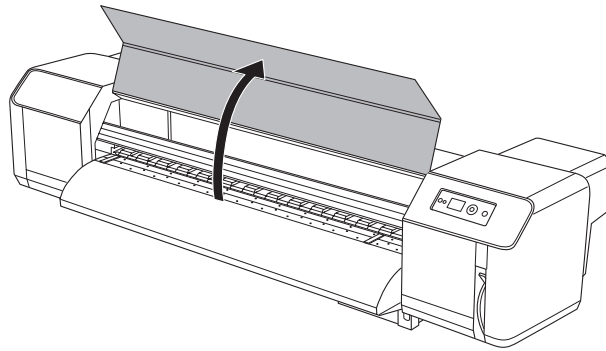

8. At the back of the printer, carefully feed the roll media into the slot and beneath the guides. Feed it all the way through to the front of the printer, keeping the roll tightly wound.

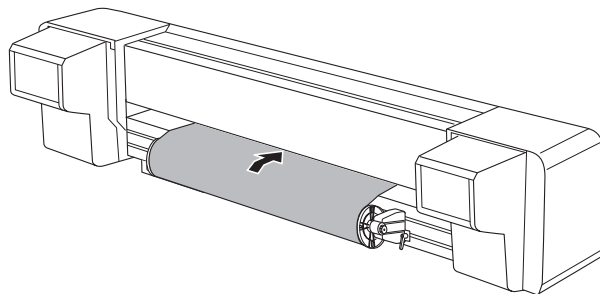

9. Pull the media out from the front about 3 ft (1 m).

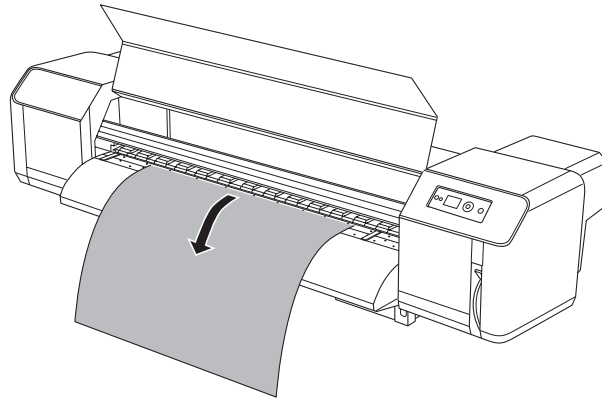

10. Turn the roll backward using the roll paper holders to remove any slack. Also make sure the edge of the media does not extend beyond the media limit line, indicated by a row of dots on the post heater.

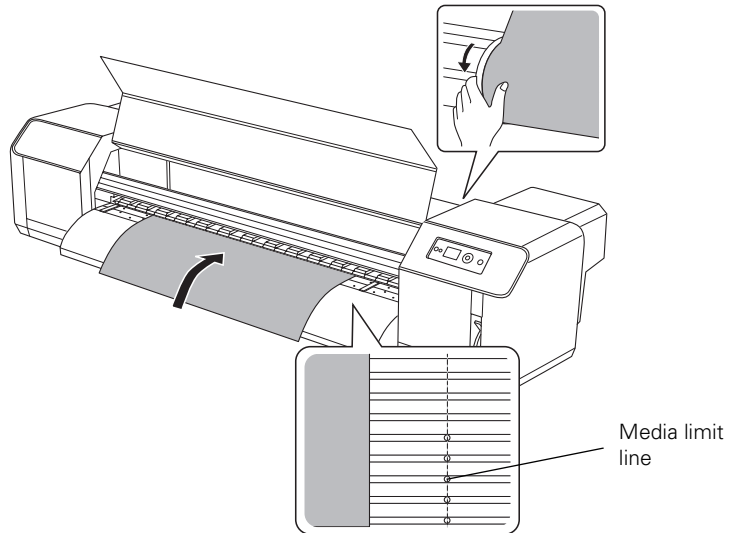

11. Check the position of both edges of the media in relation to the clear rubber pressure rollers. Each edge should be at least 0.2 inch (5 mm) away from the edge of the nearest pressure roller, as shown.

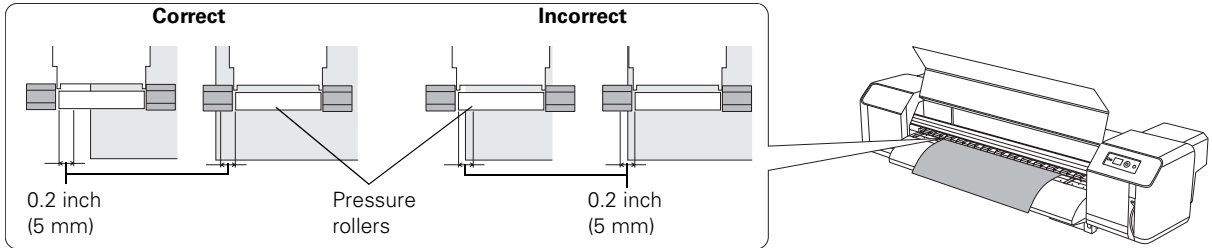

If you need to adjust the media's horizontal position, release both roll holder levers, move the media and holders as necessary, and lock the levers in place.

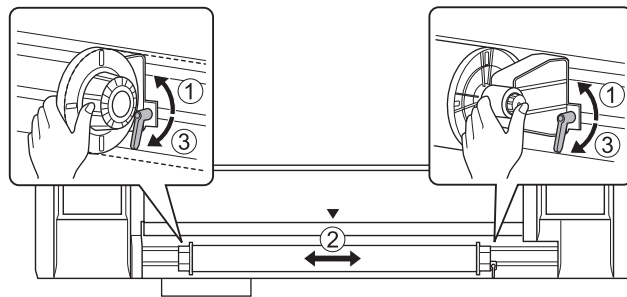

12. If you loaded thick media, you may need to adjust the platen gap (head height) setting. See page 54 for instructions.

- Slide the paper holder plates over both edges of the media as shown.

Caution: If the paper holder plates interfere with printing, they may become deformed and cause paper jams or damage to the print head. If the plates become damaged, stop using the printer and contact Epson.

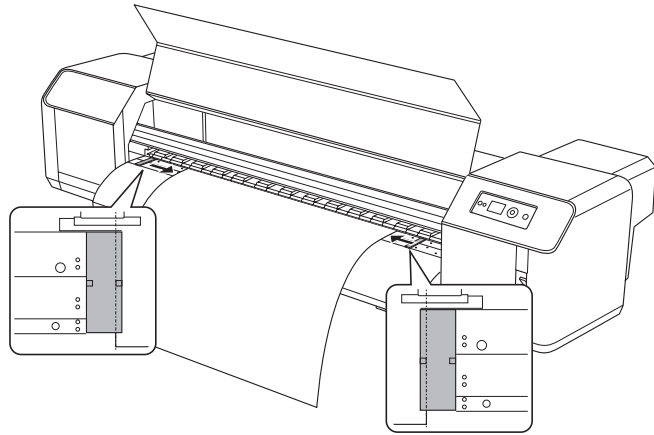

Note: To secure most media, move the paper lever to the **Secured** position. Use **High Secured** only if you have problems with print quality after adjusting the paper feed position. See page 59 for details.

- Move the paper lever to the **Secured** position.

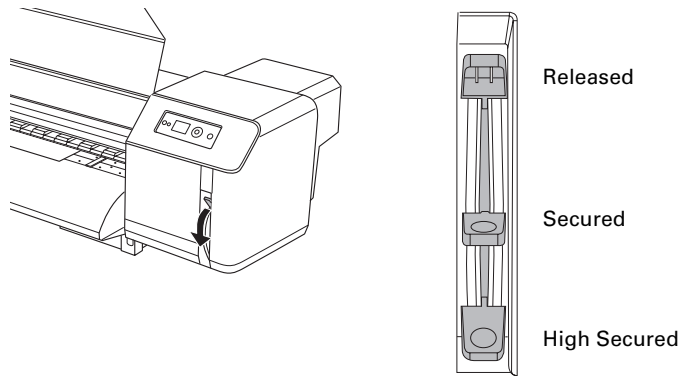

- Close the front cover.

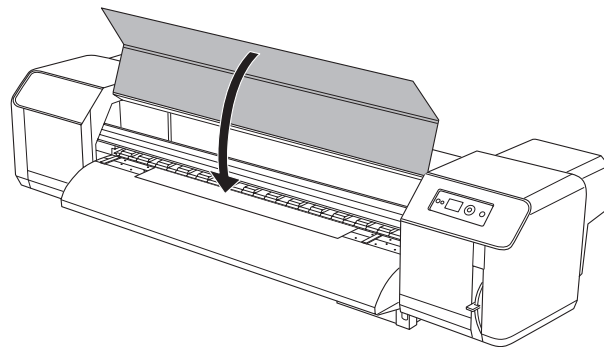

Note: To avoid denting or creasing the media, do not leave it loaded in the paper path for long periods. Remove it from the paper path and roll it up when you are not printing.

After a moment, **READY** appears on the LCD display.

16. If you will use the Auto Take-Up Reel to roll up your printed media, go to the next section.

If you will not use the reel, go to page 53 to check the print quality.

Attaching the Media to the Auto Take-Up Reel

You can use the Auto Take-Up Reel to roll up your printed media so it does not feed onto the floor.

Make sure you have placed an empty media core on the Auto Take-Up Reel scroller bar before loading media.

1. Turn on the Auto Take-Up Reel using the power switch on the back.

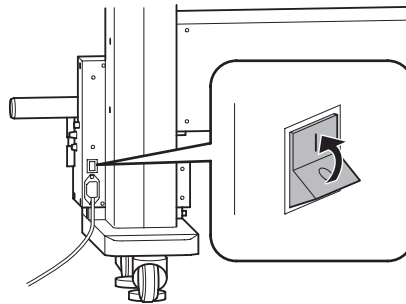

2. Set the switch on the top of the reel controller to **OFF**.

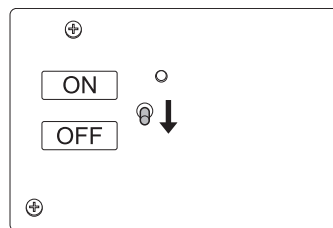

3. Move the paper lever to the **Released** position so you can pull the media down to the Auto Take-Up Reel.

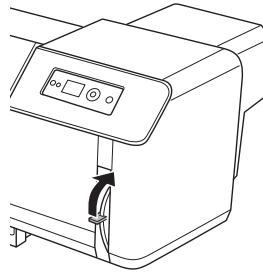

4. If the media is not positioned in the center of the empty take-up core, adjust the core's horizontal position using the adjustment knob on the side of the Auto Take-Up Reel controller. Turn the knob clockwise to move the core left, or counter-clockwise to move the core right.

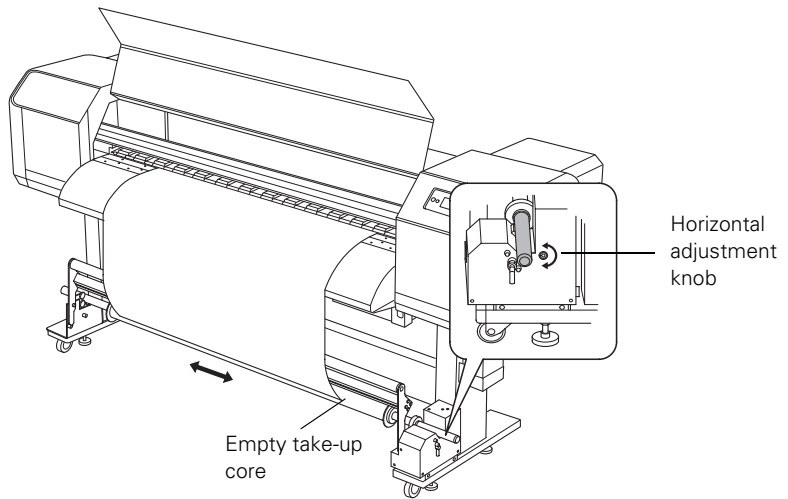

Note: If you see a **PAPER OUT** or **PAPER SKEW** error due to media rolling up crooked on the Auto Take-Up Reel, try trimming the edges of the media before taping it to the core.

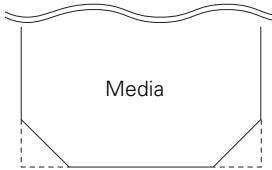

5. Make sure the media lays over the cushioning roller and onto the core, then tape the edge to the center of the core.

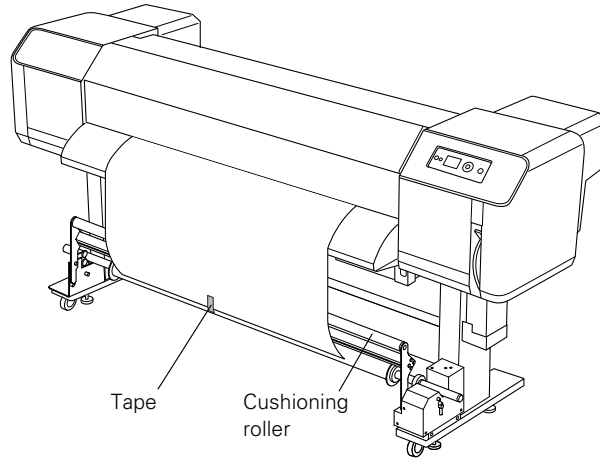

6. Flip the scroller release lever up to the **FREE** position.

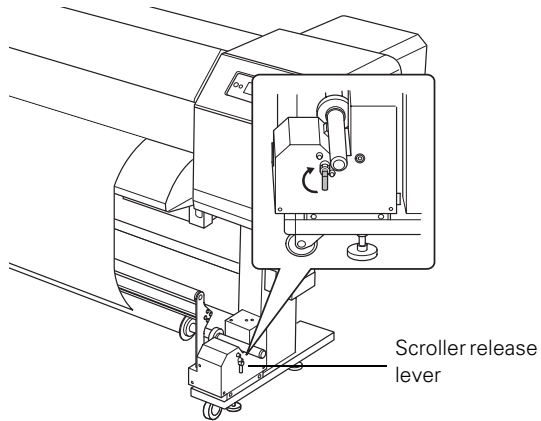

7. Turn the scroller counter-clockwise to take up the media one and a half rotations.

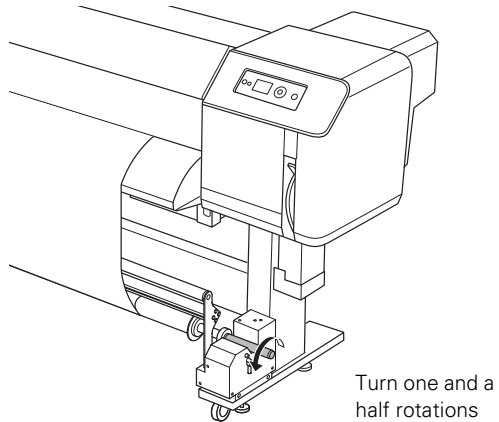

8. Flip down the scroller release lever to the **SET** position, then pull the cushioning roller all the way forward.

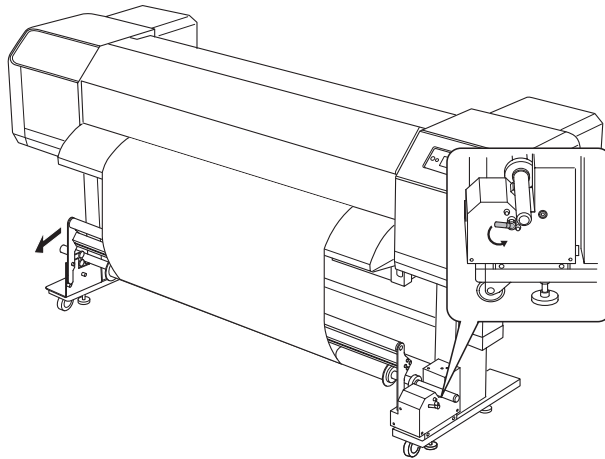

- Set the switch on the top of the reel controller to ON.

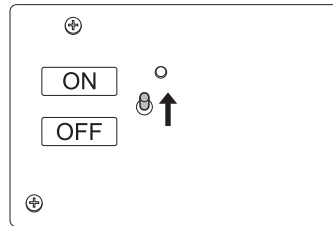

- Set the paper release lever to the **Secured** position.
- When **READY** appears on the LCD display, press the **Menu** button.
- PRINTER SETUP** is highlighted. Press **Menu** again.
- Press **▼** to select **AUTO TAKE-UP REEL**, press **Menu**, and select **ON**.
- Press the **||** Pause button to exit the menus.

Note: Before printing without the Auto Take-Up Reel, be sure to set the **AUTO TAKE-UP REEL** setting to **OFF**.

Now you can check the print quality as described in the next section.

Checking the Print Quality

When you first set up the printer, it's a good idea to run a nozzle check to test the print quality.

- Press the **Menu** button, press **▼** to highlight **TEST PRINT**, and press **Menu** again.
- Select **NOZZLE CHECK**, press **Menu**, and press **↵** to print a nozzle check pattern.
- Examine the printed pattern to determine if the print head nozzles need cleaning or not at this point.

It's a good idea to run a nozzle check and clean the print head, if necessary, whenever you load a new media type or print a large job. You can also set the printer to automatically print a nozzle check pattern and/or clean the print head at set intervals. See page 114 for details.

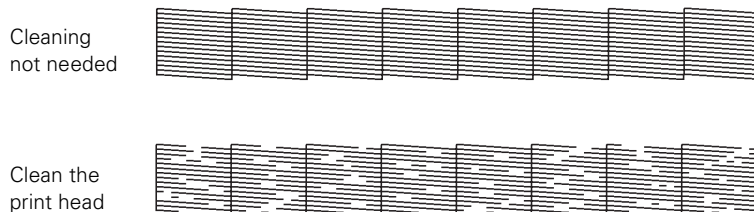

If you need to clean the print head, press and hold the **Menu** button for three seconds. The **Pause** light flashes and **CLEANING** appears on the LCD display.

Cleaning is finished when the **Pause** light stops flashing and **READY** appears on the LCD display.

Adjusting the Print Head Height

Note: Raising the print head height may affect your print quality, so run a test print before printing any large jobs.

If you loaded thick media, or notice any smearing on sharply curled media or after printing at a high speed, the print head may be rubbing against the media. To avoid this, you can adjust the print head height (platen gap).

1. Make sure the printer has finished printing.
2. Open the front cover.

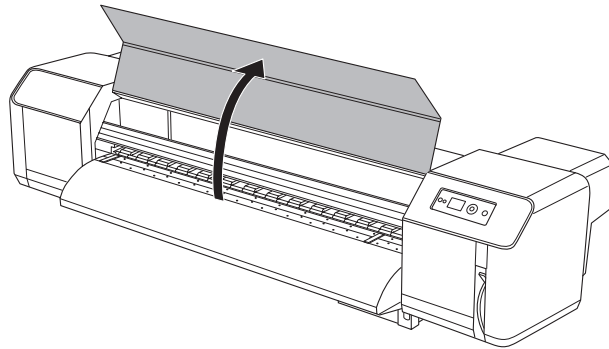

3. To raise the print head, flip the blue head height adjustment lever up to the position shown.

The highest lever position is directly horizontal and the normal position is not quite vertical. Do not place the lever in any other position.

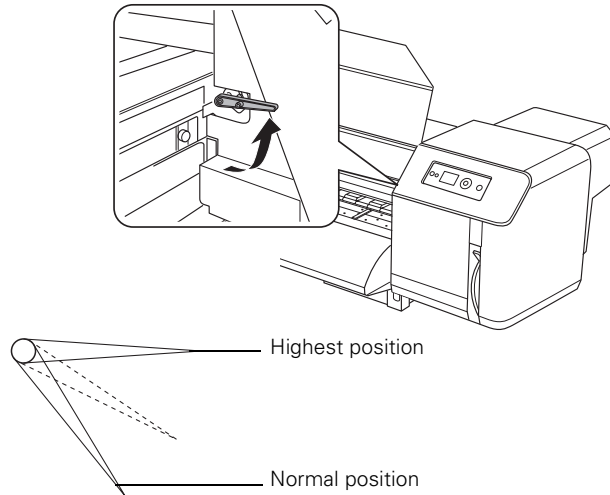

4. When you finish printing on the affected media, return the head height adjustment lever to the normal position.

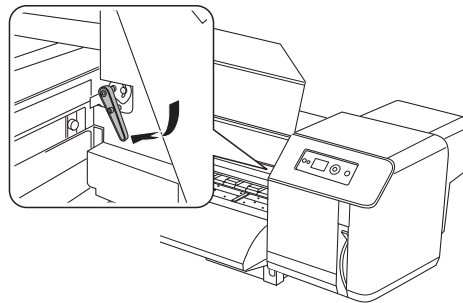

5. Close the front cover.

Setting Up Paper Configurations

Before printing on your loaded media, create a paper configuration (a group of print settings) for the media type. Create a configuration for each media type you use (up to 30 types) and select the desired configuration whenever you print on that media. This ensures that the printer uses optimum print quality settings on all your custom media.

Use the checklist on page 58 whenever you print on a new media type to configure the printer for printing on that media.

Creating Paper Configurations

To create a paper configuration, make sure the media you want to configure is loaded in the printer. Then follow these steps:

1. Press the **Menu** button.
2. Press the ▼ button until **PAPER SETUP** is highlighted, then press **Menu**.
3. Press ▼ to highlight **PAPER SETUP** again, then press **Menu** again.
4. Press ▼ to select the paper configuration number (1 to 30) that you want to use for this media type. Then press **Menu**.
5. Select the following settings for your media based on the information supplied in the media package (see page 117 for details):
 - **PRINT MODE**
 - **PRE HEATER**
 - **PLATEN HEATER**
 - **POST HEATER**
 - **M/W ADJUSTMENT (MicroWeave®)**
 - **PAPER SUCTION**
 - **DRYING TIME**
 - **CARRIAGE MOVEMENT**
 - **PRINT MULTIPLE LAYER**

Tip: Make a note of the paper configuration number you use for each type of media on the back on the *Quick Reference Guide* that came with the printer. Keep the booklet handy by mounting it on the side of the printer using the hook that came with it.

6. Perform the following adjustments to fine-tune printing for your media:
 - PAPER FEED ADJUST (see page 59 for instructions)
 - HEAD ALIGNMENT (see page 61 for instructions)
7. When done, press the **||** Pause button.

After creating your paper configurations, you can print out a list of them.

Printing a List of Your Paper Configurations

You can print a list showing the settings for all your paper configurations. This makes it easy to select the paper configuration number you want.

1. Press the **Menu** button.
2. Press the **▼** button to highlight TEST PRINT, then press **Menu**.
3. Press **▼** until CUSTOM PAPER is highlighted, then press **Menu**.
4. Press **↵** to print your paper configurations.

Printing Using a Paper Configuration

Once you have created a paper configuration, you can select it whenever you print on that media:

1. Press the **Menu** button.
2. Press the **▼** button to highlight PAPER SETUP, then press **Menu**.
3. Press the **▼** button to highlight PAPER TYPE, then press **Menu**.
4. Press **▲** or **▼** to select the paper configuration number you want to use.
5. Press **↵**. The configuration number you selected appears on the LCD display with an asterisk.
6. Press the **||** Pause button to exit the menu. The configuration number appears on the LCD display.
7. Send your print job.

Pre-Printing Checklist

Whenever you print on a new media type, follow these guidelines to configure the media for printing:

- Check the media packaging for print requirements, such as heating temperatures.
- Select a paper configuration number (1 to 30) for the media in the printer's menu system.
- Select these settings for the paper configuration using the information supplied with your media:
 - PRINT MODE
 - PRE HEATER
 - PLATEN HEATER
 - POST HEATER
 - M/W ADJUSTMENT (MicroWeave®)
 - PAPER SUCTION
 - DRYING TIME
 - CARRIAGE MOVEMENT
 - PRINT MULTIPLE LAYER
- Print a nozzle check pattern and clean the print heads, if necessary.
- Perform a 500 mm Line Feed Adjustment to fine-tune the paper feeding position.
- Print a sample pattern and select the best setting to further refine the paper feeding position.
- Print a bidirectional alignment pattern and select the best setting to align the print heads.
- Select the paper configuration number using the printer's menu system and print.

Make a note of the media type and number on the back of the *Quick Reference Guide* and hang the guide on the printer using the supplied hook for easy reference.

Adjusting the Paper Feeding Position

If you notice any overlap or white lines in your printed images, you should adjust the paper feeding position to correct it. You may need to adjust the feeding position differently for different types of media.

Before adjusting the feeding position, make sure you select the following control panel settings for your media type:

- Paper Type
- Print Mode
- M/W Adjustment

See page 117 for details on selecting these settings on the PAPER SETUP menu. Then follow these steps to adjust the paper feeding position on the same menu:

1. Press ▲ or ▼ to select PAPER FEED ADJUST, then press Menu.
2. Press ▲ or ▼ to select LINE FEED ADJUST, then press Menu.
3. Press ▲ or ▼ to set the feed length to 100mm, 250mm, or 500mm (recommended), then press Menu.
4. Press ↵ to print an initial adjustment pattern like this:

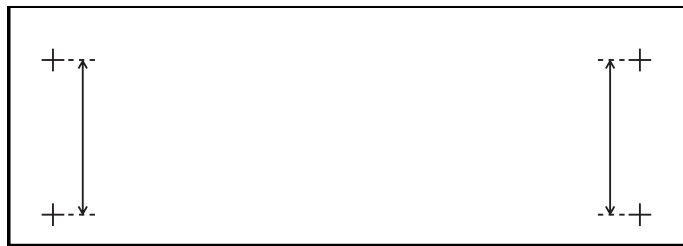

5. Cut off the printed pattern to you can more easily measure it. See page 62 for instructions.
6. Using a ruler with measurements in millimeters, measure the distance between the two + (plus) signs.

7. Press ▲ or ▼ to select the distance you measured, then press the ↵ button.
8. Press ▲ to return to the Paper Feed Adjust menu.
9. Press ▲ or ▼ to select PRINT SAMPLE PATTERN, then press Menu.
10. Press the ↵ button to print sample patterns like the ones to the right:
11. Cut off the printed patterns so you can more easily examine them. See page 62 for instructions.
12. Examine the sets of patterns to identify which one has the most consistent printing pattern, with no black or white lines running through it.

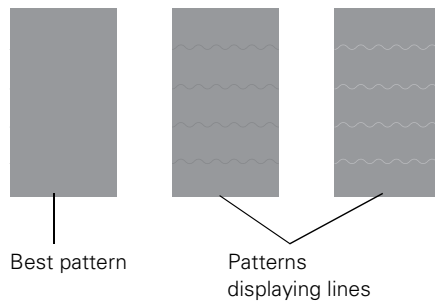
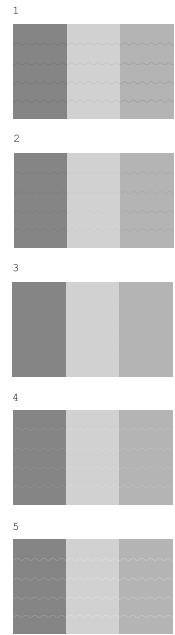

13. Press ▲ or ▼ to select the number of the best pattern, then press the ↵ button to save the setting.
14. Press the || Pause button to exit the menu.

If you were not able to print a sample pattern completely without lines running through it, set the paper lever to the **High Secured** position, then try printing on the media again. See page 48 for details.

Aligning the Print Head

Aligning the print head is the most important thing you can do to ensure the best print quality. If banding appears on your prints, if they look grainy or blurry, or if you see misregistration or “ghosting,” you need to align the print head for each print mode you use.

Note: You can also align the print head using the EPSON LFP Remote Panel utility. Select **Media Adjustment**, then select **Bidirectional Alignment** and follow the on-screen instructions

If you haven't already done so, it's a good idea to run a nozzle check before aligning the print head (see page 53). This ensures that the print head alignment patterns print correctly.

Also check that the head height adjustment lever is in the correct position. See page 54 for details.

1. Make sure the printer is turned on and media is loaded.
2. Press the **Menu** button.
3. Press the **▼** button to highlight **PAPER SETUP**, then press **Menu**.
4. Press the **▼** button to highlight **PAPER TYPE**, then press **Menu**.
5. Press **▲** or **▼** to select the paper configuration number for the loaded media.
6. Press **↵**. The configuration number you selected appears on the LCD display with an asterisk.
7. **HEAD ALIGNMENT** is highlighted. Press **Menu**.
8. **BI-D ALL** is highlighted. Press **↵** to print the alignment patterns.

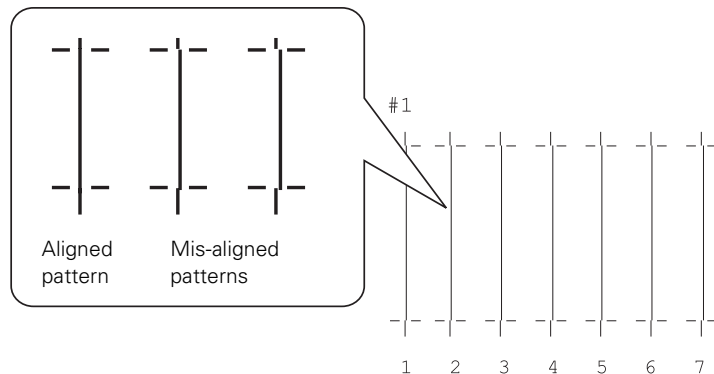

9. Examine the patterns and determine which number in each set has the smallest gaps in the lines. Press the ▲ or ▼ button to select the number for the first set, then press ↵.
10. Repeat step 9 for the rest of the pattern sets.
11. When you are finished, press the ⏸ Pause button to exit.

Cutting Off Prints

When you finish printing and need to remove your printouts, follow the steps below to cut off the prints.

1. Make sure **READY** appears on the LCD display.
2. Press ▲ or ▼ to adjust the cutting position of the media, if necessary. (When you are using the Auto Take-Up Reel, you cannot feed the media backward.)
3. Open the front cover.

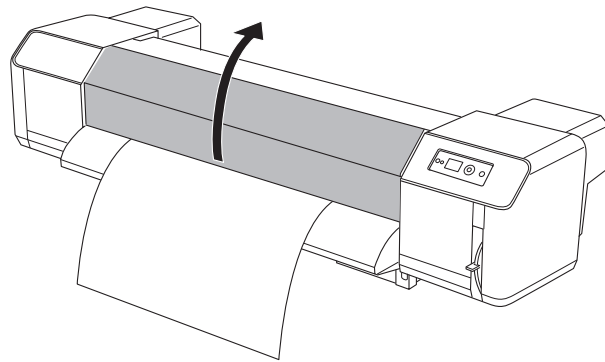

4. If you are not using the Auto Take-Up Reel, hold your print and pull slightly to remove any slack.

WARNING: Do not place your fingers in the path of the cutting tool to avoid injuring yourself.

5. Using a razor blade or other cutting tool, cut off your print by guiding the tool along the cutting groove in the post heater as shown.

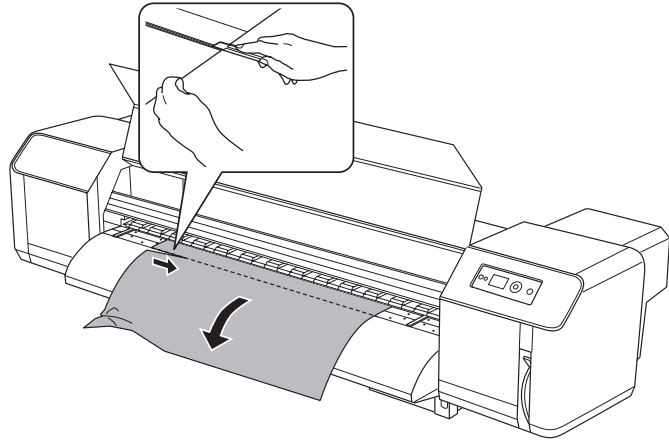

6. If you are using the Auto Take-Up Reel, the scroller rotates to take up your printed media. To stop media take-up, set the switch on the top of the reel controller to **OFF**.

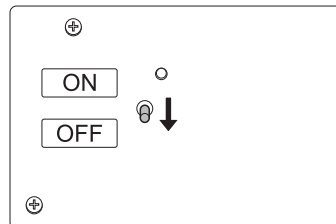

Removing Prints From the Auto Take-Up Reel

After cutting off your prints as described in the previous section, you can remove the roll media from the Auto Take-Up Reel.

1. Make sure the reel controller is set to **OFF**.
2. Flip the scroller release lever up to the **FREE** position.

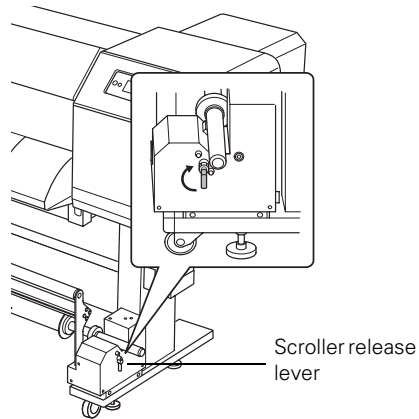

3. Lift the entire scroller bar off of the printer.
4. Remove the paper holders from one end of the scroller bar.
5. Remove the media and core from the scroller bar.
6. Place another empty take-up core onto the scroller bar. You can use a core from an expended media roll or a new core.

7. Place the right end of the scroller bar (the end with the metal collar) down between the rollers in the right controller. Then place the other end between the white rollers on the left mounting bracket. Make sure the scroller bar rests between the rollers at each end.

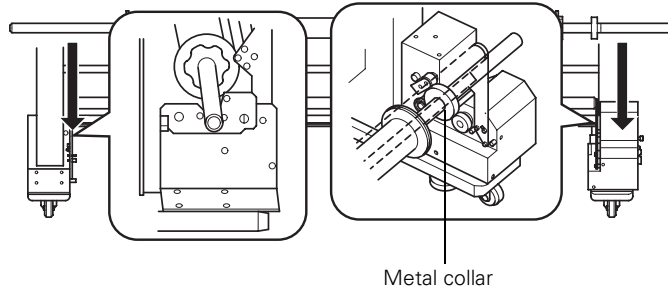

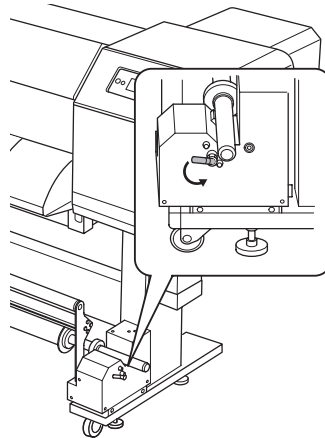

8. Flip down the scroller release lever to the **SET** position.



Replacing Roll Media

When you run out of media or need to change the type of media you are using, follow these steps:

1. Make sure the  Power light is not flashing, then release the paper lever. LEVER RELEASED appears on the LCD display.

Caution: Do not release the paper lever while the  Power light is flashing, or you may damage the printer.

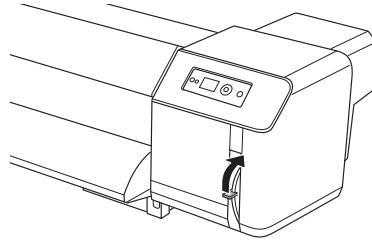

2. Turn the roll backward using the roll paper holders and remove any remaining media from the feed slot.

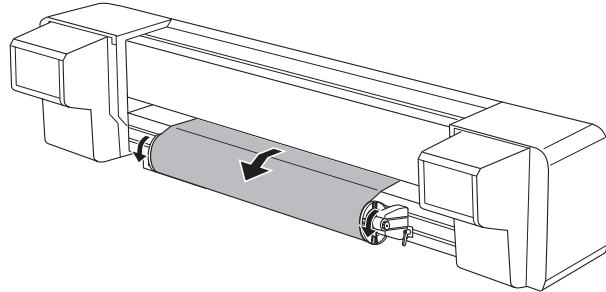

3. Release the right roll paper lever and slide the holder off the end of the roll.

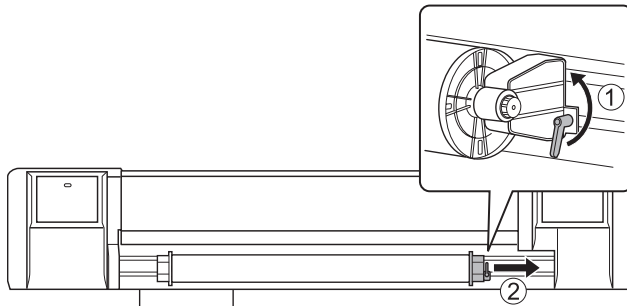

4. If necessary, release the left roll paper lever and remove the holder from the other end of the roll.

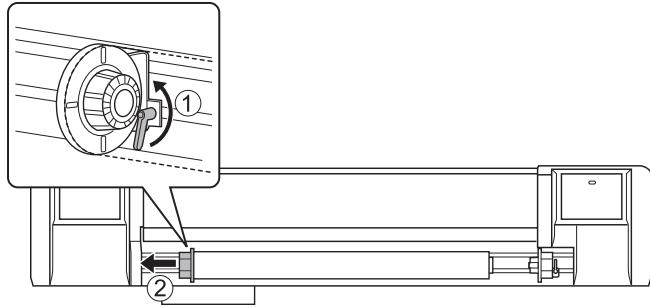

5. Place a new roll on the printer as necessary. See page 43 for instructions.

Chapter 3: Maintaining the Printer

The Epson Stylus Pro GS6000 requires regular maintenance to keep it working at its best. Regular maintenance also reduces the amount of ink required for cleaning cycles and reduces printer “downtime”.

You need check the ink, printer, and waste ink status, and may need to perform adjustment procedures to maintain or correct print quality, as described in this chapter:

- Checking the ink status
- Checking the printer status
- Checking the print head nozzles
- Cleaning the print head
- Replacing ink cartridges
- Disposing of waste ink









If these procedures do not completely solve your print quality problems, you may periodically need to perform the following ink system maintenance procedures:

- Cleaning the cleaning wiper, capping assemblies, and print head casing
- Replacing the ink flushing pad
- Cleaning the print head casing
- Washing the ink system

Checking the Ink Status

Before you begin a large print job, you should check your ink levels. If a cartridge is low, it is best to replace it before starting a large print job. However, if ink is expended after printing for a few minutes, you can replace the necessary cartridges (“hot swap” them) and continue printing.

The easiest way to check ink levels is from the control panel LCD display. The numbers below the ink icons on the LCD display correspond to the ink cartridge slots on the printer. The icons indicate the ink remaining as follows:

Icon	Description
 or 	Plenty of ink is available
 or  or 	Ink is getting low; make sure you have a new cartridge
Flashing 	Ink is low (example shows the yellow cartridge)
	Ink is expended (example shows the yellow cartridge)
	Cartridge error or no cartridge

When the **Check**  ink light is flashing and **INK LOW** appears on the LCD display, the indicated cartridge is almost expended. Make sure you have a replacement cartridge.

When the **Check**  ink light stays on and **REPLACE INK CARTRIDGE** is displayed, the cartridge is expended. You must replace the cartridge before you can continue printing. See page 75 for instructions.

You can also view or print detailed information on ink levels, as described below.

Checking the Printer Status

Using the control panel, you can check the status of the following:

- Printer firmware version number
- Printable pages estimate for the remaining ink
- Level of ink in each cartridge
- Ink and media consumption calculated by the usage counter

- Print job history information
- Total number of pages printed
- Status of the EDM feature

You can print out a status sheet (described in the next section) or view the printer's status on the LCD display (see page 71).

Printing Status Information

In addition to the information listed above, the status sheet lists the current printer and network settings.

1. Make sure media is loaded in the printer.
2. Press the **Menu** button.
3. Press the ▼ button to highlight **TEST PRINT**, then press **Menu**.
4. Press ▼ to highlight **STATUS SHEET**, then press **Menu**. You see **PRINT**.
5. Press ↵ to start printing.

The level of ink left in the cartridges is indicated as follows on the status sheet:

E[*****]F = 100–81% of ink capacity remaining
 E[****]F = 80–61%
 E[***]F = 60–41%
 E[**]F = 40–21%
 E[*]F = 20–11%
 % = less than 10% of ink capacity remaining

Viewing Status Information

1. Press the **Menu** button.
2. Press the ▼ button until **PRINTER STATUS** is highlighted, then press **Menu**.

3. Do one of the following:

- To check the firmware version, press **Menu** again. When done, press the ◀ button.
- To check the number of pages that can be printed with each ink cartridge, press ▼ to highlight **PRINTABLE PAGES**, then press **Menu**. Press ▼ to view the number of pages remaining for each cartridge. When done, press ◀.

(This option must be enabled using maintenance mode on the printer's control panel to display information. See page 120 for instructions.)

- To check the amount of ink left, press ▼ to highlight **INK LEVEL**, then press **Menu**. The status of the first cartridge is displayed. Continue pressing ▼ to see the status of the remaining cartridges. When done, press ◀.
- To check the total amount of ink used (in milliliters) and media used, press ▼ to highlight **USAGE COUNT**, then press **Menu**. When done, press ◀.

You can clear this setting with the **CLEAR USAGE COUNT** option.

- To check the job history, press ▼ to highlight **JOB HISTORY**, then press **Menu**. For the last 10 print jobs saved in the printer, you see the ink used (in milliliters) and media used (in square centimeters). The most recent job is saved as No. 0. When done, press ◀.
- To check the total number of prints, press ▼ to highlight **TOTAL PRINTS**, then press **Menu**. When done, press ◀.
- To check the status of the EDM feature and when it was last uploaded, press ▼ to highlight **EDM STATUS**, then press **Menu**. (See www.mypsonprinter.com for more information.) When done, press ◀.

4. Press the ■■ Pause button to exit the menu.

Note: You can change the units of measurement from centimeters to inches and feet using maintenance mode on the printer's control panel. See page 120 for instructions.

Checking the Print Head Nozzles

If your printed image shows a color shift or horizontal lines, you should check the print head to see if any nozzles are clogged or deflected. If necessary, you can run a cleaning cycle to clear the nozzles or set the printer to automatically clean the nozzles at regular intervals.

You can also set the printer to automatically check the nozzles periodically or before each print job so you can always tell if the print head is clean or not. Select one of the **PRINT NOZZLE PATTERN** options on the **PRINTER SETUP** menu (see page 114 for instructions).

Follow these steps to manually print a nozzle check pattern:

1. Press the **Menu** button.
2. Press the ▼ button until **TEST PRINT** is highlighted, then press **Menu**. **NOZZLE CHECK** is selected.
3. Press **Menu**, then press ↩ to start printing the nozzle check pattern.
Two patterns are printed; one for each print head.
4. After the patterns print, use at least a 10× eye loupe to examine them.
 - If the patterns look good, as shown below, the print head is clean.

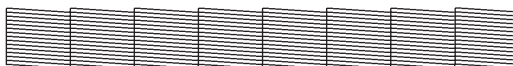

- If any dots or segments are missing or deflected, as shown below, run a cleaning cycle by pressing and holding the **Menu** button for at least three seconds. Then print another nozzle check pattern to make sure the nozzles are clean.

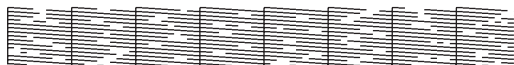

Note: The nozzle check sheet also shows the printer's firmware version and information about its ink and media use.

Note: It is best to clean the print head if you have not used the printer for at least one week to maintain print quality.

Cleaning the Print Head

If you notice gaps, lines, or color shifts in your printouts, or a nozzle check reveals clogged or deflected nozzles, you should clean the print head. You can run print head cleaning cycles in four different levels:

- Very light
- Light (standard level)
- Medium
- Heavy

If you find that you regularly need to clean the print head, you can set up a **REGULAR CLEANING** cycle in the **PRINTER SETUP** menu. This lets you clean the print head a specific number of hours after running a print job to maintain print quality. See page 114 for instructions.

1. Turn on the printer and make sure the **Check** \triangle ink light on the printer's LCD display is not on or flashing.
2. Do one of the following:
 - To run a standard (light) cleaning cycle, press and hold down the **Menu** button for three seconds. Go to step 7.
 - To run another level of cleaning cycle, go to step 3.
3. Press the **Menu** button.
4. Press the \blacktriangledown button until **MAINTENANCE** is highlighted, then press **Menu**.
5. Press \blacktriangledown until one of the following cleaning levels is highlighted, then press **Menu**.
 - **CLEANING (VERY LIGHT)**
 - **CLEANING (LIGHT)**
 - **CLEANING (MEDIUM)**
 - **CLEANING (HEAVY)**
6. Press \blackleftarrow to start the cleaning cycle.

Note: It is best to run a higher level cleaning cycle only when the previous level does not clear the clogged or deflected nozzles.

7. When cleaning is finished and the  Power light stops flashing, print a nozzle check pattern to confirm that the print head is clean (see page 73).

For effective cleaning, always run a nozzle check between cycles.

If the pattern is still missing segments or has deflections after cleaning, clean the print head again using a higher level cleaning cycle.

If the highest level of cleaning cycle still does not unclog the nozzles, you can wash the ink system. See page 86 for instructions.

Note: You must use at least a 10x eye loupe to examine the nozzle check pattern for deflected nozzles.

Note: We recommend that you use genuine Epson cartridges and do not refill them. The use of other products may affect your print quality and could result in printer damage.

Yields vary considerably based on images printed, print settings, paper type, frequency of use, and temperature. For print quality, a small amount of ink remains in the cartridge after the “replace cartridge” indicator comes on.

For best printing results, use up a cartridge within six months of opening the package.

Replacing Ink Cartridges

When you need to replace an ink cartridge, use the following Epson UltraChrome® GS ink cartridges:

Slot no.	Cartridge	Part number
1	Orange	T624800
2	Green	T624700
3	Light Magenta	T624600
4	Light Cyan	T624500
5	Black	T624100
6	Yellow	T624400
7	Magenta	T624300
8	Cyan	T624200

You can purchase genuine Epson ink and paper from an Epson Professional Imaging Authorized Reseller. To find the nearest reseller, visit www.proimaging.epson.com (U.S. sales), www.epson.ca (Canadian sales), or call 800-GO-EPSON (800-463-7766). Or you can purchase online at www.proimaging.epson.com (U.S. sales) or www.epson.ca (Canadian sales).

1. Before replacing ink cartridges, make sure the printer is turned on.
2. Note the color of the cartridge that is low or expended so you know where to replace the cartridge.

Caution: Leave the expended cartridge in the printer until you are ready to replace it.

To prevent ink reporting errors, never replace the ink cartridges with the printer turned off.

#8 #7 #6 #5 #4 #3 #2 #1
Cyan, Magenta, Yellow, Black Light Cyan, Light Magenta, Green, Orange

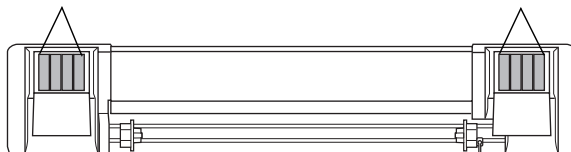

3. Press the ink compartment cover to open it.

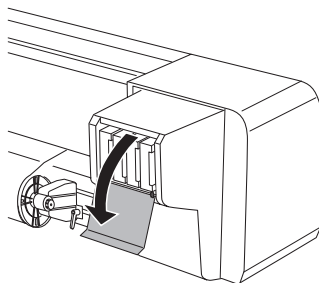

WARNING: Do not shake the expended cartridge, or ink may leak out. If ink gets on your hands, wash them thoroughly with soap and water. If ink gets in your eyes, flush them immediately with water.

4. Remove the low or expended ink cartridge from the printer.

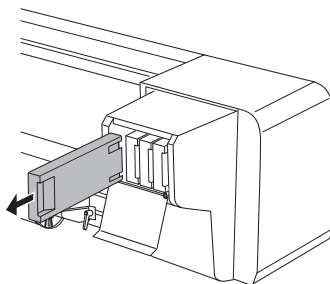

5. Vigorously shake the new ink cartridge in its package for about five seconds, then remove it from its package.

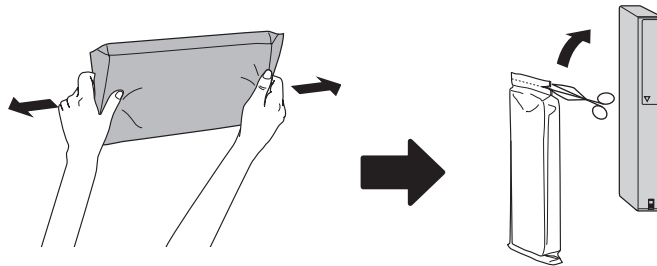

Note: If you can't insert the cartridge smoothly, you may have the wrong cartridge. Check the package and product code. If the **Check** Δ ink light remains on after installing the cartridge, it may not be inserted fully.

6. Hold the cartridge with the arrow pointing toward the printer. Then insert the cartridge into the slot. Don't force it in.

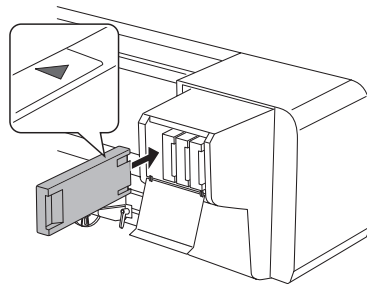

Caution: Do not remove and re-insert cartridges more often than necessary. Doing so can compromise the needle valve seal and allow air to enter the ink tubes, causing nozzle damage.

7. Close the ink compartment cover.

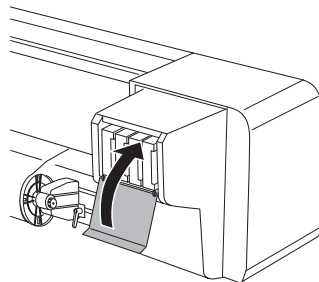

The printer returns to its **READY** state.

WARNING: Before handling the waste ink, read the Material Safety Data Sheet (MSDS) for your printer. You can download it from Epson's support website at epson.com/support (U.S.) or epson.ca/support (Canada).

The waste ink from the printer is industrial waste. Proper waste ink disposal in compliance with the industrial waste disposal laws and ordinances of your local government is required. Consign disposal of waste inks to an industrial waste disposer. Please provide the Waste Ink Data Sheet to the industrial waste disposer. You can download it from Epson's support website at epson.com/support (U.S.) or epson.ca/support (Canada).

Disposing of Waste Ink

Periodically, you need to dispose of waste ink that collects in the waste ink tank beneath the printer. You should dispose of the waste ink when:

- The waste ink tank is more than half full
- The **DRAIN TANK FULL** message appears on the LCD display

Before you dispose of waste ink, gather the following supplies:

- An empty 2 liter polypropylene or high-density polyethylene bottle with a cap to hold the drained waste ink (one bottle was included with your printer, and you can order additional bottles from Epson; see page 10)
 - A cloth for wiping the waste ink tank spigot
1. Hold the empty container beneath the spigot on the printer's waste ink tank, then turn the valve as shown to drain the waste ink. Keep the container close to the spigot to avoid splashing the waste ink.

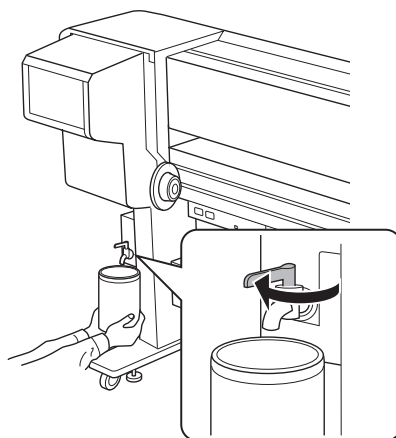

- When all the waste ink has drained, close the valve on the spigot.

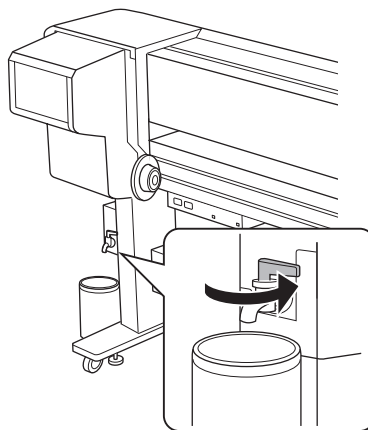

- Wipe the mouth of the spigot on the waste ink tank with a cloth.
- Dispose of the waste ink and the cloth in compliance with industrial waste disposal laws and local government ordinances as required in your area. See the warning on page 78 for details.

Cleaning the Cleaning Wiper, Capping Assemblies, and Print Head Casings

Caution: You must complete the process of cleaning the cleaning wiper, capping assemblies, and print head casing within 15 minutes to prevent the print head from drying out.

Depending on your print volume, you should to clean the print head cleaning wiper, capping assemblies, and print head casings once a month. You may also need to clean them if you notice blurred ink or gaps in your printouts after cleaning the print head.

You will need the plastic gloves and a cleaning swabs that came in the Maintenance Kit and the metal tray included with your printer to clean the cleaning wiper, capping assemblies, and print head casings.



Plastic gloves

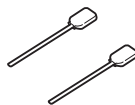

Cleaning swabs

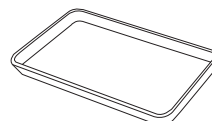

Metal tray

Note: If you need more swabs, purchase an Additional Printer Maintenance Kit (1 year supply). See page 10 for ordering information.

Place your used gloves and swabs in the metal tray when you are finished to avoid getting ink on any of the printer parts; this may damage the plastic.

1. Turn on the printer.
2. Press the **Menu** button.
3. Press the ▼ button to highlight **MAINTENANCE**, then press **Menu**.
4. Press ▼ to highlight **CARRIAGE MAINTENANCE**, then press **Menu**.
5. Press ↵.

The print head moves to the left, the cleaning wiper moves forward, and **OPEN MAINT COVERS** appears on the LCD display.

6. To clean the cleaning wiper and capping assemblies, push in the top of the maintenance cover beneath the control panel, then release it to open the cover.

Caution: Do not place any supplies on the open maintenance cover or it may fall off.

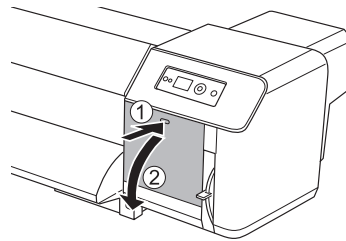

7. Put on a plastic glove, then use a cleaning swab to clean ink and dust from both sides of the cleaning wiper as shown. Wipe back and forth on the outside surface, and up and down on the inside surface.

Also clean excess ink from the top of the capping assemblies and their rubber surrounds.

When you are finished, go to step 12.

If the cleaning wiper and capping assemblies are still not clean, go to step 8.

Caution: Do not touch the cleaning wiper or any other internal part with your hands to prevent oil from your skin interfering with head cleaning operations.

Do not moisten the cleaning swab with water or it may damage the print head.

Do not let the cleaning swab touch any other part of the printer or it may stain it with ink.

Do not reuse a cleaning swab; dirt or ink from the swab may damage the print head.

Clean the top and rubber surrounds of both capping assemblies

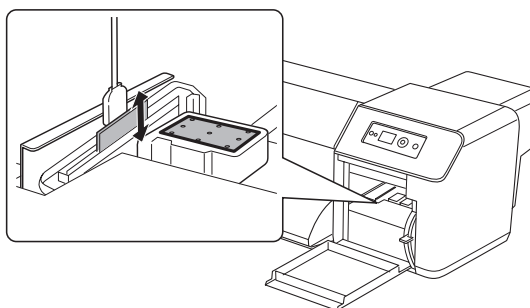
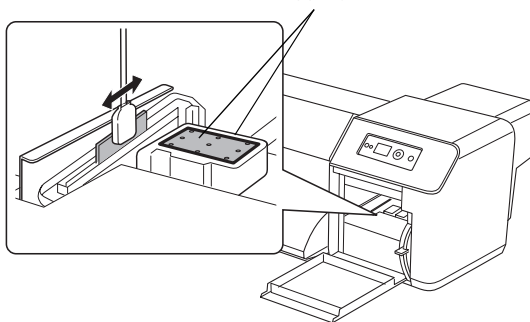

8. **If ink has hardened on the cleaning wiper and/or capping assemblies, and cannot be removed with a dry cleaning swab, you need to clean them using the optional Print Head Cleaning Kit, which includes special cleaning fluid and a cup.**

When ordering the Print Head Cleaning Kit, ask for part number C12C890621. See page 10 for ordering information.

WARNING: Before handling the ink cleaner, read the Material Safety Data Sheet (MSDS) for your printer. You can download it from Epson's support website at epson.com/support (U.S.) or epson.ca/support (Canada).

Make sure your workspace is well ventilated and free of any open flame before opening the ink cleaner.

Keep ink cleaner out of the reach of children.

Do not let ink cleaner contact your skin, eyes, or clothing. If it gets on your skin or in your eyes, wash them well with water.

Avoid ingesting the cleaner or inhaling its vapors. If you accidentally swallow any ink cleaner, do not vomit. Consult a doctor as soon as possible.

Use ink cleaner only for cleaning the cleaning wiper or the print head casing. It may damage other parts of your printer.

- Put on a plastic glove and pour ink cleaner into the plastic cup up to the 10 ml line.

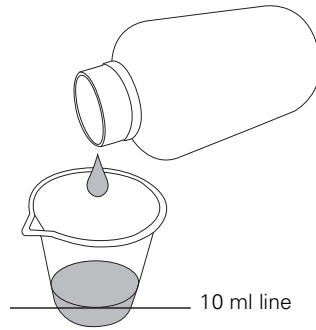

- Dampen a new cleaning swab with ink cleaner, being careful not to let it drip.
- Repeat step 7 to clean the cleaning wiper and capping assemblies.
- Close the maintenance cover and press it until it locks in place.

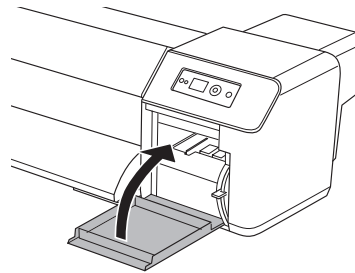

- To clean the print head casings, open the left maintenance cover, then lift the cover off of the printer to remove it; this makes it easier to clean the print head casings.

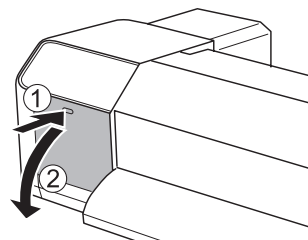

Caution: Do not touch the print head or the tip of the swab with your hands to prevent oil on your skin from damaging the print head.

Do not moisten the cleaning swab with water or it may damage the print head.

Do not let the cleaning swab touch any other part of the printer or it may stain it with ink.

Do not reuse a cleaning swab; dirt or ink from the swab may damage the print head.

14. Use a flashlight and the reflective base of the maintenance bay to check if there is any dust or ink on the casings surrounding the print heads. You can clean the areas on the underside of the print heads, shown in gray below.

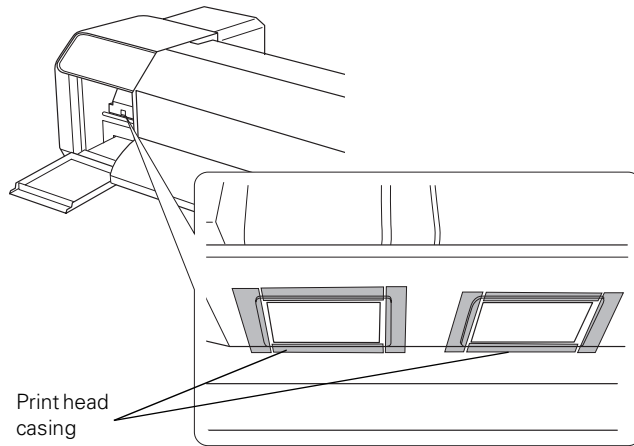

15. Put on a plastic glove, then use a cleaning swab to clean around the print head casings as shown. (You may want to place the metal tray in the maintenance bay to catch any ink that may fall off.) Wipe back and forth, and up and down around the print head casings.

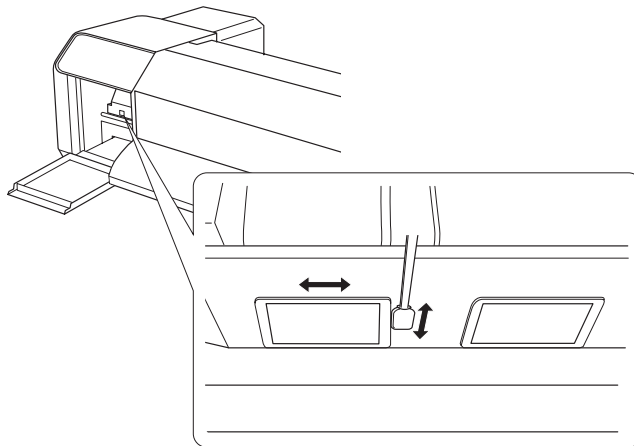

16. If ink has hardened on the print head casings and cannot be removed with a dry cleaning swab, you need to clean them using the optional Print Head Cleaning Kit. Follow step 9 and step 10 to moisten the cleaning swab, then clean the print head casings again, as described in step 15.
17. Dispose of the used ink cleaner, swabs, and gloves in compliance with industrial waste disposal laws and local government ordinances as required in your area.
18. Replace the maintenance cover, close it, and press it until it locks in place.

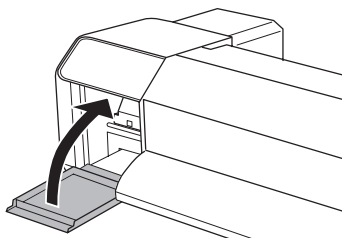

19. Press the **||** Pause button to return the printer to the **READY** state.

Replacing the Flushing Pad

Once a year, you need to replace the printer's flushing pad. You may also need to replace it if you notice ink smears on your media or if the pad becomes damaged or excessively soiled.

You will need the replacement flushing pad and plastic gloves that came in the Maintenance Kit and the metal tray included with your printer.

Note: If you need more flushing pads, purchase an Additional Printer Maintenance Kit (1 year supply). See page 10 for ordering information.



Plastic gloves



Flushing pad

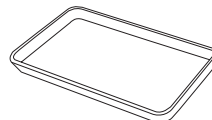

Metal tray

Place your used gloves and flushing pad in the metal tray when you are finished to avoid getting ink on any of the printer parts; this may damage the plastic.

1. Turn on the printer.
2. Press the **Menu** button.
3. Press the ▼ button to highlight **MAINTENANCE**, then press **Menu**.
4. Press ▼ to highlight **CARRIAGE MAINTENANCE**, then press **Menu**.
5. Press ↵.

The print head moves to the left, the cleaning wiper moves forward, and **OPEN MAINT COVERS** appears on the LCD display.

6. Push in the top of the maintenance cover beneath the control panel, then release it to open the cover.

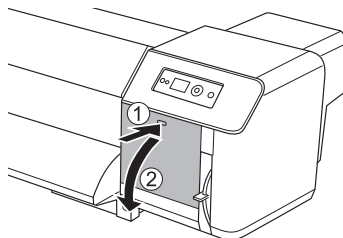

7. Put on a plastic glove and grasp the tab on the used flushing pad to remove it from the left side of the maintenance bay. Place the pad in the metal tray.

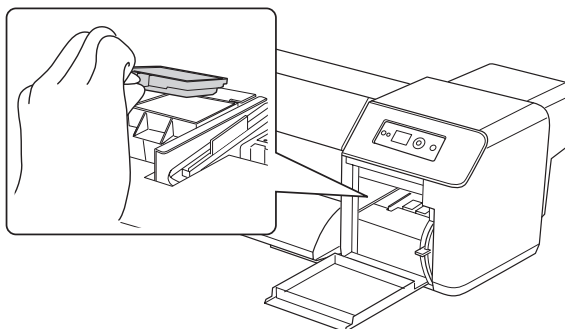

Caution: Do not place any supplies on the open maintenance cover or it may fall off.

Hold the flushing pad upright and level as you remove it to prevent ink from spilling. Be careful not to let ink spill onto any part of the printer.

8. Install the new flushing pad where you removed the old one with the tab facing forward. Press it down until it clicks into place.
9. Close the maintenance cover and press it until it locks in place.

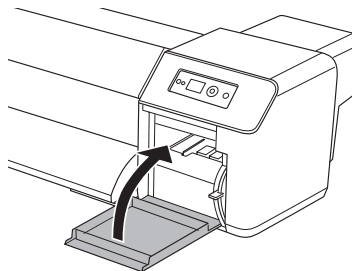

WARNING: Before handling the waste ink, read the Material Safety Data Sheet (MSDS) for your printer. You can download it from Epson's support website at epson.com/support (U.S.) or epson.ca/support (Canada).

The waste ink from the printer is industrial waste. Proper waste ink disposal in compliance with the industrial waste disposal laws and ordinances of your local government is required. Consign disposal of waste inks to an industrial waste disposer. Please provide the Waste Ink Data Sheet to the industrial waste disposer. You can download it from Epson's support website at epson.com/support (U.S.) or epson.ca/support (Canada).

10. Press the **||** Pause button to return the printer to the **READY** state.
11. Dispose of the used flushing pad and gloves in compliance with industrial waste disposal laws and local government ordinances as required in your area.

Washing the Ink System

If you notice gaps, lines, or color shifts in your printouts, and a nozzle check reveals clogged or deflected nozzles, you should clean the print head using the control panel. See page 74 for instructions.

If you still have print quality problems after cleaning the print head using the heaviest level of cleaning cycle, you can wash the ink system to clear the clogged nozzles.

Washing the ink system involves the following procedures:

- Removing the ink cartridges
- Emptying the waste ink tank
- Inserting the cleaning cartridges
- Emptying the waste ink tank again
- Removing the cleaning cartridges
- Emptying the waste ink tank again
- Installing ink cartridges and charging the ink system

Before you wash the ink system, gather the following supplies:

- Empty 2 liter polypropylene or high-density polyethylene bottles with caps to hold the drained waste ink (one bottle was included with your printer, and you can order additional bottles from Epson; see page 10)
- A cloth for wiping the waste ink tank spigot
- A set of Additional Cleaning Cartridges from Epson; see page 10 for ordering information
- A set of new ink cartridges or used cartridges with plenty of ink left in them

Caution: Washing the ink system takes around 33 minutes. Carefully follow all the instructions on the LCD display to avoid errors. If you see a **DRAIN TANK FULL** error, empty the waste ink tank. If you see a **COVER OPEN** error, close the indicated cover.

1. Turn on the printer.
2. Press the **Menu** button.
3. Press the ▼ button to highlight **MAINTENANCE**, then press **Menu**.
4. Press ▼ to highlight **HEAD WASHING**, then press **Menu**.
5. Carefully follow all the instructions as they appear on the LCD display. For detailed instructions see these sections:
 - Removing ink cartridges (see page 75)
 - Emptying the waste ink tank (see page 78)
 - Inserting and removing cleaning cartridges (see page 33)
 - Inserting ink cartridges (see page 35)

Chapter 4: Cleaning, Storing, and Transporting the Printer

The Epson Stylus Pro GS6000 requires periodic cleaning. You may also need to prepare the printer for storage, moving, or transportation.

- Cleaning the printer
- Storing the printer
- Moving or transporting the printer

Cleaning the Printer

To keep your printer working at its best, clean it if it becomes dirty.

1. Remove any loaded media from the printer (see page 66).
2. Turn off the printer and wait for all of its lights to turn off.
3. Unplug the power cord and disconnect the printer from your system.
4. Wait one minute, then open the front cover.

Caution: Be careful not to touch the gears inside the printer.

To avoid damaging the components as well as the case, never use alcohol or thinners to clean the printer.

Be careful not to get water on the printer mechanism or electronic components.

Don't use a hard or abrasive brush.

Don't spray the inside of the printer with lubricants; unsuitable oils can damage the mechanism. Contact Epson if you think the printer needs lubrication.

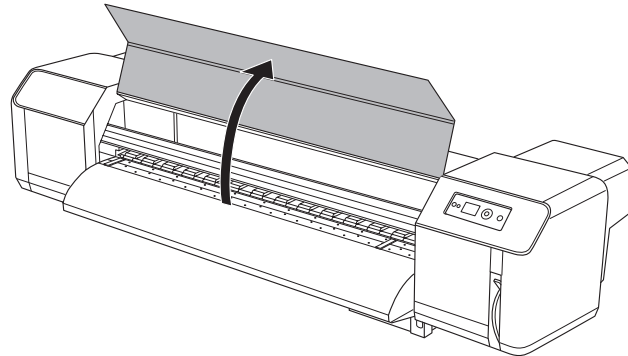

Caution: Do not use tools such as compressed air to clean away dust or dirt. It may blow debris into the printer.

5. Remove any paper dust or dirt from the clear rubber pressure rollers with a soft brush.

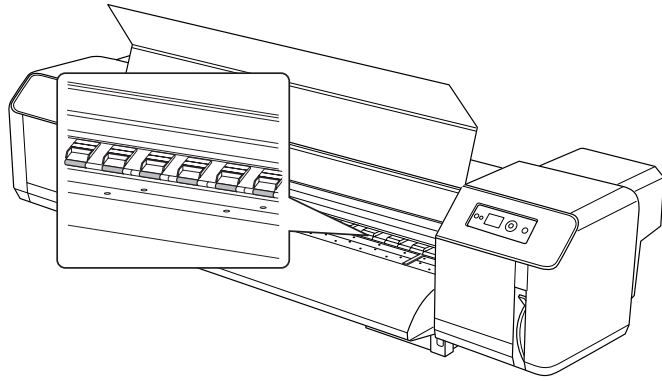

6. Use a slightly dampened soft cloth to clean the platen and the post heater.

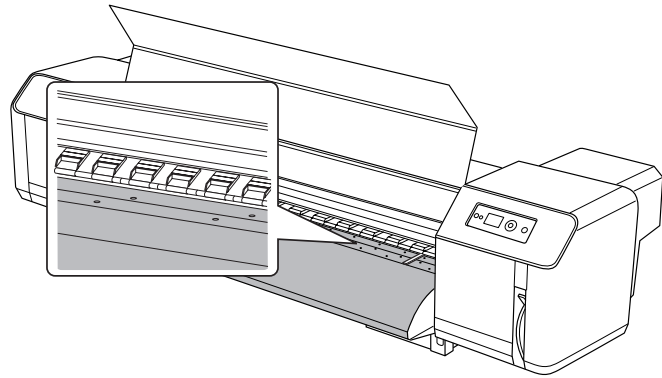

7. If the outer case is dirty, close the front cover and clean the case with a soft, clean cloth dampened with mild detergent. Keep the ink cartridge compartments and maintenance covers closed to prevent water from getting inside.

Storing the Printer

If you will store the printer and not use it for a long time, follow these steps to prepare it for storage:

1. Make sure the printer has stopped printing or performing any maintenance procedures.
2. Open the right maintenance cover and make sure the print head is on the right side (in the capped position).

If it is not capped, turn on the printer, wait a moment, then turn it off and check again. Never move the print head by hand.

3. Remove any media loaded in the printer (see page 66).
4. Dispose of any waste ink in the waste ink tank (see page 78).
5. Press the  Power button to turn off the printer.
6. Disconnect the power cord and any interface cables.
7. Store the printer in a location with a flat level surface.

To maintain print quality during storage, clean the print head once a week (see page 74).

Moving or Transporting the Printer

If you are moving the printer a short distance (for example, in the same building), you can roll it on its stand as described on page 92.

To ship the printer a longer distance, you should carefully follow the instructions on page 93 to prepare the printer for shipment.

Caution: Do not remove the ink cartridges or leave the print head uncapped when storing the printer; otherwise the print head may dry out and be unable to print properly.

Never turn off the printer by disconnecting the power cord or turning off power to the electrical outlet.

Do not tilt the printer, stand it on end, or turn it upside down to store it, or ink will leak and you may damage the printer.

Caution: Do not remove the ink cartridges or leave the print head uncapped when moving the printer; otherwise the print head may dry out and be unable to print properly.

Never turn off the printer by disconnecting the power cord or turning off power to the electrical outlet.

Do not tilt the printer, stand it on end, or turn it upside down when moving it, or ink will leak and you may damage the printer.

Caution: Do not roll the printer on angled or uneven surfaces.

Moving the Printer on the Stand

When you need to move the printer a short distance, such as within the same building, you can roll the printer on its casters.

1. Open the right maintenance cover and make sure the print head is on the right side (in the capped position).

If it is not capped, turn on the printer, wait a moment, then turn it off and check again. Never move the print head by hand.

2. Dispose of any waste ink in the waste ink tank (see page 78).
3. Press the  Power button to turn off the printer.
4. Disconnect the power cord and interface cable.
5. Make sure the front cover is closed.
6. Rotate the feet counter-clockwise to raise them.

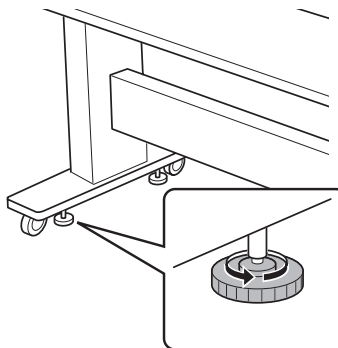

7. Carefully roll the printer to its new location, then rotate the feet clockwise to stabilize the stand.

Preparing the Printer for Shipment

Before shipping the printer, you must carefully prepare it for shipment. How you do this depends on how long the printer will be idle:

- Less than 1 week
- 1 or 2 weeks
- More than 2 weeks

Less than 1 week preparation

1. Open the right maintenance cover and make sure the print head is on the right side (in the capped position).

If it is not capped, turn on the printer, wait a moment, then turn it off and check again. Never move the print head by hand.

2. Press the  Power button to turn off the printer.
3. Dispose of any waste ink in the waste ink tank (see page 78). Then remove the waste ink tank from the printer, cover the end of the waste ink tube with plastic, and secure it with tape to prevent leaks. (Do not remove the ink cartridges from the printer.)
4. Remove the following parts:
 - Power cord and interface cables
 - Loaded media
 - Auto Take-up Reel

Caution: Never turn off the printer by disconnecting the power cord or turning off power to the electrical outlet.

Do not tilt the printer, stand it on end, or turn it upside down when transporting it, or ink will leak and you may damage the printer.

5. Reinstall the bolt and bracket securing the print head that you removed during setup.

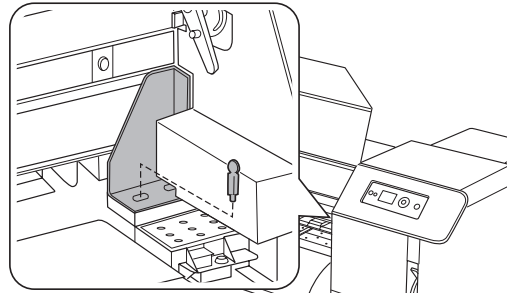

6. Close any open covers on the printer and tape them shut.
7. Follow the steps on page 96 to remove the printer from the stand.

When you set up the printer again, follow the steps in Chapter 1 to attach the printer to the stand, install the Auto Take-Up Reel, remove the print head bracket and bolt, and connect the power and interface cables. The first time you print, it's a good idea to run a cleaning cycle (page 74) and realign the print head (page 61) to ensure good print quality.

Caution: Never turn off the printer by disconnecting the power cord or turning off power to the electrical outlet.

Do not tilt the printer, stand it on end, or turn it upside down when transporting it, or ink will leak and you may damage the printer.

Carefully follow all the instructions on the LCD display to avoid errors. If you see a **DRAIN TANK FULL** error, you failed to empty the waste ink tank when instructed. If you see a **COVER OPEN** error, you opened a cover on the printer when you were not instructed to.

1 to 2 week preparation

You will need a set of additional cleaning cartridges to wash the ink system in these steps; see page 10 for ordering information. This process also uses ink from your ink cartridges to re-initialize the printer.

1. Dispose of any waste ink in the waste ink tank (see page 78).
2. Turn on the printer.
3. Press the **Menu** button.
4. Press the **▼** button to highlight **MAINTENANCE**, then press **Menu**.
5. Press **▼** to highlight **HEAD WASHING**, then press **Menu**.

6. Carefully follow the instructions to drain and wash the ink system as they appear on the LCD display. Follow the instructions to the point where you remove the cleaning cartridges and drain the cleaning fluid. **After draining the cleaning fluid, press the  Power button to turn off the printer. Do not install new ink cartridges.**
7. Dispose of any waste ink in the waste ink tank (see page 78). Then remove the waste ink tank from the printer, cover the end of the waste ink tube with plastic, and secure it with tape to prevent leaks.
8. Remove the following parts:
 - Power cord and interface cables
 - Loaded media
 - Auto Take-up Reel
9. Reinstall the bolt and bracket securing the print head that you removed during setup.

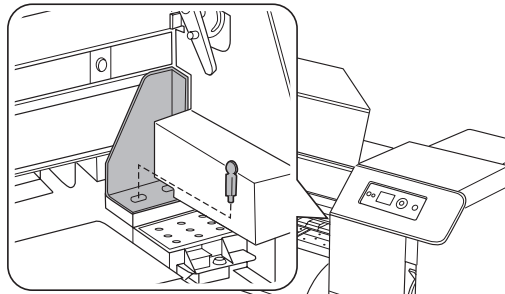

Note: Transport any partially used ink and cleaning cartridges in separate, resealable plastic bags.

10. Close any open covers on the printer and tape them shut.
11. Follow the steps on page 96 to remove the printer from the stand.

When you set up the printer again, follow the steps in Chapter 1 to attach the printer to the stand, install the Auto Take-Up Reel, remove the print head bracket and bolt, connect the power and interface cables, and install new ink cartridges.

The first time you turn on the printer, it will take some time to prime the ink system. It's a good idea to then align the print head (page 61) to ensure good print quality.

More than 2 week preparation

If the printer will be transported and idle for more than 2 weeks, follow the steps above to prepare it for transportation. However, when you set up the printer again, you may need to contact Epson (see page 11) for additional instructions on preparing the ink system for printing using a new set of cartridges.

Removing the printer from the stand

1. Rotate the feet clockwise to stabilize the stand before removing the printer from it.

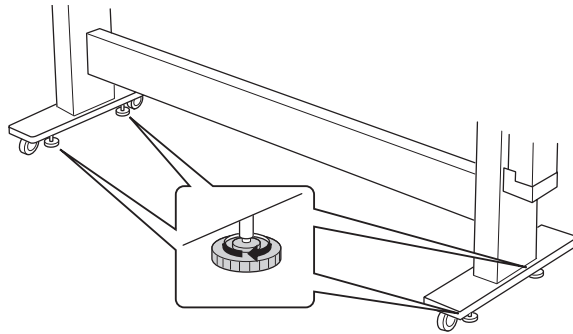

2. Remove the four wing screws securing the printer to the stand. Keep them in a safe place.

Tip: For more secure transportation, tape all doors and covers shut.

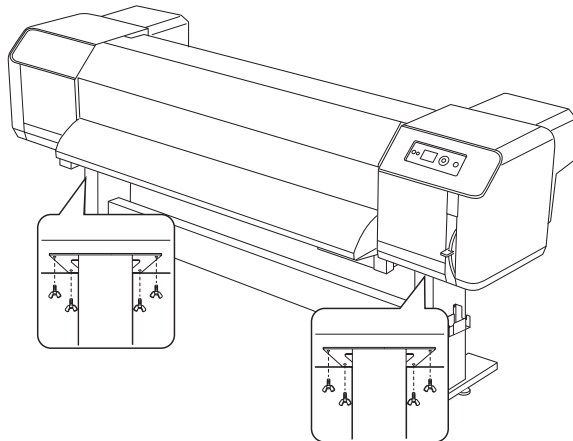

Caution: Do not lift the printer from beneath the black plastic areas in back; lift it from the metal area in the middle.

WARNING: Six or more people are required to lift the printer.

3. Have six people lift the printer off of the stand. If you like, you can lift the printer using two 1-inch × 84-inch steel pipes (available at hardware stores). Insert the pipes into the guides beneath the printer.

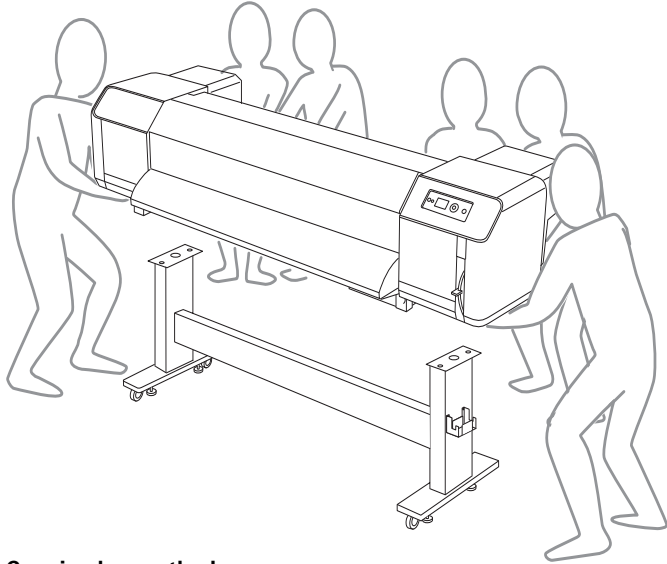

Carrying bar method

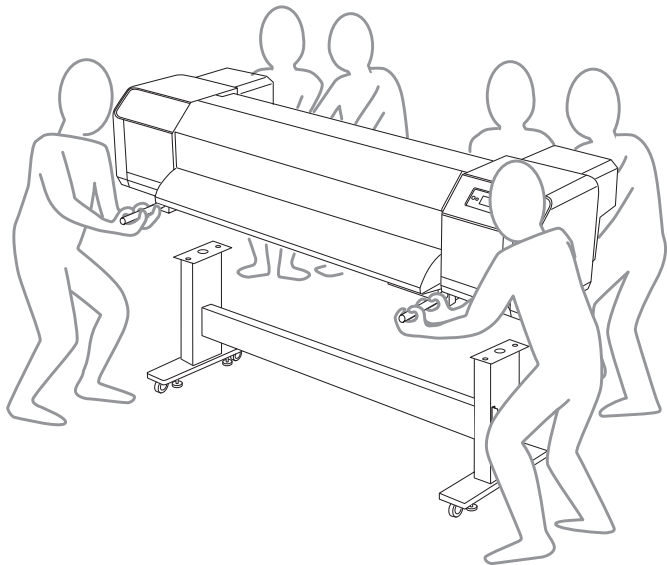

4. Repack the printer using the original box and packing materials, if possible.

Chapter 5: Solving Problems

As you use your printer, you may occasionally experience a problem. You can diagnose the problem following the guidelines in this chapter or check the FAQs at www.proimaging.epson.com. Then try the most likely solutions until the problem is fixed.

This chapter provides instructions for the following:

- Diagnosing problems
- Checking error messages and lights
- Solving operational problems
- Improving print quality
- Solving media problems, including clearing media jams

Diagnosing Problems

The printer includes a number of ways to help you diagnose problems:

- To identify the most common problems, check the messages and lights on the control panel. See the list beginning on page 100 for more information.
- To determine whether the problem is caused by the printer itself, print a status sheet from the control panel. See page 71 for instructions.
- Review the FAQs at www.proimaging.epson.com for possible solutions.
- If none of the suggested solutions in this chapter solve your problem, contact Epson as described under “Where To Get Help” on page 11.

Checking Error Messages and Lights

The control panel includes various lights and an LCD display to indicate the status of the printer:

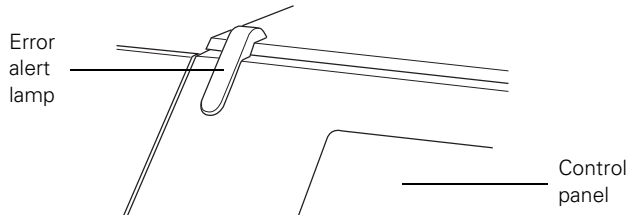
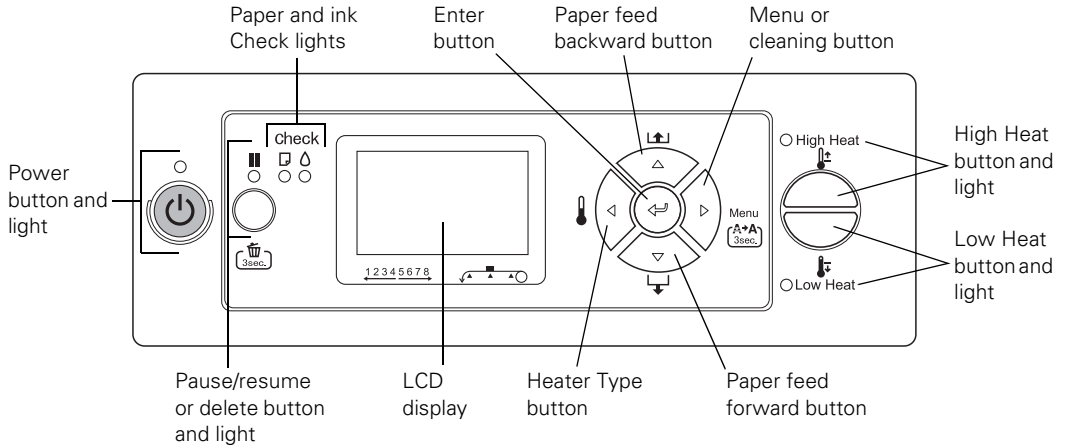



When your media runs out, ink is low, or a problem occurs, a message appears on the LCD display, and the large Error alert lamp and the lights on the control panel come on or flash.

The following table lists the messages in alphabetical order and includes an explanation and instructions for correcting the problem.

Message	Explanation	Response
CARRIAGE LOCKED RELEASE THE CARRIAGE LOCK	The print head is locked.	Remove the bracket securing the print head; see page 27.
COMMAND ERROR CHECK DRIVER SETTINGS	You may be using the wrong printer driver. Damaged data was sent to the printer or the data has an incorrect command.	Press and hold the Pause button for three seconds to cancel the print job. Make sure you installed the correct driver for your printer.
DRAIN TANK FULL DRAIN WASTE INK FROM THE DRAIN TANK	The waste ink tank is full.	Dispose of the waste ink in the waste ink tank. See page 78 for instructions.
FRONT COVER OPEN CLOSE FRONT COVER	Front cover is open.	Close the front cover.
F/W INSTALL ERROR UPDATE FAILED RESTART THE PRINTER	Firmware update failed.	Restart the printer, then update the firmware again; see page 38 for instructions.
INK CARTRIDGE NON-GENUINE CARTRIDGE MAY NOT PERFORM AT OPTIMUM. CONTINUE? <YES NO>	A non-genuine ink cartridge is installed.	Press the ▶ button to select NO and replace the ink cartridge with a genuine Epson ink cartridge; see page 75. Otherwise, press ◀ to select YES .
INK CARTRIDGE PLEASE USE GENUINE EPSON INK CARTRIDGES	A non-genuine ink cartridge is installed.	Replace the ink cartridge with a genuine Epson ink cartridge; see page 75.
INK CARTRIDGE REPLACE INK CARTRIDGE	Ink cartridge(s) are expended (printing stops).	Replace the ink cartridge(s) indicated on the LCD display; see page 75.
INK CARTRIDGE DO YOU ACCEPT THIS? <ACCEPT DECLINE>	A non-Epson ink cartridge is installed.	Press the ▶ button to select DECLINE and replace the ink cartridge with a genuine Epson ink cartridge; see page 75. Pressing ◀ to select ACCEPT may cause damage not covered by your warranty.

Message	Explanation	Response
INK CARTRIDGE ERROR REPLACE CARTRIDGE	There is a problem with the installed cartridge.	Remove the cartridge and make sure there is no condensation on it. Leave the cartridge uninstalled for four hours or more before reinstalling it. If you reinstall the cartridge and still see this error message, install a new cartridge. See page 75 for instructions.
INK COVER OPEN CLOSE RIGHT AND LEFT INK COVERS	The indicated ink covers are open.	Close the indicated ink covers.
INK COVER OPEN CLOSE LEFT INK COVER		
INK COVER OPEN CLOSE RIGHT INK COVER		
INK LOW	Ink cartridge(s) are nearly expended (printing continues).	Make sure you have replacement cartridges available; see page 75. Print quality may decline when ink is low.
LEVER RELEASED LOAD PAPER	Paper is not loaded.	Load paper and set the lever to the Secured position. See page 43 for instructions.
LEVER RELEASED LOWER THE PAPER SET LEVER	Paper lever is released.	Set the paper lever to the Secured position. Start printing again from the beginning for best results.
MAINT COVER OPEN CLOSE RIGHT MAINT COVER	The indicated maintenance cover is open.	Close the indicated maintenance cover.
MAINT COVER OPEN CLOSE LEFT MAINT COVER		
MAINTENANCE REQUEST	A printer part may need to be replaced soon.	Note the code number and contact Epson as described on page 11.
NO CARTRIDGE INSTALL INK CARTRIDGE	Ink cartridge(s) not installed.	Install ink cartridge(s); see page 75. If you just replaced a cartridge when this message appeared, do not reinstall the cartridge that caused the error.



Message	Explanation	Response
PAPER ERROR LOAD PAPER PROPERLY	Printer cannot detect paper.	Make sure the roll is cut evenly. Release the paper lever and reload paper. See page 43 for instructions.
PAPER JAM REMOVE PAPER	Paper has jammed in the printer.	Release the paper lever and remove the jammed paper. Turn the printer off and then back on; see page 107 for more information.
PAPER OUT LOAD PAPER	Paper ran out or has not ejected properly.	Release the paper lever and load paper again. See page 43 for instructions.
PAPER SKEW LOAD PAPER PROPERLY	Paper is not loaded straight.	Release the lever and load the paper correctly. Then return the lever to the Secured position.
PRINTER ERROR RESTART THE PRINTER	You tried to print while an error condition was present.	Press the  Power button to turn off the printer. Unplug the printer and wait 30 seconds. Then plug it in and turn it back on.
SERVICE CALL ERROR	If the error code is 1133 or 1137, the print head is locked.	Remove the bracket securing the print head; see page 27.
	If the error code is 3000, a power cord is not plugged into the printer properly.	Press the  Power button to turn off the printer. Unplug the printer and wait 30 seconds. Then plug it in securely and turn it back on. If the message remains, contact Epson as described on page 11.
	An error has occurred.	Note the error number, then turn the printer off. Unplug the printer and wait 30 seconds. Then plug it in and turn it back on. If the message remains, contact Epson as described on page 11.

Solving Operational Problems

If you can't turn the printer on, if it stops printing unexpectedly, or if nothing prints, check the following:

- The printer is plugged securely into a working electrical outlet that's not controlled by a switch or timer.
- The interface cable is securely connected to the printer and your system.
- The voltage supplied by the electrical outlet matches the voltage on the printer's rating label. If not, turn off the power and unplug the power cord immediately. Contact Epson for assistance; see page 11 for details.
- Media is loaded correctly.
- The heaters have reached their selected temperature; this is necessary before printing can start.

If none of these suggestions help, try the solutions below.

Problem	Solution
Printing will not start.	<ul style="list-style-type: none"> • If the heaters have not reached the selected temperature for your media, printing cannot start. Wait for the heaters to reach the desired temperature; see page 112.
The printer stops printing unexpectedly.	<ul style="list-style-type: none"> • If the  Pause light is flashing, the printer is performing a maintenance procedure. Check the display message and lights on the control panel. Wait until the  Pause light stops flashing. • Check the display message and lights on the control panel to see if an error has occurred. Follow the instructions for the messages beginning on page 100.
Nothing prints.	<ul style="list-style-type: none"> • Turn off the printer and computer. Make sure the interface cable is securely plugged in. Then restart the printer and computer. • Make sure the interface cable meets the requirements; see page 11.

Improving Print Quality

Try the solutions in the following table if you need to improve print quality.

Problem	Solution
Your print is grainy, has misregistration or ghosting, or has banding.	<ul style="list-style-type: none"> ▶ Check the ink indicators and light to see if you are low on ink. Replace ink cartridges if necessary, as described on page 75. ▶ Run a nozzle check and cleaning cycle. See page 73 for instructions. ▶ Align the print head; see page 61. ▶ Check that the heater settings are correct for your media; see page 118. ▶ Try adjusting your paper configuration settings. See page 56 for instructions. ▶ If you still have problems with print quality, try cleaning the cleaning wiper and print head casing (see page 79), or replacing the flushing pad (see page 84). If necessary, wash the ink system (see page 86).
Colors are incorrect or missing.	<ul style="list-style-type: none"> ▶ Run a nozzle check and cleaning cycle; see page 73. ▶ Check the expiration date printed on the ink cartridge. If the cartridge is too old, replace it as described on page 75. ▶ Check that the heater settings are correct for your media; see page 118. ▶ Check the ink indicators and light, and replace ink cartridges if your ink supply is low, as described on page 70. ▶ Make sure color settings in your application are correct.
Your print has gaps or appears faint.	<ul style="list-style-type: none"> ▶ Check the expiration date printed on the ink cartridge. If the cartridge is too old, replace it as described on page 75. ▶ Check that the heater settings are correct for your media; see page 118. ▶ Run a nozzle check and cleaning cycle (see page 73). ▶ Check the ink indicators and light and replace ink cartridges if your ink supply is low, as described on page 70. ▶ Try adjusting your paper configuration settings. See page 56 for instructions. ▶ If you still have problems with print quality, try cleaning the cleaning wiper and print head casing (see page 79), or replacing the flushing pad (see page 84). If necessary, wash the ink system (see page 86).

Problem	Solution
Your print appears blurry or smeared.	<ul style="list-style-type: none"> ▶ Try adjusting your paper configuration settings. See page 56 for instructions. ▶ Your media doesn't meet the required specifications or wasn't stored in a dry, humidity-free environment. Load new media. ▶ Check that the heater settings are correct for your media; see page 118. ▶ Ink has leaked into the paper path or onto the pressure rollers. See page 89 for cleaning instructions. ▶ The print head height adjustment lever may be in too high a position for your media. Place the head height adjustment lever in the lower position (see page 54). ▶ Run a nozzle check and cleaning cycle (see page 73). ▶ If you still have problems with print quality, try cleaning the print head cleaning wiper and print head casing (see page 79), or replacing the flushing pad (see page 84). If necessary, wash the ink system (see page 86).

Solving Media Problems

If media feed or media jam problems occur frequently, try one or more of the following solutions:

- Try adjusting the **Paper Suction**, heater settings, and other settings for your media. See page 56 for more information.
- Make sure the media is not folded, wrinkled, or damp. If it tends to curl at the edges, load it using the paper holder plates. See page 48 for instructions.
- Make sure the printer's environment falls within the required temperature and humidity range. See page 121 for details.
- Make sure the media is not too thick or too thin. See page 122 for specifications.
- Make sure no foreign objects are inside the paper path and no paper dust has accumulated on the pressure rollers. See page 89 for instructions.
- Make sure the printer isn't located in a brightly lit area or in direct sunlight; the paper sensors may not operate correctly.

Clearing Media Jams

When media gets jammed in the printer, printing stops and you see a PAPER JAM message on the LCD display. Follow these steps to clear a jam:

1. Turn off the printer.
2. Open the front cover.
3. Slide the print head to the right and off of the jammed media.

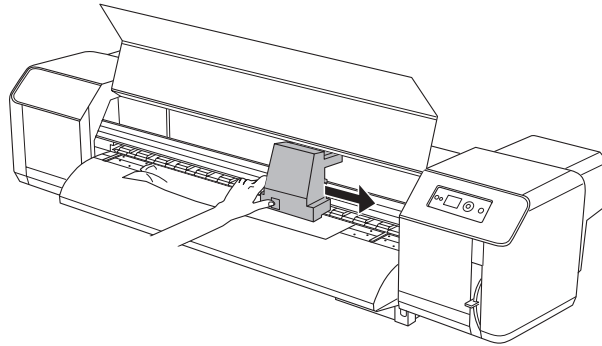

4. Release the paper lever.

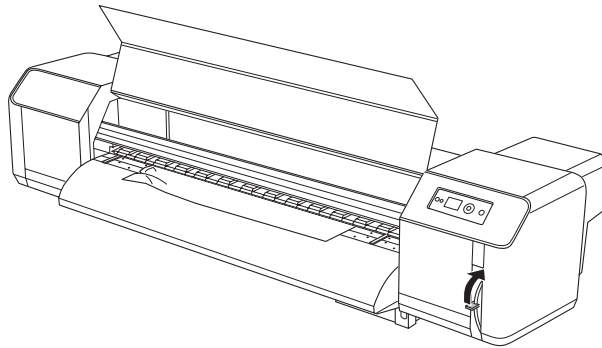

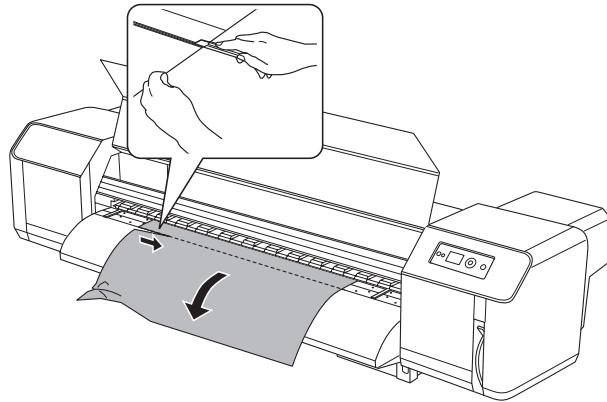

WARNING: Do not place your fingers in the path of the cutting tool to avoid injuring yourself.

5. Using a razor blade or other cutting tool, cut off the media by guiding the tool along the cutting groove in the post heater as shown.

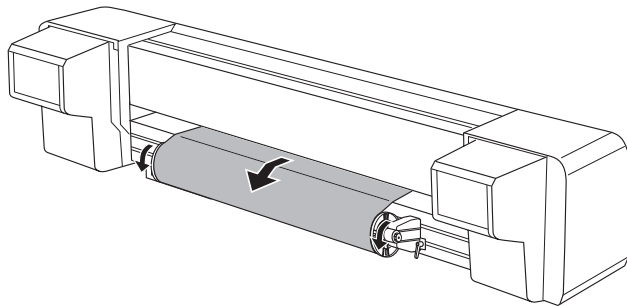

6. Turn the roll backward using the roll paper holders and remove any remaining media from the feed slot.



7. Remove any remaining pieces of torn or jammed media from the printer.
8. Close the front cover.
9. Press the  Power button to turn the printer back on.
10. Make sure the **Check**  paper light is on and the following message appears on the LCD display: **PAPER OUT LOAD PAPER**. Then reload your media.

Appendix A: Printer Parts and Controls Summary

This Appendix identifies the printer parts (below), summarizes the functions of the control panel's lights and buttons (see page 110), describes the messages and icons you may see on the LCD display (see page 113), and lists the available menu settings (see page 114) and Maintenance Mode settings (see page 120).

Printer Parts

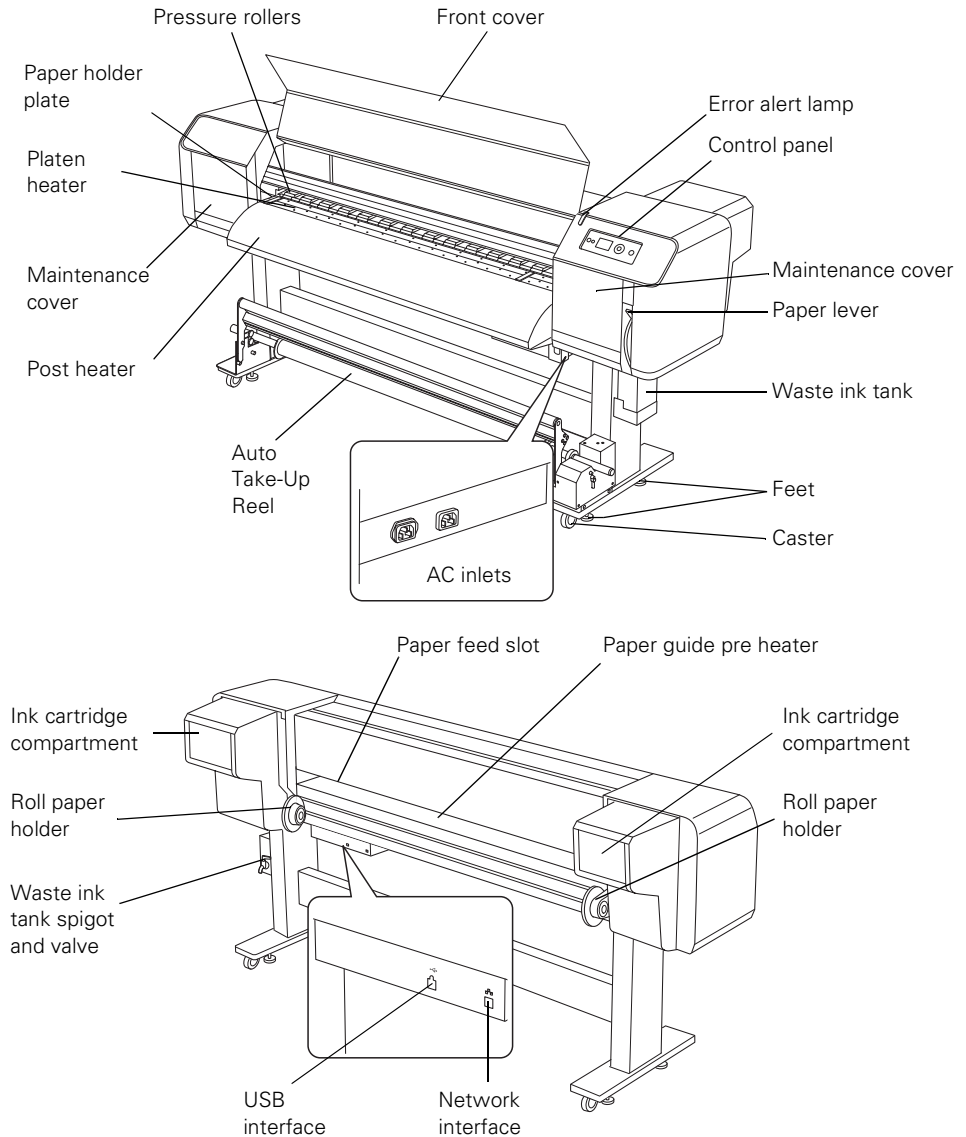

Control Panel Buttons and Lights

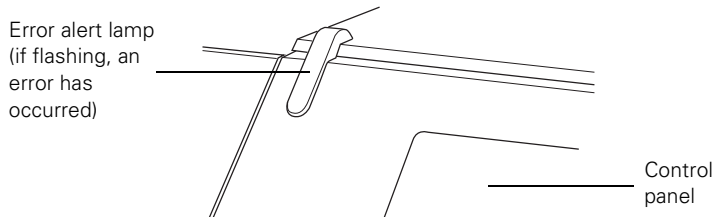
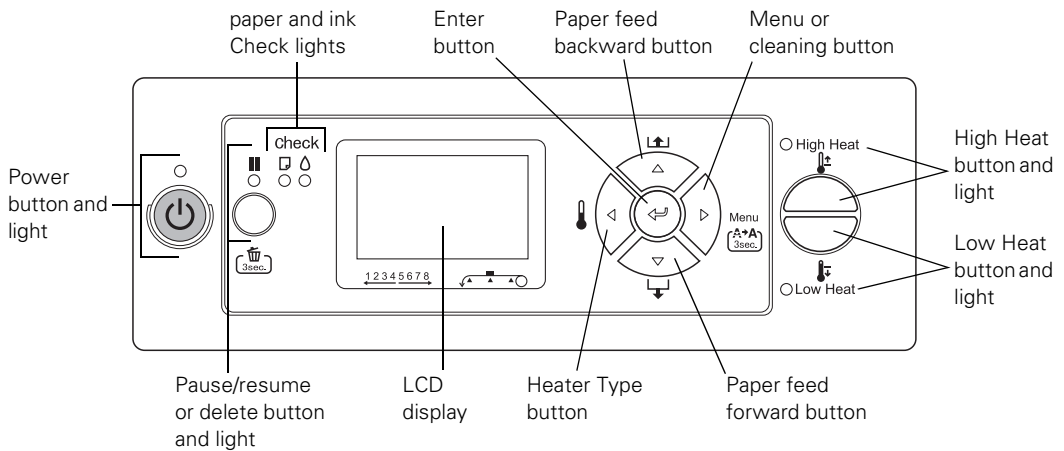

Buttons

Button	Description
⏻ Power	Turns the printer on and off
⏸ Pause	Stops printing temporarily Resumes printing when printing was paused In menu mode, returns the printer to READY state When held for three seconds, deletes the print job
▶ Menu	Accesses the printer menus Selects menus and settings within menu mode During printing, enters the PRINTER STATUS menu When held for three seconds, cleans the print head
◀ Heater Type	Selects the type of heater you want to adjust with High Heat or Low Heat button Goes back to previous menu within menu mode

Button	Description
▼ Paper Feed forward	Feeds the media forward Changes setting parameters within menu mode
▲ Paper Feed backward	Feeds the media backward Changes setting parameters within menu mode
↵ Enter	Executes setting changes within the menu system
High Heat	Increases the preset temperature of the currently selected heater type (selected with the ◀ Heater Type button and indicated on the LCD display)
Low Heat	Decreases the preset temperature of the currently selected heater type (selected with the ◀ Heater Type button and indicated on the LCD display)

Lights

See “Checking Error Messages and Lights” on page 100 for instructions on responding to problems indicated by the printer lights.

Light	Description
Ⓞ Power	On: printer is turned on Flashing: printer is processing or printing a print job, performing a cleaning operation, warming up, or shutting down Off: printer is turned off
⏸ Pause	On: printer is paused or in menu mode
Check 📄 Paper	On: no media is loaded, media is out, or the paper lever is in the Released position Flashing: media is jammed, almost out, loaded crooked, or there is another error condition
Check ⚠ Ink	On: an ink cartridge is expended, not installed, or not compatible with the printer Flashing: an ink cartridge is nearly expended
High Heat	See the next two tables for descriptions
Low Heat	
Error alert lamp	Flashing: an error has occurred

Status of **High Heat** and **Low Heat** lights when the printer is in a **READY** or **WARMING UP** state:

High Heat light	Low Heat light	Description
On	On	All three heaters have reached their preset temperature
Flashing	Off	At least one of the heaters is warming up to its preset temperature
Flashing	Flashing	A heater error has occurred
Off	Off	All three heaters are turned off







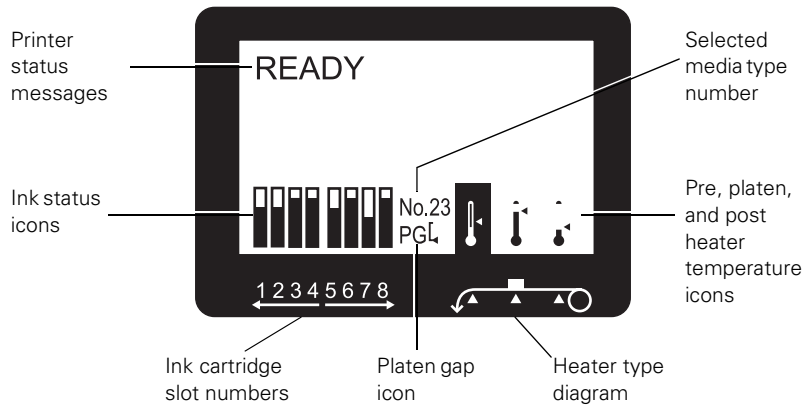



Status of **High Heat** and **Low Heat** lights when selecting a preset temperature for a heater (currently selected heater type is indicated on the control panel):

High Heat light	Low Heat light	Description
On	On	You can select a higher or lower temperature than the current setting
On	Off	You can select only a higher temperature than the current setting
Off	On	You can select only a lower temperature than the current setting

LCD Display Icons



The table below describes the icons that appear on the LCD display:

Icon	Description
Ink icons	
 or 	Plenty of ink is available
 or 	Ink is getting low; make sure you have a new cartridge
Flashing 	Ink is low (example shows the yellow cartridge)
	Ink is expended (example shows the yellow cartridge)
	Cartridge error or no cartridge
Platen gap (print head height) icons	
	High
	Low
Heater icons	
	Arrow and numeric value indicate preset temperature target; thermometer icon level indicates current heater temperature

For a list of error messages that may appear on the LCD display and instructions on correcting any problems they may indicate, see “Checking Error Messages and Lights” on page 100.

Menu Setting Summary

Press the Menu button to enter menu mode and select the settings summarized here.

Menu setting	Description
PRINTER SETUP menu	
SIDE MARGIN	Selects the margins for the left and right sides. 0.20inch to 1.00inch (5mm to 25mm)
PAPER SIZE CHECK	Selects whether the printer checks to see if the width and top edge of the loaded media matches data for your print job (ON is recommended to avoid ink overspray).
PAPER SKEW CHECK	Selects whether the printer alerts you if media is not feeding straight by displaying PAPER SKEW on the LCD display and stopping printing. If you select OFF , you do not receive an error even if the print job is out of range of the loaded media.
PRINT NOZZLE PATTERN	Selects whether to automatically print the nozzle check pattern before printing each print job or before every tenth sheet. OFF ON: EVERY PAGE ON: EVERY 10 PAGES
HEATING TIME	Selects the length of time to preheat the heaters. (The heaters turn off after this time has passed after turning on the printer or finishing a print job.) OFF 10min to 240min
FLUSH ONTO PAPER	Selects where to perform the flushing operation during printing. YES to flush at the page margins (speeds up printing by avoiding print head returns to the flushing box; set frequency below) NO to flush only at the flushing box
FLUSHING FREQUENCY	Selects how often to perform the flushing operation at the flushing box (if YES selected above). 5PASS for every five passes of the print head 1PASS to 999PASS

Menu setting	Description
PAPER ORIGIN SETUP	Selects the beginning point (origin) for printing (horizontal) 0.00inch to 32.00inch (0mm to 800mm)
AUTO TAKE-UP REEL	Controls media feeding when using the Auto Take-Up Reel. ON prevents feeding the media backward from the Auto Take-Up Reel OFF to turn off this function if you remove the Auto Take-Up Reel
HEAD FAN	Controls operation of the head fan. Leave this setting turned ON .
REGULAR CLEANING	Selects the interval at which to automatically clean the print head after completing a print job to retain print quality (in hours). The timer is reset when the printer is turned off and on, the interval is changed, or you clean the print head manually. OFF 1h to 6h, 9h, 12h, 18h, 24h
INITIALIZE SETTINGS	Resets the PRINTER SETUP menu settings to their default settings.
PAPER SETUP menu (see page 117 for details)	
PAPER TYPE	Selects the type of media you want to print on.
PAPER SETUP	Selects whether to print with default settings for all media setup options (STANDARD) or to set up a paper number (1 to 30) with custom settings (recommended).
MAINTENANCE menu	
CLEANING (VERY LIGHT)	Starts a very light print head cleaning cycle (uses less ink than LIGHT cleaning cycle); see page 74 for details.
CLEANING (LIGHT)	Starts a standard print head cleaning cycle; see page 74 for details.
CLEANING (MEDIUM)	Starts a strong print head cleaning cycle when a LIGHT cleaning cycle does not unclog the print head fully (uses more ink than LIGHT cleaning cycle); see page 74 for details.

Menu setting	Description
CLEANING (HEAVY)	Starts the strongest print head cleaning cycle when a MEDIUM cleaning cycle does not unclog the print head fully (uses more ink than MEDIUM cleaning cycle); see page 74 for details.
HEAD WASHING	Starts the print head washing cycle using the cleaning cartridges; see page 86 for details.
CARRIAGE MAINTENANCE	Moves the print head to the maintenance position so you can clean its cleaning wiper; see page 79 for details.
CLOCK SETTING	Sets the printer date and time settings.
CONTRAST ADJUSTMENT	Adjusts the contrast of the LCD display.
TEST PRINT menu	
NOZZLE CHECK	Prints a nozzle check pattern, including the firmware version and ink usage count; see page 73 for details.
STATUS SHEET	Prints a sheet showing the status of various printer parts and settings; see page 71 for details.
NETWORK STATUS SHEET	Prints a sheet showing the network settings
JOB INFORMATION	Prints a sheet showing information about the last 10 print jobs.
CUSTOM PAPER	Prints information about paper configurations you have created; see page 56 for details.
PRINTER STATUS menu (see page 71 for details)	
VERSION	Displays the printer's firmware version number.
PRINTABLE PAGES	Displays an estimate of the number of pages that can be printed based on the ink cartridge status.
INK LEVEL	Displays the status of the ink in the cartridges.
USAGE COUNT	Displays the approximate amount of ink and media used.
CLEAR USAGE COUNT	Clears the values displayed in USAGE COUNT .
JOB HISTORY	Displays the approximate amount of ink and media used in the last 10 print jobs.
TOTAL PRINTS	Displays the total number of pages printed.

Menu setting	Description
EDM STATUS	Displays whether the EDM system is disabled or enabled, and the date and time the EDM status was last uploaded. See www.myeppsonprinter.com for more information.
NETWORK SETUP menu	
NETWORK SETUP	Select to enable or disable network printing.
IP ADDRESS SETTING	Select to set the IP address automatically (AUTO) or manually (PANEL).
IP, SM, DG SETTING	Enter the IP address settings, if selecting the address manually.
BONJOUR	Select the Bonjour network settings, if necessary.
INIT NETWORK SETTING	Returns the network settings to their default settings.

Paper Setup Option Summary

In the **PAPER SETUP** menu, select your paper configuration number, then select these paper setup options for that media type:

Option and parameters	Description
PRINT MODE	
MAX QUALITY	For photo printing with priority on print quality.
QUALITY1	For photo printing balancing print quality and efficiency.
QUALITY2	For photo printing with priority on efficiency.
QUALITY3	For graphic printing with standard print quality.
SPEED1	For faster printing of text or graphics with priority on print quality.
SPEED2	For faster printing of text or graphics balancing print quality and efficiency.
SPEED3	For faster printing of text or graphics with priority on efficiency.
PAPER FEED ADJUST	
LINE FEED ADJUST	Adjusts the amount of media fed during printing to help eliminate banding. See page 59 for details.
PRINT SAMPLE PATTERN	

Option and parameters	Description
HEAD ALIGNMENT	
BI-D ALL	Adjusts the alignment of the print head to help eliminate vertical misalignment. See page 61 for details.
PRE HEATER	
OFF 30°C to 50°C (86 °F to 122 °F)	Sets the temperature of the heater that heats the media before printing. See the instructions that came with your media to select the correct temperature for the pre heater. <div data-bbox="868 586 1182 803" data-label="Image"> </div>
PLATEN HEATER	
OFF 30°C to 50°C (86 °F to 122 °F)	Sets the temperature of the heater beneath the print head that warms the ink. See the instructions that came with your media to select the correct temperature for the platen heater. <div data-bbox="861 1020 1196 1237" data-label="Image"> </div>

Note: All three heaters must reach the selected temperature before printing can start.

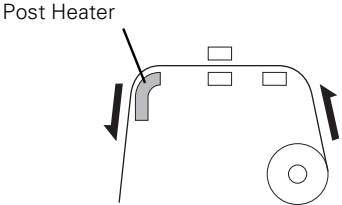
Option and parameters	Description
POST HEATER	
<p>OFF</p> <p>30°C to 50°C (86 °F to 122 °F)</p>	<p>Sets the temperature of the heater that dries the printout. See the instructions that came with your media to select the correct temperature for the post heater.</p> 
M/W ADJUSTMENT (MicroWeave adjustment)	
<p>LOW A to B</p>	<p>Minimizes the affect of the MicroWeave adjustment. Select LOW B if white lines or uneven print density is evident in prints using LOW A.</p>
<p>MEDIUM A to D</p>	<p>Prints areas between print head passes with a wave form pattern. Select MEDIUM B, C, or D if white lines or uneven print density is evident in prints using MEDIUM A.</p>
<p>HIGH A to D</p>	<p>Prints like MEDIUM M/W ADJUSTMENT, but slower to improve print quality. Select HIGH B, C, or D if white lines or uneven print density is evident in prints using HIGH A.</p>
<p>EXTRA HIGH A to B</p>	<p>Prints like HIGH M/W ADJUSTMENT, but only on half of the print head nozzles (EXTRA HIGH A uses one half and EXTRA HIGH B uses the other half). Select EXTRA HIGH to improve print quality over HIGH printing.</p>
PAPER SUCTION	
<p>HIGH</p> <p>LOW</p>	<p>Adjusts the suction pressure used when feeding the media. See the instructions that came with your media to select the correct suction pressure for it.</p>
DRYING TIME	
<p>0.0sec to 10.0sec</p>	<p>Selects a drying time for ink to avoid smearing.</p>

Option and parameters	Description
CARRIAGE MOVEMENT	
DATA WIDTH	Sets the print head to move only to the width of the print data to improve print speed.
PRINTER FULL WIDTH	Sets the print head to move the maximum width at all times to improve print consistency for certain types of images.
PRINT MULTIPLE LAYER	
OFF	Sets printing to overwrite lines a select number of times for greater density (also called "multiple hit").
2 to 8	

Using Maintenance Mode

Maintenance mode allows you to customize the control panel language, change units of measurement and temperature, and return all of the printer's control panel settings to their default values

1. Make sure the printer is turned off.
2. Press and hold the **||** Pause button, then press the **⏻** Power button and hold it until the printer turns on and the LCD displays **MAINTENANCE MODE**.
3. Select the following settings as necessary:

Setting	Description
LANGUAGE	Select the language displayed by the control panel.
LENGTH UNIT	Select METRIC or FEET/INCH units of measurement displayed by the control panel.
THERMOMETER UNIT	Select °C or °F units of temperature displayed by the control panel.
DEFAULT PANEL	Returns all control panel settings to their default values.

4. Press the **⏻** Power button to turn off the printer.
5. Press the **⏻** Power button again to turn on the printer in normal mode.

Appendix B: Specifications

Environmental

	Operation	Storage
Temperature	68 to 90 °F (20 to 32 °C) Print quality guarantee: 72 to 90 °F (22 to 32 °C)	14 to 104 °F (-10 to 40 °C) (4 days at 90 °F [32 °C])
Humidity (without condensation)	40 to 60% RH Print quality guarantee: 40 to 60%	20 to 80% RH (stored in shipping container)

Note: We recommend that you use genuine Epson cartridges and do not refill them. The use of other products may affect your print quality and could result in printer damage.

Yields vary considerably based on images printed, print settings, paper type, frequency of use, and temperature. For print quality, a small amount of ink remains in the cartridge after the "replace cartridge" indicator comes on. The printer ships with full cartridges and part of the ink from this first set of cartridges is used for priming the printer.

Electrical

Specification	Description
Input voltage range	90 V to 132 V
Rated frequency range	50 to 60 Hz
Input frequency range	49 to 51 Hz
Rated current	Main: 11 A Heater: 11 A
Power consumption	Printing: Approx. 680 W Ready mode: Approx. 680 W (idle, heat On) Approx. 48 W (idle heat Off) Sleep mode: Approx. 24 W Power Off mode: Approx. 3W

Check the label on the back of your printer for voltage information.

Dimensions and Weight

Specification	Description
Height	49.9 inches (1267 mm)
Width	106.2 inches (2698 mm)
Depth	37.1 inches (943 mm) 41.1 inches (1045 mm) with Auto Take-Up Reel
Weight (without ink cartridges)	331 lb (150 kg) printer 75 lb (34 kg) stand 42 lb (19 kg) Auto Take-Up Reel

Printer Interfaces

- USB (1.1 and 2.0 compatible)
- Ethernet 10/100/1000 BaseT

Safety Approvals

Safety standards	UL 60950-1 CSA 22.2 No. 60950-1
EMC	FCC part 15 subpart B, class A CAN/CSA-CEI/IEC CISPR 22 Class A

Media

Media width	12 to 64 inches (300 to 1625 mm)
Maximum media thickness	0.01 inches (0.3 mm); Low head height adjustment 0.05 inches (1.3 mm); High head height adjustment
Core diameter	3 inches (76 mm)
Maximum external roll diameter	6.7 inches (170 mm)
Maximum roll weight	66 lb (30 kg)

Ink Cartridges

Colors	Cyan, Magenta, Yellow, Black, Light Cyan, Light Magenta, Green, Orange
Cartridge life	See production date on package, if unopened Within 6 months after opening package
Temperature (storage)	Uninstalled: -4 to 104 °F (-20 to 40 °C) 1 month at 104 °F (40 °C) Installed: 14 to 104 °F (-10 to 40 °C) 4 days at 90 °F (32 °C)
Capacity:	950 ml
Dimensions (W × D × H)	2.09 × 12.4 × 5.75 inches (53.1 × 316.1 × 146.2 mm)

Index

A

- Accessories, 10
- Aligning print head, 61 to 62
- Assembling
 - Auto Take-Up Reel, 24 to 26
 - printer, 17 to 23
 - stand, 18 to 20
- Auto Take-Up Reel, *see* Take-Up Reel, Auto

B

- Banding, 105
- Bracket, shipping
 - installing for transport, 94, 95
 - removing, 29
- Buttons, control panel, 100, 110 to 111

C

- Cables
 - power, 31 to 32
 - printer, 37
 - problems, 104
 - requirements, 11
- Cartridges, *see* Ink cartridges, or *Cleaning cartridges*
- Check ink light, 70, 77, 100
- Check paper light, 100, 108
- Checking
 - error messages, 100 to 103
 - ink status, 70
 - lights, 100
 - nozzles, 53, 73
 - printer status, 70 to 72
 - waste ink status, 78
- Cleaning
 - cleaning wiper and print head casing, 79 to 84
 - print head nozzles, 74 to 75
 - printer, 89 to 90

- Cleaning cartridges
 - installing, 33 to 35, 86 to 87
 - ordering, 10
- Cleaning wiper, cleaning, 79 to 84
- Color problems, 105
- Configuring media, 56 to 58
- Connecting printer, 37
- Control panel
 - buttons, 100, 110 to 111
 - changing language, 120
 - changing measurement units, 120
 - illustration, 100, 110
 - ink levels, checking, 70, 70 to 72, 113
 - LCD display, 113
 - lights, 100, 110 to 112
 - messages, 100 to 103
 - restoring default settings, 120
- Cutting off prints, 62 to 63

D

- Default settings, restoring, 120
- Depth of printer, 122
- Diagnosing problems, 99
- Dimensions of printer, 122
- Disposing of waste ink, 16, 78 to 79, 95
- Documentation, how to use, 9

E

- Electrical specifications, 121
- Energy consumption, 121
- Environmental specifications, 121
- Epson
 - accessories, 10
 - help, 11
 - Preferred Limited Warranty Plan, 11
- Epson NetConfig, 39 to 40
- Error alert lamp, 110 to 111
- Error messages, 100 to 103

Ethernet
 connecting, 37
 port specification, 122
 requirements, 11

F

Feeding position, adjusting, 59 to 60
 Firmware, updating, 38 to 39
 Flushing pad, replacing, 84 to 86

H

Head washing, 86 to 87, 95
 Heaters
 buttons, 100, 110 to 112
 cleaning, 90
 electrical specifications, 121
 icons, 113
 lights, 100, 110 to 112
 location, 109
 safety instructions, 13
 settings, 56 to 58, 114, 118 to 119
 Height
 of print head, 54 to 55
 of printer, 122
 Help, Epson, 11
 Humidity requirements, 121

I

Icons, 113
 Ink
 icons, 70, 113
 light, 100, 111
 Ink cartridges
 checking status, 70
 installing, 33 to 36, 86 to 87
 ordering, 75
 removing for transportation, 93, 95
 replacing, 75 to 77
 safety instructions, 15 to 16
 specifications, 123
 Ink cleaning, using, 81 to 84
 Ink light, 70, 111

Ink system
 maintaining, 69 to 87
 washing, 86 to 87, 95
 Ink, waste *see* Waste ink
 Interface specifications, 122

J

Jams, media, 107 to 108
 Job history, 72

L

Language, control panel, 120
 LCD display, 113
 Length units, 120
 LFP Remote Panel, 38 to 39
 Lights, control panel, 100, 110 to 112
 Loading media, 42 to 49

M

Maintenance, 69 to 87
 Maintenance menu, 74, 80, 85, 115
 Maintenance Mode, 120
 Manuals, how to use, 9
 Media
 configuration settings, 56 to 58
 cutting off, 62 to 63
 feeding position, 59 to 60
 jams, 107 to 108
 lever, 43, 48
 loading, 42 to 49
 paper holder plates, 48
 printing checklist, 58
 problems, 106 to 108
 replacing roll, 66 to 67
 selecting, 41 to 42
 sizes, 122
 specifications, 122
 using with Auto Take-Up Reel,
 49 to 53, 64 to 65
 Memory, requirements, 11

Menus

- Maintenance, 74, 80, 85, 115
- Network Setup, 117
- Paper Setup, 56 to 58, 117 to 120
- Printer Setup, 114 to 115
- Printer Status, 38, 71 to 72, 116
- setting summary, 114 to 117
- Test Print, 71, 73, 116

Messages, control panel, 100 to 103

Moving printer, 91 to 92

N

Network

- configuring software, 39 to 40
- connection, 37

Network Setup menu, 117

Nozzle Check, 53, 73

O

Operation problems, 104

Options and accessories, 10

P

Pad, flushing, replacing, 84 to 86

Paper holder plates, 48

Paper lever, 43, 48

Paper light, 100, 111

Paper Setup menu, 56 to 58,
117 to 120

Parts, printer, 109

Pause light, 100, 110 to 111

Platen gap, 54 to 55, 113

Power cables, 31 to 32

Power consumption, 121

Power light, 100, 110 to 111

Print head

- adjusting height, 54 to 55
- aligning, 61 to 62
- casing, cleaning, 79 to 84
- cleaning wiper, cleaning, 79 to 84

Print head (*continued*)

- cleaning, nozzles, 74 to 75
- locking, 94, 95
- unlocking, 29

Print Head Cleaning Kit

- ordering, 10
- using, 81 to 84

Print quality problems, 105 to 106

Printable pages, checking, 72

Printer

- cable, 37
- checking status, 71 to 72
- checklist, 58
- cleaning, 89 to 90
- connecting, 37
- default settings, restoring, 120
- dimensions and weight, 122
- firmware update, 38 to 40
- maintaining, 69 to 87
- moving, 91 to 92
- parts, 109
- placing on stand, 21 to 23
- plugging in, 31 to 32
- safety instructions, 12 to 16
- shipping, 93 to 95
- software, installing, 37
- space around, 17
- specifications, 121 to 123
- stand, *see* Stand, printer status, checking, 70 to 72
- storing, 91
- total print volume, 72
- transporting, 91 to 95
- turning off, 13
- unpacking, 17, 27 to 29

Printer Maintenance Kit

- ordering, 10
- using, 79 to 84

Printer Setup menu, 114 to 115

Printer Status menu, 38, 71 to 72, 116

Problems

- banding, 105
- cables, 104
- color, 105

Problems (*continued*)

- diagnosing, 99
- media, 106 to 108
- misalignment, 105
- nothing prints, 104
- operational, 104
- print quality, 105 to 106
- printing stops, 104
- solving, 99 to 108

R

- Registering media, 56 to 58
- Replacement core, Auto Take-Up Reel, 10
- Requirements, system, 11
- Rolls, replacing, 66 to 67

S

- Safety
 - approvals, 122
 - instructions, 12 to 16
- Shipping bracket
 - installing, 94, 95
 - removing, 29
- Shipping printer, 93 to 95
- Software, installing, 37
- Specifications
 - dimensions and weight, 122
 - electrical, 121
 - environmental, 121
 - ink cartridges, 123
 - interface, 122
 - media, 122
 - printer, 121 to 123
 - safety approvals, 122
- Stand, printer
 - assembling, 18 to 20
 - placing printer on, 21 to 23
 - stabilizing, 30
- Status, checking
 - ink, 70
 - printer, 70 to 72
 - waste ink, 78

- Storing printer, 91
- Support, Epson, 11
- System
 - connecting to, 37
 - requirements, 11

T

- Take-Up Reel, Auto
 - attaching media to, 49 to 53
 - core, replacement, 10
 - installing, 24 to 26
 - plugging in, 31 to 32
 - removing prints from, 64 to 65
- Technical support, 11
- Temperature
 - requirements, 121
 - units, 120
- Test Print menu, 71, 73, 116
- Total prints, checking, 72
- Transporting printer, 91 to 95
- Troubleshooting, 99 to 108

U

- UltraChrome GS ink cartridges, 75
- Unit ID number, 11
- Unpacking printer, 27 to 29
- Usage count, 72
- USB cable, 11, 37, 122

W

- Warranty, 10
- Washing ink system, 86 to 87, 95
- Waste ink
 - checking status, 78
 - disposal, 16, 78 to 79, 95
 - safety instructions, 16, 78
 - tank, installing, 23
- Waste ink bottle, 10, 78 to 79
- Weight of printer, 122
- Width of printer, 122
- Windows system requirements, 11