

QSFP-40GBASE-PSM4-AO

MSA and TAA 40GBase-PSM4 QSFP+ Transceiver (SMF, 1310nm, 2km, MPO, DOM)

Features

- SFF-8436 Compliance
- MPO Connector
- Commercial Temperature 0 to 70 Celsius
- Single-mode Fiber
- Hot Pluggable
- Excellent ESD Protection
- Metal with Lower EMI
- RoHS Compliant and Lead Free



Applications

- 40GBase Ethernet
- Access and Enterprise

Product Description

This MSA Compliant QSFP+ transceiver provides 40GBase-PSM4 throughput up to 2km over single-mode fiber (SMF) using a wavelength of 1310nm via an MPO connector. It is built to MSA standards and is uniquely serialized and data-traffic and application tested to ensure that they will integrate into your network seamlessly. Digital optical monitoring (DOM) support is also present to allow access to real-time operating parameters. This transceiver is Trade Agreements Act (TAA) compliant. We stand behind the quality of our products and proudly offer a limited lifetime warranty.

AddOn's transceivers are RoHS compliant and lead-free.

TAA refers to the Trade Agreements Act (19 U.S.C. & 2501-2581), which is intended to foster fair and open international trade. TAA requires that the U.S. Government may acquire only "U.S. – made or designated country end products."



Regulatory Compliance

- ESD to the Electrical PINs: compatible with MIL-STD-883E Method 3015.4
- ESD to the LC Receptacle: compatible with IEC 61000-4-3
- EMI/EMC compatible with FCC Part 15 Subpart B Rules, EN55022:2010
- Laser Eye Safety compatible with FDA 21CFR, EN60950-1& EN (IEC) 60825-1,2
- RoHS compliant with EU RoHS 2.0 directive 2015/863/EU

Absolute Maximum Ratings

Parameter	Symbol	Min.	Typ.	Max.	Unit
Supply Voltage	Vcc	0		+3.6	V
Storage Temperature	Tst	-40		+85	°C
Humidity (non-condensing)	Rh	5		85	%

Recommended Operating Conditions

Parameter	Symbol	Min.	Typ.	Max.	Unit
Power Supply Voltage	Vcc	3.13	3.3	3.47	V
Operating Case Temperature	Tca	0	25	+70	°C
Data Rate Per Channel				10.3125	Gbps
Power Supply Voltage	Vcc	3.135	3.3	3.465	%
Power Supply Current				2.5	W

Electrical Characteristics

Parameter	Symbol	Min.	Typ.	Max.	Unit	Notes
Transmitter Differential Input Voltage	V _{IN}	180		800	mV _{pp}	
Receiver Differential Output Voltage	V _O	400	450	850	mV _{pp}	1
Loss of Signal (LOS)	V _{CH}	2		Vcc	V	2
	V _{OL}	Vee		Vee + 0.8		
Transmitter Disable (TX-Disable)	V _{IH}	2		Vcc	V	
	V _{IL}	Vee		Vee + 0.8		
Rx Output Rise and Fall Time	Tr/Tf	28			Ps	20% to 80%

Notes:

1. SFF-8431, SFP+Module receiver output specifications at C'.

2. LOS is an open collector output. Should be pulled up with 4.7kΩ – 10kΩ on the host board. Normal operation is logic 0; loss of signal is logic 1.

Optical Characteristics

Parameter	Symbol	Unit	Min.	Typ.	Max.	Notes
Transmitter						
Average Launch Power, each lane	Po	dBm	-8.2		+0.5	
Center wavelength	λ_c	nm	1260		1355	
Optical Spectral Width (RMS)	$\Delta\lambda$	nm			2.5	
Extinction ratio	ER	Db	3.0			
Optical power OMA, each lane	POMA	dBm	-5.2		+1.5	1
Average launch power of OFF transmitted, each lane	Poff	dBm			-30	
RIN _{OMA}	RIN	dB/Hz			-128	
Optical return loss tolerance	ORL _T	dB	12			2
Output eye		Compliant with IEEE802.3ba eye mask				
Receiver						
Center Wavelength	λ_c	nm	1260		1355	
Receiver Overload in OMA, each lane	RxOMA	dBm	+1.5			
Receiver Overload in average power, each lane	Pmax	dBm	+0.5			3
Average receive power, each lane	RxPx	dBm	-11.5			4
Receiver Sensitivity in OMA, each lane	Sen _{OMA}	dBm			-9.5	5, for 1.0km type
Receiver Sensitivity in OMA, each lane	Sen _{OMA}	dBm			-10.5	5, for 1.5km type
Receiver Crossing	RCP	%	45		55	
Receiver Eye Mask	SFF-8431, SFP+MODULE RECEIVER OUTPUT SPECIFICATIONS AT C'.					
Receiver Eye Mask Margin	REMM	%	0			
Receiver Reflectance	Rrx	dB			-12	
LOS	Assert	LOSA	dBm	-30		
	De-assert	LOSD	dBm			-12
LOS Hysteresis	LOSH	dB	0.5		6	

Notes:

1. Even if the TDP < 1 dB, the OMA (min) must exceed this value.
2. Transmitter reflectance is defined looking into the transmitter
3. The receiver shall be able to tolerate, without damage, continuous exposure to an optical input signal having a power level equal to the average receive power (max) plus at least 1 dB.

4. Average receive power (min) is informative and not the principal indicator of signal strength. A received power below this value cannot be compliant; however, a value above this does not ensure compliance.
5. PRBS 231 -1 at BER 10-12 , ER=3.0dB

Digital Diagnostic Memory Map

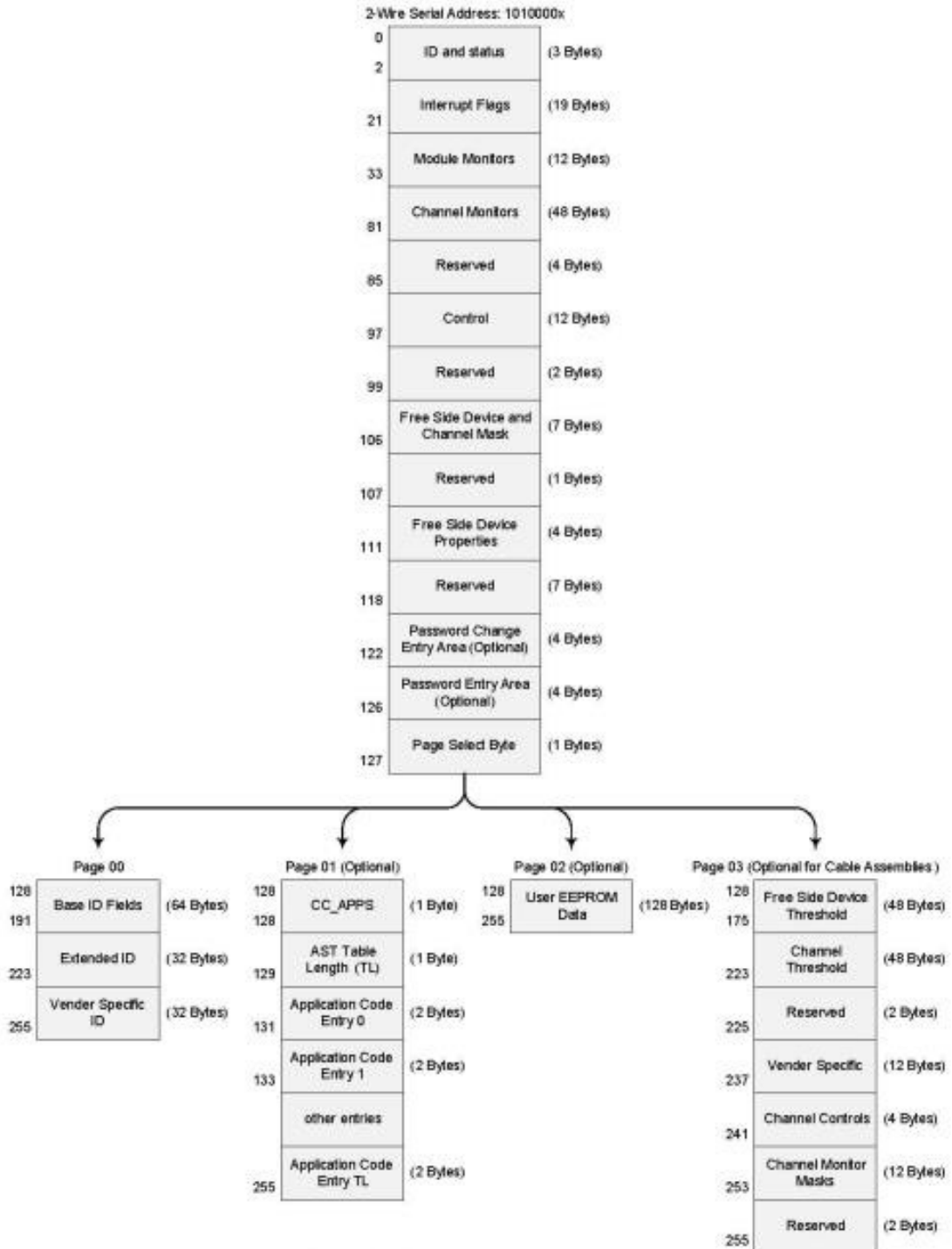

Pin Descriptions

Pin	Logic	Symbol	Name/Descriptions	Ref.
1		GND	Module Ground	1
2	CML-I	Tx2-	Transmitter inverted data input	
3	CML-I	Tx2+	Transmitter non-inverted data input	
4		GND	Module Ground	1
5	CML-I	Tx4-	Transmitter inverted data input	
6	CML-I	Tx4+	Transmitter non-inverted data input	
7		GND	Module Ground	1
8	LVTTTL-I	MODSEIL	Module Select	2
9	LVTTTL-I	ResetL	Module Reset	2
10		VCCRx	+3.3v Receiver Power Supply	
11	LVCNOS-I	SCL	2-wire Serial interface clock	2
12	LVCNOS-I/O	SDA	2-wire Serial interface data	2
13		GND	Module Ground	1
14	CML-O	RX3+	Receiver non-inverted data output	
15	CML-O	RX3-	Receiver inverted data output	
16		GND	Module Ground	1
17	CML-O	RX1+	Receiver non-inverted data output	
18	CML-O	RX1-	Receiver inverted data output	
19		GND	Module Ground	1
20		GND	Module Ground	1
21	CML-O	RX2-	Receiver inverted data output	
22	CML-O	RX2+	Receiver non-inverted data output	
23		GND	Module Ground	1
24	CML-O	RX4-	Receiver inverted data output	
25	CML-O	RX4+	Receiver non-inverted data output	
26		GND	Module Ground	1
27	LVTTTL-O	ModPrsL	Module Present, internal pulled down to GND	
28	LVTTTL-O	IntL	Interrupt output should be pulled up on host board	2
29		VCCTx	+3.3v Transmitter Power Supply	
30		VCC1	+3.3v Power Supply	
31	LVTTTL-I	LPMODE	Low Power Mode	2
32		GND	Module Ground	1
33	CML-I	Tx3+	Transmitter non-inverted data input	
34	CML-I	Tx3-	Transmitter inverted data input	
35		GND	Module Ground	1
36	CML-I	Tx1+	Transmitter non-inverted data input	
37	CML-I	Tx1-	Transmitter inverted data input	
38		GND	Module Ground	1

Notes:

1. GND is the symbol for signal and supply (power) common for QSFP+ modules. All are common within the QSFP+ module and all module voltages are referenced to this potential unless otherwise noted. Connect these directly to the host board signal common ground plane.
2. VccRx, Vcc1 and VccTx are the receiver and transmitter power suppliers and shall be applied concurrently. Recommended host board power supply filtering is shown in the figure below. Vcc Rx, Vcc1 and VccTx may be internally connected within the QSFP+ transceiver module in any combination. The connector pins are each rated for a maximum current of 500mA.

Electrical Pin-out Details

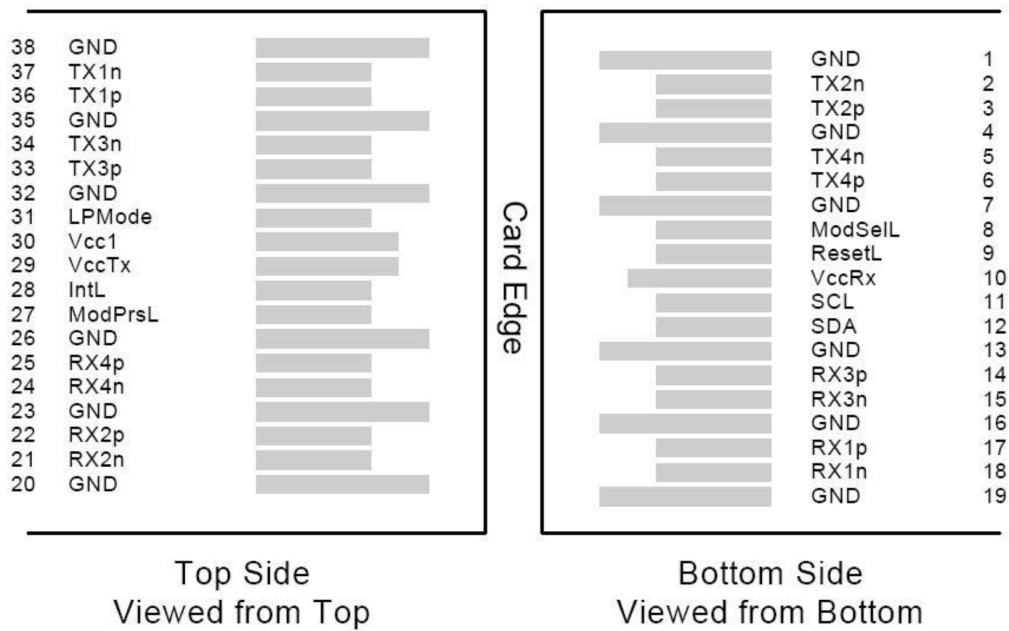

Recommended Power Supply Filter

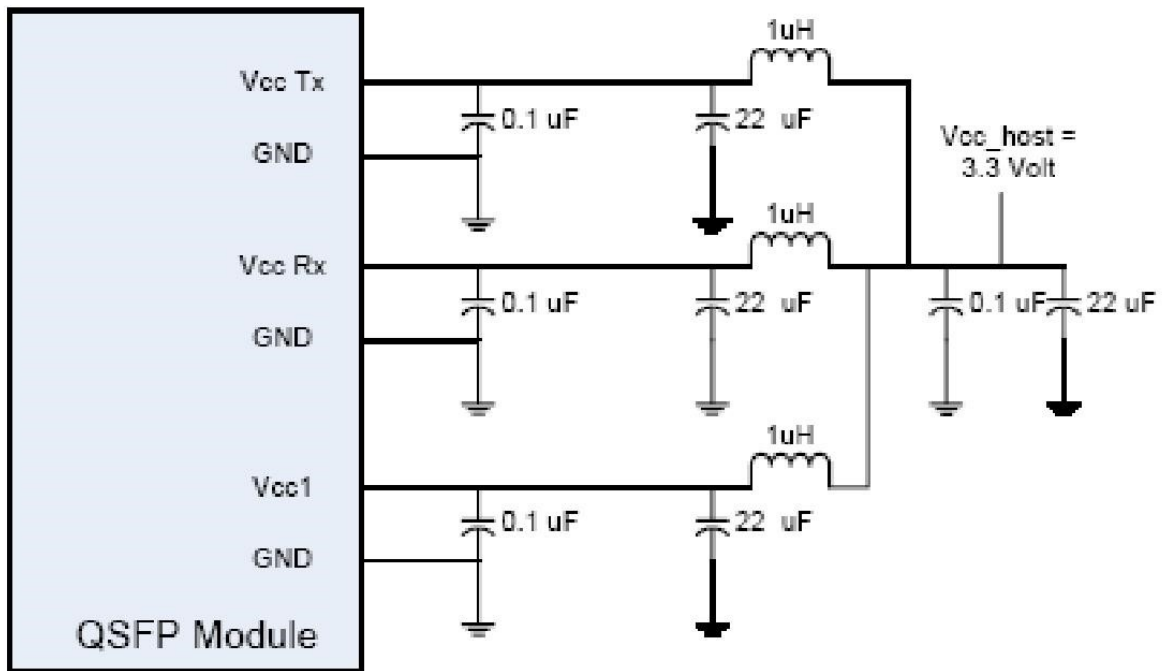

Mechanical Specifications

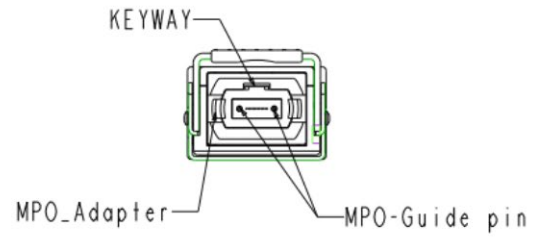
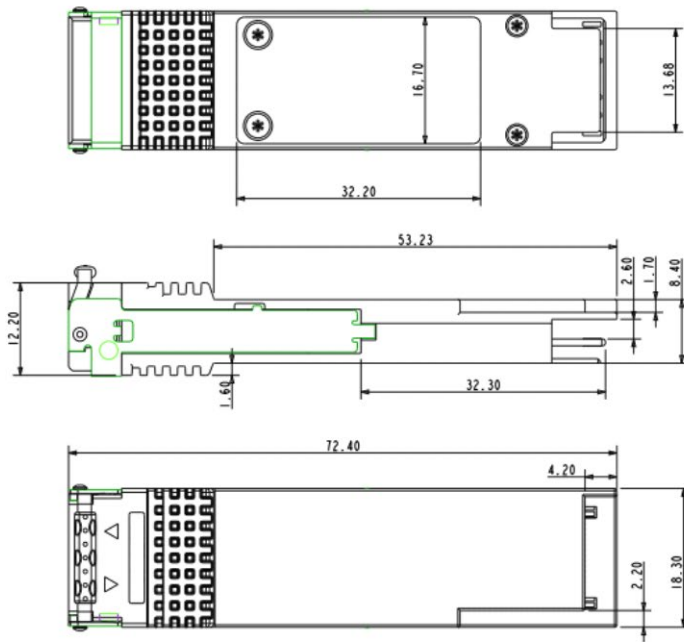

About AddOn Networks

In 1999, AddOn Networks entered the market with a single product. Our founders fulfilled a severe shortage for compatible, cost-effective optical transceivers that compete at the same performance levels as leading OEM manufacturers. Adhering to the idea of redefining service and product quality not previously had in the fiber optic networking industry, AddOn invested resources in solution design, production, fulfillment, and global support.

Combining one of the most extensive and stringent testing processes in the industry, an exceptional free tech support center, and a consistent roll-out of innovative technologies, AddOn has continually set industry standards of quality and reliability throughout its history.

Reliability is the cornerstone of any optical fiber network and is engrained in AddOn's DNA. It has played a key role in nurturing the long-term relationships developed over the years with customers. AddOn remains committed to exceeding industry standards with certifications from ranging from NEBS Level 3 to ISO 9001:2005 with every new development while maintaining the signature reliability of its products.

U.S. Headquarters

Email: sales@addonnetworks.com

Telephone: +1 877.292.1701

Fax: 949.266.9273

Europe Headquarters

Email: salesupportemea@addonnetworks.com

Telephone: +44 1285 842070