



Operation Manual

Smart-UPS™ Uninterruptible Power Supply

**500 VA Short-depth Rack-Mount
with Lithium-ion batteries**

120 Vac

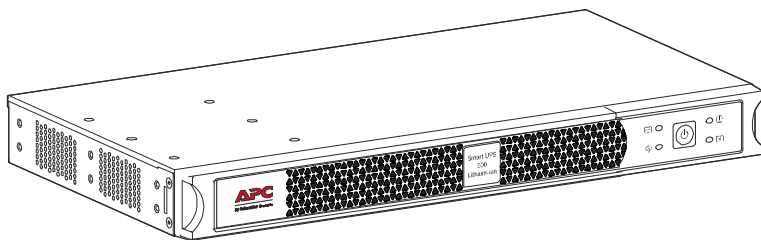

This manual provides critical product, safety and installation information for the SCL500RM1UC and SCL500RM1UNC. The only difference between these two models is in their monitoring and management options. The SCL500RM1UC has the “SmartConnect” port, which allows the product to be monitored remotely. Learn more about the SmartConnect feature on www.smartconnect.apc.com. The SCL500RM1UNC can be managed via traditional methods and APC softwares, it has an embedded network management card, the AP9537SUM.

Important Safety Instructions

SAVE THESE INSTRUCTIONS - This manual contains important instructions that should be followed during installation and maintenance of the UPS and batteries.

Read the instructions carefully and look at the equipment to become familiar with the device before trying to install, operate, service or maintain it. The following special messages may appear throughout this document or on the equipment to warn of potential hazards or to call attention to information that clarifies or simplifies a procedure.



The addition of this symbol either to a “Danger” or “Warning” safety label indicates that an electrical hazard exists which will result in personal injury if the instructions are not followed.



This is the safety alert symbol. It is used to alert you to potential personal injury hazards. Obey all safety messages that follow this symbol to avoid possible injury or death.

DANGER

DANGER indicates a hazardous situation which, if not avoided, **will result in** death or serious injury.

WARNING

WARNING indicates a hazardous situation which, if not avoided, **could result in** death or serious injury.

CAUTION

CAUTION indicates a hazardous situation which, if not avoided, **could result in** minor or moderate injury.

NOTICE

NOTICE is used to address practices not related to physical injury.

Product Handling Guidelines



<18 kg
<40 lb



18-32 kg
40-70 lb



32-55 kg
70-120 lb



>55 kg
>120 lb



Safety and General Information

Inspect the package contents upon receipt. Notify the carrier and dealer if there is any damage.

- Do not work alone under hazardous conditions.
- Adhere to all national and local electrical codes.
- All wiring must be performed by a qualified electrician.
- **Changes and modifications to this unit not expressly approved by APC by Schneider Electric could void the warranty.**
- This equipment is intended for indoor use only.
- Do not operate this unit in direct sunlight, in contact with fluids, or where there is excessive dust or humidity.
- Be sure the air vents on the UPS are not blocked. Allow adequate space for proper ventilation.
- For a UPS with a factory installed power cord, connect the UPS power cable directly to a wall outlet. Do not use surge protectors or extension cords.
- The equipment is heavy. Always practice safe lifting techniques adequate for the weight of the equipment.

Battery safety

WARNING

RISK OF CHEMICAL HAZARD AND EXCESSIVE HEAT

- Recycle the UPS when the UPS battery error is detected at the end of its service life. Power off the UPS and unplug it from the AC input.
- The battery is not user replaceable. Contact APC by Schneider Electric Worldwide Customer Support if there are defects in the product and the product is within warranty.

Failure to follow these instructions can result in death or serious injury.

NOTE: Servicing of user replaceable batteries should be performed or supervised by personnel knowledgeable about batteries and required precautions. In this case batteries are not user replaceable.

- The batteries typically last for 10 years and operate between 0 and 40 °C. Environmental factors impact battery life. Elevated ambient temperatures, poor quality utility power, and frequent short duration discharges will shorten battery life. Batteries should be replaced before end of life. Due to the long life of the batteries, we recommend replacing the unit entirely. For longest battery performance, the ambient temperature should be maintained between 68 and 77 °F (20 and 25 °C).
- This unit uses Lithium Ion batteries. Under normal use and handling, there is no contact with the internal components of the battery.
- Servicing of user replaceable batteries should to be performed or supervised by personnel knowledgeable about batteries and required precautions. In this case, batteries are not user replaceable.
- Disconnect the charging source prior to connecting or disconnecting battery terminals.
- **CAUTION:** Before installing or replacing the batteries, remove conductive jewelry such as chains, wrist watches and rings. High energy through conductive materials could cause severe burns.
- **CAUTION:** Do not dispose of batteries in a fire. The batteries may explode.
- **CAUTION:** Do not open the plastic case of the batteries. Doing so will expose the cell terminals which pose an energy hazard.
- **CAUTION:** Do not open or mutilate the battery or batteries. Released electrolyte is harmful to the skin and eyes. It may be toxic.
- **CAUTION:** Failed batteries can reach temperatures that exceed the burn thresholds for touchable surfaces.
- **CAUTION:** A battery can present a risk of electric shock and burns by high short-circuit current.

Deenergizing safety

The UPS contains internal batteries and may present a shock hazard even when disconnected from the branch circuit (mains). Before installing or servicing the equipment check that the:

- Input circuit breaker is in the **OFF** position.
- Internal UPS batteries are removed.

Electrical safety

- Use tools with insulated handles.
- Do not handle any metallic connector before power has been disconnected.
- For models with a hardwired input, the connection to the branch circuit (mains) must be performed by a qualified electrician.
- 230 V models only: In order to maintain compliance with the EMC regulations, output cords and network cables attached to the UPS must not exceed 10 meters in length.
- The protective earth conductor for the UPS carries the leakage current from the load devices (computer equipment). An insulated ground conductor is to be installed as part of the branch circuit that supplies the UPS. The conductor must have the same size and insulation material as the grounded and ungrounded branch circuit supply conductors. The conductor will typically be green, with or without a yellow stripe.
- Leakage current for a pluggable, Type A UPS may exceed 3.5 mA when a separate ground terminal is used.
- The UPS input ground conductor must be properly bonded to protective earth at the service panel.
- If the UPS input power is supplied by a separately derived system, the ground conductor must be properly bonded at the supply transformer or motor generator set.

General information

- The model and serial numbers are located on a small, rear panel label. For some models, an additional label is located on the chassis under the front bezel.
- Always recycle used batteries.
- Recycle the package materials or save them for reuse.

FCC Class A radio frequency warning

This equipment has been tested and found to comply with the limits for a Class A digital device, pursuant to part 15 of the FCC Rules. These limits are intended to provide reasonable protection against harmful interference when the equipment is operated in a commercial environment. This equipment generates, uses, and can radiate radio frequency energy and, if not installed and used in accordance with the instruction manual, may cause harmful interference to radio communications. Operation of this equipment in a residential area is likely to cause harmful interference in which case the user will be required to correct the interference at his own expense.

Rack-Mounting

1

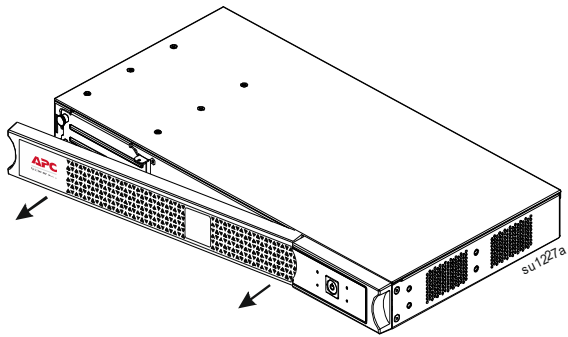

2

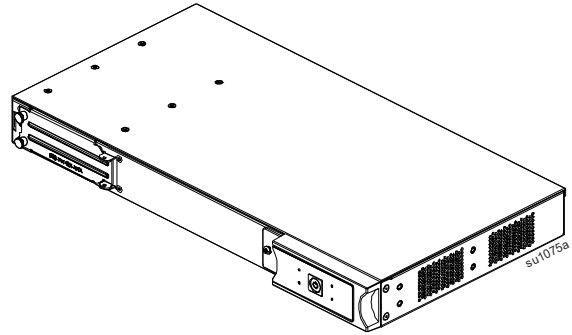

3 **NOTE:** For Two-post rack-mounting, utilize the bracket holes that are offset by 6.25" towards the rear panel of the UPS. 4 Secure clip nuts to the rack, and attach brackets with provided screws.

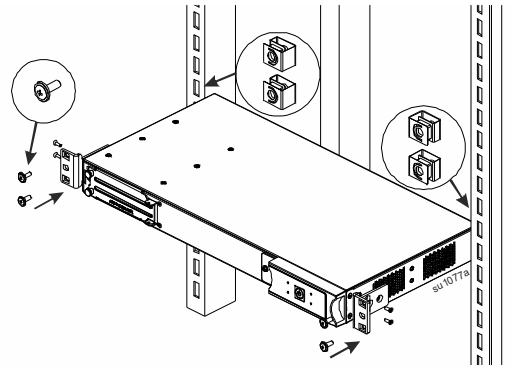
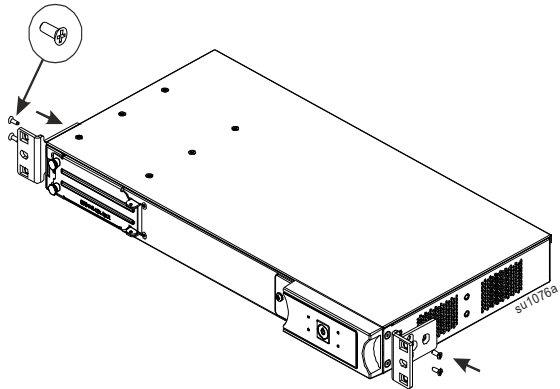

5

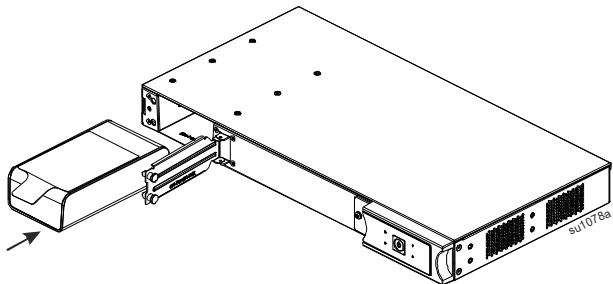

6

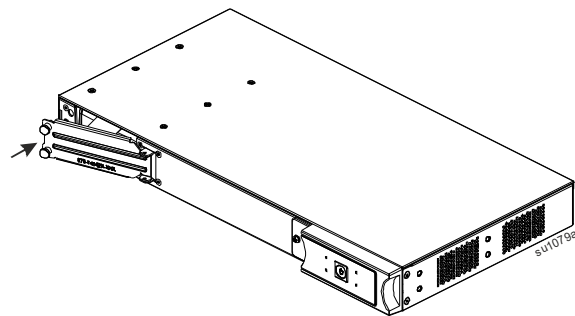

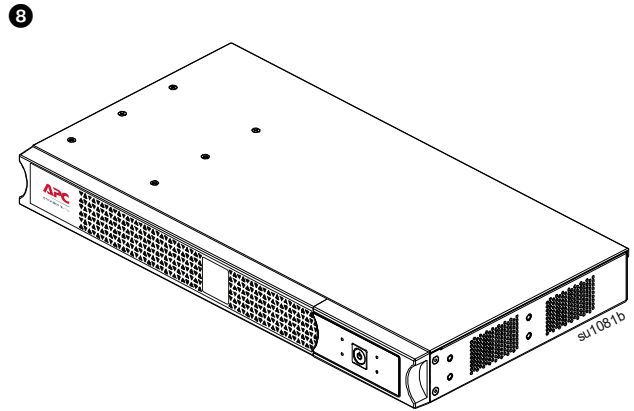
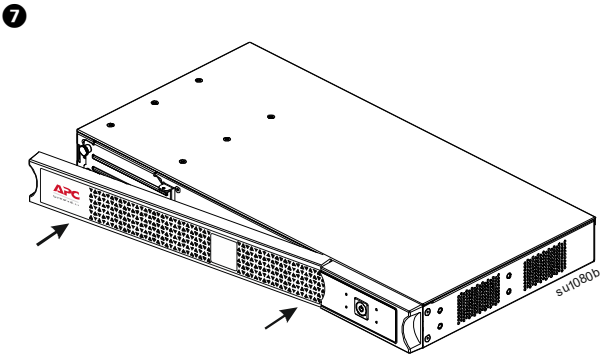

Tower Configuration

NOTE: Connect the battery before tower setup by referring to applicable steps in “*Rack-Mounting*”.

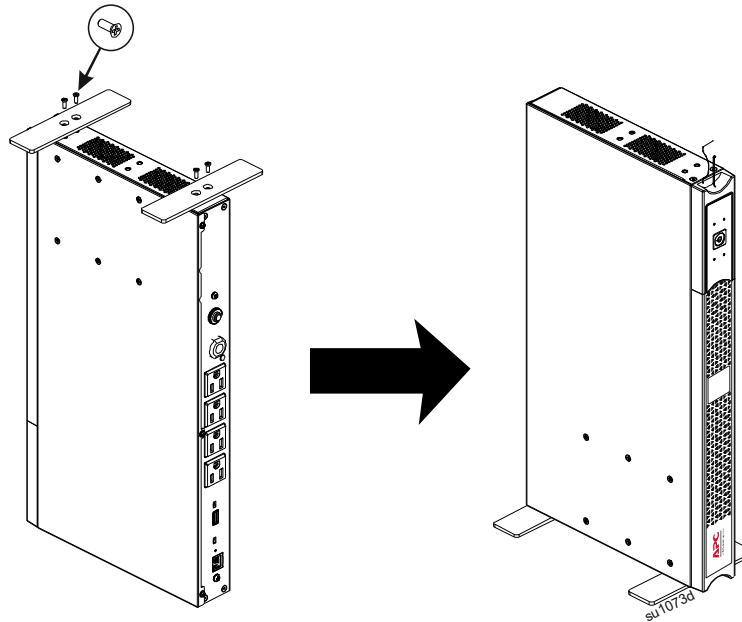

Wall Mounting

CAUTION

RISK OF INJURY OR DAMAGE TO EQUIPMENT

Do not mount the unit on the wall with the bezel facing downwards, or with the display panel at the bottom.

Failure to follow these instructions can result in injury or equipment damage.

NOTE: Connect the battery before mounting by referring to applicable steps in “*Rack-Mounting*”.

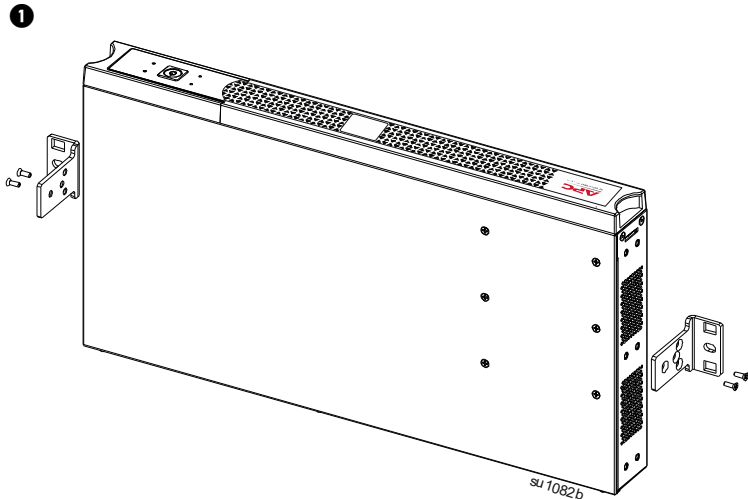

2 NOTE: Whenever possible, attach two screws into wall studs. If stud mounting is not possible, use an expandable wall anchor. Hardware is not included;.25" x 2" lag bolts are recommended. Mount the UPS in either of the displayed positions.

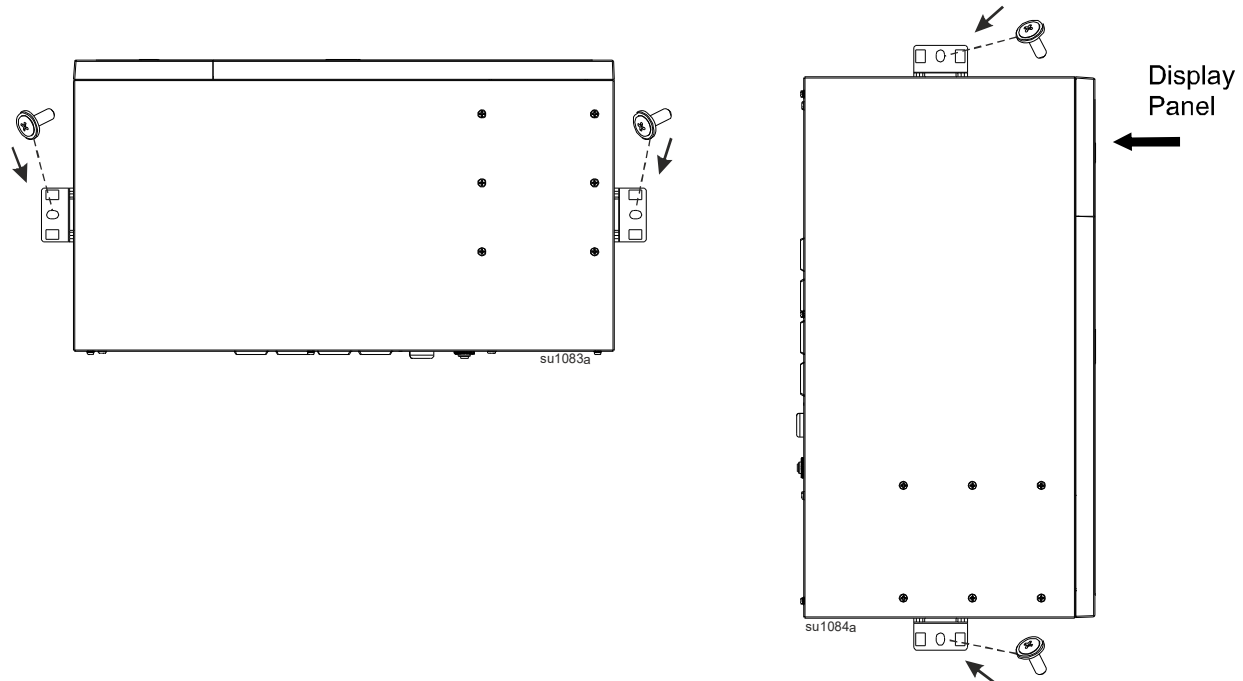

Specifications

For additional specifications, refer to the APC Web site at www.apc.com.

Environmental specifications

Temperature	Operating	0 to 40 °C (32 to 104 °F)
	Storage	-15 to 45 °C (5 to 113 °F)
	Transporting	-20 to 60 °C (-4 to 140 °F)
Maximum Elevation	Storage	25,000 ft. (7,620 m)
	Transporting	50,000 ft. (15,240 m)
Humidity		0% to 95% RH (non-condensing)
International Protection Code		IP20

NOTE: The recommended recharge interval for this UPS is 12 months. The transporting conditions are for 2 weeks maximum.

Product Overview

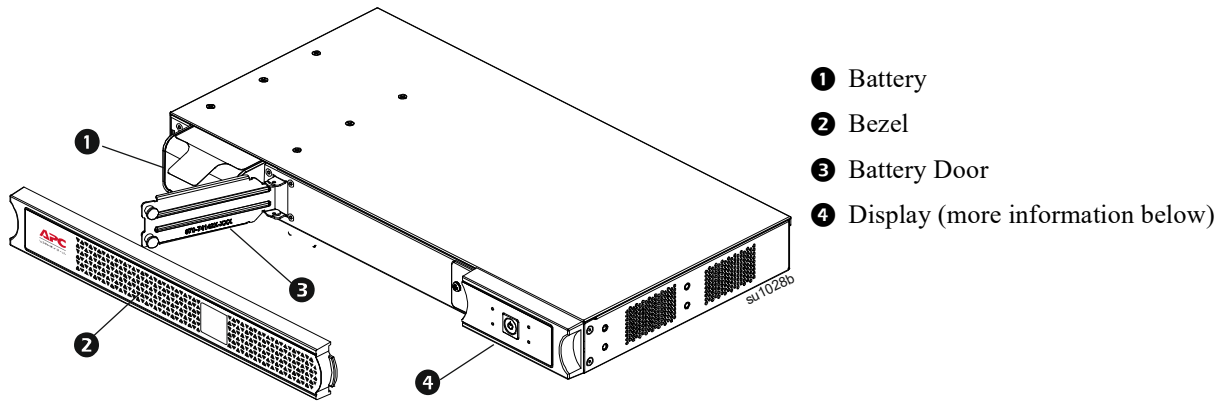

Front panel display features

SCL500RM1UC



- 1 Online / On Battery indicator
- 2 SmartConnect status indicator
- 3 Network status indicator
- 4 Event Detected indicator
- 5 Battery Error indicator

SCL500RM1UNC



Rear panel features

- ❶ SmartConnect Ethernet port (Feature not available in SCL500RM1U)
- ❷ Network port
- ❸ USB port - Use this port connect to a computer for monitoring or gracefully shutting down the UPS using PowerChute software. Refer to “Connect and install management software” on page 10.
- ❹ Chassis ground connection screw
- ❺ Building Wiring Fault Indicators
- ❻ UPS input power cord
- ❼ Circuit breaker
- ❽ Controlled outlet group
- ❾ Outlets
- ❿ SmartConnect Control (this feature is not available in SCL500RM1U)
- ⓫ Modbus TCP Control (this feature is not available in SCL500RM1U)

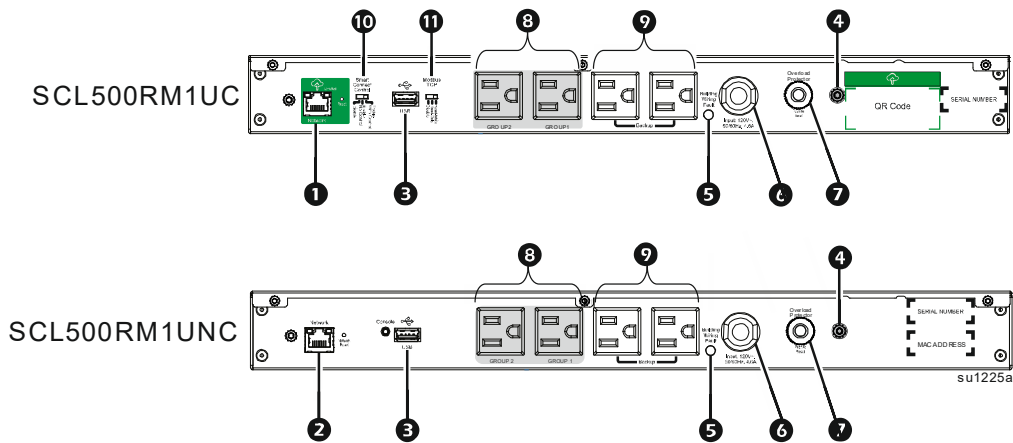

Dimensions and weights

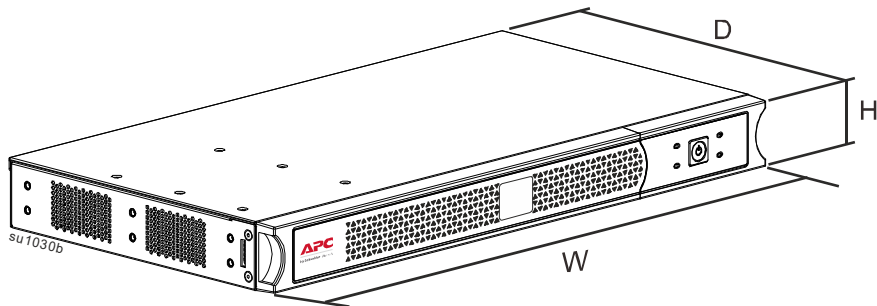

Dimensions (in/mm) H x W x D	Weight (lb / kg)
1.75 x 17 x 9.14 in (44.44 x 431.8 x 232.14 mm)	9.25 / 4.2

Installation

For UPS installation information, refer to the Installation Guide included with the UPS.

Placement

The UPS is intended for IT environments. Avoid placement where there is excessive dust and humidity. Note that temperature in excess of 25 °C may have an adverse effect on battery and UPS life. All vents on the side or rear of the UPS should be free of obstructions.

The UPS is heavy. The UPS should be placed near the bottom of the rack.

Connect to equipment and utilities

NOTE: The UPS will charge to 90% capacity in the first three hours of normal operation.

Do not expect full battery runtime capability during this initial charge period.

CAUTION

RISK OF INJURY OR DAMAGE TO EQUIPMENT

- Adhere to all local and national electrical codes.
- Wiring should be performed by qualified electrician.
- Always connect the UPS to a grounded outlet.

Failure to follow these instructions can result in injury or equipment damage.

1. Connect equipment to the outlets in the rear of the UPS. Some models are equipped with controlled outlet groups. Refer to the “Configuration” section of this manual for further instructions on the use of controlled outlet groups.

2. Connect the SmartConnect Ethernet port  or network port to your nearest network switch using the cable provided.

When connecting to SmartConnect, verify that the SmartConnect Control Switch near the network port is set to either “Enable with Control” or “Enable-No control”.

3. To setup and manage via network port, download the Device IP Configuration Utility from www.apc.com.

4. Connect the UPS input to AC power.

NOTE: Once power is connected the display will be active.

5. Press the main power button  on the UPS display to turn on the UPS output.

NOTE: The On-line LED  will light green when the output is on.

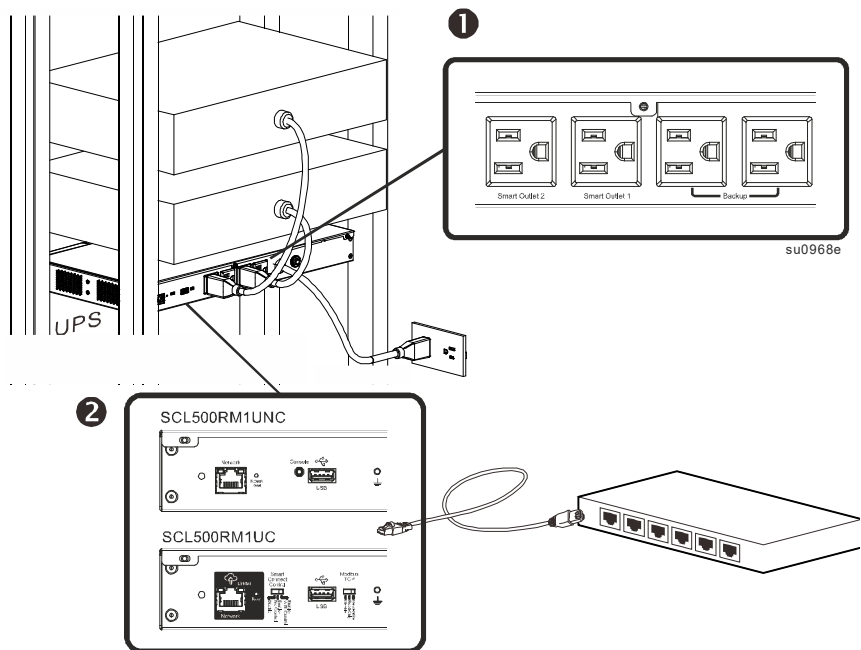

SmartConnect

NOTE: This feature available only in SCL500RM1UC.

SmartConnect Ethernet Port allows you to monitor the health and status of your UPS from any device connected to the Internet.

Availability of features varies by terms of use. Access the terms of use at <https://smartconnect.apc.com>.

Refer to “EcoStructure™ IT SmartConnect” below for details.

EcoStruxure™ IT SmartConnect

NOTE: Applicable for SCL500RM1UC.

The Web Portal allows you to remotely view the status of your UPS, receive automatic notifications about UPS events, and firmware updates. The features may vary with terms of use. Visit <https://smartconnect.apc.com> to learn more.

By connecting this product to the Internet using the SmartConnect Ethernet port, you are agreeing to the APC SmartConnect Terms of Use and Data Privacy Notice, as found at <https://smartconnect.apc.com/terms-and-privacy>.

The Schneider Electric Data Privacy Policy can also be found at <https://smartconnect.apc.com/terms-and-privacy>.

Log onto <https://smartconnect.apc.com> or scan the QR code to begin the registration process. The QR code is located on the rear panel of the UPS.

For instructions on how to register your SmartConnect-compatible UPS, visit <https://smartconnect-support.apc.com>.

Device IP configuration utility

The Device IP Configuration Utility can discover Network Management Cards (NMC 3) that do not have an IP address assigned. Once discovered, you can configure the IP address settings for the cards. You can also search for devices already on the network by entering an IP range to define the search. The Utility scans the IP addresses in the defined range and discovers cards that already have a DHCP-assigned IP address.

For detailed information on the Utility, see the Knowledge Base on the support page of the www.apc.com website and search for FA156064 (the ID of the relevant article).

Once IP address found, access the Web management interface by this IP address. Enter the user name and password to login (by default, use `apc` and `apc` to login as the administrator).

Connect and install management software

NOTE: PCSS is applicable only for SCL500RM1U and SCL500RM1UC



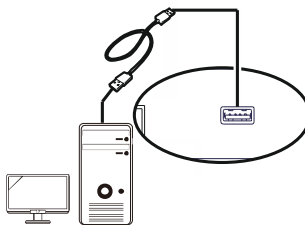



Smart-UPS is provided with PowerChute UPS management software for unattended operating system shutdown, UPS monitoring, UPS control and energy reporting. The following diagram is a representation of a typical server installation.



1	Connect the USB cable from the rear of the UPS to the protected device such as a server.
2	For a server or other device with an operating system, download and install latest version of the PowerChute Serial Shutdown from https://www.apc.com/pcss . PowerChute Serial Shutdown supports graceful shutdown in the event of an extended power outage. NOTE: PowerChute is a 64-bit only application and cannot be installed on a 32-bit operating system.

Operation

Using the display

<p>MAIN ON/OFF</p> 	This button is used to turn the UPS output power on and off.
<p>Quick status LEDs</p> 	The Online indicator illuminates green when UPS output is turned on and operating on AC power.
	The On Battery indicator illuminates orange and the unit will continue to emit a series of short beeps indicating that the UPS is operating on battery power.
	The indicator illuminates red when events occur.
	These indicators illuminate green when SmartConnect connection is okay.
	These indicators illuminate red when SmartConnect connection is cut-off
	These indicators illuminate green or orange when Network connection is okay.
	The Battery Error indicator illuminates red when the UPS battery does not pass self test.

Configuration

General configuration settings

Configuration settings may be changed at any time using the PowerChute software. Configuration settings can also be changed via NMC web interface in SCL500RM1UNC. This table provides a brief description of the general settings, for more detailed information on each of these parameters consult application note 80 at www.apc.com.

Function	Factory Default	Options	Description
High Transfer	136 Vac	130 Vac - 142 Vac	To avoid unnecessary battery usage, set the transfer point higher if the AC voltage is chronically high and the connected equipment is known to work under this condition. The Power Quality setting will automatically change this setting.
Low Transfer	100 Vac	90 Vac - 106 Vac	Set the transfer point lower if the AC voltage is chronically low and the connected equipment can tolerate this condition. This setting may also be adjusted using the power quality setting.
Sensitivity	Normal	<ul style="list-style-type: none"> • Normal • Reduced • Low 	<p>Select the level of sensitivity to power events that the UPS will tolerate.</p> <ul style="list-style-type: none"> • Normal: The UPS will go on battery power more often to provide the cleanest power supply to the connected equipment. • Reduced: The connected equipment is sensitive to voltage fluctuations. • Low: The UPS will tolerate more fluctuations in power and will go on battery power less often. <p>If the connected load is sensitive to power disturbances, set the sensitivity to Normal.</p>
Date of Last Battery Replacement	Date set at factory.		

Function	Factory Default	Options	Description
Audible Alarm	On	<ul style="list-style-type: none"> • On • Off 	Either the UPS will mute all audible alarms if it is set to Off by management software or the UPS will temporarily mute audible alarms by pressing the power button less than 2 seconds while operating on battery power.
Auto Self Test	On start-up and every 14 days since the last test	<ul style="list-style-type: none"> • Never • Start-up only • Frequency of test (every 7 to 14 days) 	The interval at which the UPS will execute a self-test.
Install FW?	Don't Install	<ul style="list-style-type: none"> • Next off (Updates the UPS Firmware next time that the UPS is turned off) • Now (Updates the UPS firmware immediately without interrupting operations) • Don't Install 	Firmware update: this only appears when new firmware is available in the flash memory of the UPS and is ready to be installed
SmartConnect Control Switch	Enable with control	<ul style="list-style-type: none"> • Enable with control • Enable no control • Disable 	This will permit remote configuration changes.

Outlet group configuration settings

The Main Outlet Group and the Controlled Outlet Group can be configured to independently turn off, turn on, shut down, or reboot connected equipment.

- Turn off: Disconnect from power immediately and connect only with a manual command.
- Turn on: Connect to power immediately.
- Shutdown: Disconnect from power and automatically connect when AC power becomes available.
- Reboot: Disconnect from power, wait for a specified amount of time, then connect to power.

In addition, the Main Outlet Group and the Controlled Outlet Group can be configured to do the following:

- Turn on or off in a specified sequence
- Automatically turn off or shut down when various conditions occur

NOTE: If the Main and Controlled Outlet Groups are not configured, all of the outlets on the unit will still provide battery back-up power.

NOTE: The Main Outlet Group must be turned on for the Controlled Outlet Group to turn on.

Function	Factory Default	Options	Description
Name String Outlet Group	Outlet Groups 1 & 2		Edit these names using an external interface, such as the Network Management Card Web interface.
UPS Name String	UPS Outlets		
Turn On Delay	0 sec	Set the value in seconds	The amount of time the UPS or the Outlet Group will wait between receiving the command to turn on and the actual startup.
Turn Off Delay	<ul style="list-style-type: none"> • 0 sec (Main Outlet Group) • 90 sec (Controlled Outlet Groups) 	Set the value in seconds	The amount of time the Outlet Group will wait between receiving the command to turn off and the actual shut down.

Function	Factory Default	Options	Description
Reboot Duration	8 sec	Set the value in seconds	The amount of time that the Outlet Group must remain off before it will restart.
Minimum Return Time	0 sec	Set the value in seconds	The amount of battery runtime that must be available before the Outlet Group will turn on.
Load Shed On Battery	Disabled	<ul style="list-style-type: none"> • Shutdown with Delay • Shutdown immediately • Turn off immediately • Turn off with delay • Disabled 	<p>When the unit switches to battery power, the UPS can disconnect power to the Controlled Outlet Group to save runtime.</p> <p>To configure this delay time, use the LOAD SHED TIME WHEN ON BATTERY setting.</p>
Load Shed Time when On Battery	Disabled	Set the value in seconds	The amount of time the UPS will keep the Outlet Group on when operating on battery.
Load Shed On Runtime	Disabled	<ul style="list-style-type: none"> • Shutdown with delay • Shutdown immediately • Turn off immediately • Turn off with delay • Disabled 	<p>When the battery runtime falls below the specified value, the Outlet Group will turn off.</p> <p>Configure this time using the LOAD SHED RUNTIME REMAINING setting.</p>
Load Shed On Runtime Remaining	Disabled	Set the value in seconds	When the remaining runtime reaches this level, the Outlet Group will turn off.
Load Shed on Overload	Disabled	<ul style="list-style-type: none"> • Disabled • Enabled 	In the event of an overload (greater than 100% output power), the Outlet Group will immediately turn off to conserve power for essential loads. The Outlet Group will only turn on again with a manual command.

Troubleshooting

Problem and Possible Cause	Solution
The UPS will not turn on or there is no output.	
The unit has not been turned on.	Press the ON key once to turn on the UPS.
The UPS is not connected to AC power.	Be sure the power cable is securely connected to the unit and to the AC power supply.
The input circuit breaker has tripped.	Reduce the load on the UPS. Disconnect nonessential equipment and reset the circuit breaker.
The unit shows very low or no input AC voltage.	Contact a qualified electrician to correct wiring issue.
The battery connector plug is not securely connected.	Be sure that all battery connections are secure.
There is an internal UPS error detected.	Do not attempt to use the UPS. Turn off the UPS and unplug it from AC. Contact APC Customer Care Center for assistance.
The unit cannot remotely turn on.	When network cable is disconnected with the UPS turned off and AC power connected the UPS will, after a while, automatically enter power saving mode. Tap the power button to wake up the UPS and enable its remote control feature.
The UPS is operating on battery, while connected to input AC power.	
The input circuit breaker has tripped.	Reduce the load on the UPS. Disconnect nonessential equipment and reset the circuit breaker.
There is very high, very low, or distorted input line voltage.	Move the UPS to a different outlet on a different circuit. Test the input voltage with the AC voltage display. If acceptable to the connected equipment, reduce the UPS sensitivity.
UPS is emitting intermittent beeps.	
The UPS is operating normally.	None. The UPS is helping protect the connected equipment.
UPS does not provide expected backup time.	
The UPS battery is weak due to a recent power outage or is near the end of its service life.	Charge the battery. Batteries require recharging after extended outages and wear out faster when put into service often or when operated at elevated temperatures. If the battery is near the end of its service life, consider replacing the entire UPS even if the Battery Error indicator has not illuminated.
The UPS is experiencing an overload condition.	Check the UPS load display. Unplug unnecessary equipment, such as printers.
Display interface LEDs flash sequentially.	
The UPS has been shut down remotely through software or an optional accessory card.	None. The UPS will restart automatically when AC power is restored.
The Error LED is illuminated. The UPS displays an error message and emits a constant beeping sound.	
Internal UPS error detected.	Do not attempt to use the UPS. Turn the UPS off and contact the Customer Care Center immediately.
The Battery Error icon is illuminated and the UPS beeps for one minute every five hours.	
The battery has a weak charge.	Allow the battery to recharge for at least four hours. Then, perform a self-test. If the problem persists after recharging, replace the entire UPS unit.
The Battery Error icon is flashing and the UPS beeps once every 2 seconds.	
The battery is not properly connected.	Be sure that the battery connector is securely connected.
The UPS displays a site wiring error message.	
Wiring errors detected include missing ground, line-neutral polarity reversal, and overloaded neutral circuit.	If the UPS indicates a site wiring error, have a qualified electrician inspect the building wiring. (Applicable to 120 V units only.)

Limited Factory Warranty

Schneider Electric IT Corporation (SEIT), warrants its products to be free from defects in materials and workmanship for a period of five(5) years from the date of purchase. The SEIT obligation under this warranty is limited to repairing or replacing, at its own sole option, any such defective products. Repair or replacement of a defective product or parts thereof does not extend the original warranty period.

This warranty applies only to the original purchaser who must have properly registered the product within 10 days of purchase. Products may be registered online at warranty.apc.com.

SEIT shall not be liable under the warranty if its testing and examination disclose that the alleged defect in the product does not exist or was caused by end user's or any third person's misuse, negligence, improper installation, testing, operation or use of the product contrary to SEIT's recommendations or specifications. Further, SEIT shall not be liable for defects resulting from: 1) unauthorized attempts to repair or modify the product, 2) incorrect or inadequate electrical voltage or connection, 3) inappropriate on site operation conditions, 4) Acts of God, 5) exposure to the elements, or 6) theft. In no event shall SEIT have any liability under this warranty for any product where the serial number has been altered, defaced, or removed.

EXCEPT AS SET FORTH ABOVE, THERE ARE NO WARRANTIES, EXPRESS OR IMPLIED, BY OPERATION OF LAW OR OTHERWISE, APPLICABLE TO PRODUCTS SOLD, SERVICED OR FURNISHED UNDER THIS AGREEMENT OR IN CONNECTION HERewith.

SEIT DISCLAIMS ALL IMPLIED WARRANTIES OF MERCHANTABILITY, SATISFACTION AND FITNESS FOR A PARTICULAR PURPOSE.

SEIT EXPRESS WARRANTIES WILL NOT BE ENLARGED, DIMINISHED, OR AFFECTED BY AND NO OBLIGATION OR LIABILITY WILL ARISE OUT OF, SEIT'S RENDERING OF TECHNICAL OR OTHER ADVICE OR SERVICE IN CONNECTION WITH THE PRODUCTS.

THE FOREGOING WARRANTIES AND REMEDIES ARE EXCLUSIVE AND IN LIEU OF ALL OTHER WARRANTIES AND REMEDIES. THE WARRANTIES SET FORTH ABOVE CONSTITUTE SEIT'S SOLE LIABILITY AND PURCHASER'S EXCLUSIVE REMEDY FOR ANY BREACH OF SUCH WARRANTIES. SEIT WARRANTIES EXTEND ONLY TO ORIGINAL PURCHASER AND ARE NOT EXTENDED TO ANY THIRD PARTIES.

IN NO EVENT SHALL SEIT, ITS OFFICERS, DIRECTORS, AFFILIATES OR EMPLOYEES BE LIABLE FOR ANY FORM OF INDIRECT, SPECIAL, CONSEQUENTIAL OR PUNITIVE DAMAGES, ARISING OUT OF THE USE, SERVICE OR INSTALLATION OF THE PRODUCTS, WHETHER SUCH DAMAGES ARISE IN CONTRACT OR TORT, IRRESPECTIVE OF FAULT, NEGLIGENCE OR STRICT LIABILITY OR WHETHER SEIT HAS BEEN ADVISED IN ADVANCE OF THE POSSIBILITY OF SUCH DAMAGES. SPECIFICALLY, SEIT IS NOT LIABLE FOR ANY COSTS, SUCH AS LOST PROFITS OR REVENUE, WHETHER DIRECT OR INDIRECT, LOSS OF EQUIPMENT, LOSS OF USE OF EQUIPMENT, LOSS OF SOFTWARE, LOSS OF DATA, COSTS OF SUBSTITUANTS, CLAIMS BY THIRD PARTIES, OR OTHERWISE.

NOTHING IN THIS LIMITED WARRANTY SHALL SEEK TO EXCLUDE OR LIMIT SEIT'S LIABILITY FOR DEATH OR PERSONAL INJURY RESULTING FROM ITS NEGLIGENCE OR ITS FRAUDULENT MISREPRESENTATION OF TO THE EXTENT THAT IT CANNOT BE EXCLUDED OR LIMITED BY APPLICABLE LAW.

To obtain service under warranty you must obtain a Returned Material Authorization (RMA) number from customer support. Customers with warranty claims issues may access the SEIT worldwide customer support network through the SEIT Web site: www.apc.com. Select your country from the country selection drop down menu. Open the Support tab at the top of the web page to obtain information for customer support in your region. Products must be returned with transportation charges prepaid and must be accompanied by a brief description of the problem encountered and proof of date and place of purchase.

Transport the Unit

1. Shut down and disconnect all equipment.
2. Disconnect the unit from utility power.
3. Disconnect all internal and external batteries (if applicable).
4. Follow the shipping instructions outlined in the *Service* section of this manual.

Service

If the unit requires service, do not return it to the dealer. Follow these steps:

1. Review the *Troubleshooting* section of the manual to eliminate common problems.
2. If the problem persists, contact APC By Schneider Electric Customer Support through the APC web site, **www.apc.com**.
 - a. Note the model number and serial number and the date of purchase. The model and serial numbers are located on the rear panel of the unit and are available through the LCD interface on select models.
 - b. Call APC Support and a technician will attempt to solve the problem over the phone. If this is not possible, the technician will issue a Returned Material Authorization Number (RMA#).
 - c. If the unit is under warranty, it will be repaired or replaced at no cost.
 - d. Service procedures and returns may vary internationally. Refer to the APC web site for country specific instructions.
3. Pack the unit properly to avoid damage in transit. Never use foam beads for packaging. Damage sustained in transit is not covered under warranty.
4. Before shipping, always disconnect all battery modules in a UPS or external battery pack.
5. Write the RMA# provided by Customer Support on the outside of the package.
6. Return the unit by insured, prepaid carrier to the address provided by Customer Support.

APC by Schneider Electric Worldwide Customer Support

Customer support for this or any other APC by Schneider Electric product is available at no charge in any of the following ways:

- Visit the APC by Schneider Electric web site to access documents in the APC by Schneider Electric Knowledge Base and to submit customer support requests.
 - **www.apc.com** (Corporate Headquarters)
Connect to localized APC by Schneider Electric web sites for specific countries, each of which provides customer support information.
 - **www.apc.com/support/**
Global support searching APC by Schneider Electric Knowledge Base and using e-support.
- Contact the APC by Schneider Electric Customer Support Center by telephone or e-mail.
 - Local, country specific centers: go to **www.apc.com/support/contact** for contact information.
 - For information on how to obtain local customer support, contact the APC by Schneider Electric representative or other distributor from whom you purchased your APC by Schneider Electric product.



Select models are compliant with California (CEC) Battery Charger regulations. For more information on your specific model go to www.apc.com.

© 2023 APC by Schneider Electric. APC, the APC logo, PowerChute and Smart-UPS are owned by Schneider Electric Industries S.A.S. or their affiliated companies. All other trademarks are property of their respective owners.