



Pro Series

Portable Monitor

**PRO MP161 E2 (3PB7)
PRO MP161 E2U (3PB7)**

Table of Contents

Preparation for use	3
Packing contents	3
Installation of Monitor Stand	4
Overview of Monitor	5
Connecting to be the monitor of various devices	6
OSD setting	7
OSD keys	7
OSD menu	8
Professional	8
Image	9
Input source.....	10
Navi key.....	11
Setting	12
Exit.....	12
Specification	14
Preset display mode	15
Troubleshooting	16
Safety precautions	17
German Rheinland TUV certifications	19
Energy Star certifications	19
Regulatory information	20

Amendment V2.0, 2024/03

Preparation for use

The information for hardware installation programs is provided in this chapter. Before connecting to devices, be careful to fix the devices and use grounding wrist strap to avoid static electricity.

Packaging contents

Monitor	PRO MP161 E2 (3PB7) PRO MP161 E2U (3PB7)
Document	Quick Start Guide
Signal cable	Mini HDMI TM transmission cable
Power cable/signal cable	Type-C transmission cable



Caution

- If the consumer uses a power adapter for charging, he/she should purchase a matching power adapter that has obtained CCC certification and meets the standard.
- If any item is damaged or missing, please contact the seller or local dealer.
- Packaging contents may vary by country.
- The attached power cable is dedicated to this monitor and should not be used with other products.

Adjusting monitor stand



Caution

- Place the monitor on a soft, protected surface to avoid scratching the display panel.
- Do not use any sharp objects on the panel.
- This product has no protective film, so the user does not need to remove it! Any mechanical damage to the product, including removal of the polarizing film, may affect the warranty repair!

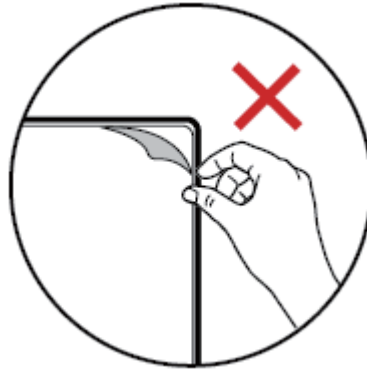

1. Adjust the stand vertically by 180 °.
2. Adjust the stand horizontally by 360 °.
3. Adjust the stand to an appropriate position and place it horizontally on the table.
4. Adjust the stand to an appropriate position and place it vertically on the table.
5. Before placing the monitor, make sure that the stand is properly adjusted to stabilize the monitor.

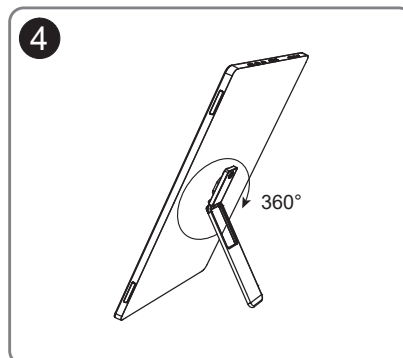
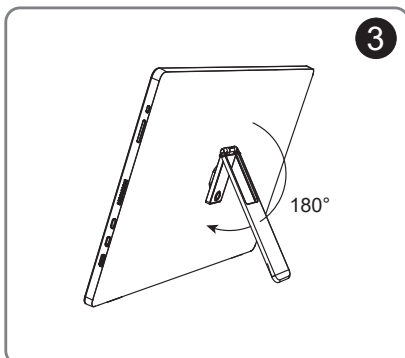
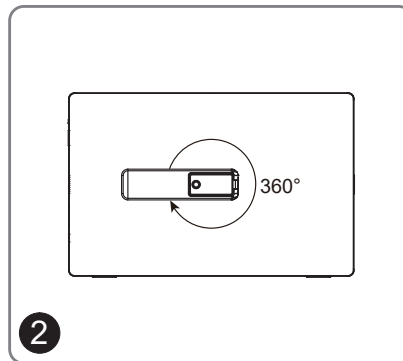
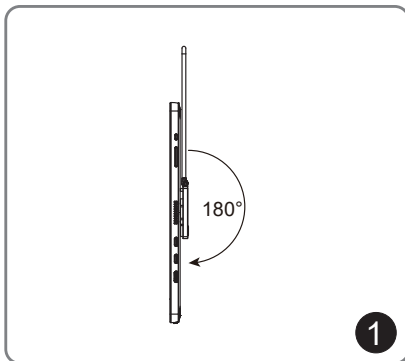

Overview of the monitor

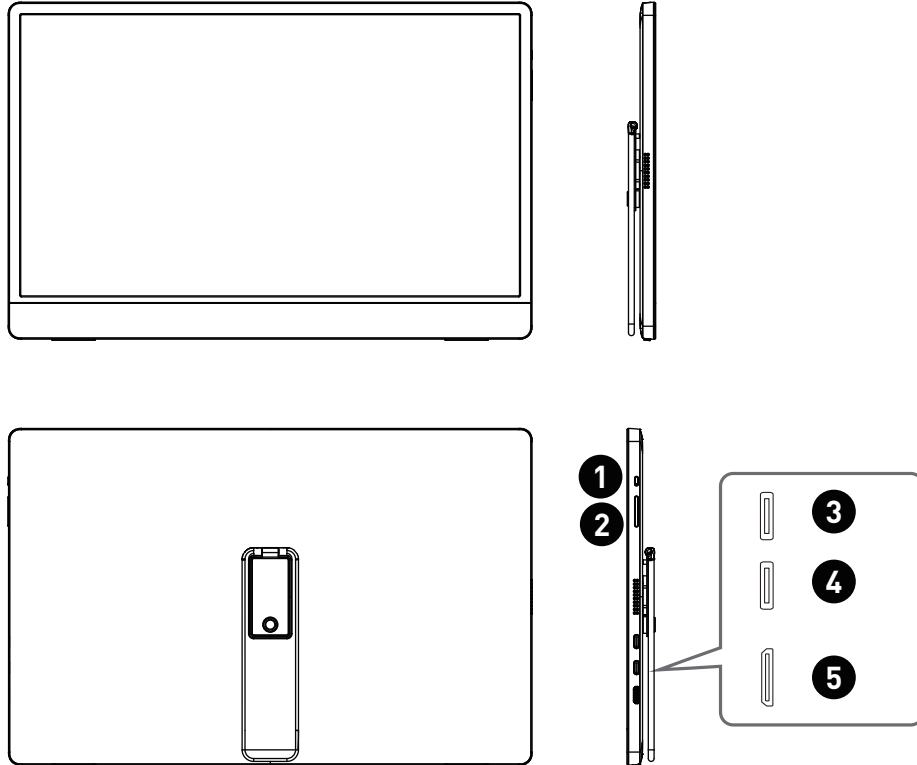

①	Power button
②	Up/down key
③	Type-C2 interface
④	Type-C1 interface
⑤	Mini HDMI interface

Connecting to be the monitor of various devices

1 PC's HDMI as the signal source

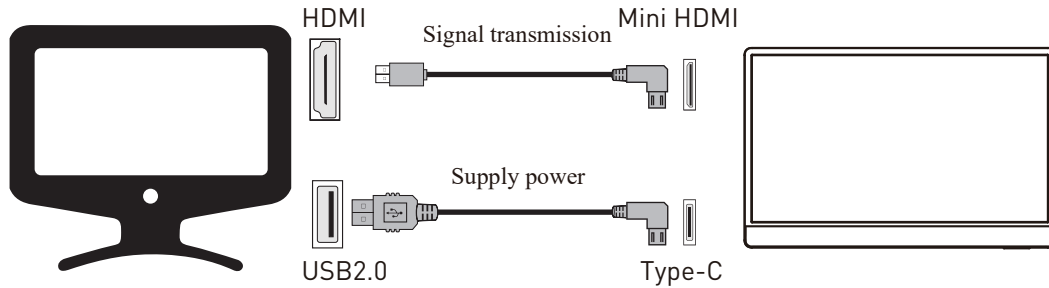

Note: Supplied power shall be larger than 15W

2 Laptop's Type-C as the signal source

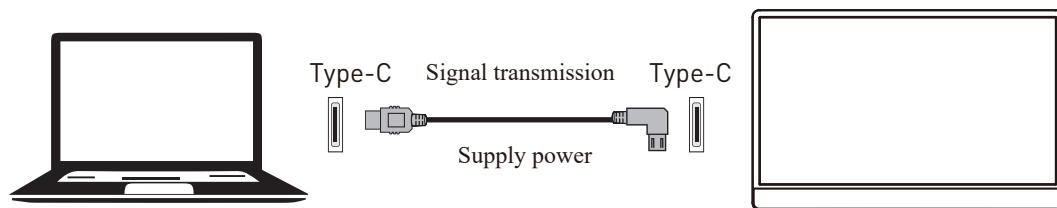

Note: Supplied power shall be larger than 15W

3 Mobile phone's Type-C as the signal source

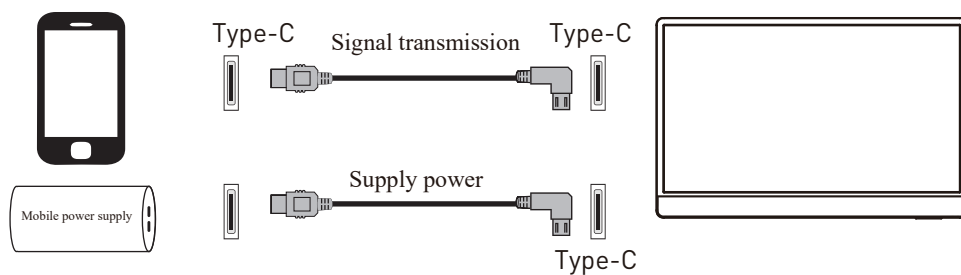

Note: Supplied power shall be larger than 15W

This product is a Type-C power supplying product and it meets LPS requirements.

OSD setting

The basic information for OSD setting is provided in this chapter.



Caution

Any change of the information is not subject to prior notice.

OSD key

A group of OSD keys are provided for this monitor, which help to control on screen display (OSD) menu.

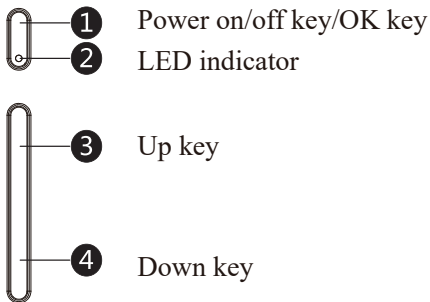
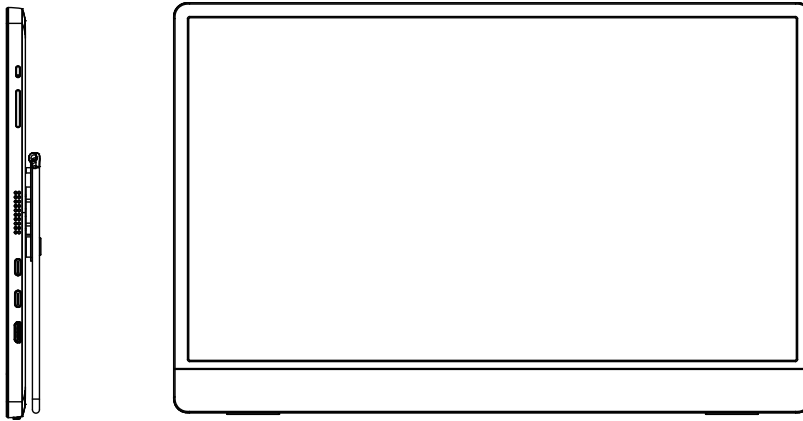





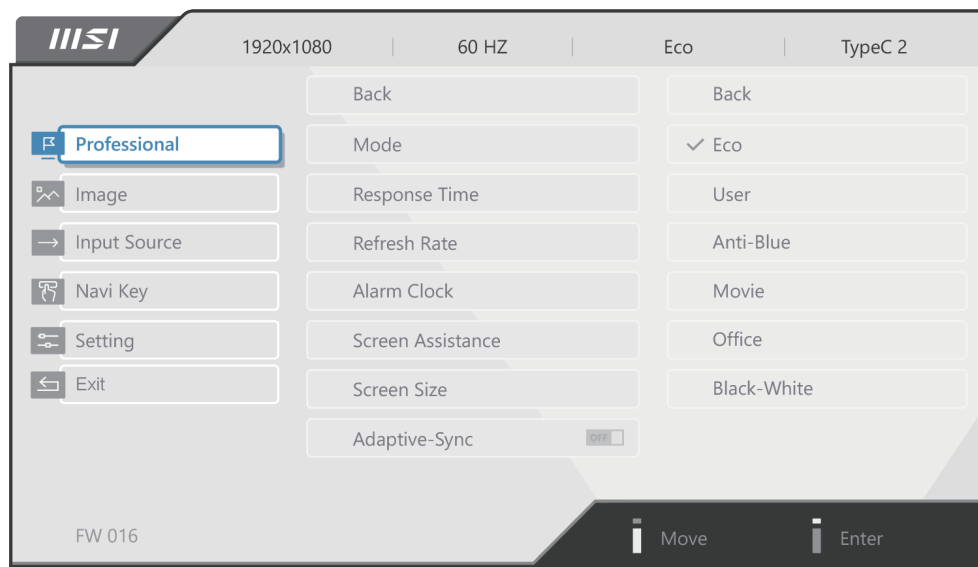



- ① Power on/off key/OK key
 - [2-1 Power off state-hold for 1 second to turn on the power]
 - [2-2 Non-OSD state-hold for 4 second to turn off the power]
 - [2-3 Non-OSD state- press to display OSD]
 - [2-4 OSD state-press to enter the sub-menu]
 - [2-5 OSD state- Hold for 1 second to return, and hold for 4 second again to turn off the power]
- ② LED indicator: [Normally on: normal power-on state; Flickering: Power-saving standby state]
- ③ Up key: [OSD: move upward or increase the progress bar/non-OSD state: set as a hotkey of designated shortcut mode]
- ④ Down key: [OSD: move downward or decrease the progress bar/non-OSD state: set as a hotkey of designated shortcut mode]

OSD menu



Professional

Level-1 menu	Level 2/3 menu	Description	
Back	Back		
Mode	ECO	Use [Up] or [Down] key to select and preview mode and effect. Press OK key to apply your type of mode.	
	USER		
	Anti-Blue light		
	Movie		
	Office		
	Black-white		
Response time	Back	Adjust [Response time].	
	Normal		
	Fast		
	Fastest		
Refresh rate	Back	The default location of [Refresh Rate] is [Left Top]. The [Location] can be adjusted on OSD menu. Press OK key to confirm and apply your location of [Refresh Rate].	
	Location		Left top
			Right top
			Left bottom
			Right bottom

Level-1 menu	Level 2/3 menu		Description
Refresh rate	Off		The monitor will run as per the preset [Refresh Rate] of the screen of the operating system.
	On		
Alarm Clock	Back		<p>After setting time, press OK key to activate the timer.</p> <p>The default location of [Alarm Clock] is [Left Top]. The user can select the [Location] by himself.</p>
	Location	Left Top	
		Right Top	
		Left Bottom	
		Right Bottom	
	Off		
	15:00	00:01~99:59	
	30:00		
45:00			
60:00			
Screen assistance	Back		<p>Select [Off] to disable [Eye-Q Check] function.</p> <p>Select [Amsler Grid] to check central vision state.</p> <p>Select [Astigmatism] to check Astigmatic vision state.</p> <p>Select [Posture correction] to correct the posture.</p>
	Eye-Q check	Off	
		Amsler Grid	
		Astigmatism	
Posture correction			
Crosshair	None		Users can set up "Color Settings" and of the Crosshair.
			
			
			
			
			
			
			
			
			

Level-1 menu	Level 2/3 menu	Description
Screen Size	Back	Adjust [Screen Size]. The default is [Auto].
	Auto	
	4:3	
	16:9	
Adaptive-Sync	Off	Adaptive-Sync can prevent screen tearing.
	On	

Image

Level-1 menu	Level 2/3 menu	Description
Back	Back	Adjust[Brightness] properly according to the surrounding light. After HDCR is enabled, [Brightness] will turn gray and cannot be used.
Brightness	0-100	
Contrast	0-100	Adjust [Contrast] properly to relax your eyes
Sharpness	0-5	[Sharpness] can improve the sharpness and details of images.
Image enhancement	Back	[Image enhancement] can improve the sharpness on the edge of the image.
	Off	
	Weak	
	Medium	
	Strong	
Low Blue light	Off	[Low Blue Light] can protect your eyes against blue light. After it is enabled, [Low Blue Light] can adjust color temperature of the screen to a more yellowish tint. After [Mode] is set as [Anti-Blue Light], [Low Blue Light] will be forced to be enabled.
	On	

Level-1 menu	Level 2/3 menu	Description	
HDCR	Off	HDCR can enhance image quality by improving the contrast of the image. After HDCR is enabled, [Brightness] will turn gray and cannot be used.	
	On		
Color temperature	Back	The default setting of [Color temperature] is [Normal]. Use [Up] or [Down] key to select and preview mode and effect. Press OK key to confirm and apply your type of mode.	
	Cool		
	Normal		
	Warm		
	Customization		R(0-100)
			G(0-100)
	B(0-100)		

Input Source

Level-1 menu	Description	
Back	Select an input source from the list.	
HDMI		
Type-C1		
Type-C2		
	<p>Type-C</p> <p>1) Max transmission rate of data supported: 5Gbps (USB3.1).</p> <p>2) Support Power Delivery input function of different voltage, input: 5V/3A, 9V/3A, 12V/3A, 15V/3A.</p> <p>3) Support image output function, max resolution: 1920*1080@60Hz.</p> <p>Max normal load:</p> <p>Type-C load 5V/0.6A;</p> <p>Type-C load 9V/1A;</p> <p>Type-C load 12V/1A;</p> <p>Type-C load 15V/2.6A;</p>	
Auto Scan	Off	The user can use Navi key to select the input source from the following states: When the monitor is in the power saving mode, [Auto Scan] is set as [Off]; “No signal” message box is displayed on the monitor.
	On	

Navi Key

Level-1 menu	Level 2/3 menu	Description
Back	Back	
Up Down	Back	All the items for Navi key can be adjusted through OSD menu.
	Off	
	Brightness	
	Mode	
	Alarm Clock	
	Input Source	
	Refresh Rate	
	Info. On Screen	
	Audio Volume	

Setting

Level-1 menu	Level 2/3 menu	Description
Back	Back	
Language	Back	<p>The default setting of [Language] is [English]. The user shall press OK key to confirm and apply [Language] setting.</p> <p>[Language] is an independent setting. The user's own language setting will replace the default setting. When the user set [Reset] as [Yes], [Language] will not be changed.</p>
	繁體中文	
	English	
	Français	
	Deutsch	
	Italiano	
	Español	
	한국어	
	日本語	
	Русский	
	Português	
	简体中文	
	ไทย	
	Bahasa Indonesia	
भारतीय हिन्दी		

Setting

Level-1 menu	Level 2/3 menu	Description
Language	Türkçe	<p>The default setting of [Language] is [English].</p> <p>The user shall press OK key to confirm and apply [Language] setting.</p> <p>[Language] is an independent setting. The user's own language setting will replace the default setting. When the user set [Reset] as [Yes], [Language] will not be changed.</p>
	ىفارس	
	Tiếng Việt	
	תִּירָבֶע	
	বাংলা	
	عَرَبِيّ	
	dansk	
	Dutch	
	suomi	
	norsk	
	język polski	
	Svenska	
	čeština	
	magyar	
slovenčina		
Transparency	0~5	The user can adjust [Transparency] in any mode.
OSD time Out	5~30s	The user can adjust [OSD Time Out] in any mode.
Power button	Back	<p>When it is set as [Off], the user can press [System's power button] to turn off the monitor.</p> <p>When it is set as [Standby], the user can press [System's power button] to turn off the panel and backlight.</p>
	Off	
	Standby	
Info. On Screen	Off	<p>The monitor status information will be displayed on the right side of the screen.</p> <p>The user can enable or disable [Info. On Screen]. The default is [Off].</p>
	On	
Audio Volume	0-100	The user can adjust [Audio Volume] in any mode.
Reset	Yes	The user can [Reset] in any mode to restore to original default OSD setting.
	No	

Exit

Exit the menu.

Specifications

Model	PRO MP161 E2 (3PB7) PRO MP161 E2U (3PB7)	
Size	15.6 inch	
Type of panel	IPS	
Resolution	1920*1080@60Hz	
Aspect ratio	16:9	
Brightness (nits)	250 nits (Typical) 210 nits (Minimum)	
Contrast	800:1	
Refresh rate	60Hz	
Response time	4ms (Min.)	
Interface of input source	Mini HDMI interface*1 Type-C interface*2	
I/O	Mini HDMI interface*1 Type-C interface*2	
Viewing angle	170°(H), 170° (V)	
Surface treatment	Anti-glare	
Display color	16.7M (6bits+Hi FRC)	
Power input source	5V-20V--- 3A	
Power output source	5V-20V--- 2.6A	
Dimension (W*H*D)	362.26*232.92*18.8mm	
Weight	0.75kg(N.W.)/1.60kg (G.W.)	
Environment	Operation	Temperature: 0°C -40°C Humidity: 20%-90%, non-condensed Altitude: 0-5000mm.
	Storage	Temperature: -20°C -60°C Humidity: 10%-90%, non-condensed

* Based on CIE1976 test standard.

Preset Display Mode



Caution

Any change of the information is not subject to prior notice.

Standard	Resolution	PRO MP161 E2 (3PB7) PRO MP161 E2U (3PB7)		
		HDMI	TYPE-C1	TYPE-C2
VGA	640*480	@60Hz	V	V
Dos-Mode	720*480	@60Hz	V	V
	720*576	@50Hz	V	V
SVGA	800*600	@56Hz	V	V
		@60Hz	V	V
XVGA	1024*768	@60Hz	V	V
SXVGA	1280*1024	@60Hz	V	V
WXGA+	1440*900	@60Hz	V	V
WSXGA+	1680*1050	@60Hz	V	V
Full HD	1920*1080	@60Hz	V	V

Mode	resolution	PRO MP161 E2 (3PB7) PRO MP161 E2U (3PB7)		
		HDMI	TYPE-C1	TYPE-C2
480P	640*480P	@60Hz	V	V
	720*480P		V	V
720P	1280*720P	@50Hz	V	V
		@60Hz	V	V
1080P	1920*1080P	@50Hz	V	V
		@60Hz	V	V

Troubleshooting

The power LED indicator is not on.

- Press the power button on the monitor again.
- Check if the power cable of the monitor is properly connected.

There's no image.

- Check if the computer and graphics card are installed correctly.
- Check if the computer and monitor are connected to the power socket and powered normally.
- Check if the signal cable of the monitor is correctly connected.
- The computer may be in standby mode. Press any key to start the monitor.

The image is not centered or the size is abnormal.

- Refer to the default display mode and set the computer as the setting fit for the setting of the monitor.

Plug and play does not work.

- Check if the power cable of the monitor is properly connected.
- Check if the signal cable of the monitor is correctly connected.
- Check if your computer and graphics card support Plug and Play.

Icons, fonts and screens are blurry or there are color problems.

- Do not use any extended video transmission cables.
- Adjust brightness and contrast.
- Adjust RGB color or adjust color temperature.
- Check if the signal cable of the monitor is correctly connected.
- Check if the signal cable connector has any bent pins.

The monitor flashes or ripples.

- Adjust the screen update rate in the computer setting to meet the monitor specifications.
- Update the graphics card driver.
- Keep the monitor away from electronic devices that may cause electromagnetic interference (EMI).

Safety precautions

- Be sure to read the safety precautions carefully.
- Pay attention to all the cautions and warnings on the device or in the user guide.
- Only qualified technicians can provide maintenance and repair services.

Power Supply

- Before connecting the device to the power socket, ensure that the power supply voltage is within the safe range and properly adjusted to 100~240V.
- If the power cable has a 3-pin plug, do not close the protective grounding pin of the plug. The computer must be connected to a grounded power socket.
- Confirm that the power distribution system at the installation site should provide a circuit breaker with a rated voltage of 120/240V, 20A (max).
- If you need to stop the device for a long time, be sure to unplug the power cable or turn off the socket switch to achieve zero energy consumption.
- Do not step on the power cable when placing it. Do not place anything on the power cable.
- If this device is equipped with an adapter, use only the AC adapter provided by MSI, which can be used for this device.

Battery

If this device is attached with batteries, take special precautions.

- Incorrect battery replacement has the risk of explosion. Only use the same or equivalent type of product recommended by the manufacturer for replacement.
- Do not throw the battery into the fire or hot oven, or mechanically break or cut the battery to avoid explosion.
- Do not put the battery in an environment with high temperature or extremely low atmospheric pressure to avoid explosion or leakage of flammable liquid or gas.
- Do not ingest batteries. If a coin/button battery is swallowed, it will cause serious internal burns, or even death. Please keep the old and new batteries out of the reach of children.

European union:



Batteries, battery packs and storage batteries should not be disposed of as unclassified household waste. Please follow local laws and regulations to use the public collection system to return, recycle, or dispose of them.

BSMI:



Please recycle the waste battery.

In order to better protect the environment, waste batteries should be collected separately for recycling or special treatment.

California, USA:



Button batteries may contain perchlorate materials and they need special treatment in case of recycling or disposing of.

For more information, please visit: <https://dtsc.ca.gov/perchlorate/>

Environment

- To reduce the injury caused by heat or overheating possibility of the device, do not place the device on a soft and unstable surface or block the ventilation holes of the device.
- Use this device only on a hard, flat and stable surface.
- To prevent the device from tipping over, use an anti-tipping fixture to secure the device to the table, wall or fixed object so that the device is supported properly and it is ensured to be safely in place.
- Keep the device away from any damp and high temperature places to avoid fire and electric shock.
- Do not place the device in a poor environment where the storage temperature is higher than 60 °C or lower than - 20 °C, otherwise the device may be damaged.
- The maximum working temperature is about 40 °C.
- For cleaning the device, be sure to take off the power plug. Use soft cloth to clean the device, do not use industrial chemical detergent. Do not pour any liquid into the opening of the device to avoid damaging the device or causing electric shock.
- Keep the device away from any object with strong magnetism or strong electricity.
- In case of any of the following situations, please contact the service personnel to repair the device:
 - The power cable or plug is damaged.
 - Liquid enters the device.
 - The device gets damp.
 - The device does not work properly or cannot be used normally in accordance with the instructions in the user guide.
 - The device falls off and is damaged.
 - The device is obviously damaged.

German Rheinland TUV certification

German Rheinland TUV Low Blue Light certification

Blue light has been proven to cause eye fatigue and discomfort.

MSI Microstar Technology

now provides the screen that has been awarded the German Rheinland TUV low blue light certification to ensure the comfort and health of user's eyes. Please follow the instructions below to operate the screen so as to reduce the symptoms caused by long exposure to the screen blue light.



- Place the screen 20-28 inches (50-70 cm) from the eyes, with the center point of the screen slightly lower than the line of sight.
- When you need to use the screen for a long time, blink your eyes consciously from time to time will help reduce eye fatigue.
- Rest for 20 minutes every 2 hours.
- At rest, remove your eyes from the screen and gaze at distant objects for at least 20 seconds.
- Stretch moderately during rest to relieve fatigue or pain of your body.
- Activate the optional low blue light function.

German Rheinland TUV Flicker Free (non-flickering) certification

- TÜV Rheinland has tested this product to determine whether it produces visible and invisible flickers to the human eyes and make the user's eyes fatigued.
- TÜV Rheinland has defined the test items and listed the minimum standards with various frequency ranges. The test items are based on internationally applicable standards or the general standards in the industry, and they are even more stringent than these standards.
- This product has been tested in the laboratory according to the above standards.
- The keyword "Flicker Free" confirms that under various brightness settings, this product has no visible and invisible flicker defined in the standard within the frequency range of 0 - 3000 Hz
- When Anti Motion Blur/MPRT is enabled, the monitor will stop supporting the Flicker Free function. (Whether there is the Anti Motion Blur/MPRT function depends on the actual product.)



ENERGY STAR certification

ENERGY STAR is a program implemented by the U.S. Environmental Protection Agency (EPA) and the U.S. Department of Energy (DOE) to improve energy efficiency. The product meets the qualification of ENERGY STAR in the "factory default", and the purpose of energy conservation can be achieved through this setting. Changing factory default picture setting or enabling other features will increase power consumption, which may exceed the limit required to obtain ENERGY STAR rating.

To learn more about ENERGY STAR, visit

<https://www.energystar.gov/>.



Regulatory information

CE compliance

This device has been tested and complies with EU's EMC Directive (2014/30/EU), EU's Low Voltage Directive (2014/35/EU), EU's Energy related Products ErP Directive (2009/125/EC) as well EU's RoHS Directive (2011/65/EU). This product has been tested and meets the IT device coordination standards released in the "EU Official Directive".



FCC - B Radio Frequency Interference Statement

This device has been tested and confirmed to comply with the restriction requirements on Class B digital device in Part 15 of FCC Rules. These restrictions are intended to provide reasonable protection against harmful interference for installation in residential areas. This device may generate, use and transmit radio frequency energy, and if you do not follow the instructions for installation and use, harmful interference may be caused to radio communication. However, there is no guarantee that interference will not occur under specific installation conditions. If this device does cause harmful interference to radio or television reception (it can be determined by turning on or off the power supply of the device), the user can try to take one or more of the following measures to eliminate interference:



- Readjust the direction or position of the receiving antenna.
- Increase the distance between the device and the receiver.
- Use power sockets of different circuits for this device and the receiving device respectively.
- Consult your dealer or an experienced radio/television technician for assistance.

Statement 1

If the change or modification is not confirmed by the responsible party for compliance, the user will lose the qualification to use this device.

Statement 2

In order to meet the radiation limits, shielded interface cable and AC power cable (if any) shall be used.

This device complies with the requirements in Part 15 of the FCC Rules. Its operation meets the following two conditions:

1. This device does not produce harmful interference, and
2. This device must withstand any interference received, including interference that may lead to abnormal operation.

WEEE Statement

The EU has formulated a decree on waste electrical and electronic devices, Directive 2012/19/EU, which expressly stipulates that motor and electronic device products can no longer be disposed of as urban waste, and all related manufacturers of electronic devices shall recycle them after the service life of their products expires.

Chemical information

Follow relevant chemical substance regulations, such as REACH Regulation (EC1907/2006 rules) of the European Union, and MSI provides chemical substance information of products on the following website, please visit:

<https://csr.msi.com/global/index>

Name and content of harmful substances in the product

Name of component	Harmful substance					
	Pb	Hg	Cd	Cr(VI)	PBB	PBDE
PCB component	X	O	O	O	O	O
LCD display screen	X	O	O	O	O	O
Cable/connector	X	O	O	O	O	O
I/O device	X	O	O	O	O	O
Speaker	X	O	O	O	O	O
Metal mechanism	X	O	O	O	O	O
Plastic mechanism/others	O	O	O	O	O	O
Accessories (e.g.: power cable, etc)	X	O	O	O	O	O

This table is made in accordance with SJ/T11364.

O: indicates that the content of harmful substances in such component in all the homogeneous materials is below the limit specified in GB/T26572.

X: indicates that the content of harmful substances in a certain homogeneous material in such component exceeds the limit specified in GB/T26572, but all the components comply with RoHS requirements of EU.

* PCB component: Including PCB and spare parts as its component parts.

** If there's an environment protection service life mark on the battery body, the mark on the battery body shall prevail.

■ The list of toxic and harmful substances or elements mentioned above will be increased or decreased according to the difference of parts of models.

■ Whether there is an environmental protection service life mark on the part body of the product, the mark on the part body shall prevail.

Note for environmental protection service life



The electronic and electrical product contains some harmful substances, which can be safely used within the environmental protection service life, and they shall enter the recycling system after exceeding the environmental protection service life.

Indicative notes to the Regulations on Recycling of Waste Electrical and Electronic Products

In order to better care for and protect the earth, when the user does not need this product or when the service life of the product expires, please observe relevant laws and regulations of the country on recycling of electrical and electronic products, and hand them over to the local plants with national recognized qualifications for recycling and disposal.

Features of green products

- Energy consumption is reduced when the device is used or laid idle.
- Harmful substances are used in a limited way to reduce environmental and health hazards.
- It is easy to be disassembled and recycled.
- Recycling is encouraged to reduce the loss of natural resources.
- The service life of the product is extended through simple product upgrading.
- Solid waste is reduced through recycling strategies.

Environmental policy

- The device and its parts and components are designed to be reused and recycled. Please do not discard them at any time during the service life.
- The user should contact local authorized recycling points to recycle and dispose of the product that has reached its service life.
- For more recycling information, please visit the MSI website and find the nearest dealer.
- The user can also send an email to gpcontdev@msi.com and contact us to learn about the information on disposal, recovery, recycling and disassembly of MSI products.



Warning!

Excessive use of the screen may damage your vision.

Recommendation:

1. Rest for 10 minutes after using the screen for 30 minutes.
2. Infants under 2 years old should not watch the screen, and those over 2 years old should not watch the screen for more than 1 hour a day.

Copyright and Trademark Statement

All rights reserved by Microstar Technology Co., Ltd. MSI logo is registered and owned by MSI Technology Co., Ltd. The trade mark(s) mentioned in this document and all the other trademarks are the assets of their respective owners. We have elaborately prepared this document, but do not guarantee its accuracy absolutely. We will keep improving our our products, so we reserve the right to make changes without prior notice.

Technical support

If the product fails and the user manual does not provide any solution, please contact the seller or local dealer. In addition, please visit the website: <https://www.msi.com/support/> for further guidance.