

MIDDLE ATLANTIC

A brand of  legrand

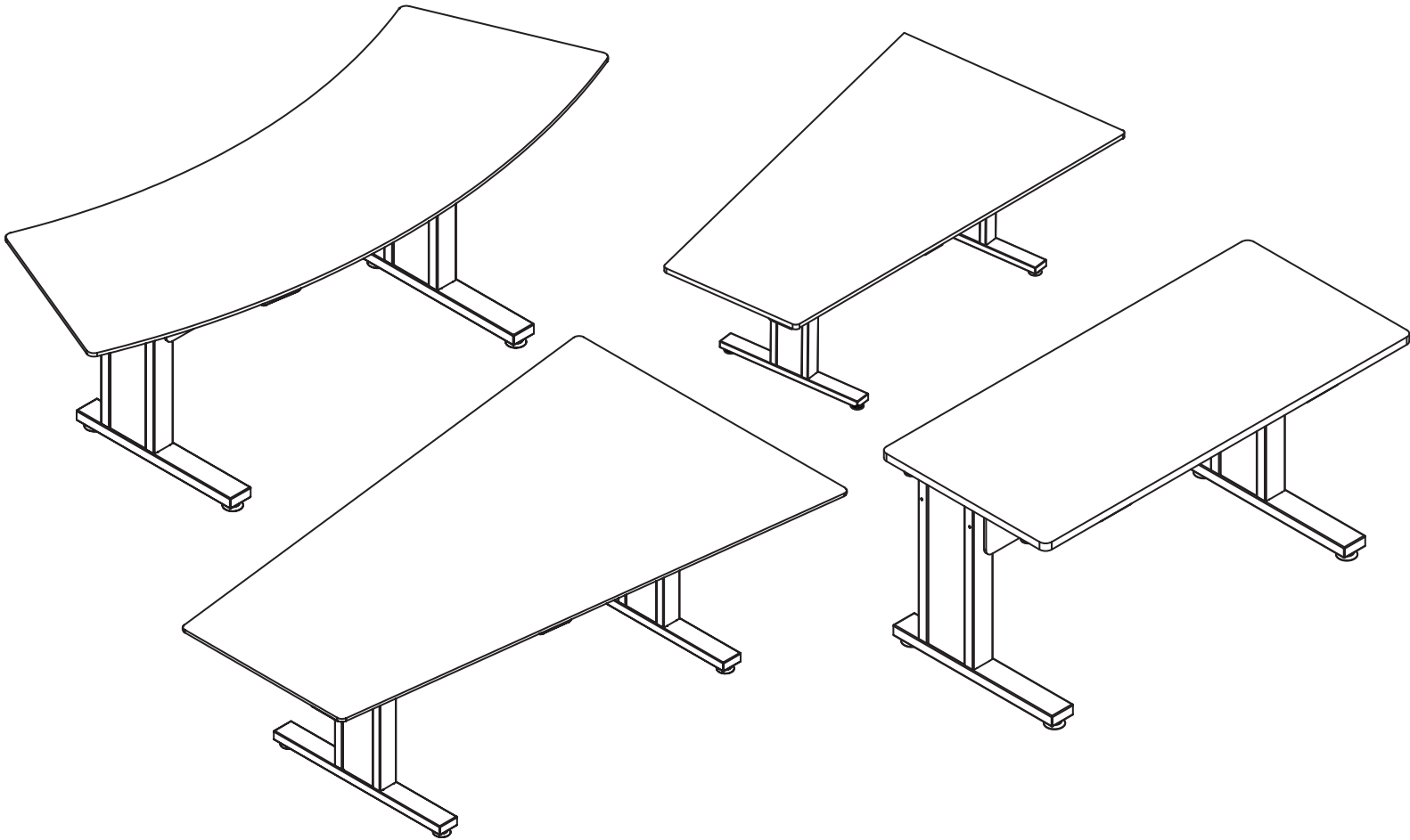

NOTE: The arc, 7' angle, 5' angle, and 5' rectangle table models are shown.

forum[™]
COLLABORATION SUITE

Forum[™] Collaboration Suite Table

Instruction Sheet

100-00086 Rev B



TABLE OF CONTENTS

Important Safety Instructions.....	3 - 5
Supplied Components and Hardware.....	6 - 7
Required Tools.....	7
Introduction.....	7
Preparing the Leg Assemblies.....	8
Attaching the Trough to the Leg Assemblies.....	8
Attaching the Table Top and Modesty Panels.....	9 - 10
Understanding Cable Management.....	10
Joining Tables (If Purchased, Arc and Rectangle Tables Only).....	11
Installing Wiremold ModPower Options to Table (If Purchased).....	11 - 12
Warranty.....	13

IMPORTANT SAFETY INSTRUCTIONS - EN

- Read these instructions.
- Heed all warnings.
- Clean only with dry cloth.
- Keep these instructions.
- Follow all instructions.
- Only use attachments/accessories specified by the manufacturer.



DANGER HAZARDOUS VOLTAGE: The lightning flash with the arrowhead symbol, within an equilateral triangle is intended to alert the user to the presence of uninsulated dangerous voltage within the product's enclosure that may be of sufficient magnitude to constitute a risk of electric shock to persons.



WARNING: A warning alerts you to a situation that could result in serious personal injury or death.



CAUTION: A caution alerts you to a situation that may result in minor personal injury or damage to the product and/or property.

NOTE: A note is used to highlight procedures pertaining to the installation, operation, or maintenance of the product.



WARNING: Failure to read, understand and follow the following information can result in serious personal injury, damage to the equipment or voiding of the warranty. It is the responsibility of the Installer/User to ensure that this product is loaded according to specifications.



WARNING: Middle Atlantic, electrical systems conform to and should be properly grounded in compliance with requirements of the current National Electrical Code or codes administered by local authorities. All electrical products may present a possible shock or fire hazard if improperly installed or used. Electrical products may bear the mark of a Nationally Recognized Testing Laboratory (NRTL) and should be installed in conformance with current local and/or the National Electrical Code.



WARNING: Exceeding the weight ratings listed can result in serious injury or damage to the equipment. It is the responsibility of the Installer/User to ensure the components installed do not surpass the weight ratings as an unstable condition can occur which may cause possible injury or damage.



CAUTION: If there is visible damage on the product, it must not be installed.



CAUTION: Safety measures must be practiced at all times during the assembly of this product. Use proper safety equipment and tools for the assembly procedure to prevent personal injury.



CAUTION: Note that during construction, there must be no possibility of personal injury, for example the squeezing of fingers or arms.



CAUTION: For loading, always put heavier items at the bottom of the bays, not near the top, in order to help prevent the possibility of the furnishing tipping over.



CAUTION: The appliance is not intended for use by young children or infirm persons without supervision.

INSTRUCCIONES DE SEGURIDAD IMPORTANTES - ES

- Lea estas instrucciones.
- Preste atención a todas las advertencias.
- Limpie solamente con un paño seco.
- Guarda estas instrucciones.
- Siga todas las instrucciones
- Utilice únicamente accesorios especificados por el fabricante.



PELIGRO VOLTAJE PELIGROSO: El rayo con el símbolo de punta de flecha dentro de un triángulo equilátero alerta al usuario de la presencia de voltaje peligroso no aislado dentro del producto que puede ser de suficiente magnitud como para constituir un riesgo de descarga eléctrica para las personas.



ADVERTENCIA: Una advertencia lo alerta sobre una situación que podría ocasionar lesiones personales graves o la muerte.



PRECAUCIÓN: Una precaución lo alerta sobre una situación que puede ocasionar lesiones personales menores o daños al producto o a la propiedad.

NOTA: Se utiliza una nota para resaltar los procedimientos relacionados con la instalación, operación o mantenimiento del producto.



ADVERTENCIA: No leer, entender y seguir la siguiente información puede resultar en lesiones personales graves, daños al equipo o anulación de la garantía. Es responsabilidad del instalador/usuario asegurarse de que este producto se carga según las especificaciones.



ADVERTENCIA: Middle Atlantic, los sistemas eléctricos se ajustan a y deben estar correctamente conectados a tierra en cumplimiento con los requisitos del actual Código Eléctrico Nacional o códigos administrados por las autoridades locales. Todos los productos eléctricos pueden presentar un posible riesgo de choque o incendio si se instalan o utilizan incorrectamente. Los productos eléctricos pueden llevar la marca de un Laboratorio de Pruebas Reconocido a Nivel Nacional (NRTL) y deben instalarse de conformidad con la corriente local y/ o el Código Eléctrico Nacional.



PRECAUCIÓN: La superación de los pesos nominales indicados puede provocar lesiones graves o daños en el equipo. Es responsabilidad del instalador/usuario asegurarse de que los componentes instalados no excedan las notas de peso como una condición inestable puede ocurrir que puede causar lesiones o daños.



PRECAUCIÓN: Si hay daños visibles en el producto, no debe ser instalado.



PRECAUCIÓN: Se deben implementar medidas de seguridad en todo momento durante el montaje de este producto. Utilizar equipos y herramientas de seguridad adecuados para los procedimientos de para evitar lesiones.



PRECAUCIÓN: Tenga en cuenta que durante la construcción no debe haber riesgo de lesiones, como por ejemplo aplastar los dedos o los brazos.



PRECAUCIÓN: Para la carga, coloque siempre artículos más pesados en la parte inferior de las bahías, no cerca de la parte superior, para evitar la posibilidad de inclinación de los muebles.



PRECAUCIÓN: El dispositivo no está diseñado para ser utilizado por niños pequeños o personas con discapacidad sin supervisión.

INSTRUCTIONS IMPORTANTES SUR LA SÉCURITÉ - FR

- Lire ces instructions.
- Respectez tous les avertissements.
- Nettoyer uniquement avec un chiffon sec.
- Conservez ces instructions.
- Suivez toutes les instructions.
- N'utilisez que des accessoires spécifiés par le fabricant.



DANGER TENSION DANGEREUSE: Le symbole de la pointe de flèche, dans un triangle équilatéral, est destiné à alerter l'utilisateur sur la présence de tension dangereuse non isolée dans l'enceinte du produit qui peut être d'une ampleur suffisante pour constituer un risque d'électrocution.



AVERTISSEMENT: Un avertissement vous avertit d'une situation pouvant entraîner des blessures graves ou la mort.



ATTENTION: Une attention vous avertit d'une situation pouvant entraîner des blessures mineures ou des dommages au produit et/ou à la propriété.



REMARQUE: Une remarque est utilisée pour mettre en évidence les procédures relatives à l'installation, au fonctionnement ou à l'entretien du produit.



AVERTISSEMENT: Refus de lire, comprendre et suivre la renseignements suivants peut traduire par de graves blessures, des dommages à l'équipement ou invalider la garantie. Il est la responsabilité de l'installateur/utilisateur de s'assurer que ce produit est chargé conformément aux spécifications.



AVERTISSEMENT: Les produits Middle Atlantic, les systèmes électriques sont conformes et doivent être correctement mis à la terre conformément aux exigences du Code national de l'électricité en vigueur ou aux codes administrés par les autorités locales. Tous les produits électriques peuvent présenter un risque d'électrocution ou d'incendie s'ils sont mal installés ou utilisés. Les produits électriques peuvent porter la marque d'un laboratoire d'essais reconnu au niveau national (NRTL) et doivent être installés conformément au code électrique local et/ou national en vigueur.



AVERTISSEMENT: Le dépassement des poids nominaux indiqués peut entraîner des blessures graves ou des dommages à l'équipement. C'est l'responsabilité de l'installateur/utilisateur de s'assurer que les composants installé ne dépassent pas les notes de poids comme un instable condition peut se produire qui peut causer des blessures ou dommages.



ATTENTION: S'il ya des dommages visibles sur le produit, il ne doit pas être installé.



ATTENTION: Des mesures de sécurité doivent être mises en œuvre en tout temps lors de l'assemblage de ce produit. Utiliser un équipement et des outils de sécurité appropriés pour la procédures de afin d'éviter les blessures.



ATTENTION: Notez que pendant la construction, il ne doit pas y avoir de risque de blessure, comme par exemple le écraser des doigts ou des bras.



ATTENTION: Pour le chargement, placez toujours des articles plus lourds au bas des baies, pas près du sommet, afin d'éviter la possibilité de basculement de l'ameublement.



ATTENTION: L'appareil n'est pas destiné à être utilisé par des enfants en bas âge ou des personnes infirmes sans surveillance.

SUPPLIED COMPONENTS AND HARDWARE

If any pieces are missing or damaged, please report it immediately to Technical Support at av.support@legrand.com or (866) 977-3901.

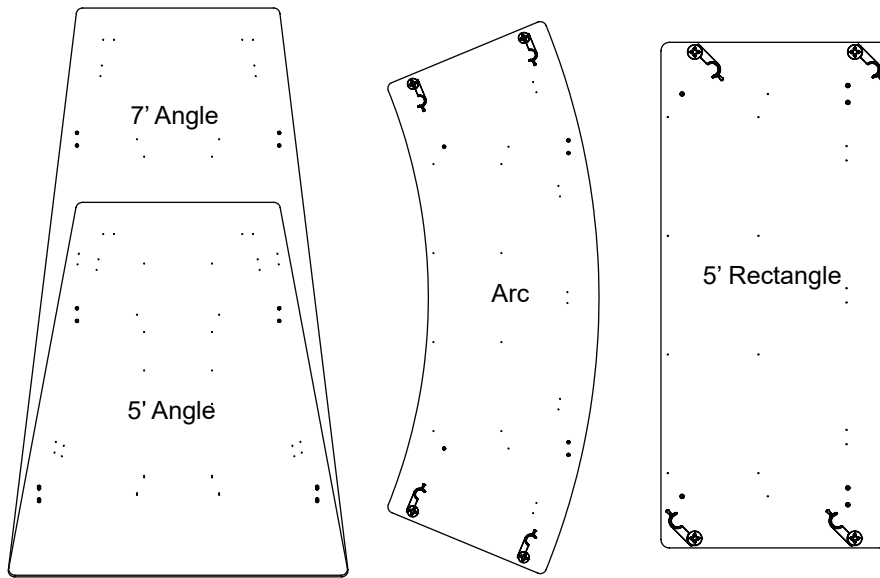
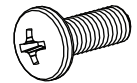

Table Top

NOTE: Available tables include 7' angle, 5' angle, arc, and 5' rectangle models shown.

A



(18x)
10-32 x 1/2" Pan Head
Machine Screw

C

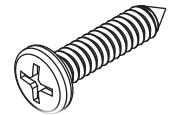

(12x)
#8 x 5/16"
Pan Head Phillips
Sheet Metal Screws

D



(4x)
10-32 Flange Nut

E

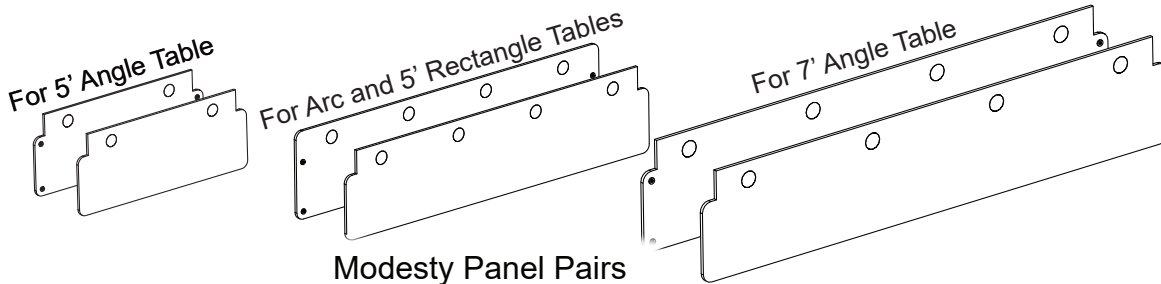

Modesty Panel Pairs
NOTE: Panels come in pairs
for each table top style.

B

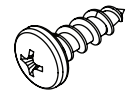

(14x)
#10 x 5/8"
Pan Head Phillips
Flakeboard Screw

F

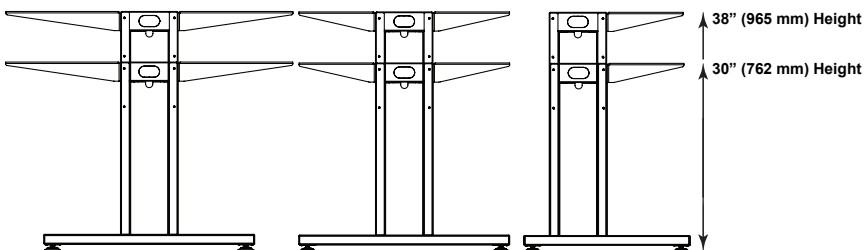
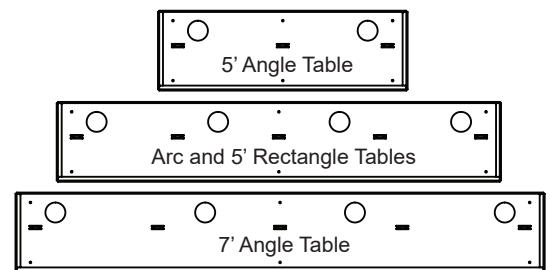

Table Leg Assembly Pair
NOTE: Acoustic felt (PET) panels
pre-assembled on each.

G



Trough

NOTE: Troughs shown for each table top style.

H

WIREMOLD ON SURFACE UNIT OPTIONS (NOT PROVIDED)

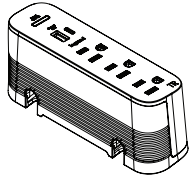

Wiremold On Surface
Primary ModPower Unit (If Purchased)
(Model Number: MDSA10-WH)

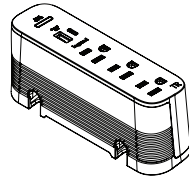

Wiremold On Surface
Middle ModPower Unit (If Purchased)
(Model Number: MDCA3-WH)

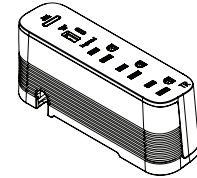

Wiremold On Surface
End ModPower Unit (If Purchased)
(Model Number: MDEA3-WH)

MODPOWER SYSTEM INTERCONNECTING CABLE OPTION (NOT PROVIDED, MODEL NO. MDJ36BK)

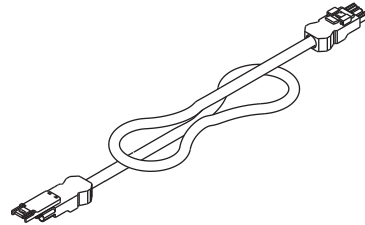

ModPower System
Interconnecting Cable
(Model Number: MDJ36BK)

NOTE:

- To order more hardware, contact support at av.support@legrand.com or (866) 977-3901.
- Additional hardware is included that may not be required for your installation.

REQUIRED TOOLS

- Protective Eyewear
- Socket Wrench
- 3/8" Socket
- Electric drill
- Hammer
- Center Punch
- #2 Phillips Bit
- #2 Phillips Screwdriver



WARNING: Use tools with caution and follow all necessary safety protocols.

ADVERTENCIA: Usar las herramientas con precaucion y seguir los protocolos necesarios de seguridad.

AVERTISSEMENT: Utiliser des outils avec prudence et suivre tous les protocoles de sécurité nécessaires.

INTRODUCTION

NOTE: Please take the time to carefully unpack and inspect all of the products you ordered and save this instruction sheet for future use.

Your Forum™ collaboration suite table configuration may include 5' angle, 7' angle, 5' rectangle, and arc tables.

Use the topics in this instruction sheet in order of appearance and only include applicable sections based on any additional items you may have purchased.

You'll also find content and additional reference covering any optional Interconnecting Cable (MDJ36BK), Wiremold On Surface Primary (MDSA10-WH), Middle (MDCA3-WH), and End (MDEA3-WH) ModPower™ Units you may have purchased.

For more information, refer to the following Forum product page at www.legrandav.com:

https://www.legrandav.com/Products/Technical_Furniture/Collaboration/Forum_Collaboration_Suite

PREPARING THE LEG ASSEMBLIES

NOTE:

- Most cable management and Wiremold Modpower unit installations (if purchased) are typically done after assembling your table. If you prefer doing your cabling and installing Wiremold Modpower during your table assembly, review those topics before you begin. For more information, see "Understanding Cable Management" on page 10 and "Installing Wiremold Modpower Options to Table" on pages 11-12.
 - Table models include 5' angle, 7' angle, arc, and 5' rectangle tables.
 - The step by step assembly example is based on the 5' angle table model, which applies to all tables unless otherwise specified.
1. Use your hand to gently pull at the opening on the top of the inside filler panel from the table leg assembly (only remove the side you are planning to have cables enter/exit your table) and carefully set it aside for re-installation. **(FIGURE A)**

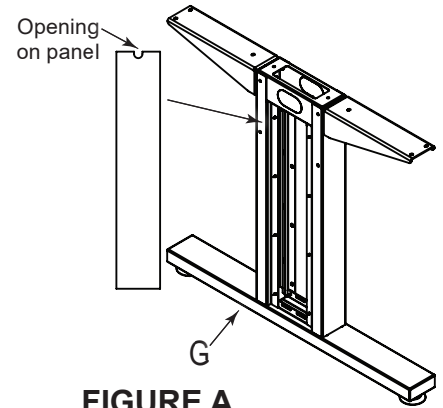

FIGURE A

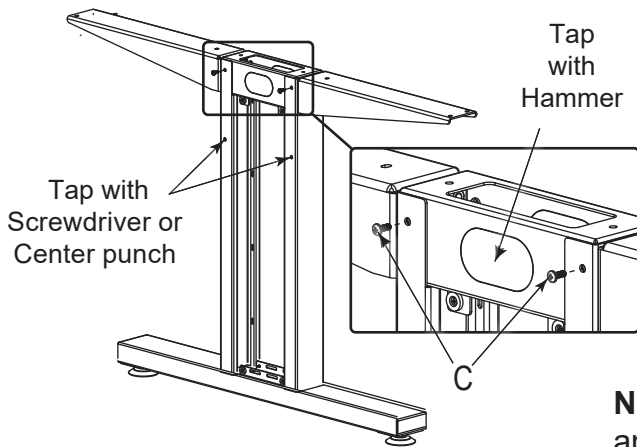

FIGURE B

2. Use a hammer, screwdriver, or center punch to clear the knockouts on the same side/table leg assembly as shown. **(FIGURE B)**

NOTE: Adjust torque on electric drill to lightest setting and only increase as necessary.

3. Use electric drill and Phillips bit to partially attach (2x) 10-32 x 1/2" machine screws (C) to the top inside of both table leg assemblies (G, approximately 1/4" from the surface).

NOTE: Only remove the panel and clear the knockouts from the inside of only one table leg assembly. However, partially attach the (2x) 10-32 x 1/2" machine screws (C) to the top inside of both table leg assemblies.

ATTACHING THE TROUGH TO THE LEG ASSEMBLIES



WARNING: This procedure requires at least one additional person.

PRECAUCION: Este procedimiento require mas de una persona

AVERTISSEMENT: Cette procédure nécessite au moins une personne supplémentaire.

1. Carefully pick up the trough (H) and hook the keyholes over the 10-32 x 1/2" machine screws (C) on the top inside as shown. **(FIGURE C)**

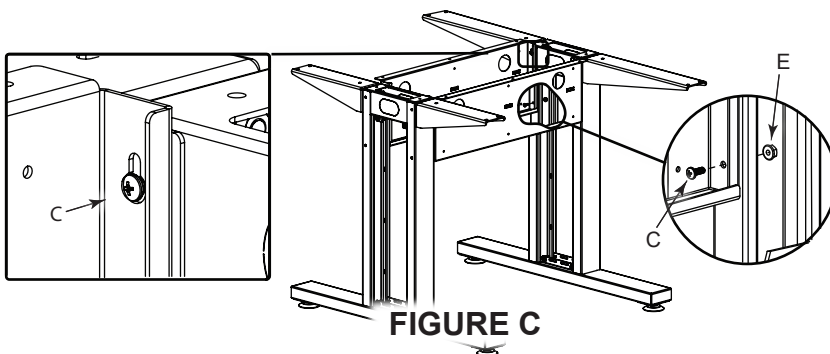

FIGURE C

2. Repeat this step to hook the other end of the trough (H) onto the screws (C) on the second table leg assembly (G).
3. Use a 3/8" socket and screwdriver on (4x) 10-32 flange nuts (E) and (4x) 10-32 x 1/2" machine screws (C) to fully secure the trough to both leg assemblies.

4. Tighten all 8 screws from the previous two steps. Do not overtighten.

ATTACHING THE TABLE TOP AND MODESTY PANELS

NOTE: Underside of a 5' angle table pictured.



WARNING: This procedure requires at least one additional person.
PRECAUCION: Este procedimiento requiere mas de una persona.
AVERTISSEMENT: Cette procédure nécessite au moins une personne supplémentaire.

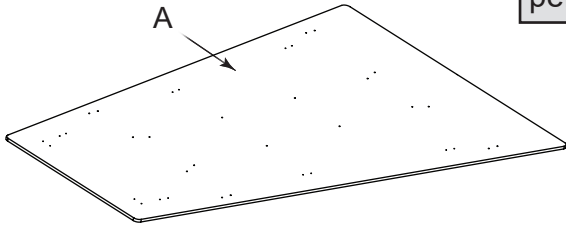

FIGURE D

1. Carefully place your table top (A) upside-down, where the pre-drilled holes are facing up on an appropriate table. (**FIGURE D**)
2. Carefully team lift your table legs and trough assembly and place it upside-down onto the table top.

3. Use electric drill, Phillips bit and 10-32 x 1/2" machine screw (C, amounts and locations based on specific table model purchased) to attach your table legs and trough assembly to the underside of the table top (A) as shown. (**FIGURE E**)

NOTE: Your hardware includes (18x) 10-32 x 1/2" machine screws (C) to provide extra, if needed.

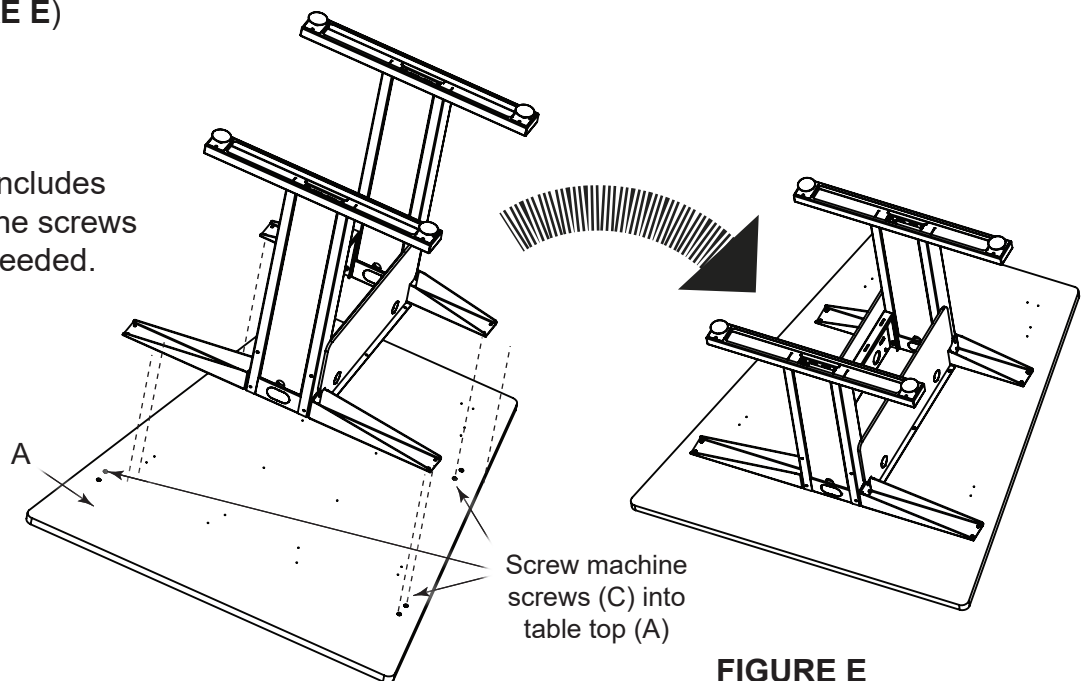

FIGURE E

4. Use electric drill, Phillips bit and 10 x 5/8" flakeboard screws (F, amounts and locations based on specific table model purchased) to attach your trough assembly to the underside of the table top (A) as shown. (**FIGURE F**)

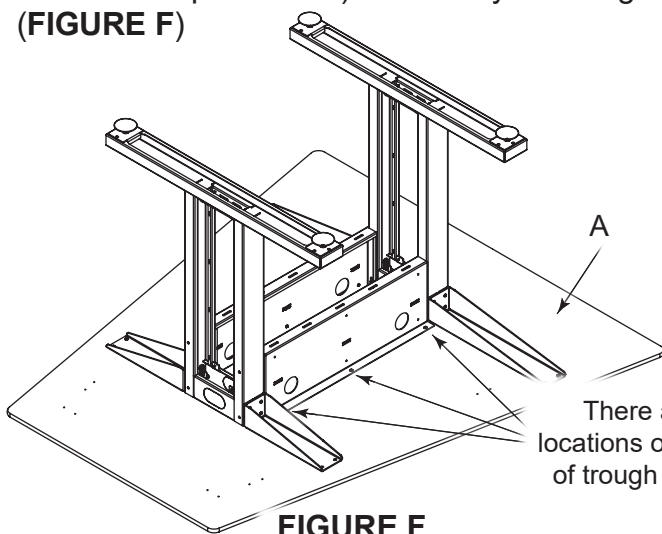

FIGURE F

NOTE:

- Your hardware includes (14x) 10 x 5/8" flakeboard screws (F) to provide extra, if needed.
- Each table top (A) contains different number of screw locations on front and back of trough.

ATTACHING THE TABLE TOP AND MODESTY PANELS (CONTINUED)

4. Use electric drill, Phillips bit, and (12x, 6x per panel) #8 x 5/16" pan head sheet metal screws (D) to attach your modesty panel pair (B) to corresponding sides of your table. The holes are located inside of the trough (H) as shown. **(FIGURE G)**

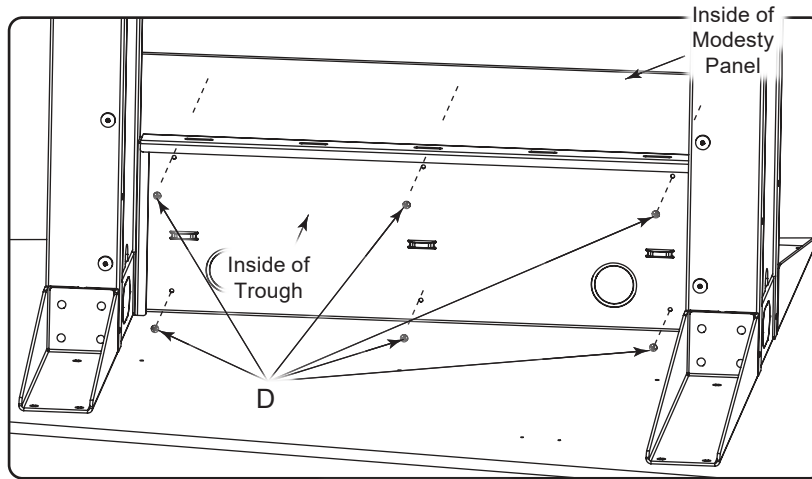

FIGURE G

UNDERSTANDING CABLE MANAGEMENT

1. Carefully team lift the entire table assembly and place it right-side up.

NOTE:

- Table top (A) and panels removed for clarity.
- The image shown of a 5' angle table is provided as a cable management example of lines coming from the floor, up table leg assembly, through knockouts, tied to bridge lances, and out openings. **(FIGURE H)** Your specific installation may differ.

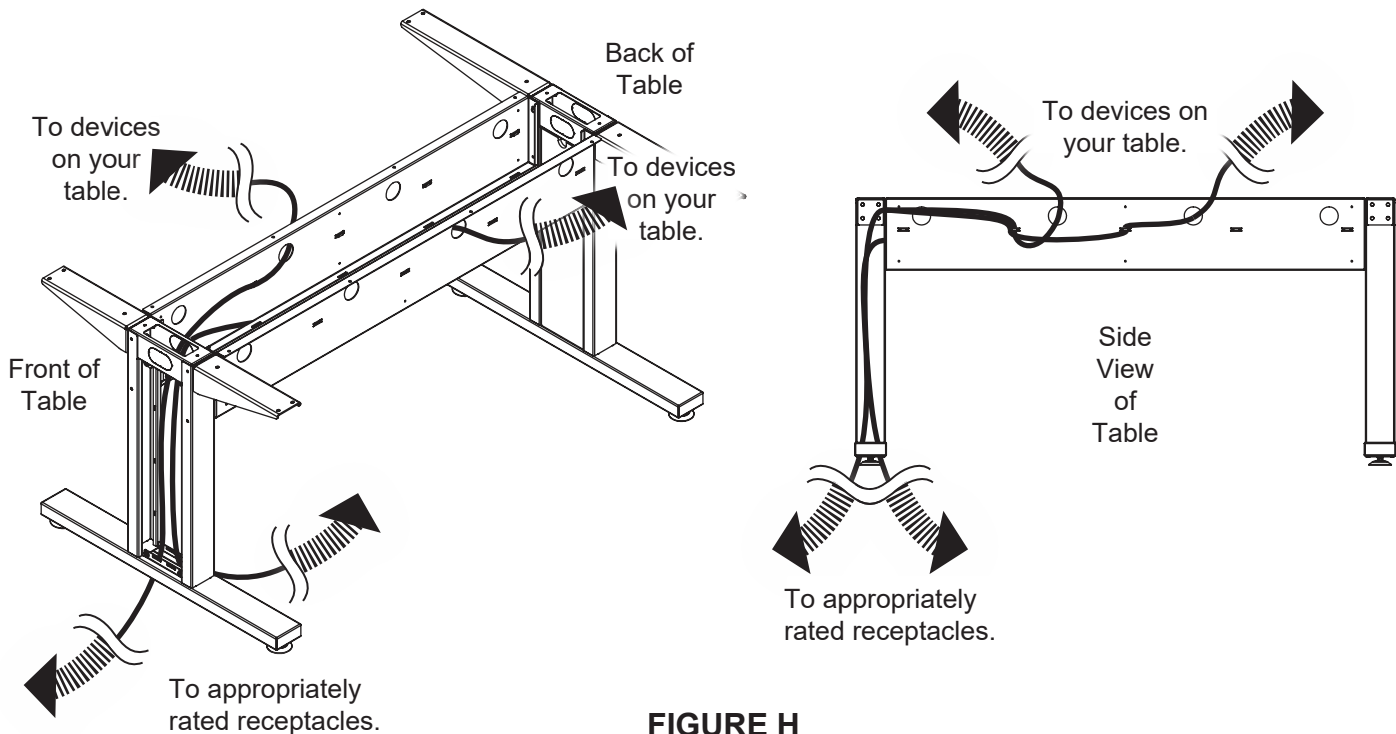

FIGURE H

JOINING TABLES (IF PURCHASED, ARC AND RECTANGLE TABLES ONLY)

WARNING: This procedure requires at least one additional person.
PRECAUCION: Este procedimiento require mas de una persona
AVERTISSEMENT: Cette procédure nécessite au moins une personne supplémentaire.

NOTE: Images in this topic show an arc table coupling. The procedure is applicable to 5' rectangle and arc table models whether coupled as different or identical pairs.

1. Carefully team lift each of your arc tables so the side edges of the table tops (A) aligns as shown. (FIGURE J)

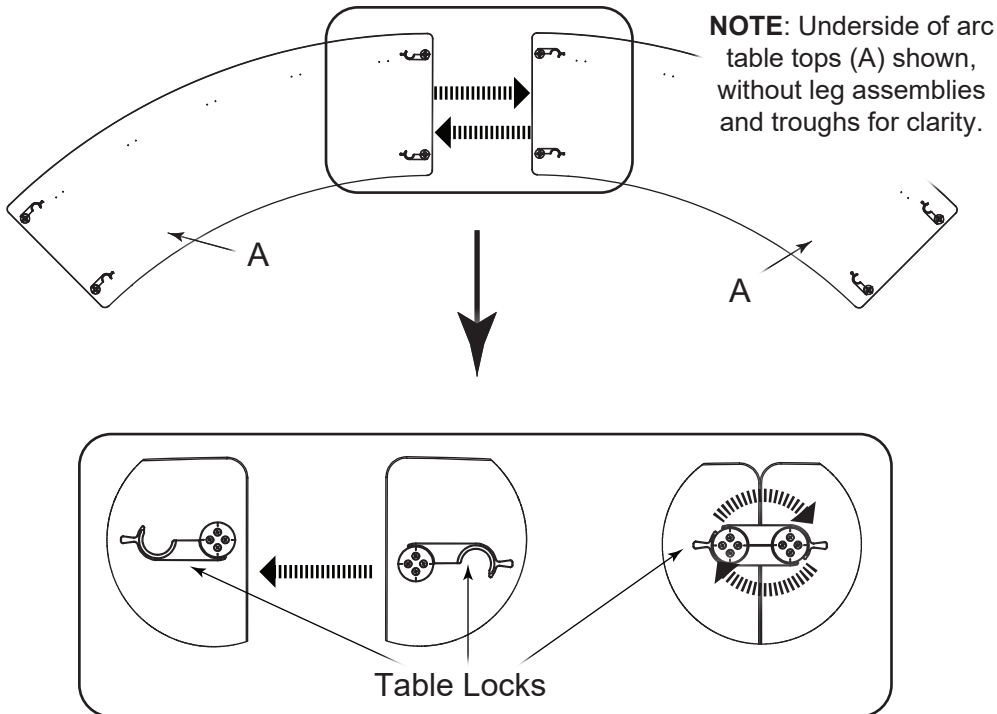

FIGURE J

2. Reach under the table edge and push at the tabs on top of the locks to rotate until each half clasps together and closes securely.
3. Repeat the process for the other lock halves on the same side on the underside of the table tops (A).

INSTALLING WIREMOLD MODPOWER OPTIONS TO TABLE (IF PURCHASED)

NOTE:

- If purchased, a primary ModPower unit is required to run any additional middle and end units.
- A single primary unit may run power to an additional 7 units (for a maximum of 8 total).
- A 5' angle table is shown. (FIGURE K)

Example ModPower Unit Mounting Locations (and Additional Pre-Drilled Screw Locations) on the Underside of the 5' Angle Table Top

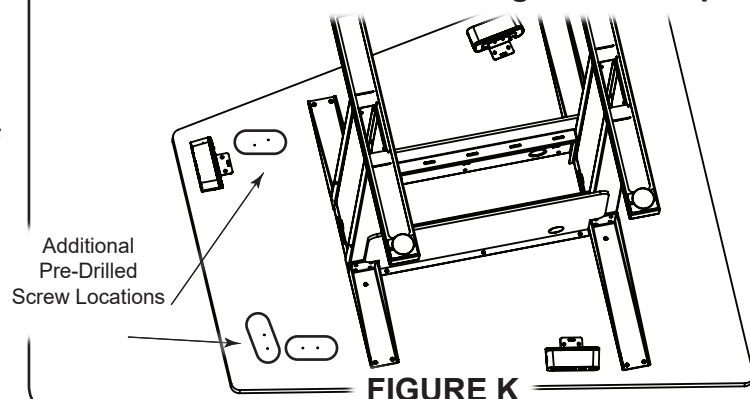

INSTALLING WIREMOLD MODPOWER OPTIONS TO TABLE (CONTINUED)

1. Refer to corresponding On Surface ModPower installation instructions for Primary (MDSA10-WH), Middle (MDCA3-WH), and End (MDEA3-WH) options (not provided) and ModPower Interconnecting Cable (MDJ36BK) options at www.legrandav.com.

The ModPower installation instructions provide details for under-table screw-in mounting and how to correctly wire the units. If purchased, the Interconnecting Cable provides extra cord length when needed.

Example ModPower Unit Mounting Locations (and Additional Pre-Drilled Screw Locations) on the Underside of the Arc Table Top

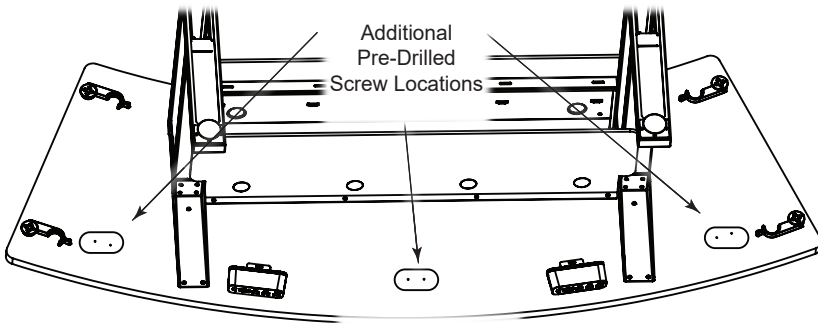

FIGURE L

NOTE: Adjust torque on electric drill to lightest setting and only increase as necessary.

2. While referencing the On Surface ModPower installation instructions, use electric drill, Phillips bit, and the wood screws provided with the unit(s) to attach to the desired pre-drilled hole locations on the bottom of your corresponding table top (A).

3. Connect your unit(s) as specified in the On Surface ModPower installation instructions.

Example ModPower Unit Mounting Locations (and Additional Pre-Drilled Screw Locations) on the Underside of the 5' Rectangle Table Top

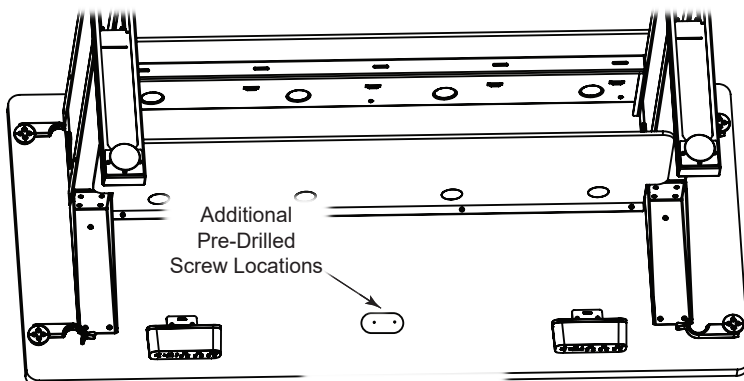

FIGURE M

NOTE:

- Adjacent ModPower units must be mounted less than or equal to 6' (305mm) apart to accommodate the cable length provided.
- A maximum of 6 ModPower units may be connected together.
- The total system length from the plug to the end of the last unit must not exceed 48.5".
- The images shown are provided as examples. Your specific installation may differ.

4. Run the power cable(s) through your table as desired using "Understanding Cable Management" on page 10 and using a ModPower Interconnecting Cable option (not provided) if extra cable length is required for your installation.

NOTE: Only one interconnecting cable may be used between each set of modules

Example ModPower Unit Mounting Locations (and Additional Pre-Drilled Screw Locations) on the Underside of the 7' Angle Table Top

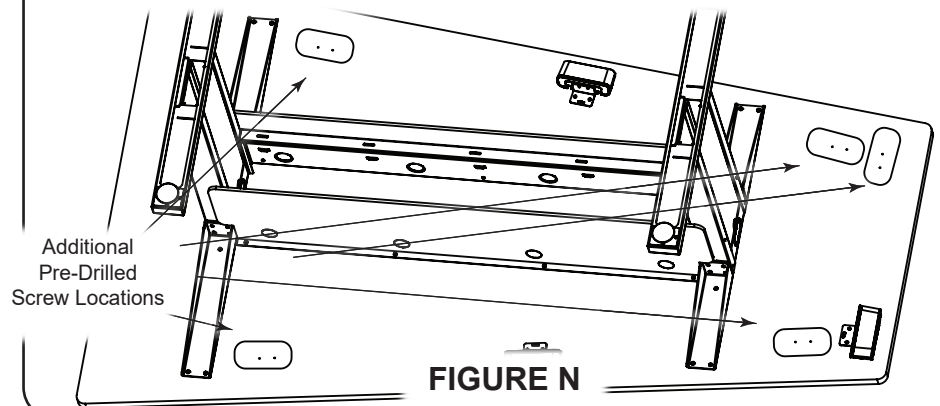

FIGURE N

WARRANTY

For warranty information, refer to www.legrandav.com/policies/warranty_information.

Contacting Corporate Headquarters

P: (866) 977-3901 | F: (877) 894-6918 | www.legrandav.com | av.support@legrand.com

Contacting Middle Atlantic Canada

P: (888) 766-9770 | F: (888) 599-5009 | ca.middleatlantic.com | av.canada.customerservice@legrand.com

Contacting Middle Atlantic Europe, Middle East, and Africa (EMEA) Technical Support

P: +31 495-726-003 | av.emea.middleatlantic.support@legrand.com

United States (US)

Legrand | AV Headquarters
6436 City West Parkway
Eden Prairie, MN, 55344, USA

European Union (EU)

Legrand AV Netherlands
B.V. Franklinstraat 14 6003
DK, Weert, Netherlands

United Kingdom (UK)

Starline Holding Technology Ltd.
(Authorized Representative)
Unit C, Island Rd.
Reading RG2, 0RP- UK

At Legrand AV Inc. we are always listening. Your comments are welcome.

Legrand AV is an ISO 9001 and ISO 14001 Registered Company.

MIDDLE ATLANTIC®

A brand of  **legrand®**