

**SAMSUNG** harman/kardon®

# FULL MANUAL

---

## HW-Q90R

Imagine the possibilities

Thank you for purchasing this Samsung product.

To receive more complete service, please register  
your product at [www.samsung.com/register](http://www.samsung.com/register)









# SAFETY INFORMATION

- The following also applies to the Wireless Subwoofer (PS-WN90) and Surround Speakers (PS-SN90-1, PS-SN90-2).

## SAFETY WARNINGS

TO REDUCE THE RISK OF ELECTRIC SHOCK, DO NOT REMOVE THE COVER (OR BACK). NO USER-SERVICEABLE PARTS ARE INSIDE. REFER SERVICING TO QUALIFIED SERVICE PERSONNEL.

Refer to the table below for an explanation of symbols which may be on your Samsung product.

	<p style="text-align: center;"><b>CAUTION</b> <b>RISK OF ELECTRIC SHOCK.</b> <b>DO NOT OPEN.</b></p>	
	<p>This symbol indicates that high voltage is present inside. It is dangerous to make any kind of contact with any internal part of this product.</p>	
	<p>This symbol indicates that this product comes with important literature concerning operation and maintenance.</p>	
	<p>Class II product : This symbol indicates that a safety connection to electrical earth (ground) is not required. If this symbol is not present on a product with a power cord, the product MUST have a reliable connection to protective earth (ground).</p>	
	<p>AC voltage : Rated voltage marked with this symbol is AC voltage.</p>	
	<p>DC voltage : Rated voltage marked with this symbol is DC voltage.</p>	
	<p>Caution. Consult Instructions for use : This symbol instructs the user to consult the user manual for further safety related information.</p>	

## WARNING

- To reduce the risk of fire or electric shock, do not expose this appliance to rain or moisture.
- To prevent injury, this apparatus must be securely attached to the floor/wall in accordance with the installation instructions.
- This product contains chemicals known to the State of California to cause cancer and birth defects or other reproductive harm.

## CAUTION

- Do not expose this apparatus to dripping or splashing. Do not put objects filled with liquids, such as vases, on the apparatus.
- To turn this apparatus off completely, you must pull the power plug out of the wall socket. Consequently, the power plug must be easily and readily accessible at all times.

## FCC NOTE (for U.S.A):

### FCC Supplier's Declaration of Conformity

#### Responsible Party - U.S. Contact Information:

Samsung Electronics America, Inc.  
85 Challenger Road.  
Ridgefield Park, NJ 07660  
Phone: 1-800-SAMSUNG (726-7864)

#### FCC Compliance Statement :

This device complies with Part 15 of the FCC Rules. Operation is subject to the following two conditions:

- (1) This device may not cause harmful interference, and (2) this device must accept any interference received, including interference that may cause undesired operation.

### **FCC Caution :**

- Any changes or modifications not expressly approved by the party responsible for compliance could void the user's authority to operate this equipment.
- This product satisfies FCC regulations when shielded cables and connectors are used to connect the unit to other equipment. To prevent electromagnetic interference with electric appliances, such as radios and televisions, use shielded cables and connectors for connections.

### **Class B FCC Statement**

This equipment has been tested and found to comply with the limits for a Class B digital device, pursuant to Part 15 of the FCC Rules. These limits are designed to provide reasonable protection against harmful interference in a residential installation. This equipment generates, uses and can radiate radio frequency energy and, if not installed and used in accordance with the instructions, may cause harmful interference to radio communications. However, there is no guarantee that interference will not occur in a particular installation. If this equipment does cause harmful interference to radio or television reception, which can be determined by turning the equipment off and on, the user is encouraged to try to correct the interference by one of the following measures:

- Reorienting or relocating the receiving antenna.
- Increasing the separation between the equipment and receiver.
- Connecting the equipment to an outlet that is on a different circuit than the radio or TV.
- Consulting the dealer or an experienced radio/TV technician for help.

### **FCC Radiation Exposure Statement :**

This equipment complies with FCC radiation exposure limits set forth for an uncontrolled environment. This equipment should be installed and operated so there is at least 8 inches (20 cm) between the radiator and your body. This device and its antenna(s) must not be co-located or operated in conjunction with any other antenna or transmitter.

### **Important Safety Instructions**

Read these operating instructions carefully before using the unit. Follow all the safety instructions listed below. Keep these operating instructions handy for future reference.

1. Read these instructions.
2. Keep these Instructions.
3. Heed all warnings.
4. Follow all instructions.
5. Do not use this apparatus near water.
6. Clean only with dry cloth.
7. Do not block any ventilation openings. Install in accordance with the manufacturer's instructions.
8. Do not install near any heat sources such as radiators, heat registers, stoves, or other apparatus (including amplifiers) that produce heat.
9. Do not defeat the safety purpose of the polarized or grounding-type plug. A polarized plug has two blades with one wider than the other. A grounding type plug has two blades and a third grounding prong. The wide blade or the third prong are provided for your safety. If the provided plug does not fit into your outlet, consult an electrician for replacement of the obsolete outlet.

10. Protect the power cord from being walked on or pinched particularly at plugs, convenience receptacles, and the point where they exit from the apparatus.
11. Only use attachments/accessories specified by the manufacturer.
12. Use only with the cart, stand, tripod, bracket, or table specified by the manufacturer, or sold with the apparatus.  

When a cart is used, use caution when moving the cart/apparatus combination to avoid injury from tip-over.
13. Unplug this apparatus during lightning storms or when unused for long periods of time.
14. Refer all servicing to qualified service personnel. Servicing is required when the apparatus has been damaged in any way, such as power-supply cord or plug is damaged, liquid has been spilled or objects have fallen into the apparatus, the apparatus has been exposed to rain or moisture, does not operate normally, or has been dropped.

## PRECAUTIONS

1. Ensure that the AC power supply in your house complies with the power requirements listed on the identification sticker located on the bottom of your product. Install your product horizontally, on a suitable base (furniture), with enough space around it for ventilation (3~4 inches). Make sure the ventilation slots are not covered. Do not place the unit on amplifiers or other equipment which may become hot. This unit is designed for continuous use.

To fully turn off the unit, disconnect the AC plug from the wall outlet. Unplug the unit if you intend to leave it unused for a long period of time.

2. During thunderstorms, disconnect the AC plug from the wall outlet. Voltage peaks due to lightning could damage the unit.
3. Do not expose the unit to direct sunlight or other heat sources. This could lead to overheating and cause the unit to malfunction.
4. Protect the product from moisture (i.e. vases), and excess heat (e.g. a fireplace) or equipment creating strong magnetic or electric fields. Unplug the power cable from the AC wall socket if the unit malfunctions. Your product is not intended for industrial use. It is for personal use only. Condensation may occur if your product has been stored in cold temperatures. If transporting the unit during the winter, wait approximately 2 hours until the unit has reached room temperature before using.
5. The battery used with this product contains chemicals that are harmful to the environment. Do not dispose of the battery in the general household trash. Do not expose the battery to excess heat, direct sunlight, or fire. Do not short circuit, disassemble, or overheat the battery. Danger of explosion if the battery is replaced incorrectly. Replace only with the same or equivalent type.



# ABOUT THIS MANUAL

The user manual has two parts: this simple paper USER MANUAL and a detailed FULL MANUAL you can download.



## **USER MANUAL**

See this manual for safety instructions, product installation, components, connections, and product specifications.



## **FULL MANUAL**

You can access the FULL MANUAL on Samsung's on-line customer support center by scanning the QR code on the left. To see the manual on your PC or mobile device, download the manual in document format from Samsung's website. (<http://www.samsung.com/support>)













Design, specifications, and App screen are subject to change without prior notice.

# CONTENTS

<b>01</b>	<b>Checking the Components</b>	<b>2</b>
	Inserting Batteries before using the Remote Control (AA batteries X 2)	2
<b>02</b>	<b>Product Overview</b>	<b>3</b>
	Front Panel / Top Panel of the Soundbar	3
	Bottom Panel of the Soundbar	4
<b>03</b>	<b>Connecting the Soundbar</b>	<b>5</b>
	Connecting Electrical Power	5
	Connecting the Soundbar to the Subwoofer and Surround Speakers	6
	– Recommended Speaker Layout	6
	– Automatic connection between the Subwoofer or Surround Speakers and the Soundbar	6
	– Manually connecting the Subwoofer or Surround Speakers if automatic connection fails	7
<b>04</b>	<b>Connecting to your TV</b>	<b>9</b>
	Method 1. Connecting with a Cable	9
	– Connecting a TV using an HDMI Cable	9
	– Connecting using an Optical Cable	10
	Method 2. Connecting Wirelessly	11
	– Connecting a TV via Bluetooth	11
	– Connecting via Wi-Fi	13
<b>05</b>	<b>Connecting an External Device</b>	<b>15</b>
	Connecting using an HDMI Cable (Capable of Dolby Atmos decoding and playback)	15
	Connecting using an HDMI Cable	16
	Connecting using an Optical Cable	17
<b>06</b>	<b>Connecting a Mobile Device</b>	<b>18</b>
	Connecting via Bluetooth	18
	Connecting via Wi-Fi (Wireless Network)	21

<b>07</b>	<b>Connecting an Amazon product</b>	<b>23</b>
	Connect and use with an Amazon product (Amazon Echo)	23
	Use voice commands to control the Soundbar	25
<b>08</b>	<b>Using the Remote Control</b>	<b>26</b>
	How to Use the Remote Control	26
	Adjusting the Soundbar volume with a TV remote control	29
	Using the Hidden Buttons (Buttons with more than one function)	30
	Output specifications for the different sound effect modes	30
<b>09</b>	<b>Installing the Wall Mount</b>	<b>31</b>
	Installation Precautions	31
	Wallmount Components	31
	Installing the Surround Speakers on a Wall (Sold Separately)	33
<b>10</b>	<b>Installing the Soundbar above a TV Stand</b>	<b>34</b>
	Component	34
<b>11</b>	<b>Software Update</b>	<b>34</b>
<b>12</b>	<b>Troubleshooting</b>	<b>35</b>
<b>13</b>	<b>License</b>	<b>36</b>
<b>14</b>	<b>Open Source License Notice</b>	<b>37</b>
<b>15</b>	<b>Important Notes About Service</b>	<b>37</b>
<b>16</b>	<b>Specifications and Guide</b>	<b>38</b>
	Specifications	38

# 01 CHECKING THE COMPONENTS

				
<p align="center"><b>Soundbar Main Unit</b></p>	<p align="center"><b>Remote Control (AH59-02767C) / Batteries</b></p>	<p align="center"><b>Subwoofer</b></p>	<p align="center"><b>Surround Speaker (Left / Right)</b></p>	
<p><b>1</b></p> 	<p><b>2</b></p> 	<p><b>3</b></p> 		
<p><b>Power Cord (Subwoofer) (3903-001117)</b></p>	<p><b>Power Cord (Surround Speaker) (3903-001117)</b></p>	<p><b>Power Cord (Main Unit) (3903-001117)</b></p>	<p><b>HDMI Cable (BN39-01997A)</b></p>	<p><b>Bracket-Wall Mount (AH61-04119A)</b></p>
				
<p align="center"><b>Wall Mount Guide (AH63-04369C)</b></p>	<p align="center"><b>Holder-Screw (AH61-04110A)</b></p>	<p align="center"><b>Screw (6001-001202) (M4 x L10)</b></p>	<p align="center"><b>Rubber-Foot (BN67-00398L)</b></p>	

- For more information about the power supply and power consumption, refer to the label attached to the product. (Label: Bottom of the Soundbar Main Unit)
- The power components are labelled (1, 2, 3). For more information about power connections, see page 5.
- To distinguish the left surround speaker from the right, check the label on the rear of each speaker.
- To purchase additional components or optional cables, contact a Samsung Service Center or Samsung Customer Care.
- The appearance of the accessories may differ slightly from the illustrations above.

## Inserting Batteries before using the Remote Control (AA batteries X 2)

Slide the battery cover in the direction of the arrow until it is completely removed. Insert 2 AA batteries (1.5V) oriented so that their polarity is correct. Slide the battery cover back into position.

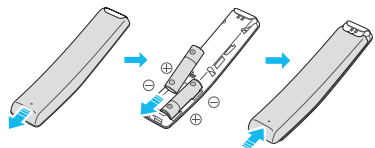

# 02 PRODUCT OVERVIEW

## Front Panel / Top Panel of the Soundbar

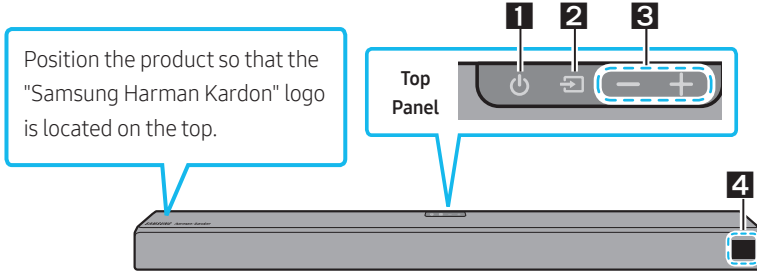

<b>1</b>	<p><b>⏻ (Power) Button</b> Turns the power on and off.</p> <ul style="list-style-type: none"> <li>• <b>Auto Power Down Function</b> The unit turns off automatically in the following situations: <ul style="list-style-type: none"> <li>- In <b>D.IN / HDMI 1 / HDMI 2 / WIFI / BT</b> mode if there is no audio signal for 18 minutes.</li> </ul> </li> </ul>												
<b>2</b>	<p><b>📺 (Source) Button</b> Selects the source input mode.</p> <table border="1" style="width: 100%; border-collapse: collapse;"> <thead> <tr> <th style="text-align: center;">Input mode</th> <th style="text-align: center;">Display</th> </tr> </thead> <tbody> <tr> <td style="text-align: center;">Optical Digital input</td> <td style="text-align: center;">D.IN</td> </tr> <tr> <td style="text-align: center;">ARC (HDMI OUT) input</td> <td style="text-align: center;">D.IN → TV ARC (Auto conversion)</td> </tr> <tr> <td style="text-align: center;">HDMI input</td> <td style="text-align: center;">HDMI 1 / HDMI 2</td> </tr> <tr> <td style="text-align: center;">Wi-Fi mode</td> <td style="text-align: center;">WIFI</td> </tr> <tr> <td style="text-align: center;">BLUETOOTH mode</td> <td style="text-align: center;">BT</td> </tr> </tbody> </table>	Input mode	Display	Optical Digital input	D.IN	ARC (HDMI OUT) input	D.IN → TV ARC (Auto conversion)	HDMI input	HDMI 1 / HDMI 2	Wi-Fi mode	WIFI	BLUETOOTH mode	BT
Input mode	Display												
Optical Digital input	D.IN												
ARC (HDMI OUT) input	D.IN → TV ARC (Auto conversion)												
HDMI input	HDMI 1 / HDMI 2												
Wi-Fi mode	WIFI												
BLUETOOTH mode	BT												
<b>3</b>	<p><b>-/+ (Volume) Button</b> Adjusts the volume.</p> <ul style="list-style-type: none"> <li>• When adjusted, the volume level appears on the Soundbar's front display.</li> </ul>												
<b>4</b>	<p><b>Display</b> Displays the product's status and current mode.</p>												

- When you plug in the AC cord, the power button will begin working in 4 to 6 seconds.
- When you turn on this unit, there will be a 4 to 5 second delay before it produces sound.
- If you want to enjoy sound only from the Soundbar, you must turn off the TV's speakers in the Audio Setup menu of your TV. Refer to the owner's manual supplied with your TV.

# Bottom Panel of the Soundbar

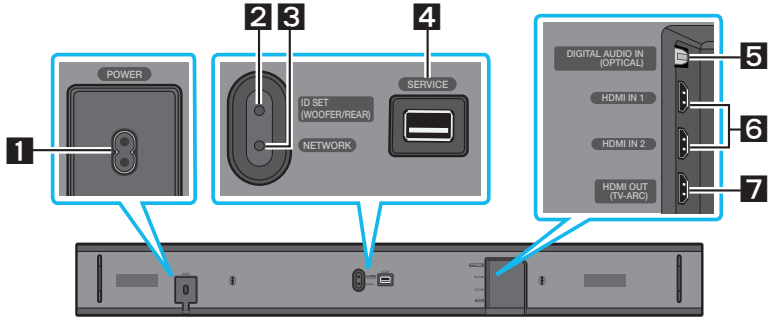

<b>1</b>	<b>POWER</b> Connect the Soundbar's AC power cord.
<b>2</b>	<b>ID SET (WOOFER/REAR)</b> Press to connect the Soundbar to surround speakers and a subwoofer wirelessly. <ul style="list-style-type: none"> <li>Press and hold the <b>Up</b> button on the remote for 5 seconds to complete <b>ID SET</b>.</li> </ul>
<b>3</b>	<b>NETWORK</b> Press to connect to a wireless network (Wi-Fi) via the <b>SmartThings</b> app.
<b>4</b>	<b>SERVICE</b> Connect a USB storage device to upgrade the product's software.
<b>5</b>	<b>DIGITAL AUDIO IN (OPTICAL)</b> Connect to the digital (optical) output of an external device.
<b>6</b>	<b>HDMI IN 1 / HDMI IN 2</b> Inputs digital video and audio signals simultaneously using an HDMI cable. Connect to the HDMI output of an external device.
<b>7</b>	<b>HDMI OUT (TV-ARC)</b> Connect to the HDMI (ARC) jack on a TV.

- When disconnecting the power cord from a wall outlet, pull the plug. Do not pull the cable.
- Do not connect this unit or other components to an AC outlet until all connections between components are complete.

# 03 CONNECTING THE SOUNDBAR

## Connecting Electrical Power

Use the power components (1, 2, 3) to connect the Subwoofer, Surround Speaker, and Soundbar to an electrical outlet in the following order:

- 1 Connect the power cord to the Subwoofer.
- 2 Connect the power cord to the Left and Right Surround Speakers.
- 3 Connect the power cord to the Soundbar.

See the illustrations below.

- For more information about the required electrical power and power consumption, refer to the label attached to the product. (Label: Bottom of the Soundbar Main Unit)

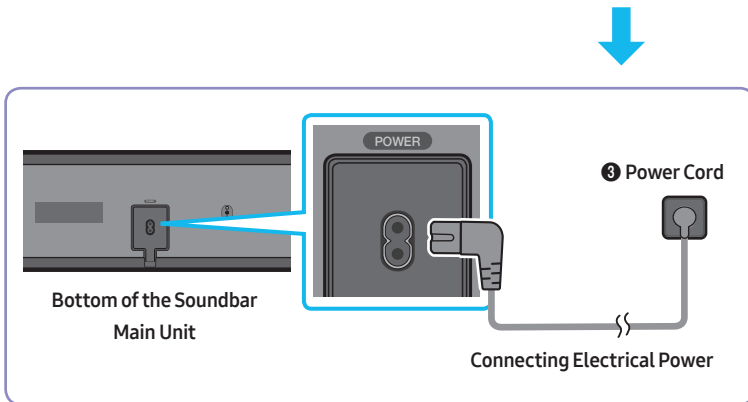
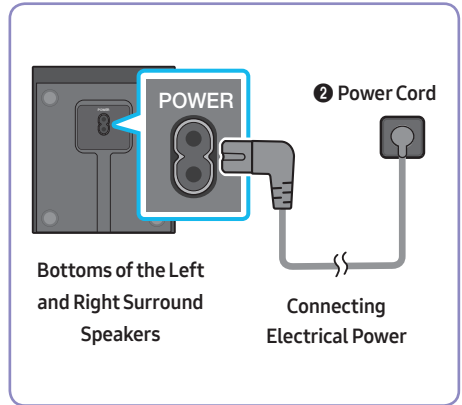
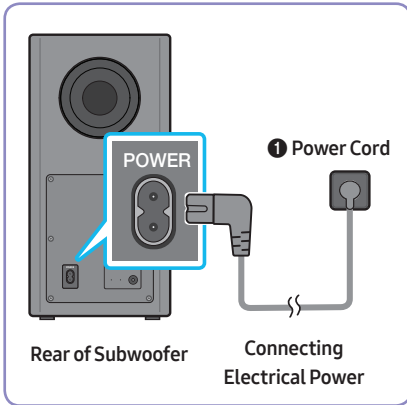

# Connecting the Soundbar to the Subwoofer and Surround Speakers

When the Subwoofer is connected, you can enjoy rich bass sound.

## Recommended Speaker Layout

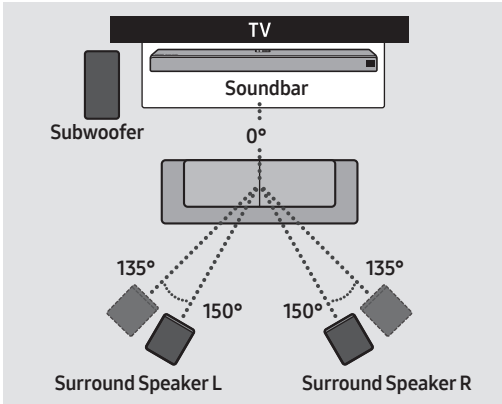

### ⚠ CAUTION

- Wireless receiving antennas are built into the wireless subwoofer and surround speakers. Keep the units away from water and moisture.
- For optimal listening performance, make sure that the areas around the wireless subwoofer and surround speakers locations are clear of any obstructions.

## Automatic connection between the Subwoofer or Surround Speakers and the Soundbar

The subwoofer and/or Surround speakers will connect to the Soundbar automatically if they are plugged in to electrical outlets.

- When auto pairing is complete, the blue indicators at the rear of the Subwoofer or Surround Speaker turn on.

## LED Indicator Lights on the Rear of Subwoofer and Surround Speakers

LED	Status	Description	Resolution
Blue	On	Successfully connected (normal operation)	-
	Blinking	Recovering the connection	Check if the power cable attached to the main Soundbar unit is connected properly or wait about 5 minutes. If blinking persists, try manually connecting the subwoofer. See page 7.
Red	On	Standby (with the Soundbar main unit turned off)	Check if the power cable attached to the main Soundbar unit is connected properly.
		Connection failed	Connect again. See the instructions for manual connection on page 7.
Red and blue	Blinking	Malfunction	See the contact information for the Samsung Service Center in this manual.



## Manually connecting the Subwoofer or Surround Speakers if automatic connection fails

### Before performing the manual connection procedure below:

- Check whether the power cables for the Soundbar and subwoofer or Surround Speakers are connected properly.
- Make sure that the Soundbar is turned on.

1. Press and hold **ID SET** on the rear of the subwoofer and surround speakers for at least 5 seconds.
  - The red indicator at the rear of each speaker turns off and the blue indicator blinks.

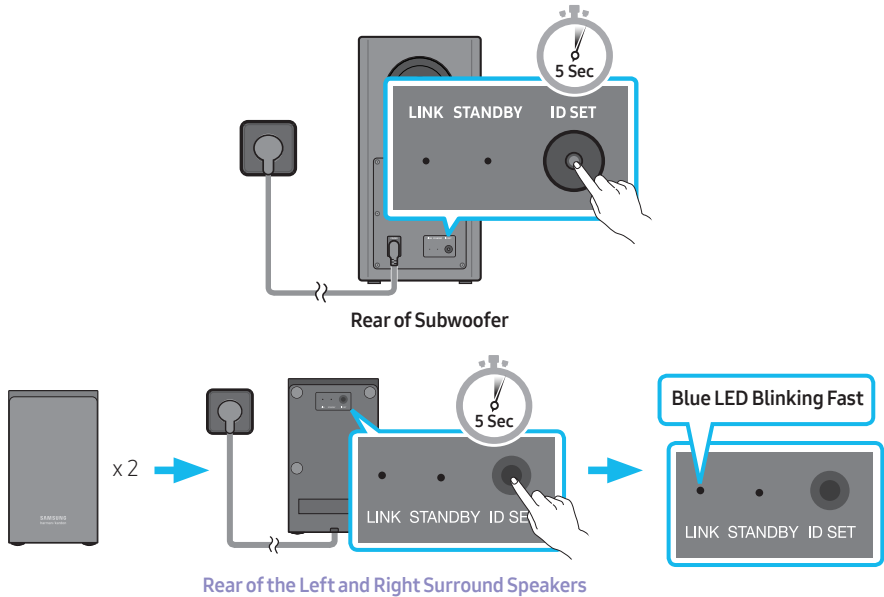

2. Press and hold the **Up** button on the remote control for at least 5 seconds.
  - The **ID SET** message appears on the display of the Soundbar for a moment, and then it disappears.
  - The Soundbar will automatically power on when **ID SET** is complete.

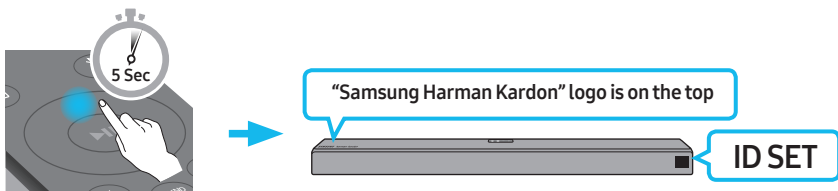

3. Check if the LINK LED is solid blue (connection complete).

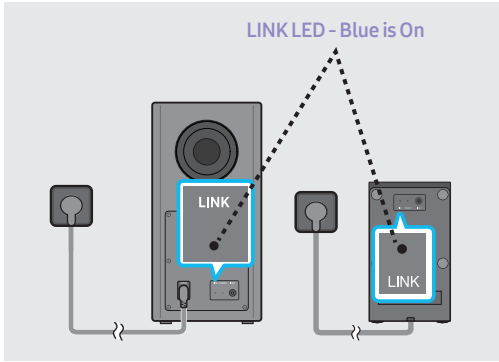

When the connection is successfully established, the blue indicators on the rear of the subwoofer and surround speakers turn on without blinking.

## NOTES

- Do not connect the power cord of this product or your TV to a wall outlet until all connections between components are complete.
- Before moving or installing this product, be sure to turn off the power and disconnect the power cord.
- If the main unit is powered off, the wireless subwoofer will go into stand-by mode and the STANDBY LED on the rear of the sub-woofer will turn red after blinking in blue several times.
- If you use a device that uses the same frequency (5.8GHz) as the Soundbar near the Soundbar, interference may cause some sound interruption.
- The maximum transmission distance of the main unit's wireless signal is about **32.8 ft (10 m)**, but may vary depending on your operating environment. If a steel-concrete or metallic wall is between the main unit and the wireless subwoofer, the system may not operate at all because the wireless signal cannot penetrate metal.

## PRECAUTIONS

- Wireless receiving antennas are built into the wireless subwoofer. Keep the unit away from water and moisture.
- For optimal listening performance, make sure that the area around the wireless subwoofer and surround speakers location is clear of any obstructions.

# 04 CONNECTING TO YOUR TV

Hear TV sound from your Soundbar through wired or wireless connections.

- When the Soundbar is connected to selected Samsung TVs, the Soundbar can be controlled using the TV's remote control.
  - This feature is available on 2017 and later Samsung Smart TVs that support Bluetooth when the Soundbar is connected to the TV using an optical cable.
  - This function also allows you to use the TV menu to adjust the sound field and various settings as well as the volume and mute.

## Method 1. Connecting with a Cable

When the audio in a broadcast is encoded in Dolby Digital and the “Digital Output Audio Format” on your TV is set to PCM, we recommend that you change the setting to Dolby Digital. When the setting on the TV is changed, you will experience better sound quality. (The TV menu may use different words for Dolby Digital and PCM depending on the TV manufacturer.)

### Connecting a TV using an HDMI Cable

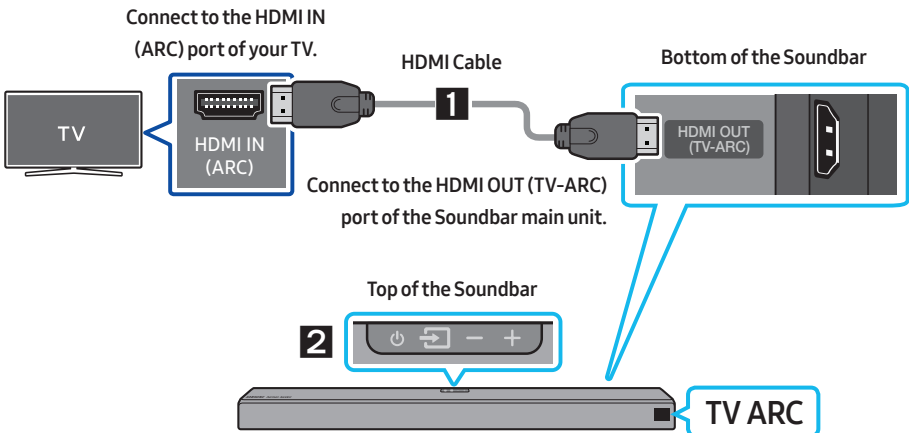

1. With the Soundbar and TV turned on, connect the HDMI cable as shown in the figure.
2. “TV ARC” appears in the display window of the Soundbar main unit and the Soundbar plays TV sound.
  - If TV sound is inaudible, press the  (**Source**) button on the remote control or on the top of the Soundbar to switch to “D.IN” mode. The screen displays “D.IN” and “TV ARC” in sequence, and TV sound is played.

- If “**TV ARC**” does not appear in the display window of the Soundbar main unit, confirm that the HDMI cable is connected to the correct port.
- Use the volume buttons on the TV’s remote control to change the volume on the Soundbar.

## NOTES

- HDMI is an interface that enables the digital transmission of video and audio data with just a single connector.
- If the TV provides an ARC port, connect the HDMI cable to the HDMI IN (ARC) port.
- We recommend you use a coreless HDMI cable if possible. If you use a cored HDMI cable, use one whose diameter is less than 0.55 inches (14 mm).
- Anynet+ must be turned on.
- This function is not available if the HDMI cable does not support ARC.

## Connecting using an Optical Cable

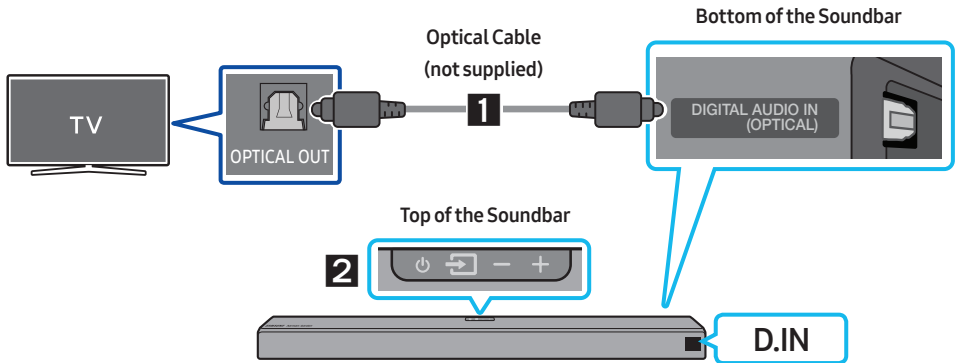

1. Connect the **DIGITAL AUDIO IN (OPTICAL)** jack on the Soundbar to the OPTICAL OUT jack of the TV with a digital optical cable (not supplied).
2. Press the  (**Source**) button on the top panel or remote control, and then select the “**D.IN**” mode.

## Auto Power Link

Auto Power Link automatically turns on the Soundbar when the TV is turned on.

1. Connect the Soundbar and a TV with a digital optical cable (not supplied) as described in Step 1 on the previous page.
2. Press the **Left** button on the remote control (the blue spot in the illustration to the right) for 5 seconds to turn Auto Power Link on or off.
  - Auto Power Link is set to ON by default.  
(To turn off this function, press the **Left** button on the remote for 5 seconds.)
  - Depending on the connected device, Auto Power Link may not function.
  - This function is only available in the “**D.IN**” mode.



## Method 2. Connecting Wirelessly

### Connecting a TV via Bluetooth

When a TV is connected using Bluetooth, you can hear stereo sound without the hassle of cabling.

- Only one TV can be connected at a time.

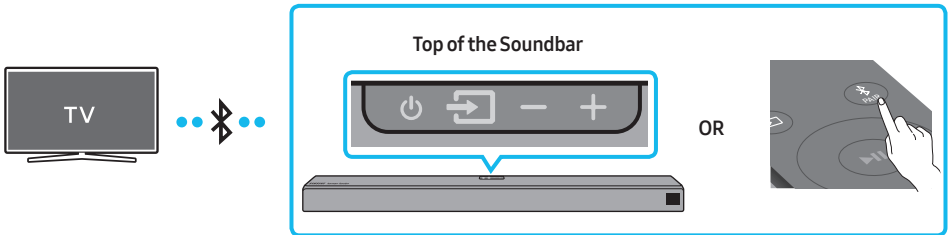

### The initial connection

1. Press the **PAIR** button on the remote control to enter the “**BT PAIRING**” mode.  
**(OR)** a. Press the **Source** button on the top panel and then select “**BT**”.  
“**BT**” changes to “**BT READY**” in a few seconds automatically if there is no Bluetooth device connected to the Soundbar.  
b. When “**BT READY**” appears, press and hold the **Source** button on the top panel of the Soundbar for more than 5 seconds to display “**BT PAIRING**”.
2. Select Bluetooth mode on the TV. (For more information, see the TV’s manual.)
3. Select “[AV] Samsung Soundbar Q90R” from the list on TV’s screen.  
An available Soundbar is indicated with “**Need Pairing**” or “**Paired**” on the TV’s Bluetooth device list. To connect the TV to the Soundbar, select the message, and then establish a connection.
  - When the TV is connected, [TV Name] → “**BT**” appears on the Soundbar’s front display.
4. You can now hear TV sound from the Soundbar.

## If the device fails to connect

- If a previously connected Soundbar (e.g. “[AV] Samsung Soundbar Q90R”) appears in the list, delete it.
- Then repeat steps 1 through 3.

## NOTE



- After you have connected the Soundbar to your TV the first time, use the “**BT READY**” mode to reconnect.

## Disconnecting the Soundbar from the TV

Press the  (**Source**) button on the top panel or on the remote control and switch to any mode but “**BT**”.

- Disconnecting takes time because the TV must receive a response from the Soundbar. (The time required may differ, depending on the TV model.)
- To cancel the automatic Bluetooth connection between the Soundbar and TV, press the **▶|| (Play/Pause)** button on the remote control for 5 seconds with the Soundbar in “**BT READY**” status. (Toggle On → Off)

## What is the difference between BT READY and BT PAIRING?

- **BT READY** : In this mode, you can search for previously connected TVs or connect a previously connected mobile device to the Soundbar.
- **BT PAIRING** : In this mode, you can connect a new device to the Soundbar. (Press the  **PAIR** button on the remote control or press and hold the  (**Source**) button on the top of the Soundbar for more than 5 seconds while the Soundbar is in “**BT**” mode.)

## NOTES

- If asked for a PIN code when connecting a Bluetooth device, enter <0000>.
- In Bluetooth connection mode, the Bluetooth connection will be lost if the distance between the Soundbar and the Bluetooth device exceeds **32.8 ft (10 m)**.
- The Soundbar automatically turns off after 18 minutes in the Ready state.
- The Soundbar may not perform Bluetooth search or connection correctly under the following circumstances:
  - If there is a strong electrical field around the Soundbar.
  - If several Bluetooth devices are simultaneously paired with the Soundbar.
  - If the Bluetooth device is turned off, not in place, or malfunctions.
- Electronic devices may cause radio interference. Devices that generate electromagnetic waves must be kept away from the Soundbar main unit - e.g., microwaves, wireless LAN devices, etc.

# Connecting via Wi-Fi

## Pre-connection Checklist

1. Confirm that your **Samsung Smart TV was released after 2013**. This function is compatible only with Samsung Smart TVs released after 2013.
2. Make sure your **Wireless router (Wi-Fi)** is ready and working.
3. Make sure that the **TV is connected to the Wireless router (your Wi-Fi network)**.

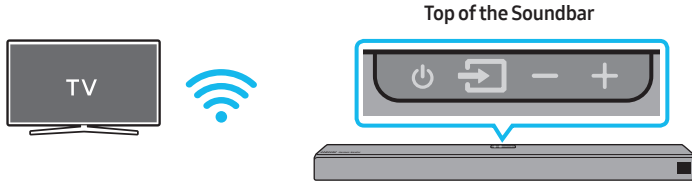

## Step 1 : Connecting the Soundbar to Wi-Fi

1. Press the  (**Source**) button on the top of the Soundbar or on the remote control to select “**WIFI**” mode.
  - When using selected Samsung TVs (2016 ~ 2018 Samsung Smart TVs that support Bluetooth.)
    - If you select “**WIFI**” mode when the TV is turned on, the TV screen displays a pop-up window providing instructions on how to automatically connect the Soundbar to a wireless router (Wi-Fi). Refer to the instructions in the pop-up window of the TV.

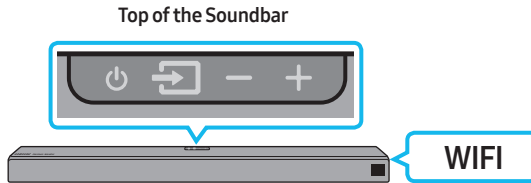

2. Connect your mobile device (smartphone, tablet, etc.) to the Wi-Fi network the TV is connected to.
3. Install and launch the **SmartThings** app on your mobile device (smartphone, tablet, etc.).

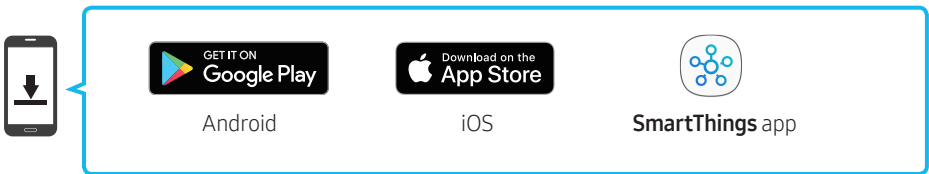

4. Follow the instructions in the app screen on the mobile device to connect the Soundbar to your Wi-Fi network.

## Step 2 : Configuring Settings on the TV

- If the TV disconnects from your wireless network after you change the input source to the Soundbar, use the TV menu to connect the TV to the network again.

### For TVs released in 2019

Home (🏠) → Settings (⚙️) → Sound → Sound Output → [AV] Samsung Soundbar Q90R (Wi-Fi)

### For TVs released in 2018

Home (🏠) → Settings (⚙️) → Sound → Sound Output → [AV] Samsung Soundbar Q90R (Wi-Fi)

### For TVs released in 2017

Home (🏠) → Settings (⚙️) → Sound → Sound Output → [AV] Samsung Soundbar Q90R (Wi-Fi)

### For TVs released in 2016

Home (🏠) → Settings (⚙️) → Sound → Select Speaker → [AV] Samsung Soundbar Q90R (Wi-Fi)

### For TVs released in 2015

Menu → Sound → Speaker List

### For TVs released in 2014

Menu → Sound → Speaker Settings → Multiroom Link - Settings

## NOTES

- The TV and Soundbar must be connected to the same wireless network (Wi-Fi).
- If your wireless router (Wi-Fi) uses a DFS channel, you will not be able to establish a Wi-Fi connection between the TV and Soundbar. Contact your Internet service provider for details.
- If the 5GHz Wi-Fi connection is not smooth, use the 2.4GHz bandwidth.
- Because the menus may differ depending on the year of manufacture, refer to your TV manual.





# 05 CONNECTING AN EXTERNAL DEVICE

Connect to an external device via a wired or wireless network to play the external device's sound through the Soundbar.

## Connecting using an HDMI Cable (Capable of Dolby Atmos decoding and playback)

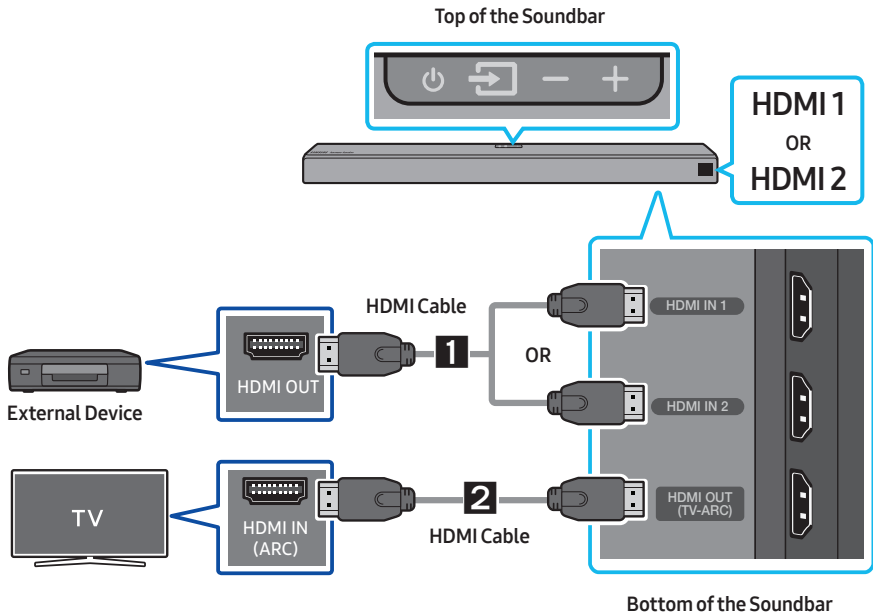
- **When you use Dolby Atmos®:** If the input source is Dolby Atmos®, 7.1.4 channels are outputted. When Dolby Atmos® is active, the Soundbar's sound effect modes controlled by the **SOUND MODE** button are not available.
- **Important:** This product supports Dolby Atmos® only in HDMI mode.



1. Connect an HDMI cable from the **HDMI IN 1** or **HDMI IN 2** jack on the bottom of the Soundbar to the HDMI OUT jack on your digital device.
2. Connect an HDMI cable from the **HDMI OUT (TV-ARC)** jack on the bottom of the Soundbar to the HDMI IN jack on your TV.
3. Press the  (**Source**) button on the top panel or on the remote control, and then select "HDMI1" or "HDMI2".
4. "HDMI1" or "HDMI2" mode is displayed on the Soundbar display panel and sound plays.

## NOTE

- When Dolby Atmos® is activated, “DOLBY ATMOS” appears in the front display.

### Configuring Dolby Atmos® on your BD player or other device.

- Open the audio output options on the settings menu of your BD player or other device and make sure that “No Encoding” is selected for Bitstream. For example, on a Samsung BD Player, go to Home Menu → Sound → Digital Output and then select Bitstream (unprocessed).
- If the Audio Output options include Secondary Audio, make sure Secondary Audio is set to Off.
- Make sure that the content supports Dolby Atmos®.

## Connecting using an HDMI Cable

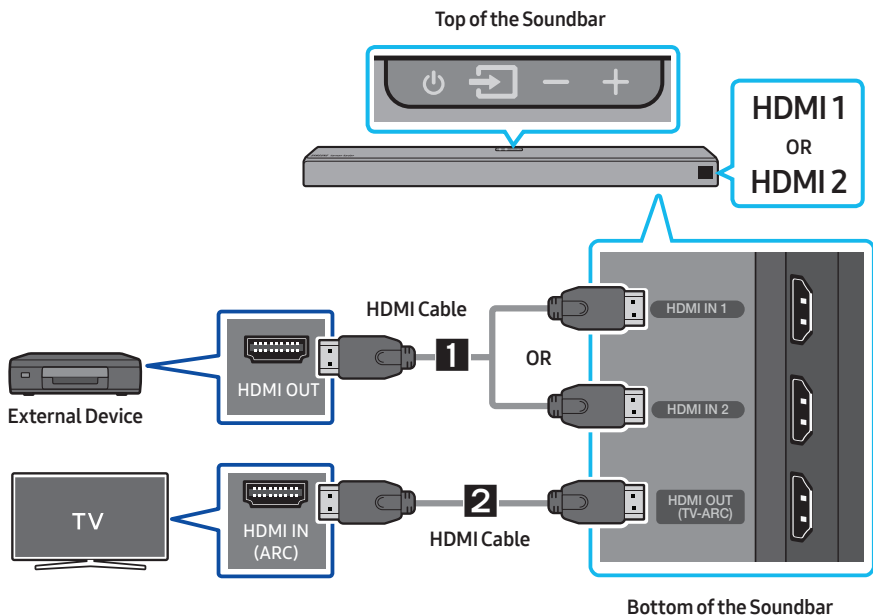

1. Connect an HDMI cable from the **HDMI IN 1** or **HDMI IN 2** jack on the bottom of the Soundbar to the HDMI OUT jack on your digital device.
2. Connect an HDMI cable from the **HDMI OUT (TV-ARC)** jack on the bottom of the Soundbar to the HDMI IN jack on your TV.
3. Press the  (**Source**) button on the top panel or on the remote control, and then select “HDMI1” or “HDMI 2”.
4. “HDMI1” or “HDMI 2” mode is displayed on the Soundbar display panel and sound plays.

# Connecting using an Optical Cable

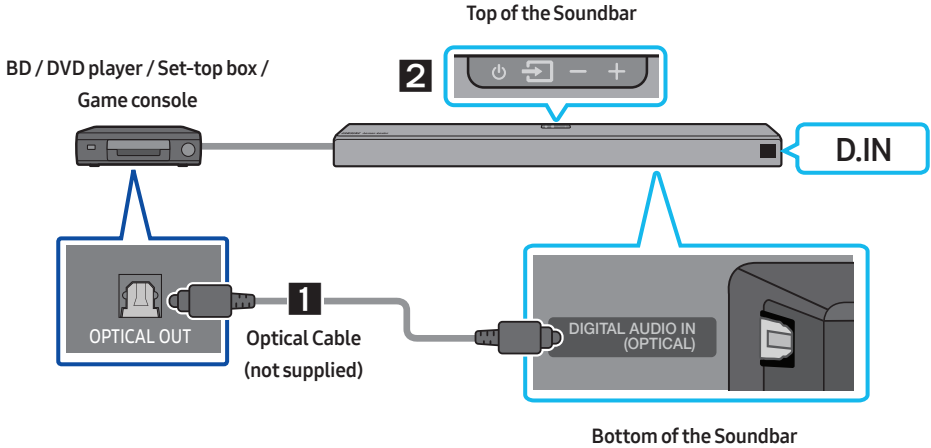

1. Connect **DIGITAL AUDIO IN (OPTICAL)** on the main unit to the OPTICAL OUT jack of the Source Device using a digital optical cable (not supplied).
2. Select “D.IN” mode by pressing the  (**Source**) button on the top panel or on the remote control.

# 06 CONNECTING A MOBILE DEVICE

## Connecting via Bluetooth

When a mobile device is connected using Bluetooth, you can hear stereo sound without the hassle of cabling.

- You cannot connect more than one Bluetooth device at a time.

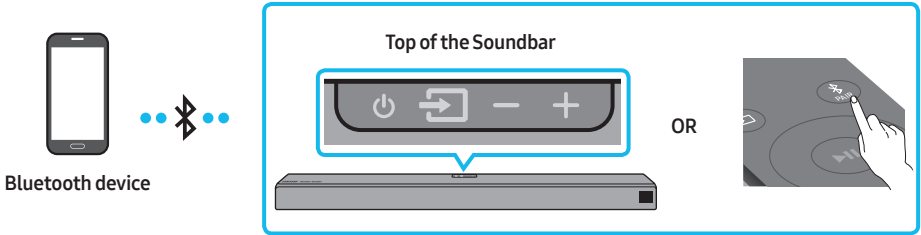

### The initial connection

1. Press the **PAIR** button on the remote control to enter the **"BT PAIRING"** mode.  
**(OR)** a. Press the **(Source)** button on the top panel and then select **"BT"**.  
"BT" changes to **"BT READY"** in a few seconds automatically if there is no Bluetooth device connected to the Soundbar.  
b. When **"BT READY"** appears, press and hold the **(Source)** button on the top panel of the Soundbar for more than 5 seconds to display **"BT PAIRING"**.
2. On your device, select **"[AV] Samsung Soundbar Q90R"** from the list that appears.
  - When the Soundbar is connected to the Bluetooth device, **[Bluetooth Device Name]** → **"BT"** appears in the front display.
3. Play music files from the device connected via Bluetooth through the Soundbar.



### If the device fails to connect

- If a previously connected Soundbar (e.g. **"[AV] Samsung Soundbar Q90R"**) appears in the list, delete it.
- Then repeat steps 1 and 2.

### NOTE

- After you have connected the Soundbar to your mobile device the first time, use the **"BT READY"** mode to reconnect.

## What is the difference between BT READY and BT PAIRING?

- **BT READY** : In this mode, you can search for previously connected TVs or connect a previously connected mobile device to the Soundbar.
- **BT PAIRING** : In this mode, you can connect a new device to the Soundbar. (Press the  **PAIR** button on the remote control or press and hold the  (**Source**) button on the top of the Soundbar for more than 5 seconds while the Soundbar is in “**BT**” mode.)

## NOTES

- If asked for a PIN code when connecting a Bluetooth device, enter <0000>.
- In Bluetooth connection mode, the Bluetooth connection will be lost if the distance between the Soundbar and the Bluetooth device exceeds **32.8 ft (10 m)**.
- The Soundbar automatically turns off after 18 minutes in the Ready state.
- The Soundbar may not perform Bluetooth search or connection correctly under the following circumstances:
  - If there is a strong electrical field around the Soundbar.
  - If several Bluetooth devices are simultaneously paired with the Soundbar.
  - If the Bluetooth device is turned off, not in place, or malfunctions.
- Electronic devices may cause radio interference. Devices that generate electromagnetic waves must be kept away from the Soundbar main unit - e.g., microwaves, wireless LAN devices, etc.
- The Soundbar supports SBC data (44.1kHz, 48kHz).
- Connect only to a Bluetooth device that supports the A2DP (AV) function.
- You cannot connect the Soundbar to a Bluetooth device that supports only the HF (Hands Free) function.
- Once you have paired the Soundbar to a Bluetooth device, selecting “[**AV**] **Samsung Soundbar Q90R**” from the device’s scanned devices list will automatically change the Soundbar to “**BT**” mode.
  - Available only if the Soundbar is listed among the Bluetooth device’s paired devices.  
(The Bluetooth device and the Soundbar must have been previously paired at least once.)
- The Soundbar will appear in the Bluetooth device’s searched devices list only when the Soundbar is displaying “**BT READY**”.
- The Soundbar cannot be paired to another Bluetooth device if already in Bluetooth mode and paired to a Bluetooth device.

## Disconnecting the Bluetooth device from a Soundbar

You can disconnect a Bluetooth device from the Soundbar. For instructions, see the Bluetooth device's user manual.

- The Soundbar will be disconnected.
- When the Soundbar is disconnected from the Bluetooth device, the Soundbar will display **"BT DISCONNECTED"** on the front display.

## Disconnecting the Soundbar from the Bluetooth device

Press the  (**Source**) button on the top panel or on the remote control, and then change to any mode except **"BT"**.

- Disconnecting takes time because the Bluetooth device must receive a response from the Soundbar. (Disconnection time may differ, depending on the Bluetooth device)
- When the Soundbar is disconnected from the Bluetooth device, the Soundbar will display **"BT DISCONNECTED"** on the front display.

### NOTES

- In Bluetooth connection mode, the Bluetooth connection will be lost if the distance between the Soundbar and the Bluetooth device exceeds **32.8 ft (10 m)**.
- The Soundbar automatically turns off after 18 minutes in the Ready state.

### More About Bluetooth

Bluetooth is a technology that enables Bluetooth-compliant devices to interconnect easily with each other using a short wireless connection.

- A Bluetooth device may cause noise or malfunction, depending on usage, if:
  - A part of your body is in contact with the receiving/transmitting system of the Bluetooth device or the Soundbar.
  - It is subject to electrical variation from obstructions caused by a wall, corner, or office partition.
  - It is exposed to electrical interference from same frequency-band devices including medical equipment, microwave ovens, and wireless LANs.
- Pair the Soundbar with the Bluetooth device while they are close together.
- The further the distance between the Soundbar and Bluetooth device, the worse the quality is. If the distance exceeds the Bluetooth operational range, the connection is lost.
- In poor reception areas, the Bluetooth connection may not work properly.
- The Bluetooth connection only works when it is close to the unit. The connection will be automatically cut off if the Bluetooth device is out of range. Even within range, the sound quality may be degraded by obstacles such as walls or doors.
- This wireless device may cause electric interference during its operation.

## Connecting via Wi-Fi (Wireless Network)

- Connect a single Soundbar to Wi-Fi to access a variety of music streaming services and Internet radio. Connect multiple Soundbars to Wi-Fi to use grouped playback or the stereo sound mode.
- To connect a Soundbar to a mobile device via a wireless network (Wi-Fi), the **SmartThings** app is required.

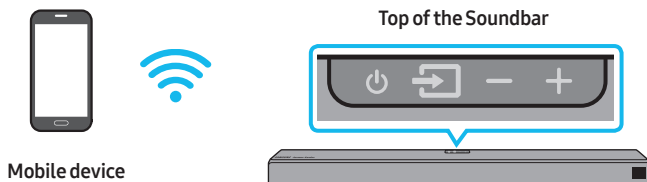

### The initial connection

1. Press the  (**Source**) button on the top of the Soundbar or on the remote control to select "WIFI" mode.

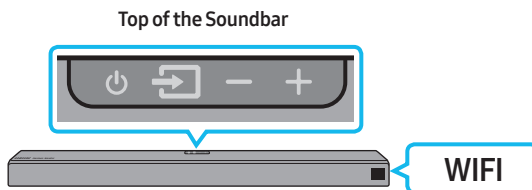

2. Install and launch the **SmartThings** app on your mobile device (e.g. smartphone or tablet).

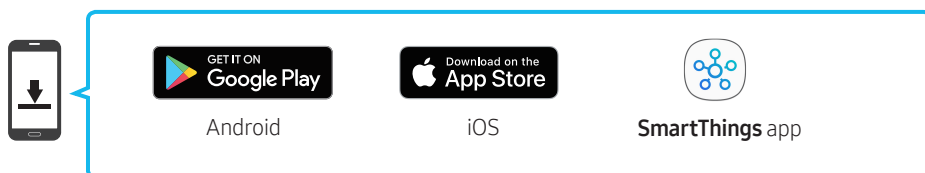

3. Launch the app, and then follow the instructions on the screen to register (add) your Soundbar in the app.
- The automatic pop-up (the third illustration below) may not be available on some mobile devices.
- If this is the case, select and complete “**Add device**” from the app menu. Your Soundbar is now added to the app.

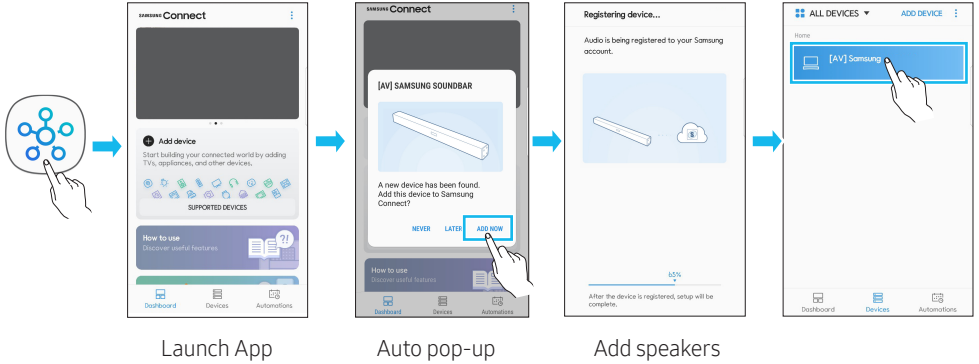



# 07 CONNECTING AN AMAZON PRODUCT

- This feature may not be available in some countries.
- This service is provided by Amazon and can be terminated at any time. Samsung does not assume responsibility for service availability.
- **Amazon Alexa** app screen is subject to change without prior notice.

## Connect and use with an Amazon product (Amazon Echo)

Use an Amazon Echo product to control your Soundbar and enjoy music services provided by Amazon Echo.

### NOTE

- Confirm that the Soundbar is connected to Wi-Fi. (Refer to “Connecting via Wi-Fi (Wireless Network)”)

1. In the **SmartThings** app, change your Soundbar’s name to one that can be recognized by your Amazon device.  
(Example: Samsung, Soundbar, Living Room, Family Room, Bedroom, Office, etc.)

### ⚠ CAUTION

- Amazon devices may not recognize names that contain elements such as special characters.

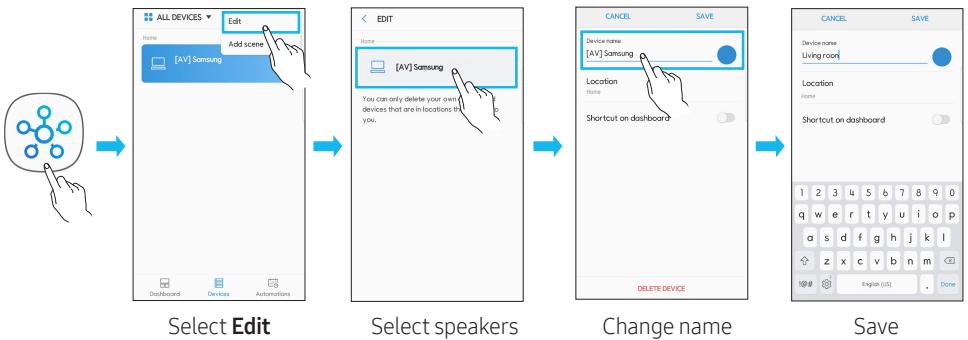

2. In the **Alexa** app, search “**Samsung Wireless Audio**” in **Skills**, and then select “**ENABLE**”.

- Skip this step if you have **Skills** set up already.

Amazon Alexa app

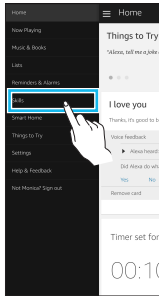

Select **Skills**

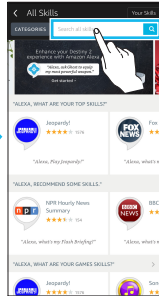

Search

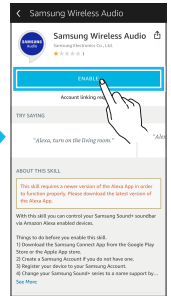
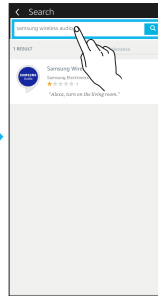

Enable

# Use voice commands to control the Soundbar

- The Amazon Echo service you can use with your Soundbar is limited to music. Other services provided by Amazon Echo, such as news and weather, can only be accessed through your Amazon Echo product.



Trigger + **Command** + **Speaker name**

Use the **Speaker name** you changed in the SmartThings app. (Refer to “Connect and use with an Amazon product (Amazon Echo)”)

Action	Voice Command
To search an audio device added to the <b>SmartThings</b> account connected to the <b>Amazon Alexa</b> account	"Alexa <b>Discover devices</b> "







\* To use voice commands for the Soundbar named “**Living room**”

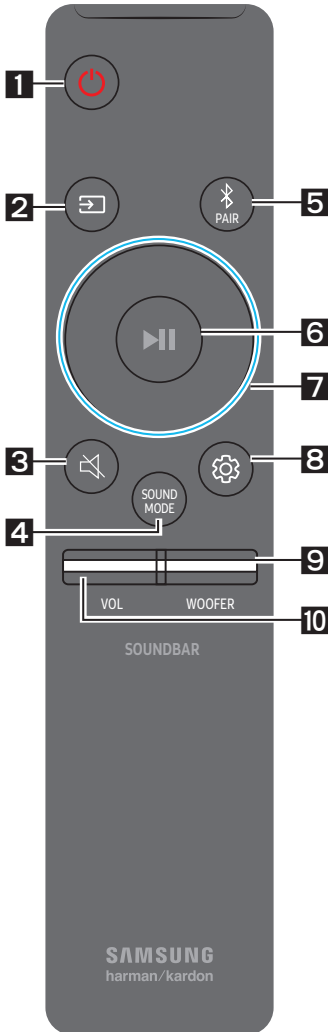

Action	Voice Command
To set the volume level to 5	"Alexa <b>Set the volume to 5 on Living room</b> "
To increase the volume level	"Alexa <b>Volume up on Living room</b> "
To mute the sound	"Alexa <b>Mute on Living room</b> "
To listen to a radio station named KISS FM	"Alexa <b>Play Kiss FM on Living room</b> "
To play the next song	"Alexa <b>Next song on Living room</b> "
To stop the audio	"Alexa <b>Stop on Living room</b> "
To turn the audio on	"Alexa <b>Turn on Living room</b> "
To turn the audio off	"Alexa <b>Turn off Living room</b> "
To change the input source	"Alexa <b>Switch to Bluetooth on Living room</b> "







# 08 USING THE REMOTE CONTROL

## How to Use the Remote Control

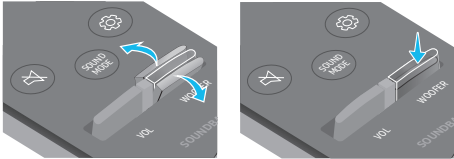

<p><b>1</b></p>	 <b>Power</b>	<p>Turns the Soundbar on and off.</p>
<p><b>2</b></p>	 <b>Source</b>	<p>Press to select a source connected to the Soundbar.</p>
<p><b>3</b></p>	 <b>Mute</b>	<p>Press the  (<b>Mute</b>) button to mute the sound. Press it again to unmute the sound.</p>
<p><b>4</b></p>	 <b>SOUND MODE</b>	<p>You can select the desired sound mode by choosing <b>STANDARD</b>, <b>SURROUND</b>, <b>GAME PRO</b>, or <b>ADAPTIVE SOUND</b>.</p> <p>Select the <b>STANDARD</b> mode if you want to enjoy the original sound.</p> <ul style="list-style-type: none"> <li>• <b>GAME PRO mode</b> Immerse yourself in the scene with a dedicated setting that optimizes sounds specifically for gaming.</li> <li>• <b>ADAPTIVE SOUND mode</b> Automatically analyzes content and gives you optimized sound and automatically enhances voice clarity on low volumes.</li> </ul>
<p><b>5</b></p>	 <b>Bluetooth PAIR</b>	<p>Press the  <b>PAIR</b> button. “<b>BT PAIRING</b>” appears in the Soundbar’s display.</p> <p>You can connect the Soundbar to a new Bluetooth device in this mode by selecting the Soundbar from the Bluetooth device’s search list.</p>

<p><b>6</b></p>	 <p>Play / Pause (BT/Wi-Fi)</p>	<p>Press the ►   button to pause a music file temporarily. When you press the button again, the music file plays.</p>
<p><b>7</b></p>	 <p>Up/Down/ Left/Right</p>	 <p>Press the indicated areas to select Up/Down/Left/Right.</p> <p>Press Up/Down/Left/Right on the button to select or set functions.</p> <ul style="list-style-type: none"> <li>• <b>Music Skip</b> Press the <b>Right</b> button to select the next music file. Press the <b>Left</b> button to select the previous music file.</li> <li>• <b>Anynet+ / Auto Power Link</b> You can turn Anynet+ and Auto Power Link on or off. Anynet+ and Auto Power Link are turned on and turned off by the <b>Right</b> and <b>Left</b> buttons respectively. <ul style="list-style-type: none"> <li>– Anynet+ : If the Soundbar is connected to a Samsung TV through an HDMI cable, you can control your Soundbar with a Samsung TV remote control. Press and hold the <b>Right</b> button for 5 seconds to toggle Anynet+ ON and OFF.</li> <li>– Auto Power Link : If the Soundbar is connected to your TV through a digital optical cable, the Soundbar can automatically turn on when you turn on your TV. Press and hold the <b>Left</b> button for 5 seconds to toggle Auto Power Link ON and OFF.</li> <li>– Anynet+ / Auto Power Link are set to ON by default.</li> </ul> </li> <li>• <b>ID SET</b> Press and hold the <b>Up</b> button for 5 seconds to complete <b>ID SET</b>.</li> </ul>

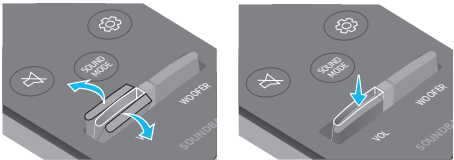
<p><b>8</b></p>	 <p><b>Sound Control</b></p>	<p>You can select <b>TREBLE</b>, <b>BASS</b>, <b>SYNC</b>, <b>CENTER LEVEL</b>, <b>SIDE LEVEL</b>, <b>FRONT TOP LEVEL</b>, <b>REAR LEVEL</b>, <b>REAR TOP LEVEL</b>, and <b>VIRTUAL ON/OFF</b>.</p> <ul style="list-style-type: none"> <li>- To control the volume of the treble or bass sound, select <b>TREBLE</b> or <b>BASS</b> in Sound Settings, and then adjust the volume between -6~+6 by using the <b>Up/Down</b> buttons.</li> <li>- Press and hold the  (<b>Sound Control</b>) button for about 5 seconds to adjust the sound for each frequency band. 150Hz, 300Hz, 600Hz, 1.2kHz, 2.5kHz, 5kHz, and 10kHz are selectable using the <b>Left/Right</b> buttons and each can be adjusted to a setting between -6 to +6 using the <b>Up/Down</b> buttons.</li> <li>- To control the volume of the each speaker select <b>CENTER LEVEL</b>, <b>SIDE LEVEL</b> or <b>FRONT TOP LEVEL</b> in Sound Settings, and then adjust the volume between -6~+6 by using the <b>Up/Down</b> buttons.</li> <li>- If the video on the TV and audio from the Soundbar are not synchronized, select <b>SYNC</b> in Sound Control, and then set the audio delay between 0~300 milliseconds by using the <b>Up/Down</b> buttons.</li> <li>- If Surround Speakers are connected, select <b>REAR LEVEL</b> or <b>REAR TOP LEVEL</b>, and then use the <b>Up/Down</b> buttons to adjust the volume within a -6 to +6 range. The <b>VIRTUAL</b> Speaker function can be turned <b>ON/OFF</b> by using the <b>Up/Down</b> buttons.</li> <li>- <b>SYNC</b> is only supported for some functions.</li> <li>• <b>Initialize</b> With the Soundbar turned off, press and hold the  (<b>Sound Control</b>) button for more than 5 seconds until the speaker turns on. "INIT" appears on the display and the Soundbar is initialized.</li> </ul>
<p><b>9</b></p>	 <p><b>WOOFER</b></p>	 <p>Push the button up or down to adjust the volume of the subwoofer to -12 or between -6 to +6. To set the subwoofer volume level to 0, press the button.</p>
<p><b>10</b></p>	 <p><b>VOL</b></p>	 <p>Push the button up or down to adjust the volume.</p> <ul style="list-style-type: none"> <li>• <b>Mute</b> Press the <b>VOL</b> button to mute the sound. Press it again to unmute the sound.</li> </ul>

# Adjusting the Soundbar volume with a TV remote control

If you have a Samsung TV, you can adjust the Soundbar's volume using the IR remote control that came with your Samsung TV.

First use the TV menu to set the TV audio on your Samsung TV to external speakers, then use your Samsung remote to control the Soundbar's volume. For more information, see the TV's user manual. The default mode for this function is control by a Samsung TV remote. If your TV is not a Samsung TV, follow the directions below to change the settings of this function.

1. Turn Off the Soundbar.

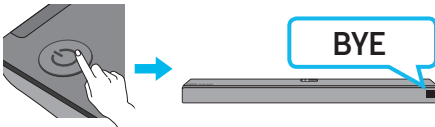

2. If you do not want to use this function, push up and hold the **WOOFER** button for 5 seconds repeatedly until "**OFF-TV REMOTE**" appears in the display.

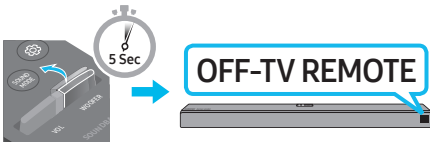

3. If you want to control the Soundbar with your TV's remote, push up and hold the **WOOFER** button for 5 seconds repeatedly until "**ALL-TV REMOTE**" appears in the display. Then, use your TV's menu to select external speakers.

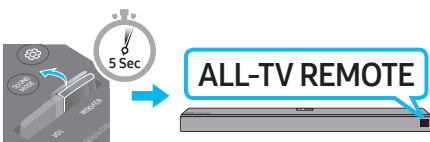

4. If you want to return the Soundbar to the default mode (control by a Samsung TV remote), push up and hold the **WOOFER** button for 5 seconds repeatedly until "**SAMSUNG-TV REMOTE**" appears in the display.

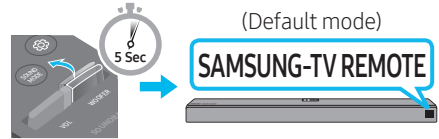

- Each time you push the **WOOFER** button up and hold it for 5 seconds, the mode switches in the following order: "**SAMSUNG-TV REMOTE**" (Default mode) → "**OFF-TV REMOTE**" → "**ALL-TV REMOTE**".
- This function may not be available, depending on the remote control.
- Manufacturers supporting this function: VIZIO, LG, Sony, Sharp, PHILIPS, PANASONIC, TOSHIBA, GRUNDIG, Hisense, RCA

## Using the Hidden Buttons (Buttons with more than one function)

Hidden Button		Reference page
Remote Control Button	Function	
WOOFER	TV remote control On/Off (Standby)	page 29
Left	Auto Power Link ON/OFF	page 27
Right	Anynet+ ON/OFF	page 27
Up	ID SET	page 27
 (Sound Control)	7 Band EQ	page 28
	Initialize (Standby)	page 28

## Output specifications for the different sound effect modes

Effect	Input	Output
		With Subwoofer & Surround Speaker
STANDARD	2.0 ch	2.1 ch
	5.1 ch	5.1 ch / 7.1 ch (DTS)
	7.1 ch	7.1 ch
	7.1.4 ch	7.1.4 ch
SURROUND	2.0 ch	7.1.4 ch
	5.1 ch	7.1.4 ch
	7.1 ch	7.1.4 ch
	7.1.4 ch	7.1.4 ch
GAME PRO	2.0 ch	2.1 ch
	5.1 ch	5.1 ch / 7.1 ch (DTS)
	7.1 ch	7.1 ch
	7.1.4 ch	7.1.4 ch
ADAPTIVE SOUND	2.0 ch	2.1 ch
	5.1 ch	5.1 ch / 7.1 ch (DTS)
	7.1 ch	7.1 ch
	7.1.4 ch	7.1.4 ch

- If the input source is Dolby Atmos®, 7.1.4 channels are outputted. The sound effect modes controlled by the **SOUND MODE** button and listed above are not available.



# 09 INSTALLING THE WALL MOUNT

## Installation Precautions

- Install on a vertical wall only.
- Do not install in a place with high temperature or humidity.
- Verify whether the wall is strong enough to support the product's weight. If not, reinforce the wall or choose another installation point.
- Purchase and use the fixing screws or anchors appropriate for the kind of wall you have (plaster board, iron board, wood, etc.). If possible, fix the support screws into wall studs.
- Purchase wall mounting screws according to the type and thickness of the wall you want to mount the Soundbar on.
  - Diameter: M5
  - Length: 1 3/8 inches (35 mm) or longer recommended.
- Connect cables from the unit to external devices before you install the Soundbar on the wall.
- Make sure the unit is turned off and unplugged before you install it. Otherwise, it may cause an electric shock.

## Wallmount Components



Wall Mount Guide (AH63-04369C)



Holder-Screw  
(AH61-04110A)



Screw  
(6001-001202)



Bracket-Wall Mount (AH61-04119A)

1. Place the **Wall Mount Guide** against the wall surface.
  - The **Wall Mount Guide** must be level.
  - If your TV is mounted on the wall, install the Soundbar at least 2 inches (5 cm) below the TV.



2 inches (5 cm) or more

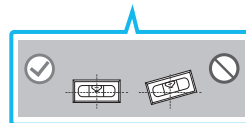

2. Align the **Wall Mount Guide's Center Line** with the center of your TV (if you are mounting the Soundbar below your TV), and then fix the **Wall Mount Guide** to the wall using tape.

- If you are not mounting below a TV, place the **Center Line** in the center of the installation area.

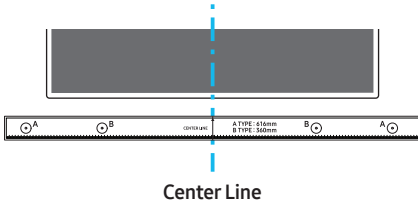

3. Push a pen tip or sharpened pencil tip through the center of the **A-TYPE** images on each end of the Guide to mark the holes for the supporting screws, and then remove the **Wall Mount Guide**.

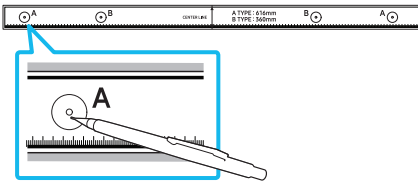

4. Using an appropriately sized drill bit, drill a hole in the wall at each marking.

- If the markings do not correspond to the positions of studs, make sure you insert appropriate anchors or mollies into the holes before you insert the support screws. If you use anchors or mollies, make sure the holes you drill are large enough for the anchors or mollies you use.

5. Push a screw (not supplied) through each **Holder-Screw**, and then screw each screw firmly into a support screw hole.

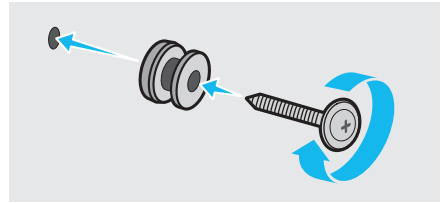

6. Install the 2 **Bracket-Wall Mounts** in the correct orientation on the bottom of the Soundbar using 2 **Screws**.

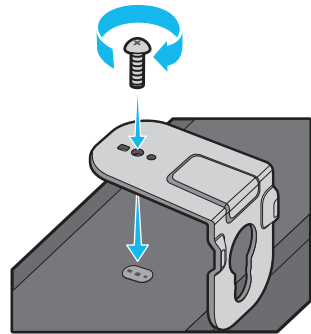

- When assembling, make sure the hanger part of the **Bracket-Wall Mounts** are located behind the rear of the Soundbar.

**Rear of Soundbar**

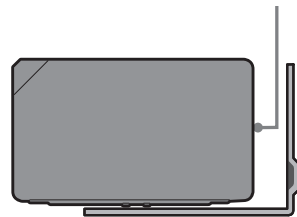

**Right end of Soundbar**

7. Install the Soundbar with the attached **Bracket-Wall Mounts** by hanging the **Bracket-Wall Mounts** on the **Holder-Screws** on the wall.

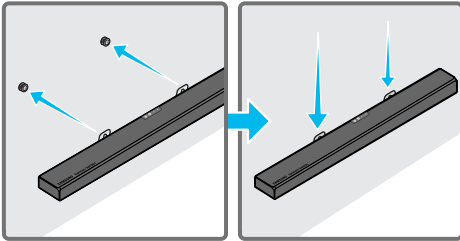

8. Slide the Soundbar down as shown below so that the **Bracket-Wall Mounts** rest securely on the **Holder-Screws**.

- Insert the **Holder-Screws** into the wide (bottom) part of the **Bracket-Wall Mounts**, and then slide the **Bracket-Wall Mounts** down so that the **Bracket-Wall Mounts** rest securely on the **Holder-Screws**.

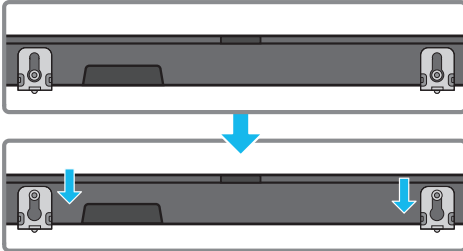

## Installing the Surround Speakers on a Wall (Sold Separately)

You can purchase wall mounts separately to install the surround speakers on a wall.

### Notes for Wall Mounting the Surround Speakers

- Surround Speaker wall mounts must be able to support more than 4.4 lbs (2.0 kg).
- Hole size : 1/4 - 20 UNC threaded insert
- Since wall-mount installation is optional, you must purchase the corresponding accessories separately.
- Please have a qualified installer install the surround speaker Wall Mount Brackets.
- Ask a professional installation company to mount your product on the wall.
- Check the strength of the wall before you install the Wall Mount Brackets. If the strength is insufficient, make sure to reinforce the wall before installing the Wall Mount Brackets and the speakers on the wall.
- For more information, please refer to the Wall Mount's manual.
- Samsung Electronics is not liable for any damage to the product due to the product being installed inappropriately.
- Take care not to install the speakers sideways or upside down.

# 10 INSTALLING THE SOUNDBAR ABOVE A TV STAND

## Component



x 4

**Rubber-Foot** (BN67-00398L)

You can install the Soundbar above TV stands that are less than 3 inches (7.6 cm) in height. To install, attach the **Rubber-Feet** to the bottom of the Soundbar before placing it in position above the TV stand. Make sure you attach the **Rubber-Feet** so that they are beyond the outside edges of the TV stand. Refer to the figure below.

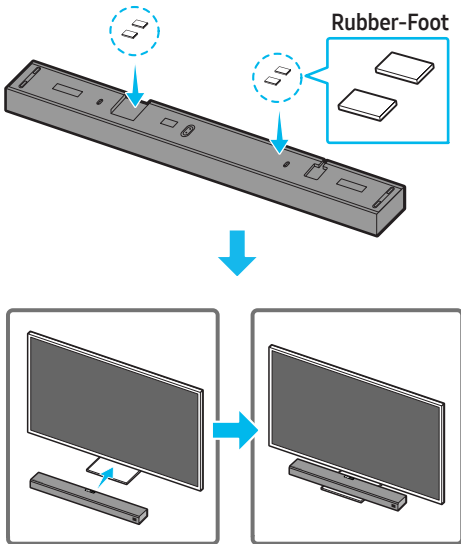

# 11 SOFTWARE UPDATE

When the Soundbar is connected to the Internet, software updates automatically occur even when the Soundbar is turned off.

- To use the Auto Update function, the Soundbar must be connected to the Internet. The Wi-Fi connection to the Soundbar will be terminated if the Soundbar's power cord is disconnected or the power is cut off. If the power is cut off, when the power comes back on or you reconnect the power cord, turn on the Soundbar, and then reconnect it to the Internet.

# 12 TROUBLESHOOTING

Refer to the instructions below if this product does not function properly. If the problem you are experiencing is not listed below or if the instructions below do not help, turn off the product, disconnect the power cord, and contact Samsung Electronics at 1-800-SAMSUNG (1-800-726-7864).

## The unit will not turn on.

### Is the power cord plugged into the outlet?

- Connect the power plug to the outlet.

## A function does not work when the button is pressed.

### Is there static electricity in the air?

- Disconnect the power plug and connect it again.

## Sound dropouts occur in BT mode.

- See the Bluetooth connection sections on pages 11 and 18.

## Sound is not produced.

### Is the Mute function on?

- Press the  (Mute) button to cancel the mute function.

### Is the volume set to minimum?

- Adjust the Volume.

## The remote control does not work.

### Are the batteries drained?

- Replace with new batteries.

### Is the distance between the remote control and Soundbar main unit too far?

- Move the remote control closer to the Soundbar main unit.

## The red LED on the subwoofer blinks and the subwoofer is not producing sound.

### This issue can occur if the subwoofer is not connected to the Soundbar main unit.

- Try to connect your subwoofer again.  
(See page 6.)

## The subwoofer drones and vibrates noticeably.

### Try to adjust the vibration of your subwoofer.

- Push the **WOOFER** button on your remote control up or down to adjust the subwoofer volume. (to -12, or between -6 ~ +6).

## Cannot connect to the TV.

### If connected via a wired network

- Check if the cable is connected correctly.
  - Check the port name to make sure that the cable is connected to the correct port. For instructions, see the page explaining each connection method.
- Press the  (Source) button on the top panel of the Soundbar or on the remote control to check if the mode is correct.

### If connected via a wireless network

#### → Connected via Bluetooth

1. Switch the Soundbar to “**BT PAIRING**” mode, and then use the TV to search again. (See page 11 for details.)

→ **Connected via Wi-Fi**

1. Check if the TV is a compatible model.
    - Only **Samsung Smart TVs** released after 2013 are supported.
  2. Check if the TV is connected to Wi-Fi.
    - If the TV is not connected to Wi-Fi, use the network menu on the TV to establish a connection. (See the TV user manual.)
  3. Check if the Soundbar is connected to Wi-Fi.
    - When the Soundbar is connected, you can find it in the list of speakers on your mobile device when you run the **SmartThings** app. See page 21 for details.
  4. Check for a DFS channel.
    - If your wireless router (Wi-Fi) is using a DFS channel, you cannot establish a Wi-Fi connection between the TV and Soundbar. Contact your Internet service provider for details.
- 

## 13 LICENSE

---



---

Manufactured under license from Dolby Laboratories. Dolby, Dolby Atmos, Dolby Audio, Dolby Digital Plus, Pro Logic, and the double-D symbol are trademarks of Dolby Laboratories.

---



---

For DTS patents, see <http://patents.dts.com>. Manufactured under license from DTS Licensing Limited. DTS, the Symbol, & DTS and the Symbol together, DTS:X, and the DTS:X logo are registered trademarks and/or trademarks of DTS, Inc. in the United States and/or other countries. © DTS, Inc. All Rights Reserved.

---



---

The terms HDMI and HDMI High-Definition Multimedia Interface, and the HDMI Logo are trademarks or registered trademarks of HDMI Licensing LLC in the United States and other countries.

---



- 
- The Spotify Software is subject to third party licenses found here : [www.spotify.com/connect/third-party-licenses](http://www.spotify.com/connect/third-party-licenses).
  - For more information about Spotify Connect, please visit [www.spotify.com/connect](http://www.spotify.com/connect)
-

# 14 OPEN SOURCE LICENSE NOTICE

For further information on Open Sources used in this product, please visit the website:

<http://opensource.samsung.com>

# 15 IMPORTANT NOTES ABOUT SERVICE

- Figures and illustrations in this User Manual are provided for reference only and may differ from actual product appearance.
- An administration fee may be charged if either:
  - a. An engineer is called out to your home at your request and there is no defect in the product.
  - b. You bring the unit to a repair center and there is no defect in the product.
- You will be advised of the amount of the administration fee before any work is done or a home visit is made.
- If you have a problem with this product, we strongly recommend you read the appropriate section of this manual, visit the Support page for your product at [www.samsung.com](http://www.samsung.com), or call Samsung Product Support (1-800-726-7864) to find an answer before you contact a service center for a repair.

# 16 SPECIFICATIONS AND GUIDE

## Specifications

Model Name	HW-Q90R
Weight	19.4 lbs (8.8 kg)
Dimensions (W x H x D)	48.3 x 3.3 x 5.4 inches (1226.0 x 83.0 x 136.0 mm)
Operating Temperature Range	+41°F to +95°F (+5°C to +35°C)
Operating Humidity Range	10 % ~ 75 %
AMPLIFIER Rated Output power	18W x 10 + 10W x 3, 4ohm
Supported play formats	LPCM 8ch, Dolby Digital, Dolby Atmos (True HD / Digital Plus), DTS:X

Subwoofer Name	PS-WR95B
Weight	21.6 lbs (9.8 kg)
Dimensions (W x H x D)	8.1 x 15.9 x 15.9 inches (205.0 x 403.0 x 403.0 mm)
AMPLIFIER Rated Output power	160W

Surround Speaker Name	PS-SQ90-1, PS-SQ90-2
Weight	4.6 lbs (2.1 kg)
Dimensions (W x H x D)	4.7 x 8.3 x 5.6 inches (120.0 x 210.0 x 141.0 mm)
AMPLIFIER Rated Output power	35W x 4

### NOTES

- Samsung Electronics Co., Ltd reserves the right to change the specifications without notice.
- Weight and dimensions are approximate.
- Dispose unwanted electronics through an approved recycler.

To find the nearest recycling location, go to our website: [www.samsung.com/recycling](http://www.samsung.com/recycling) or call 1-800-SAMSUNG.

### Precaution : The Soundbar will restart automatically if you turn on/turn off Wi-Fi.

Wi-Fi Port deactivation method	Press the <b>ID SET</b> button on the bottom panel of the Soundbar for 30 seconds to turn Wi-Fi On / Off.
Bluetooth Port deactivation method	Press the <b>NETWORK</b> button on the bottom panel of the Soundbar for 30 seconds to turn Bluetooth On / Off.



## LIMITED WARRANTY TO ORIGINAL PURCHASER

This SAMSUNG brand product, as supplied and distributed by SAMSUNG and delivered new, in the original carton to the original consumer purchaser, is warranted by SAMSUNG against manufacturing defects in materials and workmanship for a limited warranty period of:

### **One (1) Year Parts and Labor\*** **(\*90 Days Parts and Labor for Commercial Use)**

This limited warranty begins on the original date of purchase, and is valid only on products purchased and used in the United States. To receive warranty service, the purchaser must contact SAMSUNG for problem determination and service procedures. Warranty service can only be performed by a SAMSUNG authorized service center. The original dated bill of sale must be presented upon request as proof of purchase to SAMSUNG or SAMSUNG's authorized service center. Transportation of the product to and from the service center is the responsibility of the purchaser. SAMSUNG will repair or replace this product, at our option and at no charge as stipulated herein, with new or reconditioned parts or products if found to be defective during the limited warranty period specified above. All replaced parts and products become the property of SAMSUNG and must be returned to SAMSUNG. Replacement parts and products assume the remaining original warranty, or ninety (90) days, whichever is longer. SAMSUNG's obligations with respect to software products distributed by SAMSUNG under the SAMSUNG brand name are set forth in the applicable end user license agreement. Non-SAMSUNG hardware and software products, if provided, are on an "AS IS" basis.

Non-SAMSUNG manufacturers, suppliers, publishers, and service providers may provide their own warranties. This limited warranty covers manufacturing defects in materials and workmanship encountered in normal, and except to the extent otherwise expressly provided for in this statement, noncommercial use of this product, and shall not apply to the following, including, but not limited to: damage which occurs in shipment; delivery and installation; applications and uses for which this product was not intended; altered product or serial numbers; cosmetic damage or exterior finish; accidents, abuse, neglect, fire, water, lightning or other acts of nature; use of products, equipment, systems, utilities, services, parts, supplies, accessories, applications, installations, repairs, external wiring or connectors not supplied and authorized by SAMSUNG, or which damage this product or result in service problems; incorrect electrical line voltage, fluctuations and surges; customer adjustments and failure to follow operating instructions, cleaning, maintenance and environmental instructions that are covered and prescribed in the instruction book; product removal or reinstallation; reception problems and distortion related to noise, echo, interference or other signal transmission and delivery problems. SAMSUNG does not warrant uninterrupted or error-free operation of the product.

THERE ARE NO EXPRESS WARRANTIES OTHER THAN THOSE LISTED AND DESCRIBED ABOVE, AND NO WARRANTIES WHETHER EXPRESS OR IMPLIED, INCLUDING, BUT NOT LIMITED TO, ANY IMPLIED WARRANTIES OF MERCHANTABILITY OR FITNESS FOR A PARTICULAR PURPOSE, SHALL APPLY AFTER THE EXPRESS WARRANTY PERIODS STATED ABOVE, AND NO OTHER EXPRESS WARRANTY OR GUARANTY GIVEN BY ANY PERSON, FIRM OR CORPORATION WITH RESPECT TO THIS PRODUCT SHALL BE BINDING ON SAMSUNG. SAMSUNG SHALL NOT BE LIABLE FOR LOSS OF REVENUE OR PROFITS, FAILURE TO REALIZE SAVINGS OR OTHER BENEFITS, OR ANY OTHER SPECIAL, INCIDENTAL OR CONSEQUENTIAL DAMAGES CAUSED BY THE USE, MISUSE OR INABILITY TO USE THIS PRODUCT, REGARDLESS OF THE LEGAL THEORY ON WHICH THE CLAIM IS BASED, AND EVEN IF SAMSUNG HAS BEEN ADVISED OF THE POSSIBILITY OF SUCH DAMAGES. NOR SHALL RECOVERY OF ANY KIND AGAINST SAMSUNG BE GREATER IN AMOUNT THAN THE PURCHASE PRICE OF THE PRODUCT SOLD BY SAMSUNG AND CAUSING THE ALLEGED DAMAGE. WITHOUT LIMITING THE FOREGOING, PURCHASER ASSUMES ALL RISK AND LIABILITY FOR LOSS, DAMAGE OR INJURY TO PURCHASER AND PURCHASER'S PROPERTY AND TO OTHERS AND THEIR PROPERTY ARISING OUT OF THE USE, MISUSE OR INABILITY TO USE THIS PRODUCT SOLD BY SAMSUNG NOT CAUSED DIRECTLY BY THE NEGLIGENCE OF SAMSUNG. THIS LIMITED WARRANTY SHALL NOT EXTEND TO ANYONE OTHER THAN THE ORIGINAL PURCHASER OF THIS PRODUCT, IS NONTRANSFERABLE AND STATES YOUR EXCLUSIVE REMEDY.

Some states do not allow limitations on how long an implied warranty lasts, or the exclusion or limitation of incidental or consequential damages, so the above limitations or exclusions may not apply to you. This warranty gives you specific legal rights, and you may also have other rights which vary from state to state.

To obtain warranty service, please contact SAMSUNG customer care center.

The benefits of this Limited Warranty extend only to the original purchaser of Samsung products from an authorized Samsung reseller. THIS LIMITED WARRANTY SHALL NOT APPLY TO ANY SAMSUNG PRODUCTS PURCHASED FROM UNAUTHORIZED RESELLERS OR RETAILERS, EXCEPT IN STATES WHERE SUCH RESTRICTION MAY BE PROHIBITED. For a list of Samsung authorized retailers, please go to:

[http://www.samsung.com/us/peaceofmind/authorized\\_resellers.html](http://www.samsung.com/us/peaceofmind/authorized_resellers.html).

**SAMSUNG** harman/kardon®



Certification model only

### QUESTIONS OR COMMENTS?

COUNTRY	CALL	OR VISIT US ONLINE AT	WRITE
IN THE US	1-800-SAMSUNG (726-7864)	<a href="http://www.samsung.com/us/support">www.samsung.com/us/support</a>	Samsung Electronics America, Inc. 85 Challenger Road Ridgefield Park, NJ 07660

© 2019 Samsung Electronics Co., Ltd. All rights reserved.