

# **D-Link F-Series AI Enabled Network Cameras**

## **User Manual**

**ISSUE**

**v1.1**

**DATE**

**2022-04-11**



# About This Document

---

## Purpose

This document describes how to use the web management system, including network access, network configuration, and troubleshooting.





## Intended Audience

This document is intended for:

- Technical support engineers
- Maintenance engineers
- IP camera operators

## Symbol Conventions

The symbols that may be found in this document are defined as follows.

Symbol	Description
 <b>DANGER</b>	Indicates an imminently hazardous situation which, if not avoided, will result in death or serious injury.
 <b>WARNING</b>	Indicates a potentially hazardous situation which, if not avoided, could result in death or serious injury.
 <b>CAUTION</b>	Indicates a potentially hazardous situation which, if not avoided, may result in minor or moderate injury.
 <b>NOTICE</b>	Indicates a potentially hazardous situation which, if not avoided, could result in equipment damage, data loss, performance deterioration, or unanticipated results. NOTICE is used to address practices not related to personal injury.
 <b>NOTE</b>	Calls attention to important information, best practices and tips. NOTE is used to address information not related to personal injury, equipment damage, and environmental deterioration.

## Special Announcement

This manual may contain misprints, technology information that is not accurate enough, and description of product function and operation that is slightly inconsistent with the actual product. The manufacturer will update this manual according to product function enhancement or changes and regularly update the software and hardware described in this manual. Updated information will be added to new versions of this manual without prior notice.

This manual is only for reference. There may be slight difference between different models. Please refer to the actual products.

# Contents

---

<b>About This Document</b> .....	<b>i</b>
<b>Contents</b> .....	<b>ii</b>
<b>1 Quick Start</b> .....	<b>1</b>
1.1 Login and Logout .....	1
1.2 Change the Password.....	2
1.3 View Real-Time Video.....	3
1.4 Main Page Layout.....	7
1.5 AI Interface (Only for Some Models).....	9
1.6 Playback .....	10
1.7 Personnel Count (Only for Some Models).....	12
<b>2 Sensor Setting</b> .....	<b>13</b>
2.1 Control and Configure the PTZ (Only for Some Models) .....	13
2.2 Sensor Setting .....	19
2.2.1 Access the Sensor Setting Interface .....	19
2.2.2 Mode.....	20
2.2.3 Image Setting.....	21
2.2.4 Scene Mode .....	22
2.2.5 Exposure .....	24
2.2.6 WB Setting .....	27
2.2.7 Noise Reduction .....	33
2.2.8 Enhance Image .....	35
2.2.9 Zoom Focus (Supplied for some model) .....	37
<b>3 Configure the Device</b> .....	<b>40</b>
3.1 Device Information.....	40
3.2 Video and Audio Stream.....	42
3.3 ROI Parameter .....	47
3.4 Snapshot .....	48
3.5 Local Network .....	49
3.6 Device Port.....	51
3.7 Date and Time.....	53
3.8 Camera.....	56
3.9 OSD .....	57
3.10 Microphone (Only for Some Models).....	59
3.11 Audio Output (Only for Some Models) .....	60
3.12 CVBS Function (Supplied for some models) .....	61
3.13 System Service .....	62
3.14 Video Denoise (Only for Some Models).....	63
3.15 Software Licenses.....	63
<b>4 Configure External Devices</b> .....	<b>65</b>
4.1 External PTZ Parameters(Only for Some Models).....	65

<b>5 Configure Intelligent Analysis.....</b>	<b>67</b>
5.1 Perimeter.....	67
5.2 Single Virtual Fence .....	70
5.3 Double Virtual Fences .....	72
5.4 Multiple Loiter.....	75
5.5 Converse.....	78
5.6 Personnel Count (Only for Some Models).....	81
<b>6 Configure the Alarm Function .....</b>	<b>85</b>
6.1 Alarm Output (Only for Some Models).....	85
6.2 Disk Alarm.....	87
6.3 Network Alarm .....	87
6.4 Day Night Switch Alarm .....	88
6.5 I/O Alarm Linkage (Only for Some Models).....	89
6.6 Motion Detection Alarm Linkage .....	91
6.7 Push Message .....	93
6.8 Audio Abnormal Detection (Only for Some Models).....	94
6.9 Sound Alarm Output (Only for Some Models).....	96
6.10 Flashlight Alarm Output (Only for Some Models) .....	97
<b>7 AI Multiobject .....</b>	<b>98</b>
7.1 AI Configuration.....	98
<b>8 Configure the Recording Function .....</b>	<b>100</b>
8.1 Record Policy .....	100
8.2 Record Directory .....	101
8.2.1 Configure the SD Card .....	103
<b>9 Configure the Privacy Mask Function .....</b>	<b>105</b>
<b>10 Configure the Network Service.....</b>	<b>107</b>
10.1 802.1x .....	107
10.2 DDNS .....	107
10.3 PPPoE.....	109
10.4 Port Mapping .....	110
10.5 SMTP.....	112
10.6 FTP .....	113
10.7 IP Filter .....	115
10.8 CGI Alarm Service Center.....	117
10.9 SNMP .....	119
10.10 QOS .....	122
10.11 Platform Access .....	123
<b>11 Privilege Manager .....</b>	<b>125</b>
11.1 Configure a User.....	125
<b>12 Configure Protocol Parameters.....</b>	<b>128</b>
12.1 Protocol Information.....	128
12.2 Security Authentication .....	129

12.3 CMS Configuration .....	129
12.4 Multicast Parameters .....	130
<b>13 Query Device Logs.....</b>	<b>133</b>
13.1 Query Operation Logs .....	133
13.2 Query Alarm Logs .....	134
13.3 Collect All Logs.....	136
<b>14 Maintain the Device .....</b>	<b>137</b>
14.1 Restart a Device.....	137
14.2 Auto Reboot.....	138
14.3 Update the Software Package .....	138
14.4 Restore Device to Factory Settings.....	139
14.5 Export / Inport Configuration .....	141
<b>15 Local Configuration.....</b>	<b>142</b>
<b>16 Troubleshooting.....</b>	<b>143</b>
<b>A Acronyms and Abbreviations.....</b>	<b>144</b>

# 1 Quick Start

---

## 1.1 Login and Logout



### CAUTION

You can access the camera's web interface through Chrome, Edge, Firefox browsers. However some additional security restrictions in your browser may make some functions to become unavailable.

---

### Login

Step 1 Open your Web Browser, enter the IP address of the IP camera in the address box, and press **Enter**.



### NOTE

The camera's default setting is to obtain IP address automatically (DHCP). If DHCP server is not present the camera will use 192.168.0.120 address.

You can find out what IP address was assigned to the camera by checking your router's DHCP status or by running the *Tool for Cameras and NVR* software (downloadable from D-Link Web site).

The login page is displayed, as shown in Figure 1-1.

Figure 1-1 Login page

The screenshot shows a light blue login form. It contains two input fields: 'User Name' with the text 'admin' and 'Password' with five black dots. To the right of these fields is a blue button labeled 'Login'.

Step 2 Enter the user name and password.



### NOTE

- The default user name is **admin**. The default password is **admin**.
- Please change the password to ensure system security at the first login.
- It is advised to restart the device three minutes later after modifying password

Step 3 Click Login to enter the interface.

The main page is displayed.

### Logout

Click  in the upper right to return to login page.

# 1.2 Change the Password

## Description

For the first login, the change default password page is as shown in Figure 1-2.

Figure 1-2 Change the default password page

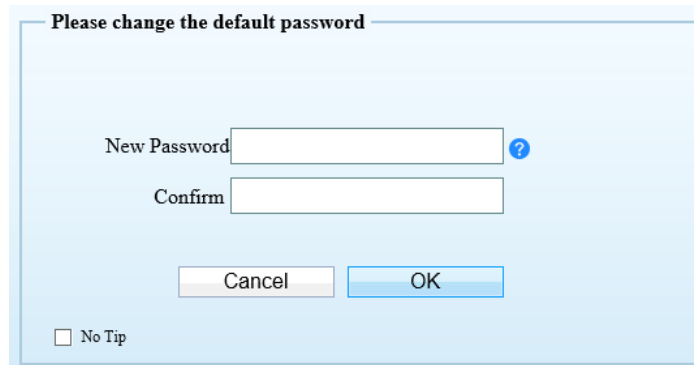

Or click  to change the password to login the system, as show in Figure 1-3.

Figure 1-3 Change password dialog box



## Procedure

Step 1 Input the old password, new password, and confirmation password.

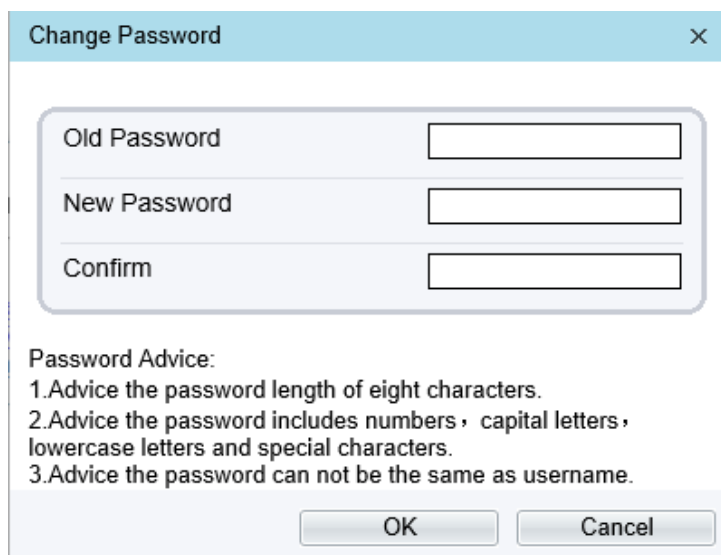
Step 2 Click **OK**.

If the message "Change own password success" pops up, the password is successfully changed. If the password fails to be changed, the password advice is displayed. (For example, the new password length couldn't be less than eight.).

It is advised to restarted the device three minutes later after modifying password.

Step 3 Click **OK**.

The login page is displayed.

## 1.3 View Real-Time Video

Your browser should display real-time video from your camera in MJPEG format. This video compression format is used for web interface to ensure compatibility with Web browsers and does not fully reflect the quality of the video stream coming from the camera.

### Select the play mode

If your Web browser does not support MJPEG format you may be prompted to install a plugin. You can select VLC player to play the video, or select the plugin to play the video as shown in **Error! Reference source not found.** when you login to the web management system for the first time.

Figure 1-4 Download the plugin page

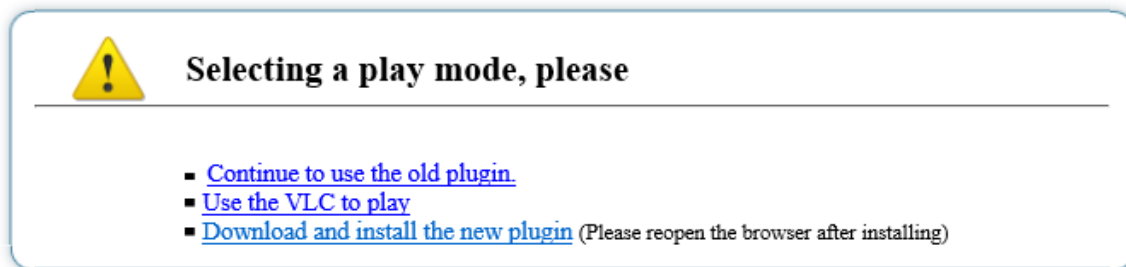

If plugin is selected, please install player control at first.

Step 1 Click “download and install the new plugin”, download the plugin as shown in Figure 1-55.

Figure 1-5 Run the plugin

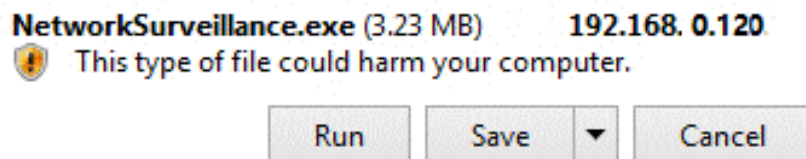

Step 2 Click "Run", select destination location as shown in Figure 1-66.

Figure 1-6 Select destination location

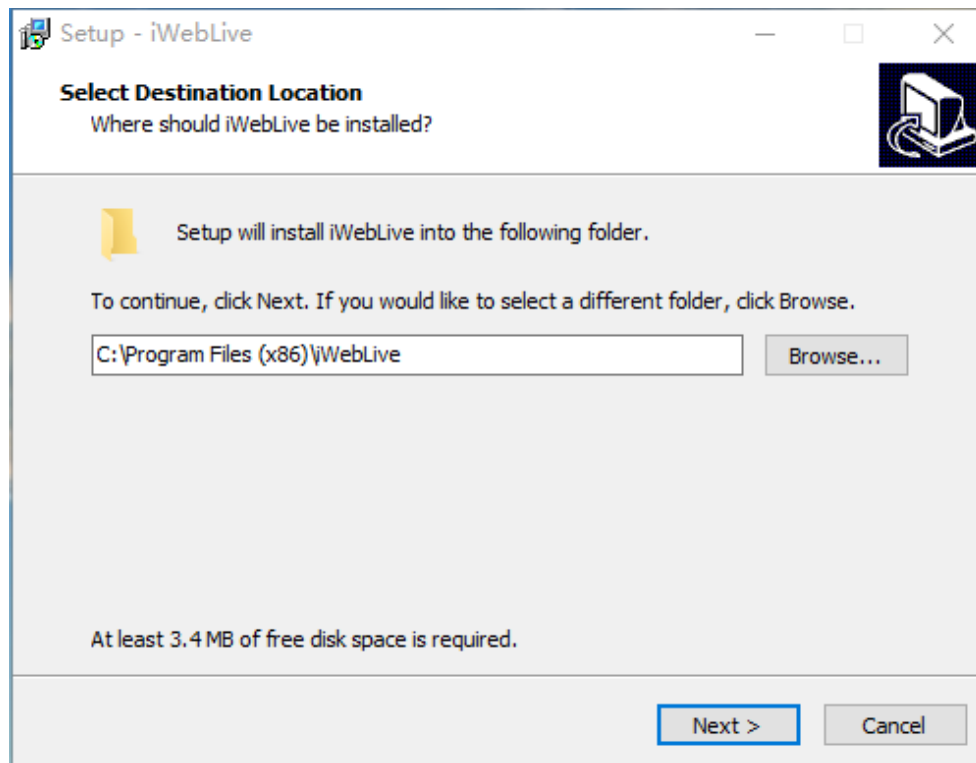

Step 3 Click "Next", ready to install the plugin, as shown in Figure 1-77.

Figure 1-7 Ready to install

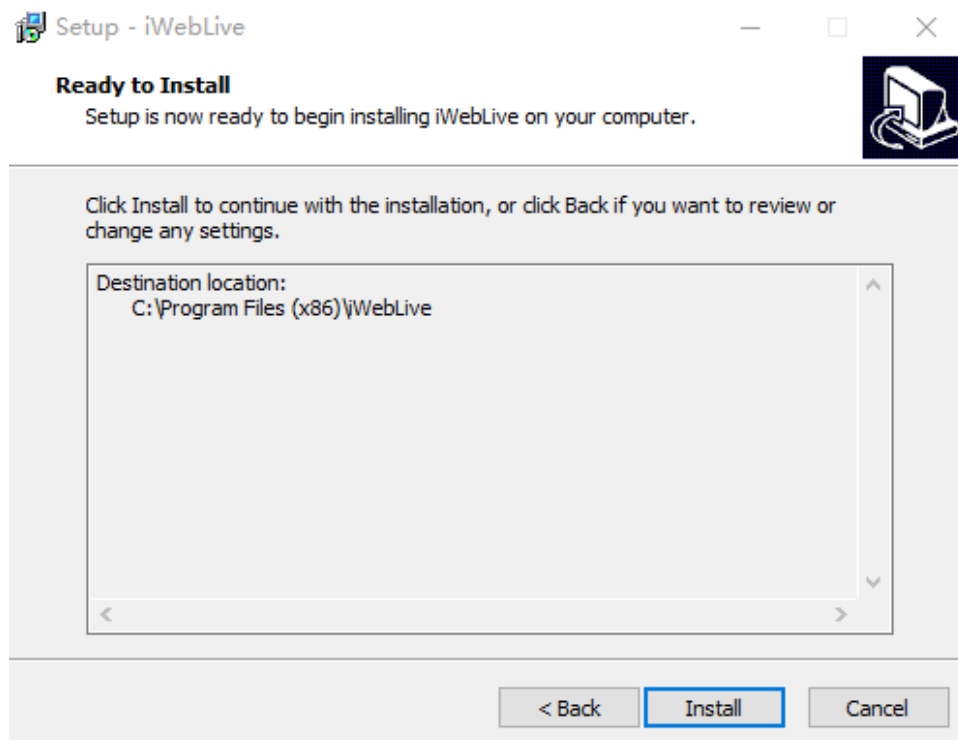

Step 4 Click “Install” to install the plugin, as shown in Figure 1-88.

Figure 1-8 Installing

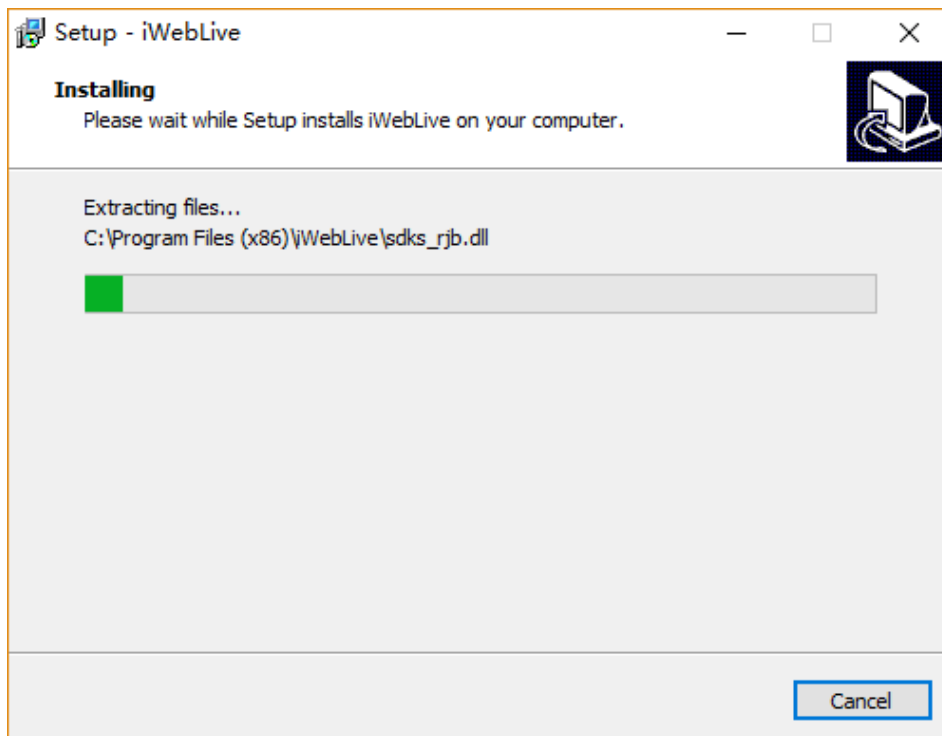

Step 5 Click “Finish” to complete the plugin installation, as shown in Figure 1-99.

Figure 1-9 Complete to install the plugin

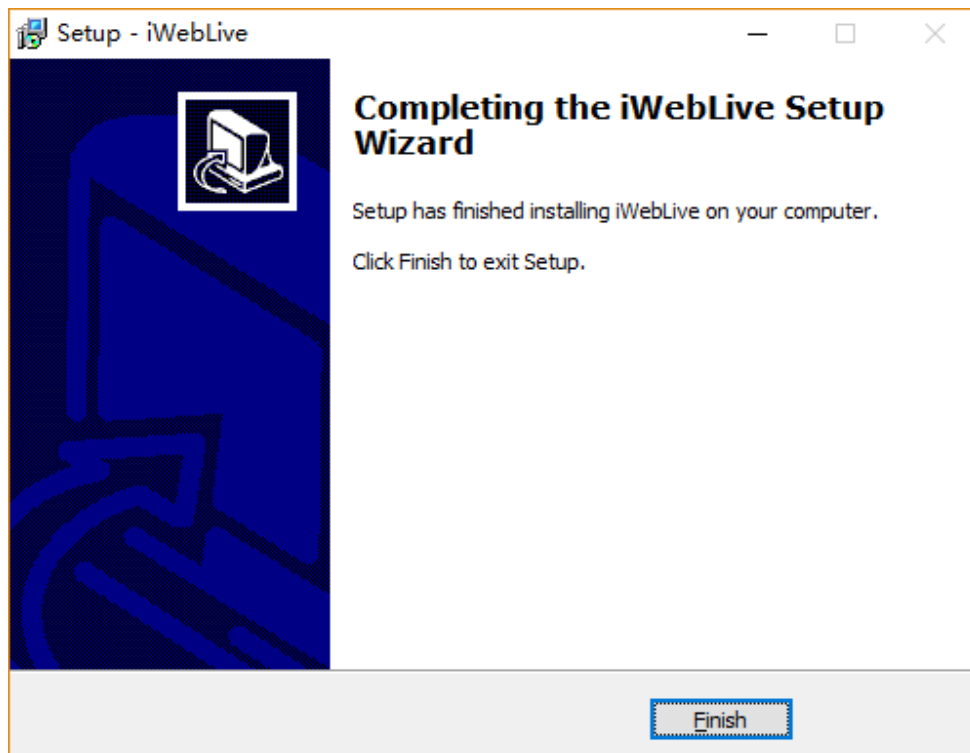

Step 6 Reopen the browser after installing.

 **NOTE**

- If the repair tips displayed when installing the control , please ignore the prompt, and continue the installation.
- During installing the plugin, the browser should be closed.



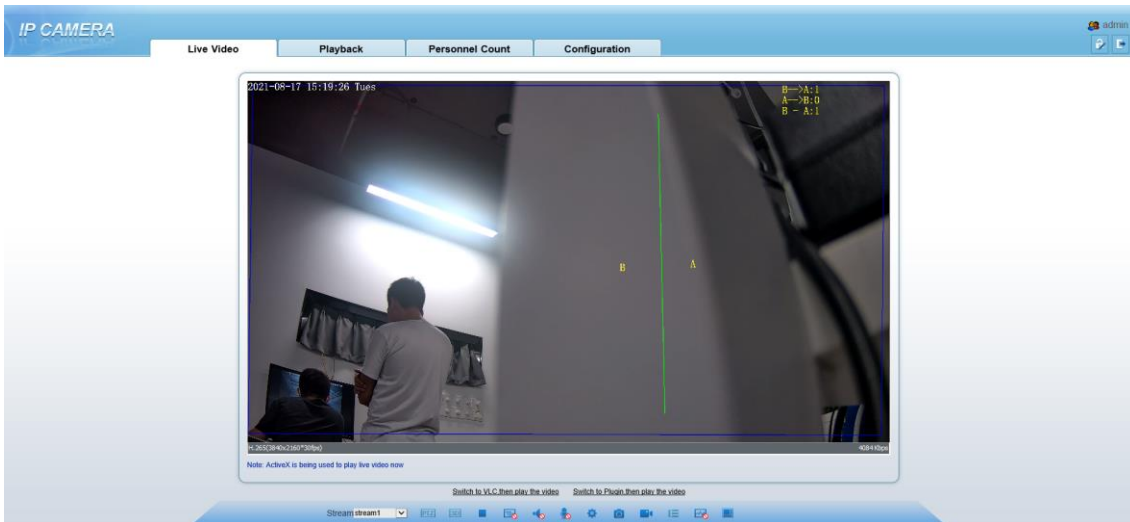

## Description

To view real-time video, click **Live Video**. The **Live Video** page is displayed, as shown in Figure 1-100.

Figure 1-10 Live Video page



On the **Live Video** page, you can perform the following operations:

- Click  to stop playing a video.
- Click  to play a video.
- Double-click in the video area to enter the full-screen mode, and double-click again to exit.
- Configure the PTZ. For details, see
- Configure the PTZ.
- Control the PTZ. For details, see Controlling the PTZ.
- Switch between three modes. For details about how to configure streams, see 3.2 Video and Audio Stream .
- Click  to switch the video to smooth mode.
- Click  to snapshot and save the photos.
- Click  to enable the local record.
- Configure the sensor.

You can right-click in the video area. A shortcut menu is displayed and allows you to enter the full-screen mode, set sensor parameters, zoom in or out, and return to the default view.

To set sensor parameters, click  to open the **Sensor Setting** page. On the **Sensor Setting** page, you can adjust the image, mirror, camera mode, focus setting, Iris setting, white balance, and noise filter as prompted.

Click  to show AI multi object live video, as shown in Figure 1-111.

Figure 1-11 AI multi object live video



Click “AI” icon to enter AI multiobject interface, as shown in Figure 1-11. The upper right of interface can switch face snapshot and license plate snapshot.

**NOTE**

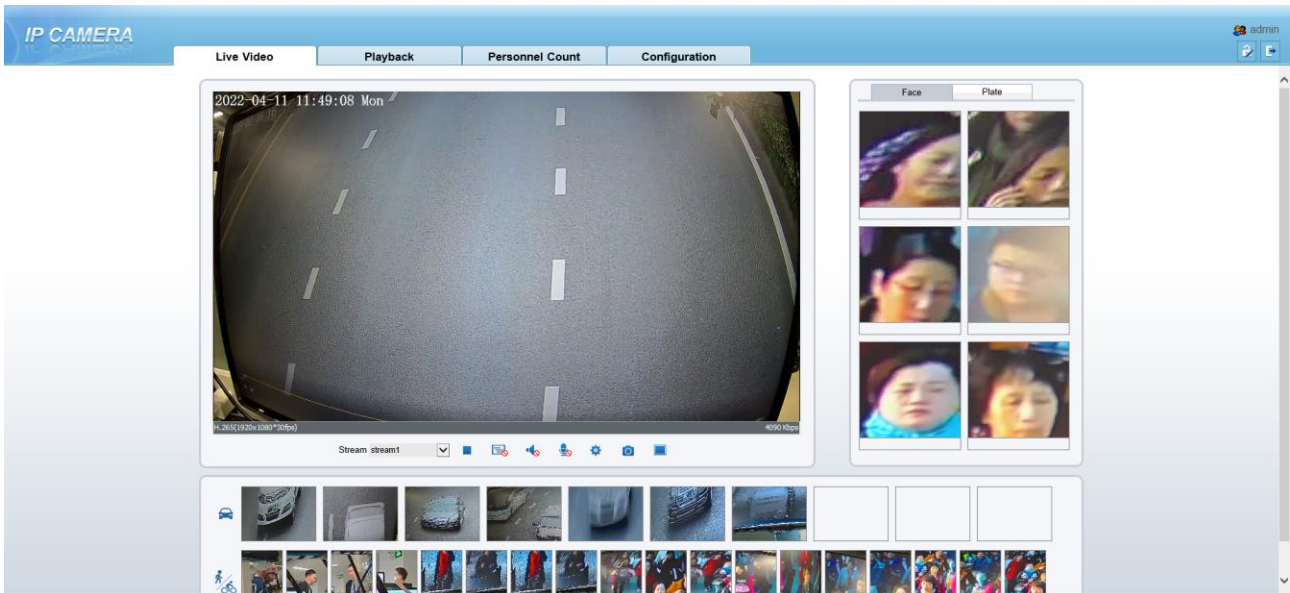
- AI interface is only available in some camera models.



## 1.4 Main Page Layout

On the main page, you can view real-time videos, receive alarm and fault notifications, set parameters, change the password, and log out of the system. Figure 1-122 shows the main page layout. Table 1-1 describes the elements on the main page.

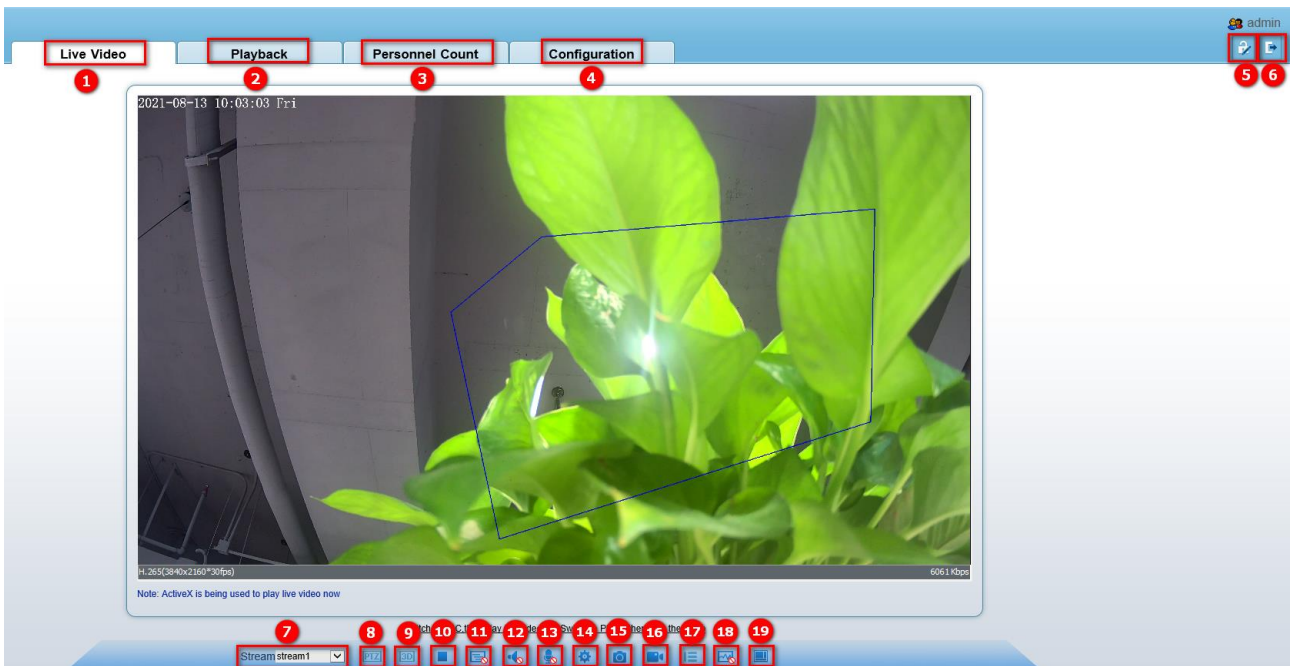
Figure 1-12 Main page layout







**Table 1-1** Elements on the main page

No.	Element	Description
1	Real-time video area	Real-time videos are played in this area. You can also set sensor parameters, right click on the real-time video display.
2	Playback	You can query the playback videos in this area. NOTE Only when the SD card or NAS has videos that you can query the playback videos.
3	Personnel count	Set the query condition to query the personnel count, the statistical can be shown in different types, such as line chart, histogram, list, for more detail information please refer to chapter 1.7 . Only for Some Models.
4	Device configuration	You can choose a menu to set device parameters, including the device information, audio and video streams, alarm setting, privacy mask function and so on.
5	Change password	You can click  to change the password.
6	Sign Out	You can click  to return to the login page.
7	Stream	Choose stream mode from drop-list. Set the parameters in " <b>Configuration &gt; Streams &gt; Basic Streams</b> ".
8	PTZ	Only used for dome cameras, set parameters. Only for Some Models.
9	3D	Only used for dome cameras, locate the exact location on the live video screen. Only for Some Models.
10	Pause/play	Pause the live video or play the video.
11	Live/smooth	Switch the resolution of live video automatically.
12	Audio	Open/close the audio.
13	Microphone	Open/close the microphone.
14	Sensor	Set the sensor parameters.
15	Snapshot	Click the icon to snapshot the video and save the images to the specified location.
16	Local record	Record the video and save the file to the specified location.
17	Mode	Only used for fisheye camera, click the icon to choose mode to play video.
18	Intelligent analysis	Open/close the intelligent analysis. Open the intelligent, choose the stream to stream 2, click to open the intelligent analysis, it will show target information and video stream draw line after you have turned on the function in IVS settings.

No.	Element	Description
19	AI live video	Click the icon to switch to AI live video, you can view the snapshots of AI multi object, there are face, plate, car, human body, riding, as shown in Figure 1-131. Only for Some Models.

 **NOTE**

- When the device accepts an alarm signal, the alarm icon will display within 10s in the web management system.  
The alarm icon  is displayed. You can click  to view the alarm information.
- When the device is abnormal, the fault icon  is displayed. You can click  to view the information.

## 1.5 AI Interface (Only for Some Models)

The AI cameras can capture specific targets, such as human face, license plate, ride bicycle, vehicle, and so on. Click  at live video interface, it will show AI interface as shown in Figure 1-133.



Figure 1-13 AI multi object interface

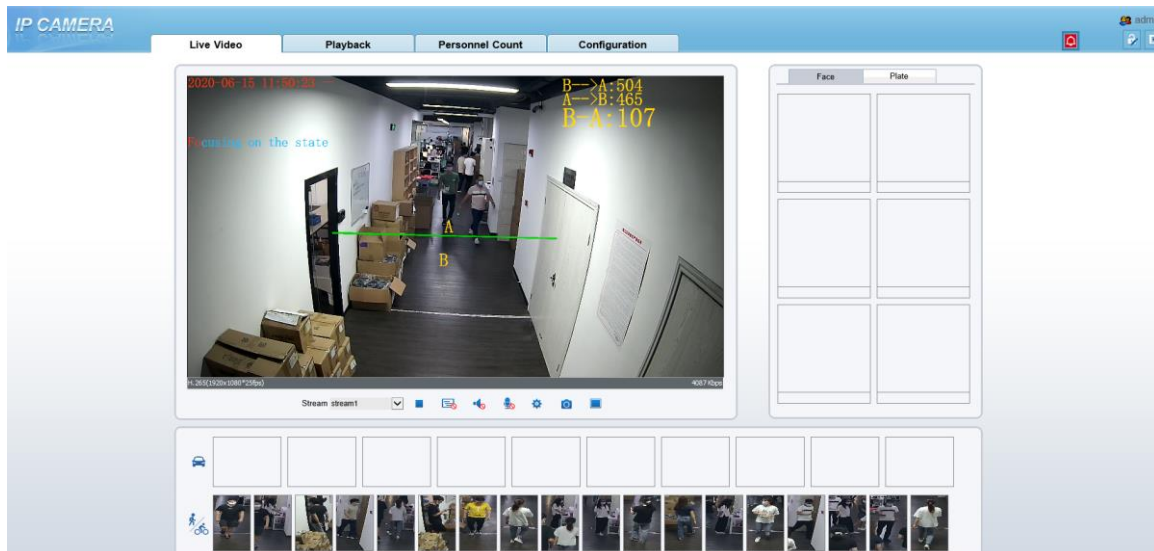

The face frame will show the snapshot of human face.  
The plate frame will show the snapshot of license plate.

 **NOTE**

The AI function is only available for some cameras.

## 1.6 Playback

Click “Playback” in camera’s web interface, if user install SD card, and there are video in SD card, click “Playback” and the playback video will show as in Figure 1-144.

Figure 1-14 Playback interface

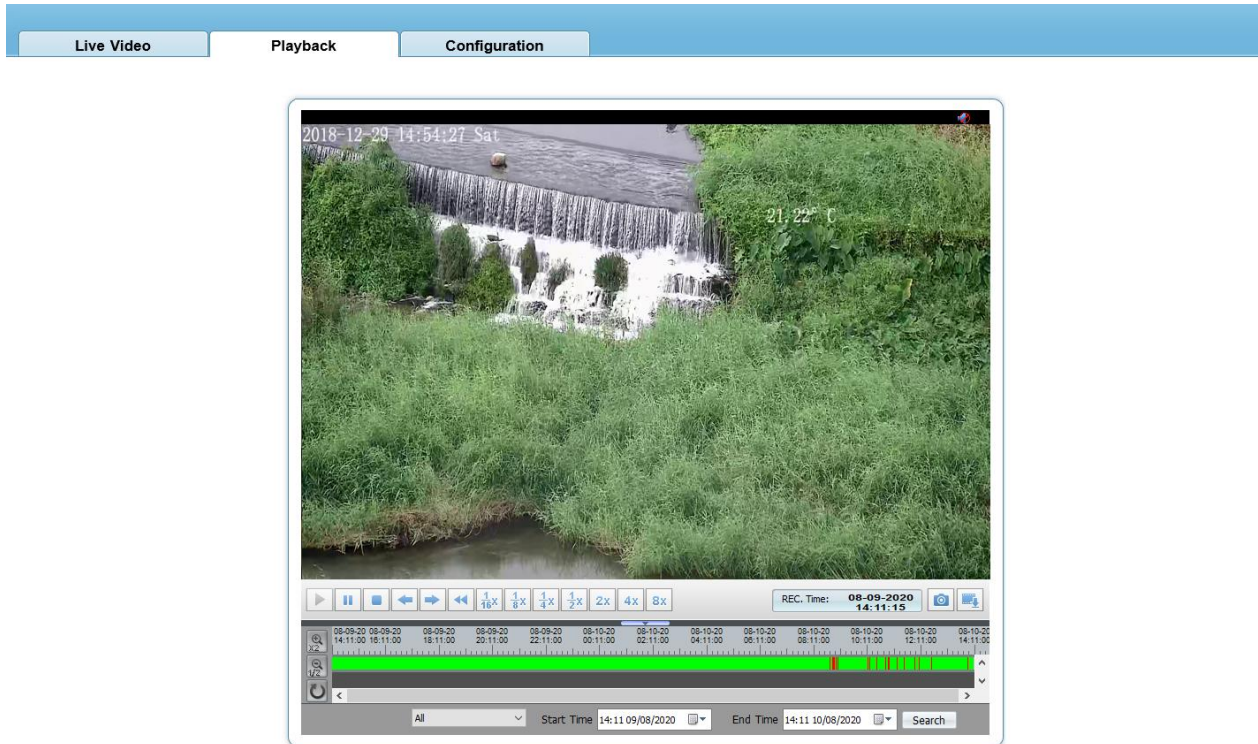

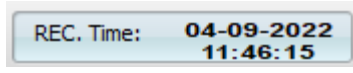

: Play, click “speaker” to switch sound on or off. The play time is shown

 and the blue line is pointing on timeline.

: Pause.

: Stop.

 : Frame back / frame play.

      : Fast forward, user can choose the different speed to play.

: Snapshot, click the icon to snapshot current interface

: Backup, use can view the status of backup, as shown in Figure 1-155.

Figure 1-15 Record backup



Drag the mouse to choose backup time, right-click to save, as shown in the figure.

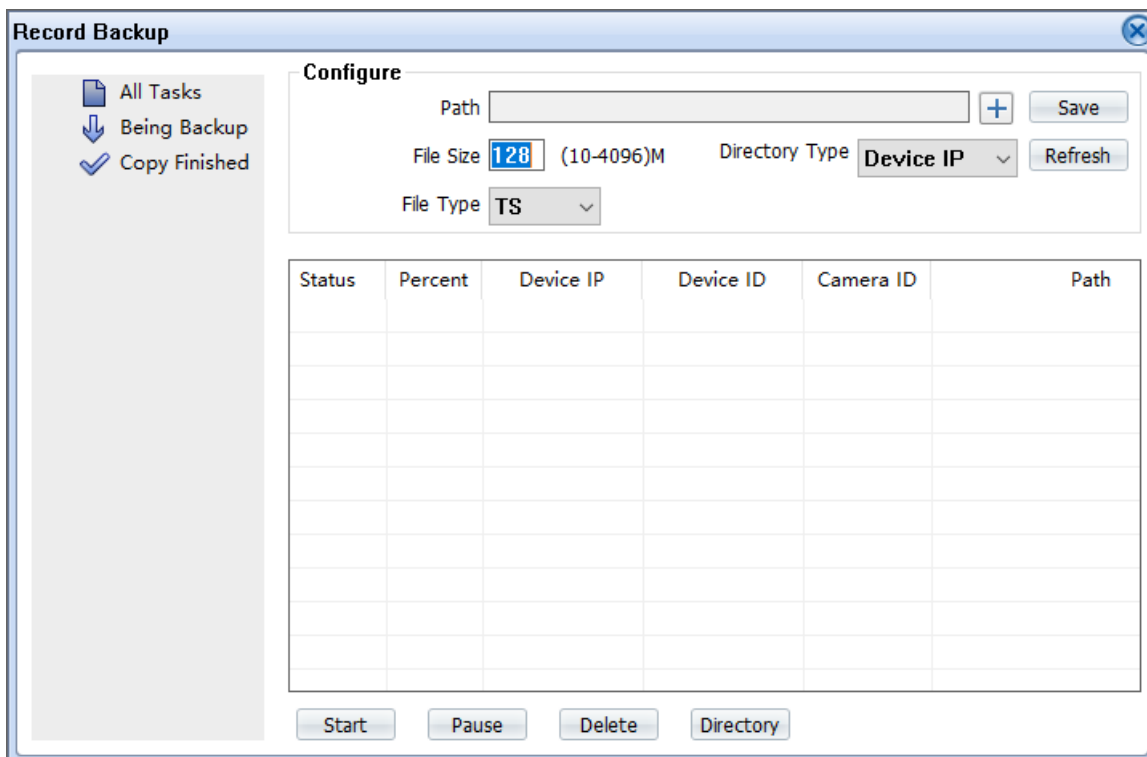
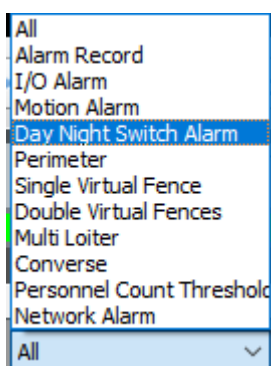
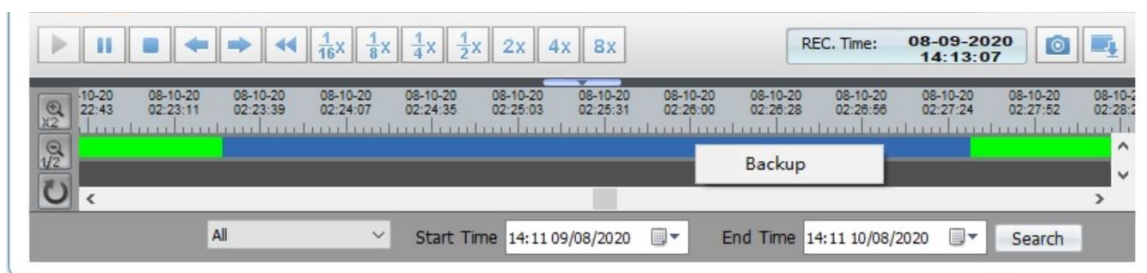

Choose the type of alarm, set the start time and end time to search alarm record quickly.

## 1.7 Personnel Count (Only for Some Models)

At **personnel count** interface, you can view the personnel count throughout setting query condition (choose the detail time at date's pop up window).

There are three modes to show the data, such as line chart, histogram, and list, as shown in Figure 1-166

Figure 1-16 Personnel count interface

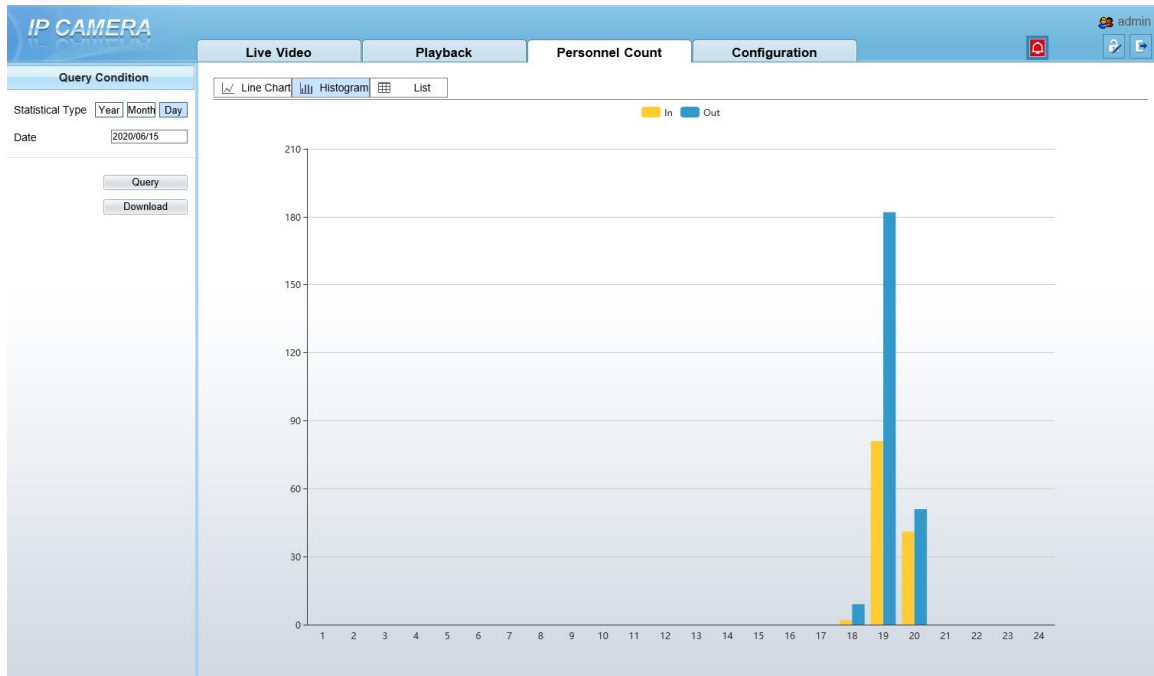

Click “Download” to download the query result.

Choose the mode of showing result, such as line chart, histogram and list.

Click “Query” to query the data of personnel count.

The data result can be saved to local folder.

# 2 Sensor Setting

## 2.1 Control and Configure the PTZ (Only for Some Models)

All PTZ functions are only available for High Speed Network Dome and device connected to an external PTZ. The focus and zoom action can be used for motorized cameras

### Controlling the PTZ







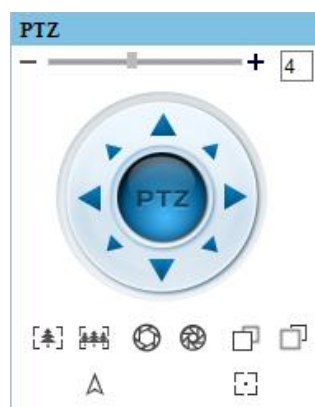

When browsing real-time videos shot by a dome camera or a camera connected to an external PTZ, you can control the PTZ to view videos shot in different directions.

Click **PTZ** below the **Live Video** page to open the **PTZ Control** page as shown in Figure 2-1, you can click the eight arrow keys to move the PTZ in eight directions. You can also zoom the lens and adjust the focal length.

Figure 2-1 PTZ Control area



In the PTZ control area, you can perform the following operations:

- Slide the slider left or right beyond the PTZ rotation keys, you can adjust the PTZ rotation speed.
- Click the arrows on the  to move the PTZ in eight directions.
- Click  or  to adjust the focal length.
- Click  or  to adjust the aperture.
- Click  or  to focus.
- Click  to set due north direction. You can define any direction as due north as the reference point of the PTZ rotation.
- Click  to enable automatic focus.

## Configure the PTZ

It is available for the cameras with PTZ or connected to PTZ. **PTZ Configure** interface is as shown in Figure 2-2.

Figure 2-2 PTZ Configure area

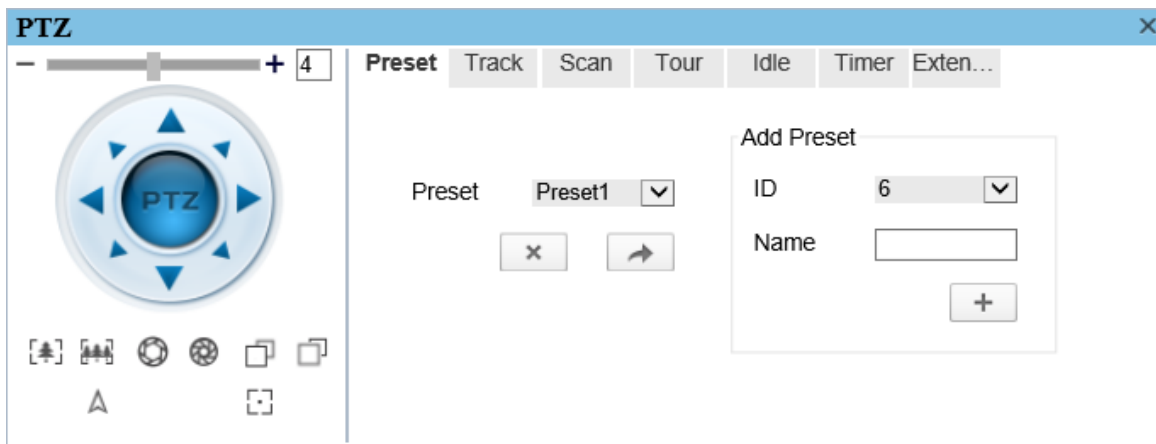

In the PTZ configure area, you can perform the following operations:

- Add, delete, and invoke preset positions.
- Add, delete, and invoke tracks.
- Add, delete, and invoke scans.
- Add, delete, and invoke tours.
- Set the idle.
- Set the timer.
- Set the extension.

Set Light On/Off and Brush function.

Brush is used to clean the lens. Light On/Off is used to control the infrared camera shields on and off.

### NOTE

- **Brush** is available only for a camera with a brush or a camera shield.
- **Light On/Off** is available only for specific camera shields.

## 3D Positioning

Click  below the Live Video page to configure the 3D positioning function.

The 3D positioning function quickly rotates the PTZ and changes the focal length in specific scenarios. You can also change the focus by drawing rectangle frames.

### NOTE

The default value of 3D Positioning is ON.

## Configure and Invoke Preset Positions

You can configure preset positions and quickly rotate the camera to a preset position by invoking the preset position.

The procedure is as follows:

Step 1 Configure a preset position.

1. Set the preset ID and name.
2. Click  to finish the preset position setting.



Step 2 Invoke a preset position.

Select a preset position from the **Preset** drop-down list box to invoke the preset position.

## Configure and Invoke Tracks

You can record a track to allow the camera to repeatedly rotate based on the preset track.

Step 1 Configure a track.

1. Set the track ID and name.
2. Click  to set the starting position of the track.
3. Use arrow keys in the **PTZ Control** area to set a required a track.
4. Click  to finish the track setting.

Step 2 Invoke a track.

Select a track name from the **Track** drop-down list box to invoke the track.

### NOTE

A maximum of six tracks can be configured.

## Configure and Invoke Scans

You can configure a starting point and end point to allow the camera to repeatedly rotate from the starting point to end point.

Step 1 Configure a scan.

1. Click **Scan**.

The **Scan Add** page is displayed as shown in Figure 2-3.

Figure 2-3 Scan configuration

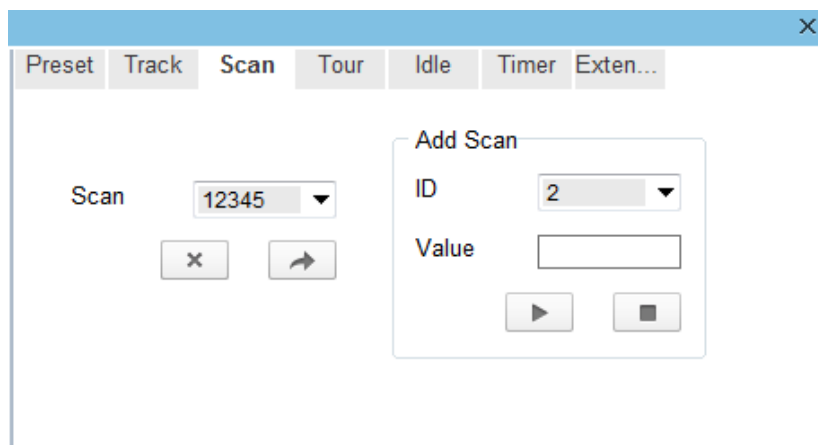

2. Set the scan ID and name.

3. Click .

- Use arrow keys in the **PTZ Control** area to set a start point and an end point.
- Click  to finish the scan setting.

Step 2 Invoke a scan.

Select a scan value from the **Scan** drop-down list box to invoke the scan.

 **NOTE**

A maximum of twelve scans can be configured.

## Configure and Invoke Tours

You can configure a tour to allow the camera to repeatedly rotate based the tours. Each tour includes presets and wait time should be set.



Step 1 Configure a tour.

- Click **Tour**.

The **Tour Add** page is displayed as shown in Figure 2-4.

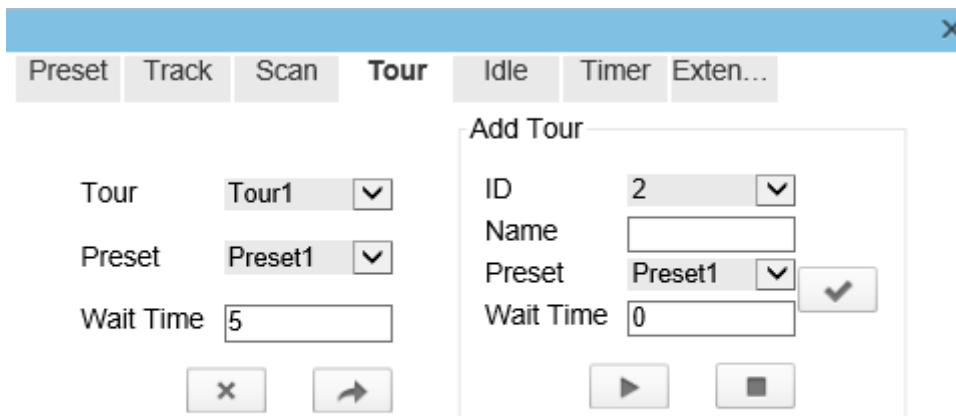
Figure 2-4 Tour configuration



- Set the tour ID and name.
- Select a preset and set the wait time and click .
- Continue to select a preset and set the wait time and click .
- Repeat the step 3 and step 4 to add more presets.
- Click  to finish the tour setting.

Step 2 Invoke a tour.

Select a tour value from the **tour** drop-down list box to invoke the tour.

 **NOTE**

A maximum of twelve tours can be configured.

## Configure Idles

You can enable idle to allow the camera to run the preset, track, scan and tour automatically after the waiting time (1 minute ~ 240 minutes).

Step 1 Click **Idle**.

The **Idle Add** page is displayed as shown in Figure 2-5.

Figure 2-5 Idle configuration

Enable

Type

Name

Wait Time

Step 2 Enable the Idle button.

Step 3 Set the idle type and name from the drop-down list box.

Step 4 Set the wait time(1 min ~240 min ).

Step 5 Click  to finish the idle setting.

## Configure Timer

You can set the PTZ timer to allow the camera to invoke the preset, track, scan and tour automatically in the setting time and the camera will restore to the operation and location after the end time.

Step 1 Click **Timer**.

The **Set the PTZ Timer** page is displayed and click , the **Timer** page is displayed as shown in Figure 2-6.

Figure 2-6 Timer configuration

Enable

Timer Mode  Everyday  Once Time

Timer	Begin Time	End Time	PTZ Type	Name	Clear
1	0:30				<input type="button" value="X"/>
2					<input type="button" value="X"/>
3					<input type="button" value="X"/>

Step 2 Enable Timer.

Step 3 Set the Timer Mode. Timer mode includes Everyday and Once. You should set the time when once mode is selected.

Step 4 Choose Once, click Time to choose day from the pop-up calendar.

Step 5 Set Timers.

Select the begin time, end time, PTZ type and name from the drop-down list box.

 **NOTE**

- A maximum of eight timers can be configured.
- Click Clear to delete the setting.

Step 6 Click  to finish the timer setting.

## Configure Extension

You can set light On/Off, brush function and reboot action in extension page.

Click Extension, the **Extension** page is displayed as shown in Figure 2-7.

Figure 2-7 Extension

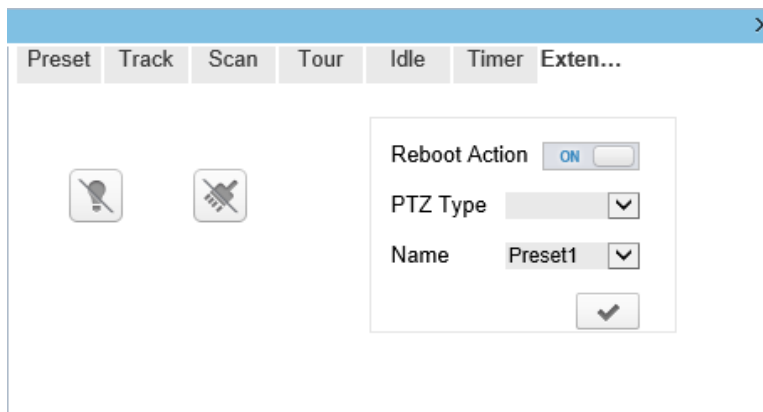

- Light function

Click  to enable the light.

Light On/Off is used to control the infrared camera shields on and off.

- Brush function

Click  to enable brush.

Brush is used to clean the lens.

 **NOTE**

- **Brush** is available only to a camera with a brush or a camera shield.
- **Light On/Off** is available only to specific camera shields.
- Reboot action

The camera will perform the selected PTZ type and name when the camera reboots and the reboot action is enabling.

- Click the reboot action button to enable reboot action
- Set the PTZ Type and name from the drop-down list box.
- Click  to finish the reboot setting.

## 2.2 Sensor Setting

### 2.2.1 Access the Sensor Setting Interface

#### Operation procedure:

- Step 1 On the web interface or client interface, move the cursor to the real-time video page and right-click. A shortcut menu is displayed, as shown in Figure 2-8. Or enter **Configuration > Sensor Setting** interface. Table 2-1 describes the sensor setting interface.

Figure 2-8 Sensor Setting interface

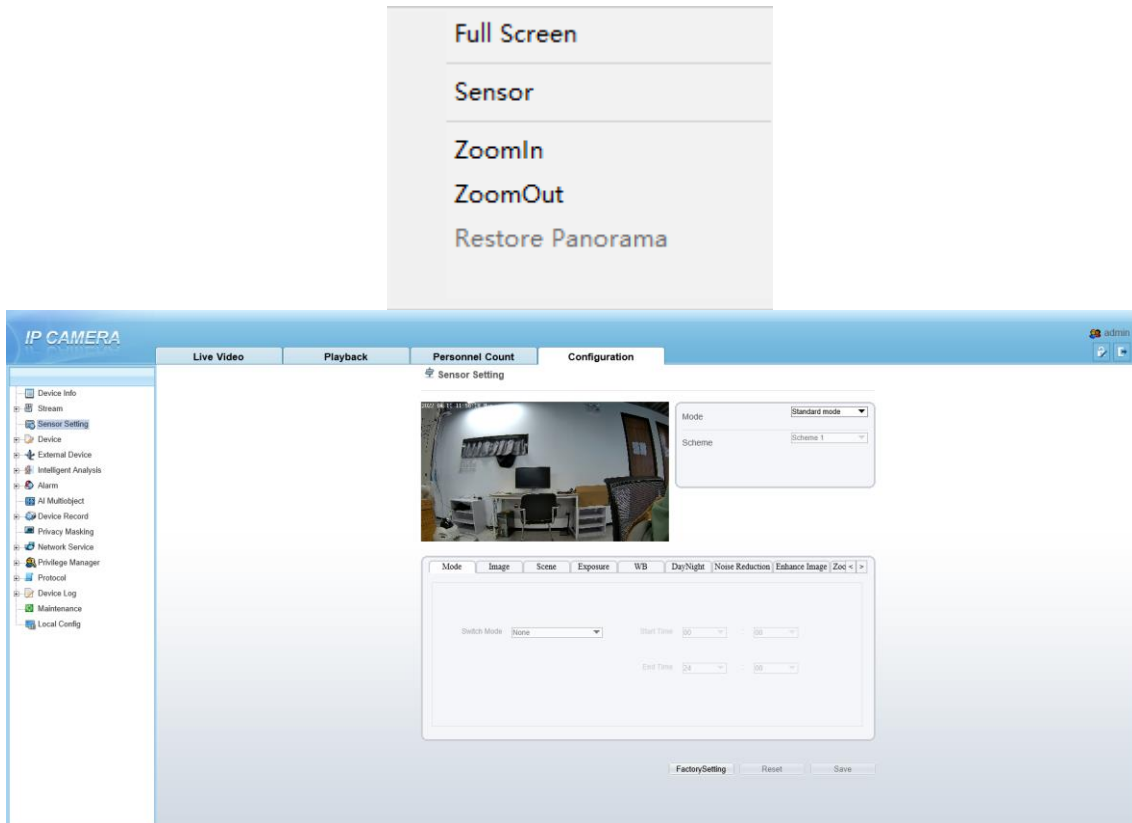

Table 2-1 Sensor parameters description

Parameter	Description
Full Screen	It enlarges and displays the image in full screen.
Sensor	It is used for configure the parameter set of front-end images.
Zoom In/Out	It zooms in/out images by electronic means. This function may also be used with the mouse wheel.
Restore Panorama	Only apply for screen is zooming, the default state is unavailable.

- Step 2 Choose **Sensor Configure** and the **Sensor Setting** dialog box appears.

## 2.2.2 Mode

### Operation procedure:

Step 1 Click **Mode** tag on sensor setting interface, the Mode page is displayed, as shown in Figure 2-9.

Figure 2-9 Mode page

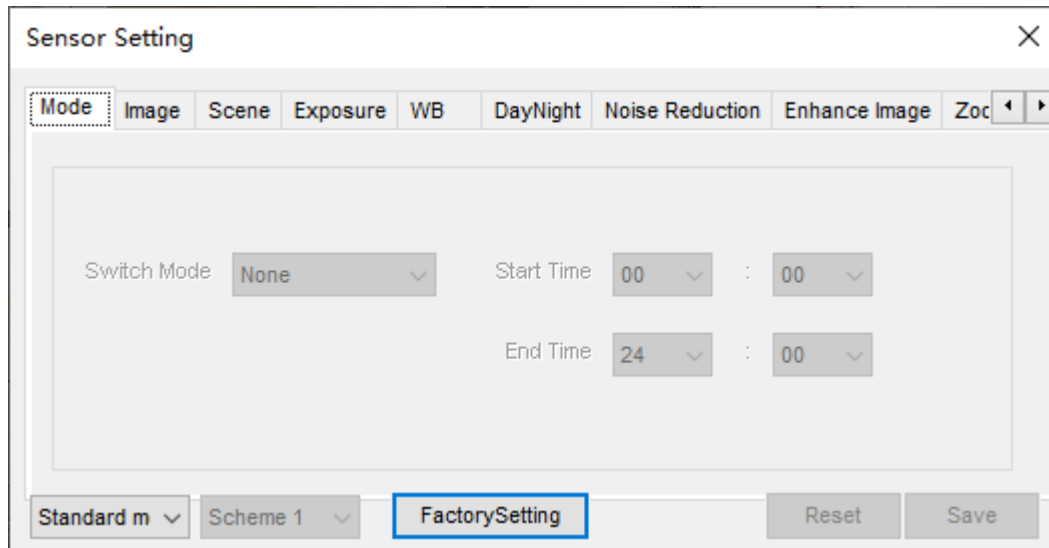

### Sensor Setting

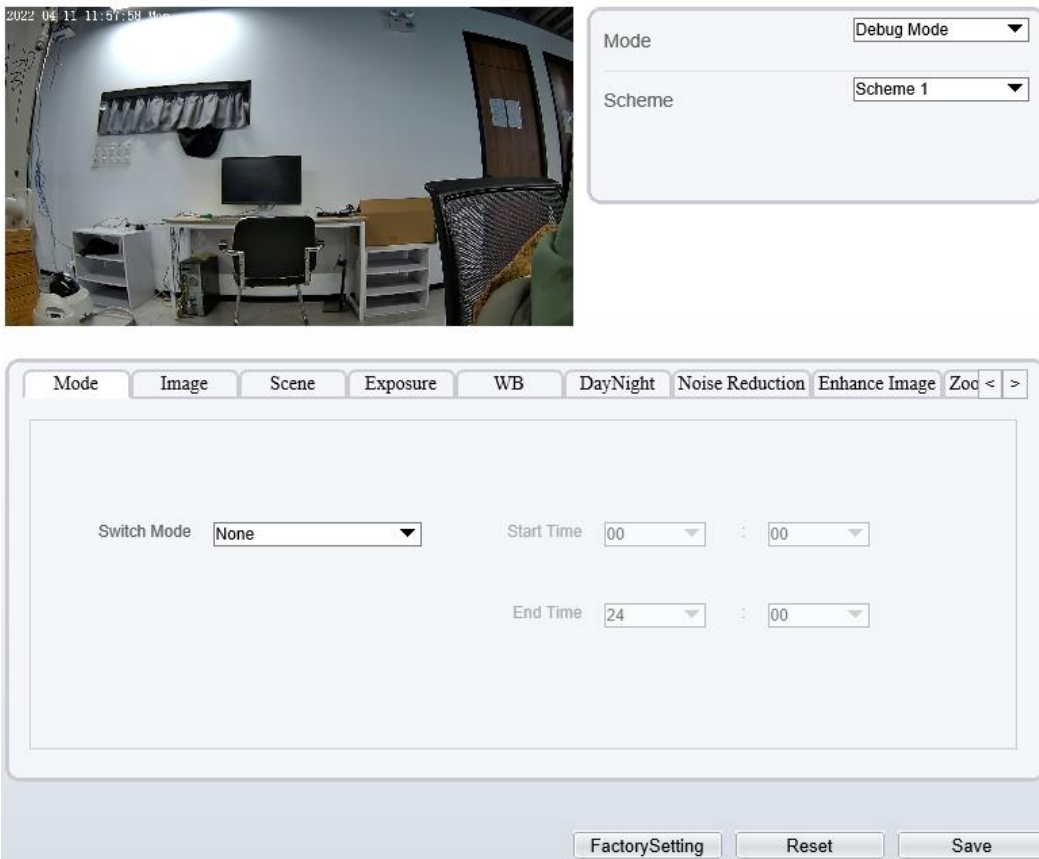

Step 2 Choose Debug Model in the lower left corner to activate the sensor setting page.

Step 3 Tick the Enable, then set the start time and end time.

Step 4 Click Save to save the setting.

## 2.2.3 Image Setting

Figure 2-10 shows the image setting interface.

Figure 2-10 Image setting interface

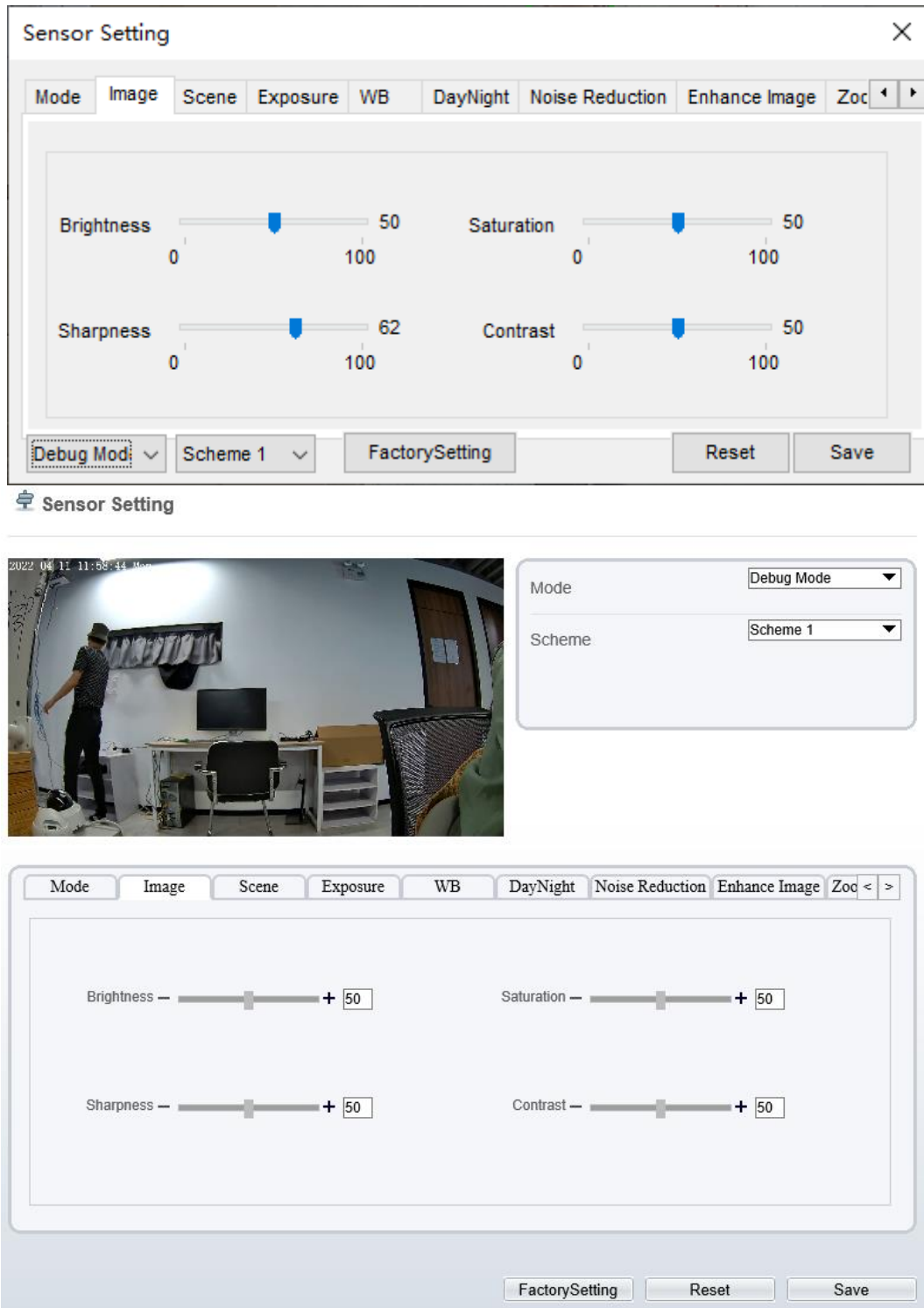

Table 2-2 describes the **image setting** parameters.

**Table 2-2** Image setting parameters description

Parameter	Description	Configuration Method
<b>Brightness</b>	It indicates the total brightness of an image. As the value increases, the image becomes brighter.	[Setting method] Drag the slider. [Default value] <b>50</b>
<b>Saturation</b>	It indicates the color saturation of an image. As the value increases, the image becomes more colorful.	[Setting method] Drag the slider. [Default value] <b>50</b>
<b>Sharpness</b>	It indicates the definition of an image. As the value increases, the image becomes more definitional.	[Setting method] Drag the slider. [Default value] <b>50</b>
<b>Contrast</b>	It indicates the contrast between the bright part and the dark part of an image. As the value increases, the contrast increases.	[Setting method] Drag the slider. [Default value] <b>50</b>

## 2.2.4 Scene Mode

Figure 2-11 shows the **scene mode** interface.

Figure 2-11 Scene mode interface for IP camera

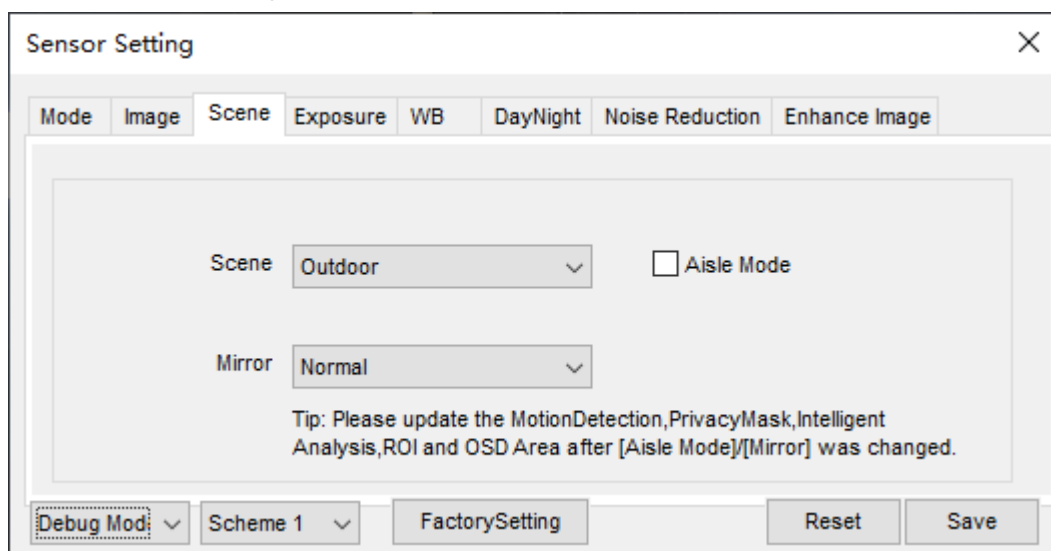

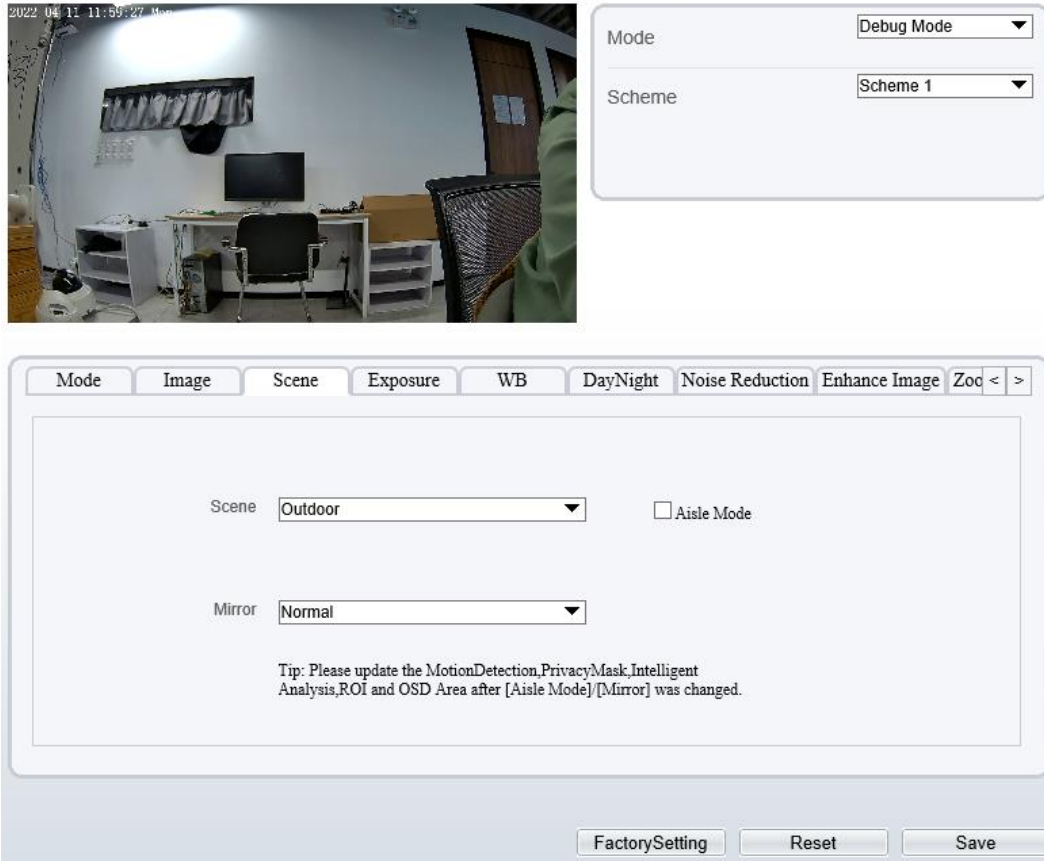

Table 2-3 describes the FFC mode parameters.

**Table 2-3** FFC mode parameters description

Parameter	Description	Configuration Method
<b>Scene</b>	<p>It indicates the working mode of a camera.</p> <ul style="list-style-type: none"> <li>Outdoor: It applies to outdoor scenarios.</li> <li>Indoor: It applies to indoor scenarios.</li> </ul>	<p>[Configuration method]</p> <p>Select from the drop-down list</p> <p>[Default value]</p> <p>Outdoor</p>
<b>Mirror</b>	<p>It is used to select the pixel location of an image.</p> <ul style="list-style-type: none"> <li>Normal: The image does not flip.</li> <li>Horizontal: The image flips to the left and right.</li> <li>Vertical: The image flips up and down.</li> <li>Horizontal and vertical: The image rotates at 180 degrees.</li> </ul>	<p>[Setting method]</p> <p>Select a value from the drop-down list.</p> <p>[Default value]</p> <p>Normal</p>
<b>Aisle Mode</b>	<p>The image rotates 90 degrees clockwise when aisle mode is enabled. For some models, when you choose stream 2 / 3, H.265 or H.264 video encode type, resolution chosen CIF or QVGA, it maybe not to play the live video.</p>	<p>[Setting method]</p> <p>Tick the Aisle mode.</p> <p>[Default value]</p> <p>Disable</p>

## 2.2.5 Exposure

Figure 2-12 and Figure 2-13 shows the **Exposure** interface.

Figure 2-12 Exposure interface for IP camera

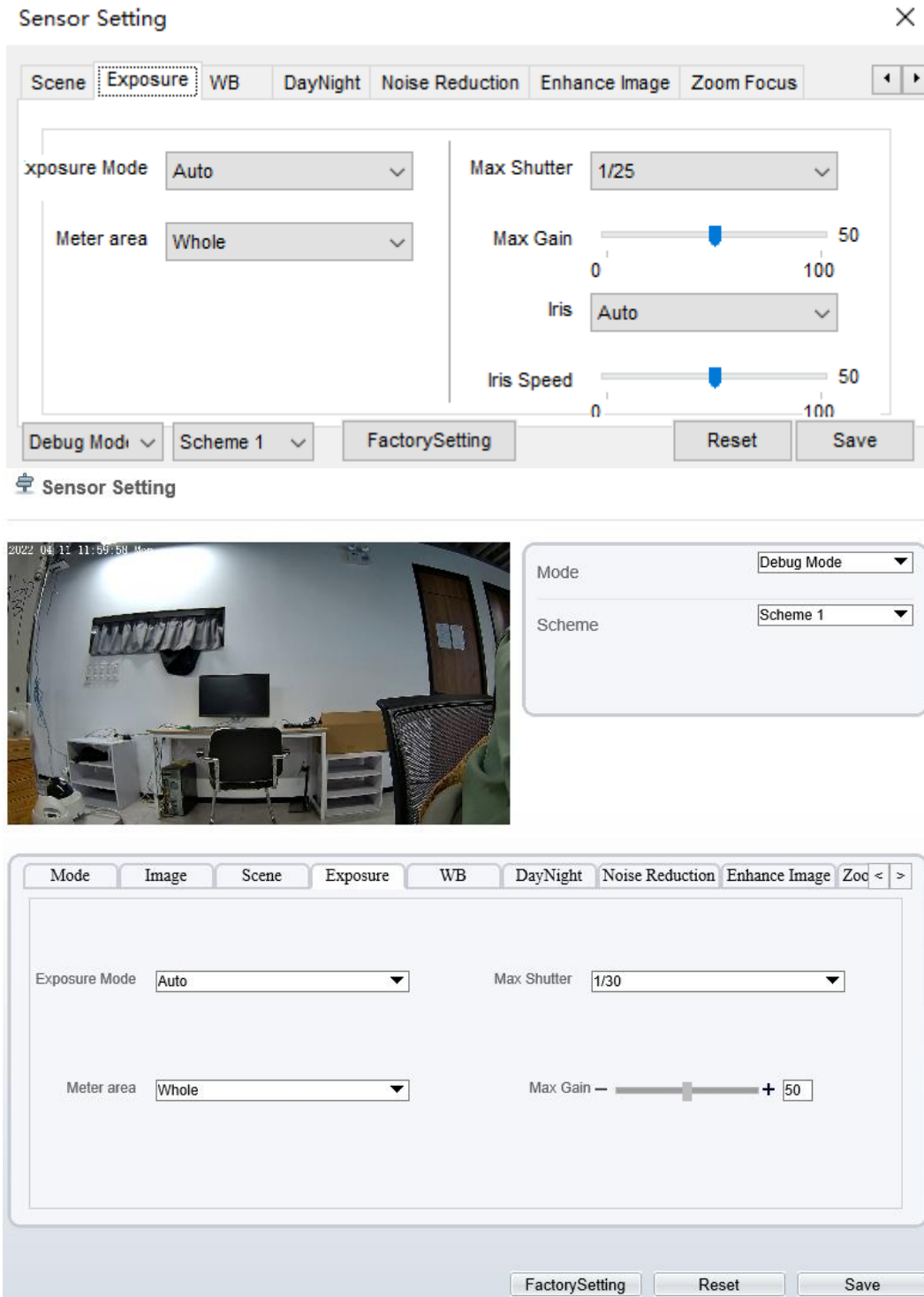

Figure 2-13 Exposure interface for high-speed dome

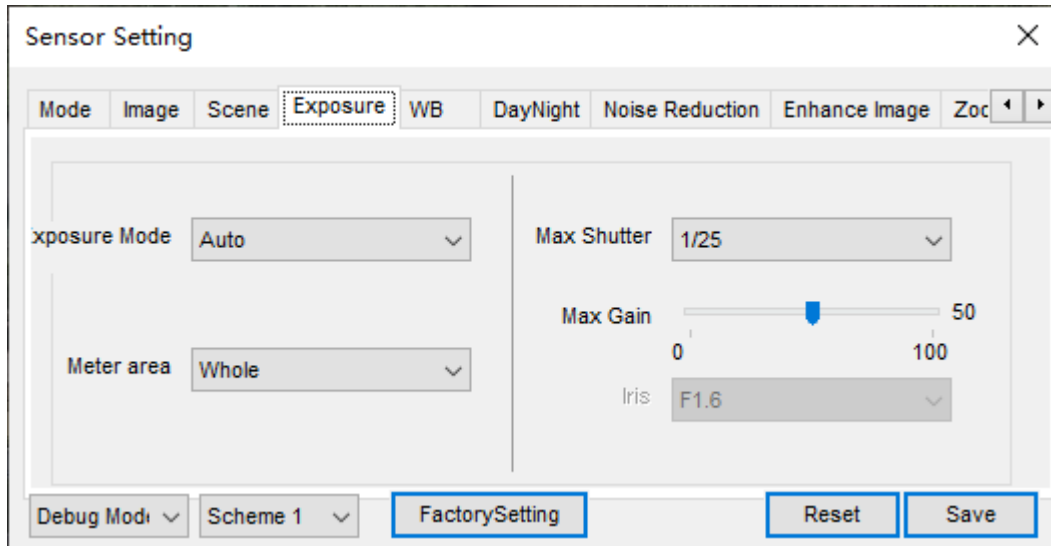



Table 2-4 describes Exposure parameters.

**Table 2-4** Exposure parameters description

Parameter	Meaning	Configuration Method
Exposure Mode	<p>The exposure modes include:</p> <ul style="list-style-type: none"> <li><b>Auto:</b> The system performs auto exposure based on the monitoring environment.</li> <li><b>Manual:</b> You can adjust the brightness of an image by setting the following three items: <b>Shutter Setting</b>, <b>Iris Setting</b> and <b>Gain Setting</b>.</li> <li><b>Shutter Priority:</b> You can set <b>Shutter Setting</b> to fixed values. The iris and gain are automatically adjusted by the system.</li> <li><b>Iris Priority (for high-speed dome):</b> You can set Iris Setting to fixed values. The shutter and gain are automatically adjusted by the system.</li> </ul>	<p>[Setting method] Select a value from the drop-down list. [Default value] <b>Auto</b></p>
Meter area	<p>It is used to select the metering area.</p> <ul style="list-style-type: none"> <li><b>Whole:</b> During metering, all areas of an image have an equal weight, that is, all areas are involved in the metering.</li> <li><b>Center spot:</b> During metering, the central spot of an image has the highest weight.</li> <li><b>Center Area:</b> During metering, the middle area (1/2 of the total area) of an image has the highest weight, and other areas have the lowest weight.</li> </ul>	<p>[Setting method] Select a value from the drop-down list. [Default value] <b>Whole</b></p>

Parameter	Meaning	Configuration Method
<b>Max Shutter</b>	The device automatically adjusts the shutter time based on the ambient brightness. The shutter time is less than or equal to the value of this parameter.	[Setting method] Select a value from the drop-down list. [Default value] <b>1/25</b>
<b>Max Gain</b>	The device automatically adjusts the gain based on the external light. The gain is less than or equal to the value of this parameter.	[Setting method] Drag the slider. [Default value] <b>50</b>
<b>Iris (for high speed dome)</b>	It is valid in manual mode and iris priority mode. You can adjust the brightness of an image by setting the iris. As the value increases, the brightness increases (when the shutter and gain remain the same). However, the camera movement automatically adjusts the shutter and gain in this mode. Therefore, the brightness of an image may not increase when you increase the iris.	[Setting method] Select a value from the drop-down list. [Default value] <b>F1.6</b>
<b>Iris (for IP camera)</b>	It is used to control the light admitted to the lens. The auto iris can be set to either of the following states: <ul style="list-style-type: none"> <li>• <b>Auto</b> The iris is automatically adjusted to control the light admitted to the lens.</li> <li>• <b>Open fully</b> The iris is fully open.</li> </ul>	[Setting method] Select a value from the drop-down list. [Default value] <b>Auto</b>
<b>Iris Speed</b>	It indicates the auto adjustment speed of the iris. As the value increases, the speed increases. Excessive speed may cause instability.  <b>NOTE</b> This parameter is valid when the auto iris is enabled.	[Setting method] Drag the slider. [Default value] <b>50</b>
<b>Fixed Gain</b>	When the exposure Mode is Manual, you can set the fixed gain.	[Setting method] Drag the slider. [Default value] <b>50</b>

## 2.2.6 WB Setting

Figure 2-14 shows the **WB Setting** interface.

Figure 2-14 **WB Setting** interface

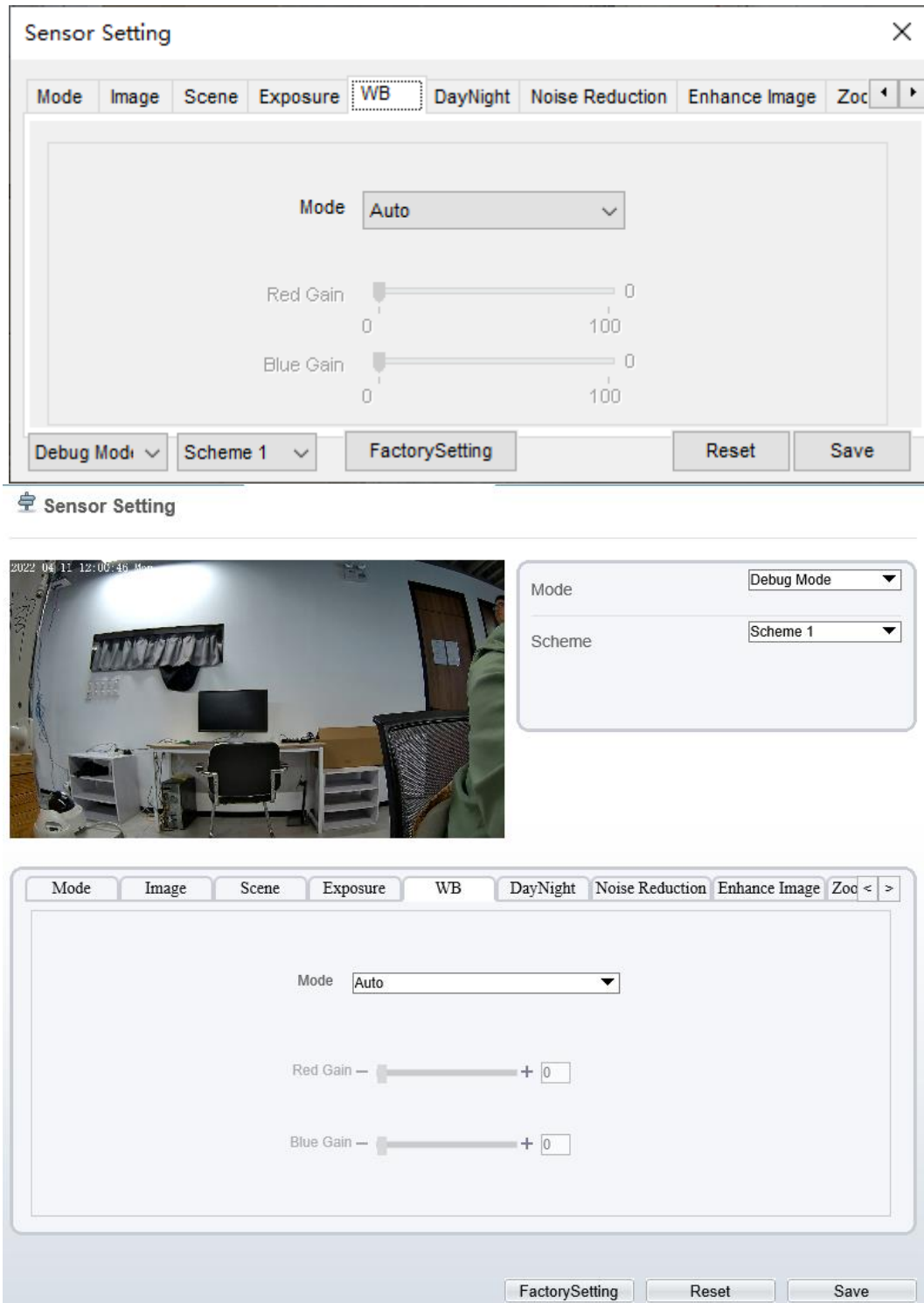



Table 2-5 describes **WB Setting** parameters.

**Table 2-5 WB Setting** parameters description

Parameter	Meaning	Configuration Method
<b>Mode</b>	<p>Select WB mode according to different scenes for better image color reproduction.</p> <ul style="list-style-type: none"> <li>• <b>Auto:</b> In automatic white balance (WB) mode, the system automatically performs white balance based on the monitoring environment.</li> <li>• <b>Tungsten</b></li> <li>• <b>Fluorescent</b></li> <li>• <b>Daylight</b></li> <li>• <b>Shadow</b></li> <li>• <b>Manual:</b> In manual WB mode, you can manually select a WB mode based on the monitoring environment.</li> </ul>	<p>[Setting method] Select a value from the drop-down list. [Default value] <b>Auto</b></p>
<b>Red Gain</b>	<p>It indicates the gain applied to red channels. As the value increases, the color temperature becomes lower.</p> <p> <b>NOTE</b> This parameter is valid when <b>Manual Mode</b> is set to <b>Customized</b>.</p>	<p>[Setting method] Drag the slider. [Default value] <b>0</b></p>
<b>Blue Gain</b>	<p>It indicates the gain applied to blue channels. As the value increases, the color temperature becomes higher.</p> <p> <b>NOTE</b> This parameter is valid when <b>Manual Mode</b> is set to <b>Customized</b>.</p>	<p>[Setting method] Drag the slider. [Default value] <b>0</b></p>

## Day/ Night Mode

The day/ night mode settings vary based on device models. For details, see the following sections.

Figure 2-15 to Figure 2-18 shows the **Day/ Night Mode** interface.

Figure 2-15 Day/ Night Mode (1) interface

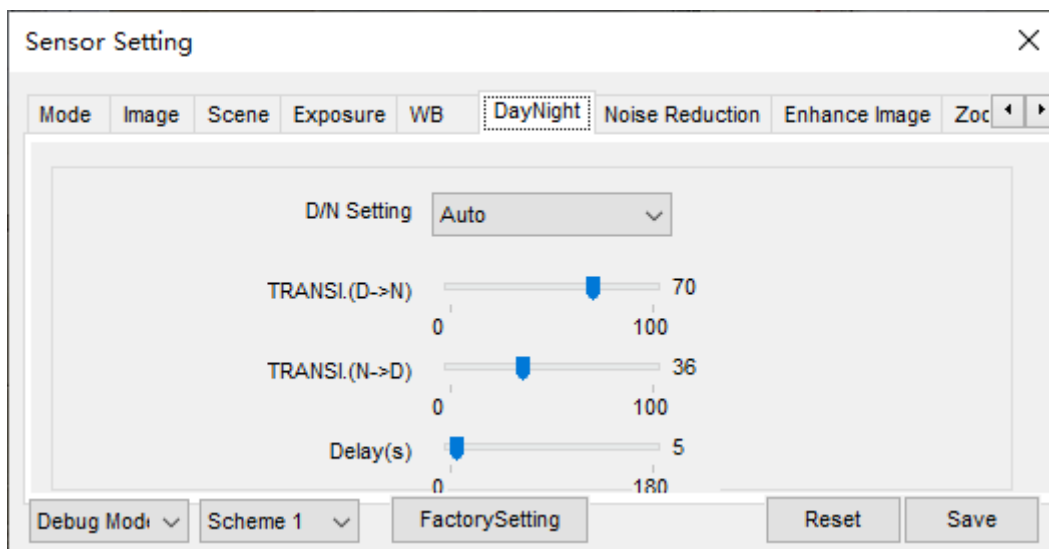

Sensor Setting

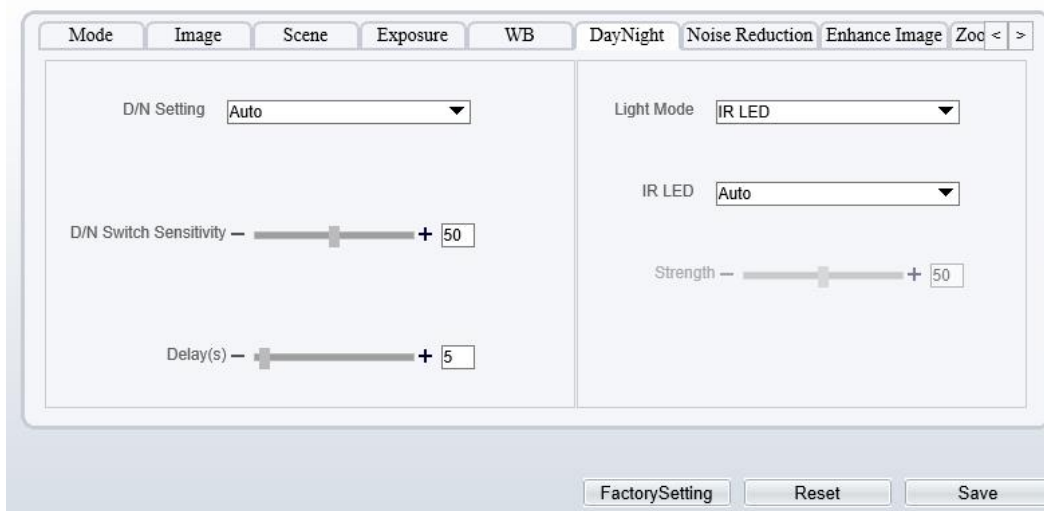
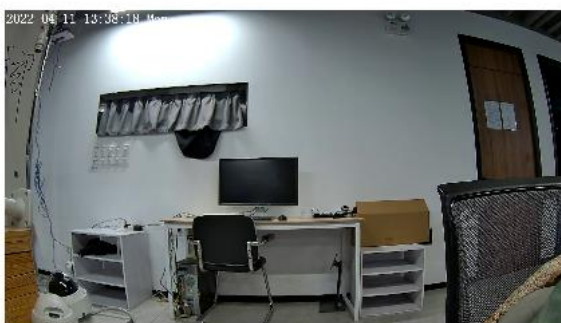

Figure 2-16 Day/ Night Mode (2) interface

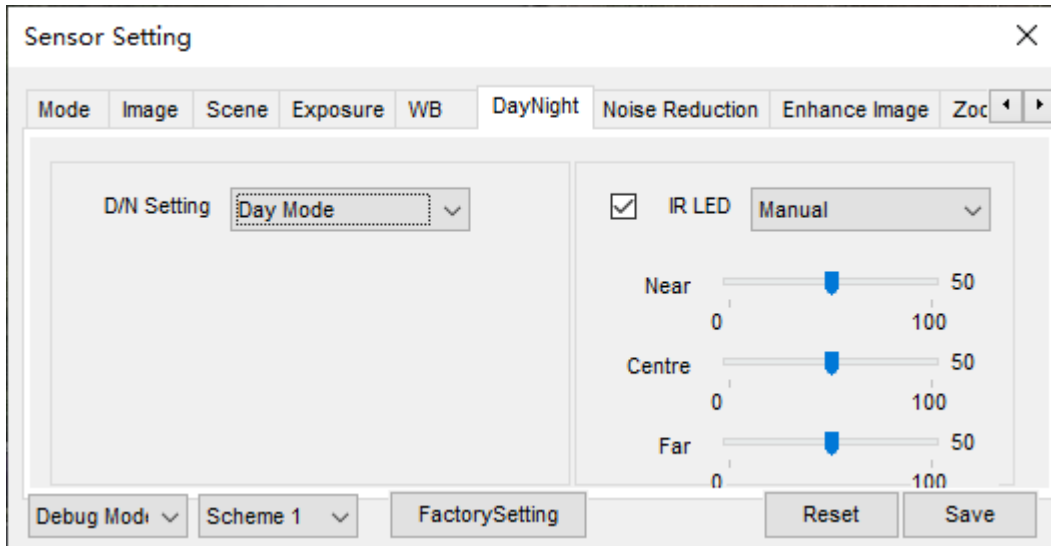

Figure 2-17 Day/ Night Mode (3) interface

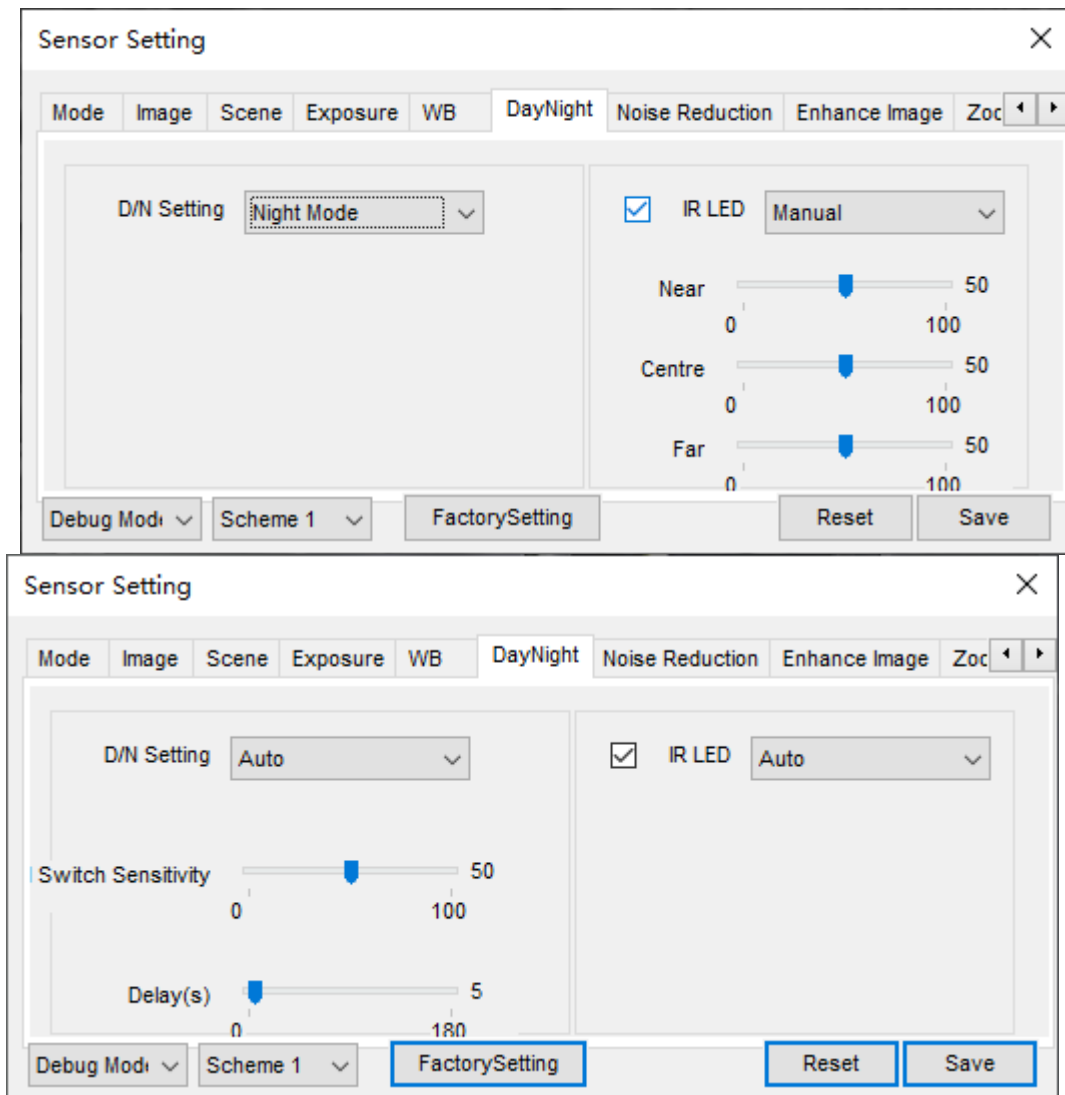

Figure 2-18 Day/ Night Mode (4) interface

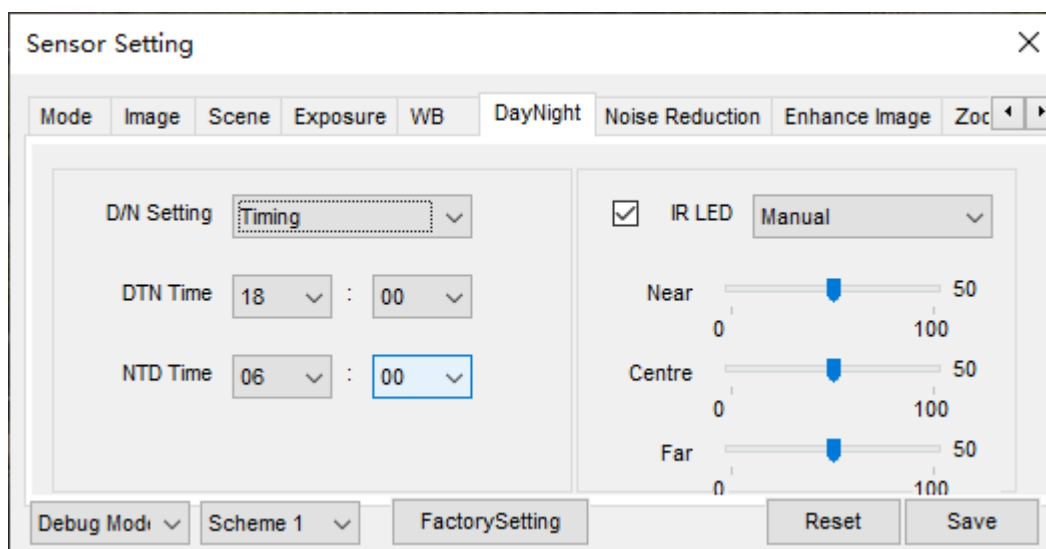







Table 2-6 describes Day/ Night Mode parameters.

Table 2-6 DNR parameters description

Parameter	Meaning	Configuration Method
<b>D/N Setting Mode</b>	<p>It can be set to <b>Auto</b>, <b>Day</b>, <b>Night</b> or <b>Timing</b>.</p> <ul style="list-style-type: none"> <li>• Auto mode The image color and filter status are automatically switched based on the ambient brightness. The filter keeps infrared light from reaching the sensor during the day; The filter allows all light to reach the sensor at night.</li> <li>• Day mode The image is colored, and the filter is in the day state, preventing infrared light from entering the sensor.</li> <li>• Night mode The image is black and white, and the filter is in the night state, allowing infrared light to enter the sensor.</li> <li>• Timing Switching between day mode and night mode according to the set time.</li> </ul>	<p>[Setting method] Select a value from the drop-down list. [Default value] <b>Auto</b></p>
<b>Switch Sensitivity</b>	<p>The sensitivity of switching day and night. The higher value of sensitivity, and the lower light intensity will switch to day.</p> <p> <b>NOTE</b> This parameter is valid in auto mode.</p>	<p>[Setting method] Drag the slider. [Default value] <b>50</b></p>

Parameter	Meaning	Configuration Method
<b>TRANSI. (D-&gt;N) (dB)</b>	<p>It determines the day-to-night switching in auto mode. When the system gain is greater than the value of this parameter, the system enters the night mode.</p> <p> <b>NOTE</b> This parameter is valid in auto mode. The value of <b>TRANSI. (D-&gt;N)</b> must be greater than the value of <b>TRANSI. (N-&gt;D)</b>.</p>	<p>[Setting method] Drag the slider. [Default value] <b>70</b></p>
<b>TRANSI. (N-&gt;D) (dB)</b>	<p>It determines the night-to-day switching in auto mode. When the system gain is smaller than the value of this parameter, the system enters the day mode.</p> <p> <b>NOTE</b> This parameter is valid in auto mode. The value of <b>TRANSI.(D-&gt;N)</b> must be greater than the value of <b>TRANSI.(N-&gt;D)</b>.</p>	<p>[Setting method] Drag the slider. [Default value] <b>30</b></p>
<b>Delay(s)</b>	<p>The delay time of day to night or night to day.</p> <p> <b>NOTE</b> This parameter is valid in auto mode.</p>	<p>[Setting method] Drag the slider. [Default value] <b>0</b></p>
<b>IR LED</b>	<ul style="list-style-type: none"> <li>• <b>Auto:</b> The infrared lamp is enabled or disabled based on the external environment identified by the light dependent resistor (LDR).</li> <li>• <b>ON:</b> The system enters the night mode forcibly.</li> <li>• <b>OFF:</b> The infrared lamp is disabled. The filter and image color are switched based on the external environment identified by the LDR.</li> </ul> <p> <b>NOTE</b> This parameter is valid in auto mode.</p>	<p>[Setting method] Select a value from the drop-down list. [Default value] <b>Auto</b></p>
<b>Strength</b>	<p>Strength of IR LED, as the value increases, the image becomes brighter.</p>	<p>[Setting method] Drag the slider. [Default value] <b>50</b></p>
<b>DTN Time</b>	<p>Time of day to night.</p>	<p>[Setting method] Select a value from the drop-down list. [Default value] <b>18:00</b></p>
<b>NTD Time</b>	<p>Time of night to day.</p>	<p>[Setting method] Select a value from the drop-down list. [Default value] <b>6:00</b></p>

## Fill light settings

The camera fill light has four modes, there are intelligent dual light (the current fill light will switch to warm light after an alarm is triggered, and switch back to the original fill light for fill light 30s after the alert is released.), warm light, infrared lamp and close (Choose to close the fill light and the color of image will stay in the previous mode).

The different camera can be set different fill light modes, please set according to the actual scene.

Day mode: It can be used in the scene with sufficient ambient light for 24 hours, do not turn on the fill light, and the image is in color.

Night mode: it can be used in the scene where there is insufficient ambient light for 24 hours, turn on the fill light (it can be selected according to the four modes of the fill light).

Auto mode: Automatically switch the set fill light mode according to the brightness of the environment.

Timing mode: Set the start and end time of the day, this time period is in day mode.

The brightness of the fill light can be selected between automatic and manual, automatic mode is meaning it can be adjusted automatically according to the current environment; manual mode, you can scroll to check or set the value to control.

## 2.2.7 Noise Reduction

Figure 2-19 shows the Noise Reduction interface.

Figure 2-19 Noise Reduction interface (manual)

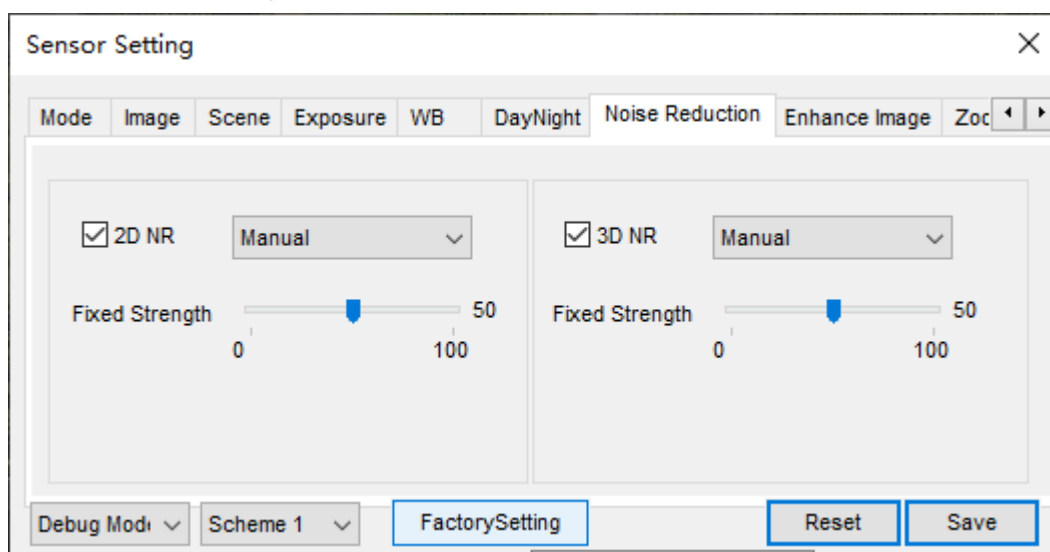

## Sensor Setting

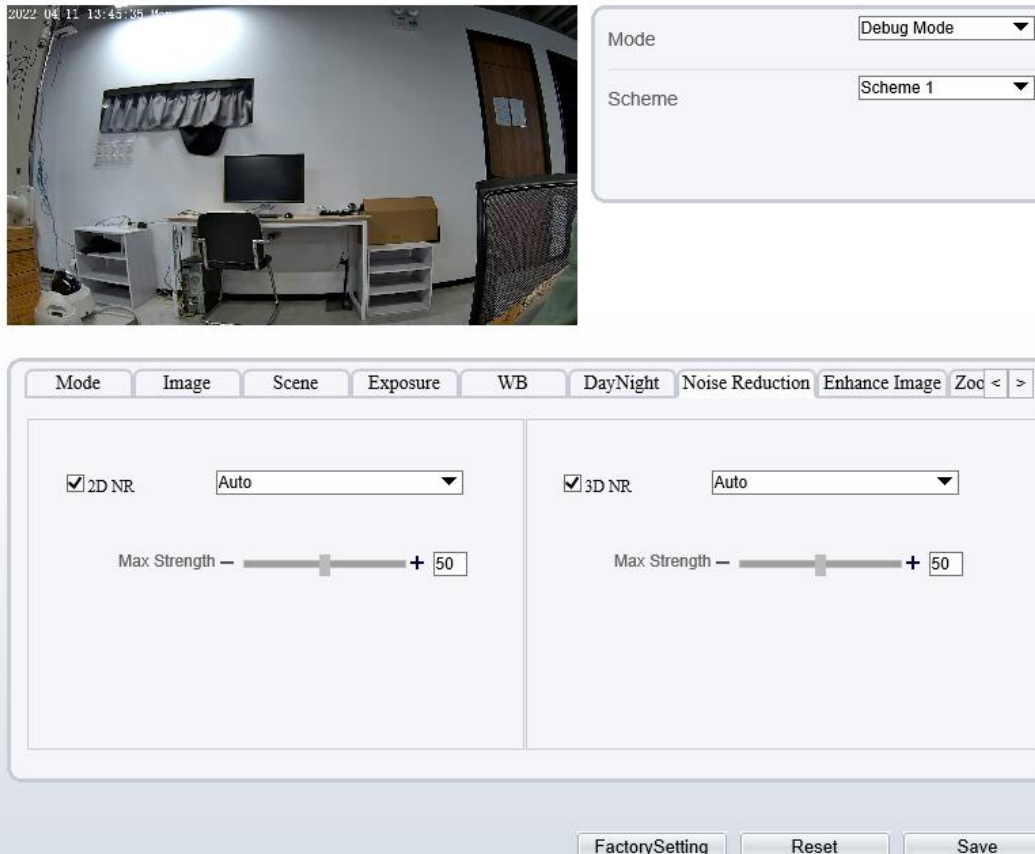

Figure 2-20 Noise Reduction interface(auto)

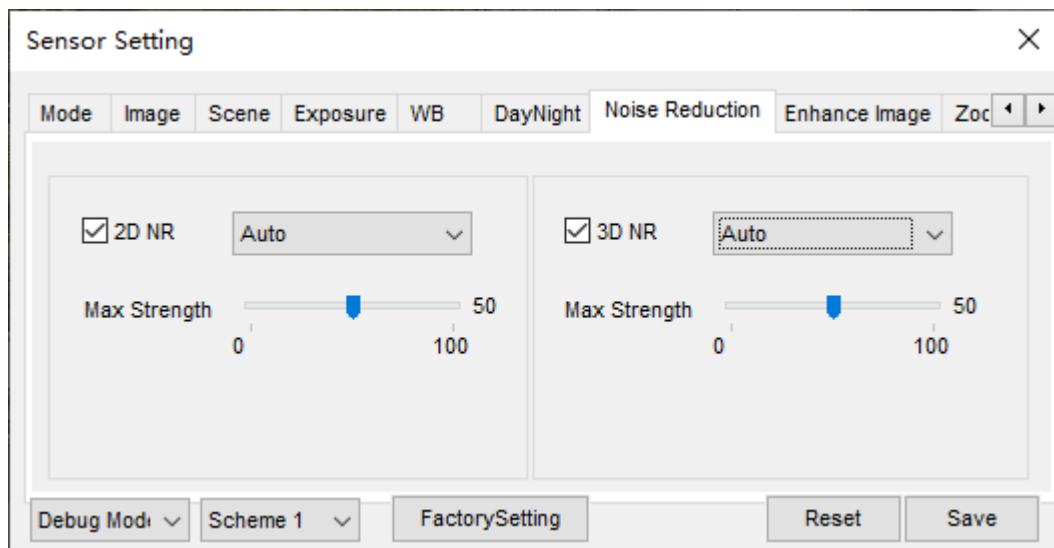

Table 2-7 describes DNR parameters.

**Table 2-7** DNR parameters description

Parameter	Meaning	Configuration Method
2D NR	Reduce noise of image.	[Configuration method] Select from the drop-down list [Default value] Auto
3D NR	Reduce noise of image.	[Configuration method] Select from the drop-down list [Default value] Auto
Max Strength	It is valid in auto noise filter mode. When the parameter value is 0, the noise filter is disabled. When the parameter value is greater than 0, the noise filter is enabled, and the system automatically adjusts the noise filter level based on the ambient brightness without exceeding the value of this parameter.	[Setting method] Drag the slider. [Default value] <b>50</b>
Fixed Strength	It is valid in a manual noise filter mode.	[Setting method] Drag the slider. [Default value] <b>50</b>

## 2.2.8 Enhance Image

Figure 2-21 shows the enhance image interface and Table 2-8 shows the enhance image parameter.

Figure 2-21 Enhance image interface

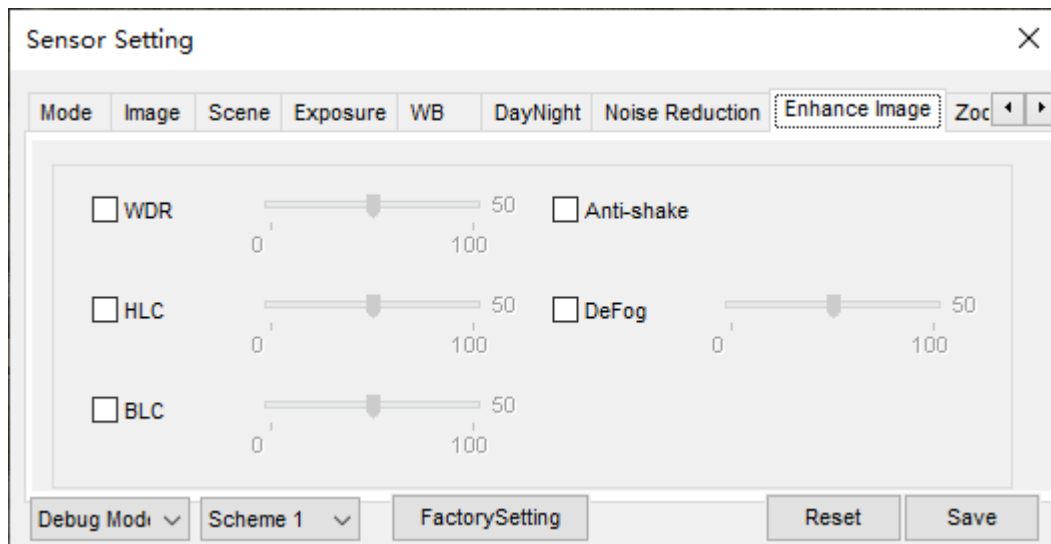

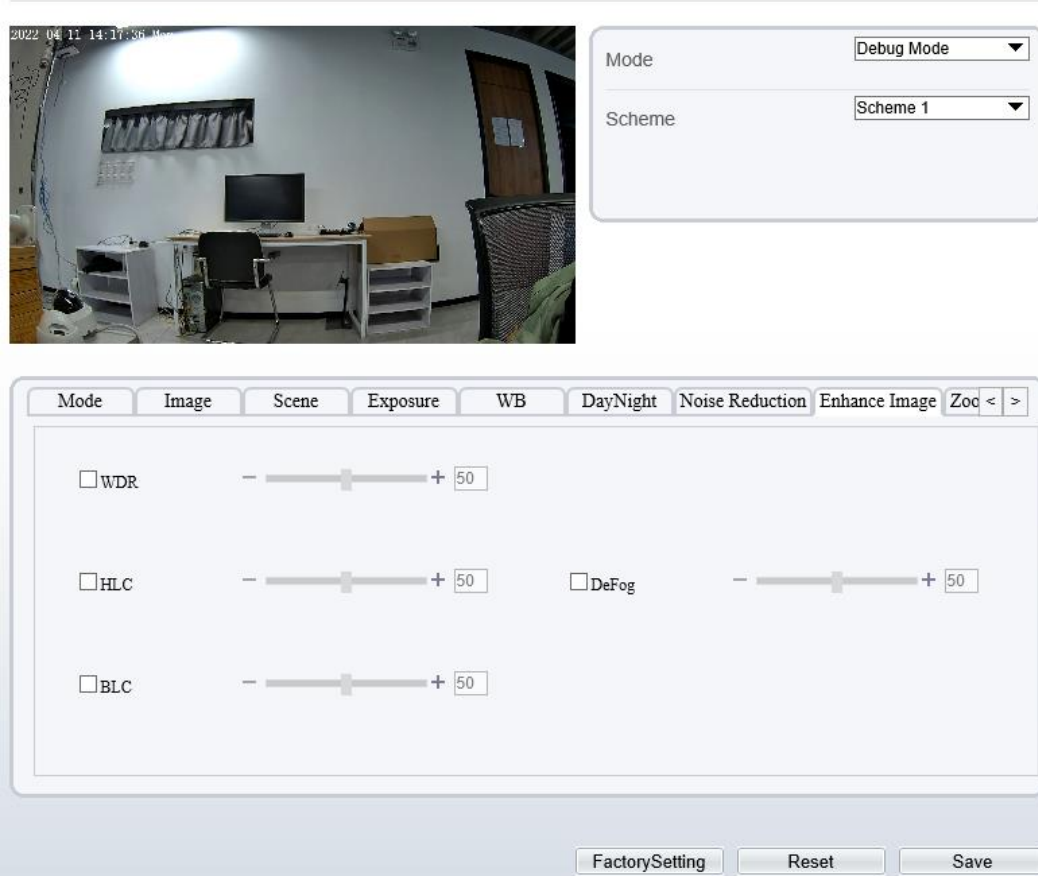

**Table 2-8** Enhance image parameters description

Parameter	Meaning	Configuration Method
WDR	It is used to display the foreground and background at the same time in the environment with a large brightness difference. When the brightness difference is larger, you can increase the WDR level to obtain better image effect.	[Setting method] Tick the WDR mode and drag the slider. [Default value] <b>50</b>
HLC	It provides a clearer view of an image in the highlight environment. When HLC is enabled, the total brightness of an image is reduced, allowing you to view objects in front of the highlight.	[Setting method] Tick the HLC mode and drag the slider. [Default value] <b>50</b>
BLC	It provides a clearer view of an image in the backlight environment. When BLC is enabled, the total brightness of an image increases, allowing you to view objects in front of the backlight. Meanwhile, the objects behind the backlight are exposed excessively.	[Setting method] Tick the HLC mode and drag the slider. [Default value] <b>50</b>

Parameter	Meaning	Configuration Method
Anti-shake	The shakes and visual angle of image will reduce when the camera shakes slightly and the anti-shake is enable.	[Setting method] Tick the Anti-shake mode.
DeFog	It provides a clearer view of an image in the fogged environment when Defog is enabled. As the value increases, the image becomes clearer.	[Setting method] Tick the Defog mode and drag the slider. [Default value] <b>50</b>

## 2.2.9 Zoom Focus (Supplied for some model)

Figure 2-22 and Figure 2-23 shows the zoom focus interface and Table 2-8 shows the zoom focus parameter.

Figure 2-22 Zoom focus interface for IP camera

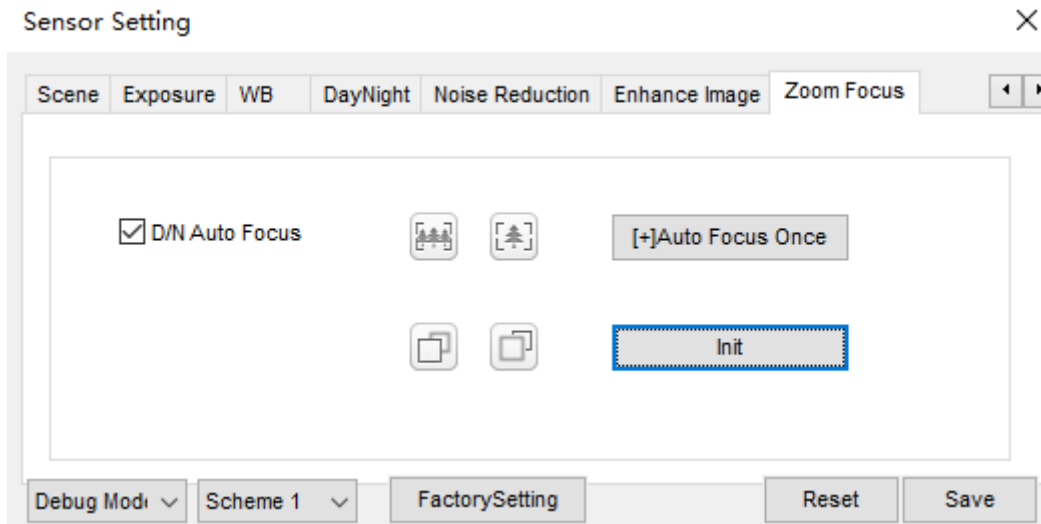

 Sensor Setting

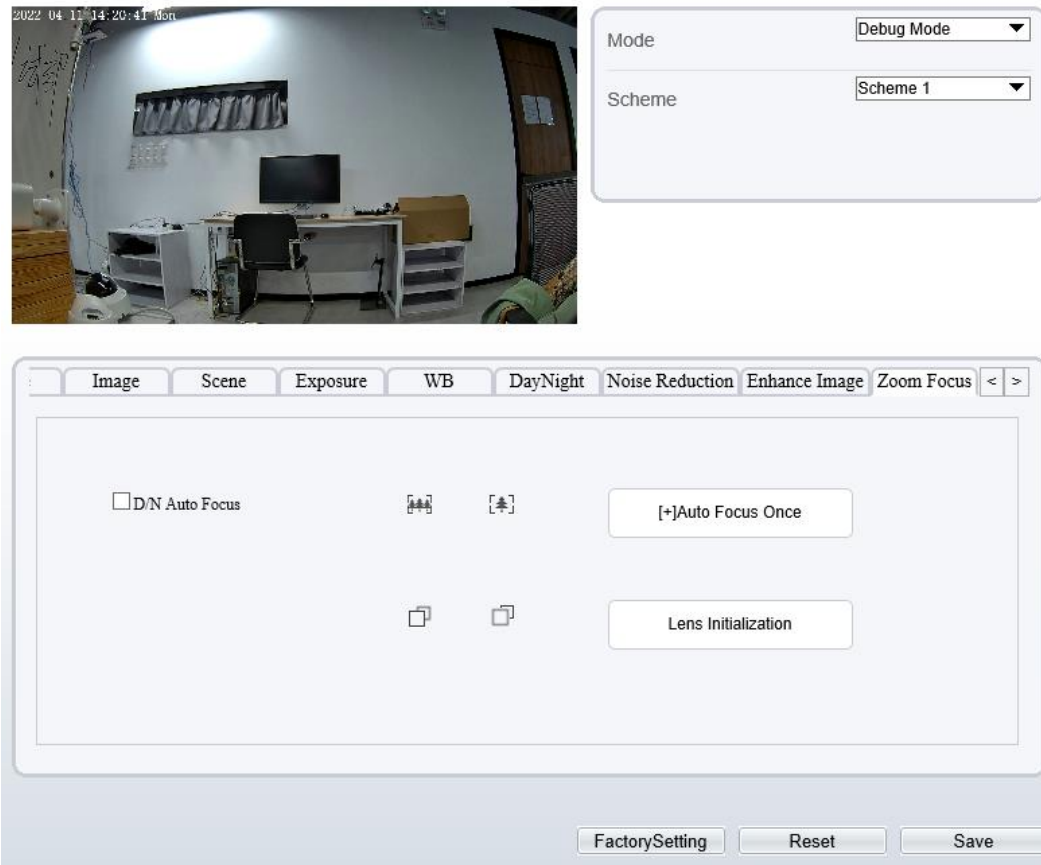

Figure 2-23 Zoom focus interface for high speed dome

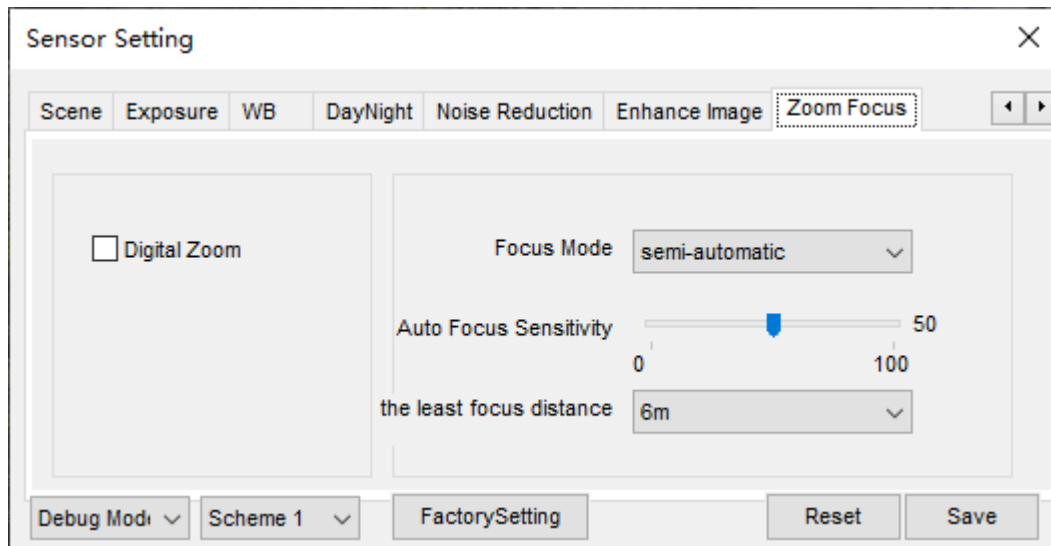



Table 2-9 Zoom focus parameters description

Parameter	Meaning	Configuration Method
D/N Auto Focus	It is used to trigger auto focus when day to night or night to day.	[Setting method] Tick the Auto focus.

Parameter	Meaning	Configuration Method
Auto Focus Once	Click to trigger once auto focus.	[Setting method] Click the button.
Init	The lens of camera returns to the initial position.	[Setting method] Click the button.
Digital	This function enables digital zoom after an image is zoomed in by 37 times in optical mode.	[Setting method] Tick the Digital.
Focus Mode	<p>It can be set to the auto, manual or semi-automatic mode.</p> <p>Auto focus mode: The system automatically triggers focus based on application scenarios.</p> <p>Manual focus mode: You can trigger focus by using the buttons on the client.</p> <p>Semi-automatic focus mode: The system only automatically trigger focus once when the PTZ move or zoom in a scene.</p>	<p>[Configuration method] Select from the drop-down list</p> <p>[Default value] <b>Semi-automatic</b></p>
Auto Focus Sensitivity	It indicates the sensitivity of auto focus. When the sensitivity is high, the camera movement is more likely to focus again at slight changes of an image.	<p>[Setting method] Drag the slider.</p> <p>[Default value] <b>50</b></p>
The least focus distance	<p>It indicates the minimum focus distance. A camera does not focus when the distance is smaller than this value. For example, if the minimum focus distance is set to 1.5 m, a camera focuses only on objects more than 1.5 m away, and the changes of objects less than 1.5 m away do not affect the focusing.</p> <p> <b>NOTE</b> This parameter applies only to visible light.</p>	<p>[Configuration method] Select from the drop-down list</p> <p>[Default value] 3 m</p>

# 3 Configure the Device

---

## 3.1 Device Information

### Description

The device information includes:

- Device ID, name, type, model, manufacturer name and MAC address.
- Hardware and software versions.
- Number of video channels, number of alarm input channels, number of alarm output channels, and number of serial ports, network cards.

 **NOTE**

- You can modify the device name. All other parameters can only be viewed.
- When the device is upgraded, the device information is updated automatically.

### Procedure

Step 1 Click Configuration > Device Info.

The **Device Info** page is displayed, as shown in Figure 3-1.

Figure 3-1 Device Info page

 **Device Info**

---

Device ID	547577
Device Name	<input type="text"/> ✓
MAC Address	00:1C:27:54:75:77

Camera Type	AI_MULTIOBJECT
Product Model	SN-IPV8080EFAR-B2.8-23
Manufacturer Name	IPCamera

Hardware Version	V220014_5
Firmware Version	v3.6.1603.1004.3.0.11.1.0.D01
Uboot Version	v1.2
Kernel Version	v2.1_PDTJul

Channel Quantity	1
Alarm Input Quantity	1
Alarm Output Quantity	1
Serial Port Quantity	0
Network Card Quantity	1

[Refresh](#)

Step 2 View the device information, set the device name according to Table 3-1.

**Table 3-1** Device parameters

Parameter	Description	Setting
Device ID	Unique device identifier used by the platform to distinguish the devices.	[Setting method] The parameter cannot be modified.
Device Name	Name of the device. NOTE The device name cannot exceed 32 bytes or 10 simplified characters; otherwise, the modification fails.	[Setting method] Enter a value manually.
MAC Address	N/A	[Setting method]
Camera Type		These parameters cannot be modified.
Product Model		

Parameter	Description	Setting
Manufacturer Name		
Hardware Version		
Firmware Version		
Uboot version		
Kernel version		
Video Channel(s)		
Channel Quantity		
Alarm Input Quantity		
Alarm Output Quantity		
Serial Port Quantity		
Network card Quantity		

Step 3 Click .

- If the message "Apply success!" is displayed, click **OK**. The system saves the settings.
- If the message "Apply failed!" is displayed, you must apply for the Parameter Configure permission from an administrator. For details, see 11.1 Configure a User.

## 3.2 Video and Audio Stream

### Procedure

Step 1 Click Configuration > Stream > Base Stream.

The **Stream Configuration** page is displayed, as shown in Figure 3-2.

Figure 3-2 Stream Configuration page

 **Stream**

---

Stream ID	1
Name	stream1

Video Encode Type	H265
Video Encode Level	Mid
Audio Encode Type	G711_ALAW
Resolution	3840x2160
Frame Rate(fps)	30
I Frame Interval(Unit: Frame)	60
Bit Rate Type	CBR
Bit Rate(kbps)(500-16000)	6000
Smart Encode	<input type="checkbox"/> OFF

 **Stream**

---

Stream ID	1
Name	stream1

Video Encode Type	H265
Video Encode Level	Mid
Audio Encode Type	G711_ALAW
Resolution	1920x1080
Frame Rate(fps)	30
I Frame Interval(Unit: Frame)	60
Bit Rate Type	VBR
Max Bitrate(kbps)(500-12000)	4096
Image Quality	Mid
Smart Encode	<input checked="" type="checkbox"/> ON

Step 2 Set the parameters according to Table 3-2.

**Table 3-2** Stream configuration parameters

Parameter	Description	Setting
Stream ID	<p>The device supports at most three main streams.</p> <ul style="list-style-type: none"> <li>Streams 1 and 2 adopt H.264 code.</li> <li>The maximum resolution can be set for streams 1.</li> <li>Only a low resolution can be set for stream 2.</li> <li>Stream 3 is the lowest resolution.</li> <li>Stream 4 is the sub stream.</li> </ul>	<p>[Setting method]</p> <p>Select a value from the drop-down list box.</p>
Name	<p>Stream name.</p> <p>NOTE</p> <p>The stream name consists of Chinese character, number, character and underline.</p>	<p>[Setting method]</p> <p>Enter a value manually. The value cannot exceed 32 bytes.</p> <p>[Default value]</p> <p>Stream 1</p>
Video Encode Type	<p>The video codec determines the image quality and network bandwidth required by a video. Currently, the following codec standards are supported:</p> <ul style="list-style-type: none"> <li>MJPEG</li> </ul> <p>MJPEG is a standard intra-frame compression codec. The compressed image quality is good. No mosaic is displayed on motion images. MJPEG does not support proportional compression and requires large storage space. Recording and network transmission occupy large hard disk space and bandwidth. MJPEG is not applicable to continuous recording for a long period of time or network transmission of videos. It can be used to send alarm images.</p> <ul style="list-style-type: none"> <li>H.264</li> </ul> <p>H.264 consists of H.264 Base Profile, H.264 Main Profile and H.264 High profile. The performance of H.264 High Profile is higher than that of H.264 Main Profile, and the performance of H.264 Main Profile is higher than that of H.264 Base Profile. If a hardware decoding device is used, select the appropriate codec based on the decoding performance of the device.</p> <p>H.264 High Profile has the highest requirements on the hardware performance, and H.264 Base Profile has the lowest requirements on the hardware performance.</p> <ul style="list-style-type: none"> <li>H.265</li> </ul> <p>H.265 is the advanced video encoding standard. It's the improvement standard from H.264. H.265 improves the streams, encoding quality and algorithm complexity to make configuration as optimization.</p>	<p>[Setting method]</p> <p>Select a value from the drop-down list box.</p> <p>[Default value]</p> <p>H.264 High Profile</p> <p>NOTE</p> <p>The H.264 High Profile codec means high requirements on the hardware. If the hard-decoding capability is low, use H.264 Main Profile or H.264 Base Profile.</p>

Parameter	Description	Setting
Audio Encode Type	<p>The following audio codec standards are supported:</p> <ul style="list-style-type: none"> <li>• G711_ULAW: mainly used in North America and Japan.</li> <li>• G711_ALAW: mainly used in Europe and other areas.</li> <li>• RAW_PCM: codec of the original audio data. This codec is often used for platform data.</li> </ul>	<p>[Setting method]</p> <p>Select a value from the drop-down list box.</p>
Resolution	<p>A higher resolution means better image quality.</p> <p>NOTE</p> <p>IP cameras support the different resolutions based on the model.</p>	<p>[Setting method]</p> <p>Select a value from the drop-down list box.</p>
Frame Rate (fps)	<p>Frame rate is the number of images, shots, or frames that a camera can take per second. The frames per second determine the smoothness of a video. A video whose frame rate is higher than 22.5 f/s is considered as smooth by human eyes.</p> <p>Frame rates for different frequencies are as follows:</p> <ul style="list-style-type: none"> <li>• 50 Hz: 1–25 f/s</li> <li>• 60 Hz: 1–30 f/s</li> </ul> <p>NOTE</p> <p>The frequency is set on the <b>Device Configuration &gt; Camera</b> page. The biggest MJPEG coding format frame rate is 12 frames per second.</p>	<p>[Setting method]</p> <p>Select a value from the drop-down list</p>
I Frame Interval (f)	<p>I frame do not require other frames to decode.</p> <p>A smaller I frame interval means better video quality but higher bandwidth.</p>	<p>[Setting method]</p> <p>Select a value from the drop-down list</p>
Bit Rate Type	<p>The bit rate is the number of bits transmitted per unit of time.</p> <p>The following bit rate types are supported:</p> <ul style="list-style-type: none"> <li>• Constant bit rate (CBR)</li> </ul> <p>The compression speed is fast; however, improper bit rate may cause vague motion images.</p> <ul style="list-style-type: none"> <li>• Variable bit rate (VBR)</li> </ul> <p>The bit rate changes according to the image complexity. The encoding efficiency is high and the definition of motion images can be ensured.</p>	<p>[Setting method]</p> <p>Select a value from the drop-down list box.</p>
Max Bitrate (500-12000)	<p>Indicates the maximal value of the bit rate.</p>	<p>[Setting method]</p> <p>Enter a value manually.</p>
Image Quality	<p>The video quality the camera output.</p>	<p>[Setting method]</p> <p>Select a value from the drop-down list box.</p>

Parameter	Description	Setting
Smart Encode	Smart Encode. <ul style="list-style-type: none"> <li>• Smart encode includes H.264 &amp; H.265.</li> <li>• The storage space will be reduced fifty percent when smart encode is enabled.</li> <li>• Only main stream supports smart encode.</li> </ul>	[Setting method] Click the button on to enable <b>Smart Encode</b> .

Step 3 Click **Apply**.

- If the message "Apply success!" is displayed, and the system saves the settings.
- If the message "Apply failed!" is displayed, you must apply for the Parameter Configure permission from an administrator. For details, see 11.1 Configure a User.
- If a message indicating that the bit rate invalid is displayed, enter a new bit rate value.

### 3.3 ROI Parameter

#### Procedure

Step 1 Click Configuration > Stream > ROI.

The ROI page is displayed, as shown in Figure 3-3.

Figure 3-3 ROI Configuration page

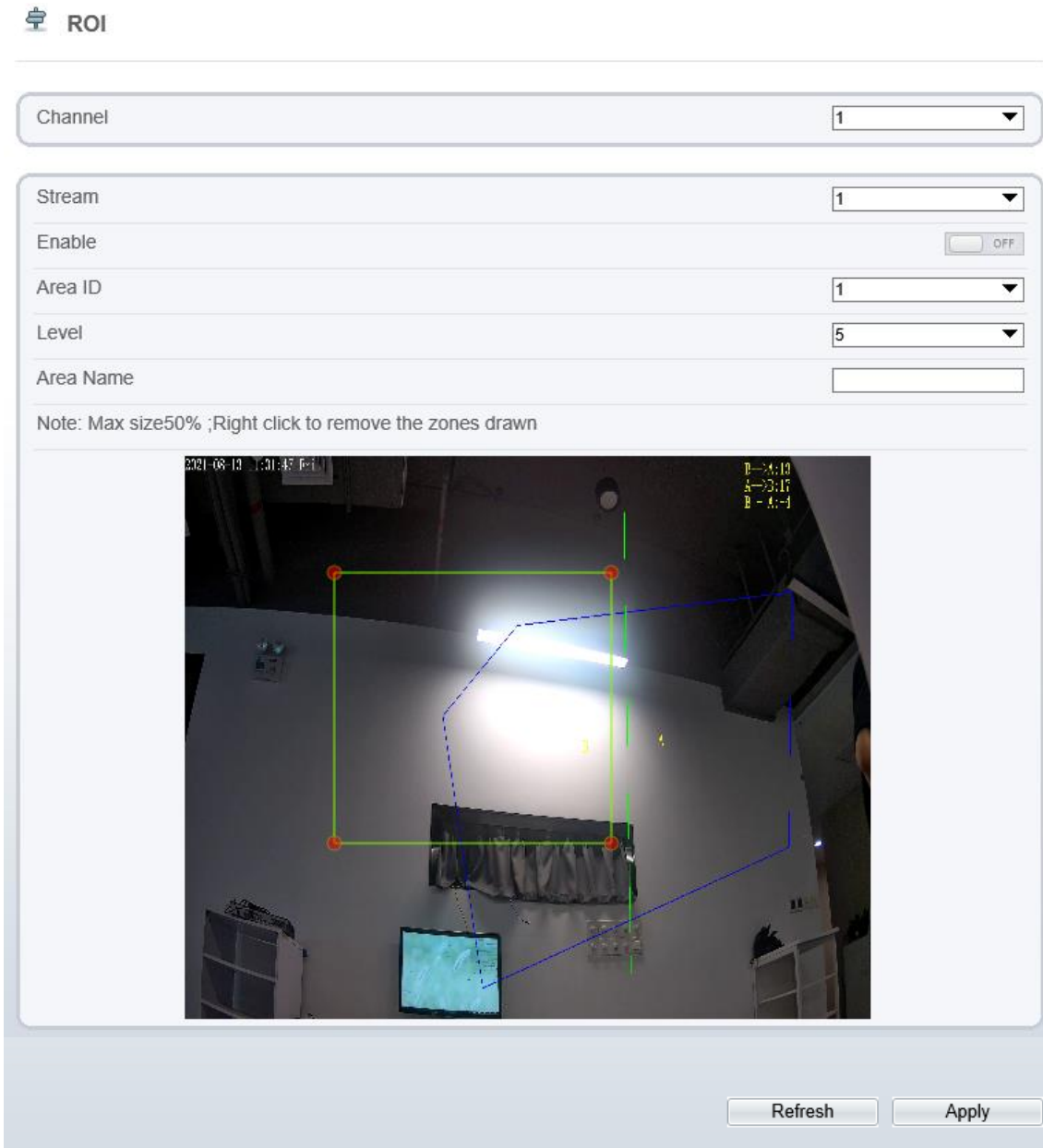

Step 2 Set the parameters according to Table 3-3.

**Table 3-3** ROI configuration parameters

Parameter	Description	Setting
Stream	Stream ID.	[Setting method] Select a value from the drop-down list box. [Default value] Stream 1
Enable	Enable the ROI	[Setting method] Click the button. [Default value] OFF
Area ID	ROI area ID	[Setting method] Select a value from the drop-down list box. [Default value] 1
Level	The visual effect of ROI. The higher the level is, the clearer the area is; the more blurred outside the area.	[Setting method] Select a value from the drop-down list box. [Default value] 5
Area Name	The marked name used for areas.	[Setting method] Enter a value manually. The value cannot exceed 32 bytes.

Step 3 Click **Apply**.

The message "Apply success!" is displayed, and the system saves the settings.

## 3.4 Snapshot

### Procedure

Step 1 Click Configuration > Stream > Snapshot.

The **ROI** page is displayed, as shown in Figure 3-3.

Figure 3-4 ROI Configuration page

The screenshot shows a configuration interface for ROI. At the top left, there is a camera icon and the word "Snapshot". Below this, there are two rows of configuration options. The first row is "Snapshot Resolution" with a dropdown menu showing "1280x720". The second row is "Snapshot Quality" with a dropdown menu showing "Mid". At the bottom right, there are two buttons: "Refresh" and "Apply".

Step 2 Set the parameters according to Table 3-3.

Table 3-4 ROI configuration parameters

Parameter	Description	Setting
Snapshot Resolution	Choose resolution of snapshot	[Setting method] Select a value from the drop-down list box. [Default value] 1280*720
Snapshot Quality	Choose the quality of snapshot.	[Setting method] Click the button. [Default value] Mid

## 3.5 Local Network

### Description

Local network parameters include:

- IP protocol
- IP address
- Subnet mask
- Default gateway
- Dynamic Host Configuration Protocol (DHCP)
- Preferred Domain Name System (DNS) server
- Alternate DNS server
- MTU

### Procedure

Step 1 Choose Configuration > Device > Local Network.

The **Local Network** page is displayed, as shown in Figure 3-5.

Figure 3-5 Local Network page

The screenshot shows the 'Local Network' configuration page. It contains several sections:

- Network Card ID:** A dropdown menu set to '1'.
- IP Protocol:** A dropdown menu set to 'IPv4'.
- DHCP:** A toggle switch set to 'ON'.
- DHCP IP:** A text field containing '192.168.0.120'.
- Preferred DNS Server:** A text field containing '192.168.0.1'.
- Alternate DNS Server:** A text field containing '192.168.0.2'.
- MTU(1280-1500):** A text field containing '1500'.

At the bottom right, there are two buttons: 'Refresh' and 'Apply'.

Step 2 Set the parameters according to Table 3-5.

**Table 3-5** Local network parameters

Parameter	Description	Setting
IP Protocol	IPv4 is the IP protocol that uses an address length of 32 bits.	[Setting method] Select a value from the drop-down list box. [Default value] IPv4
Obtain IP address automatically	The device automatically obtains the IP address from the DHCP server.	[Setting method] Click the button on to enable <b>obtain IP address automatically</b> . NOTE To query the current IP address of the device, you must query it on the platform based on the device name.
DHCP IP	IP address that the DHCP server assigned to the device.	N/A
IP Address	Device IP address that can be set as required.	[Setting method] Enter a value manually. [Default value] 192.168.0.120

Parameter	Description	Setting
Subnet Mask	Subnet mask of the network adapter.	[Setting method] Enter a value manually. [Default value] 255.255.255.0
Default Gateway	This parameter must be set if the client accesses the device through a gateway.	[Setting method] Enter a value manually. [Default value] 192.168.0.1
Preferred DNS Server	IP address of a DNS server.	[Setting method] Enter a value manually. [Default value] 192.168.0.1
Alternate DNS Server	IP address of a domain server. If the preferred DNS server is faulty, the device uses the alternate DNS server to resolve domain names.	[Setting method] Enter a value manually. [Default value] 192.168.0.2
MTU	Set the maximum value of network transmission data packets.	[Setting method] Enter a value manually. NOTE The MTU value is range from 1280 to 1500, the default value is 1500, Please do not change it arbitrarily.

Step 3 Click **Apply**.

- If the message "Apply success!" is displayed, and the system saves the settings. The message "Set network parameter success, Please login system again" is displayed. Use the new IP address to login to the web management system.
- If the message "Invalid IP Address", "Invalid Subnet Mask", "Invalid default gateway", "Invalid primary DNS", or "Invalid space DNS" is displayed, set the parameters correctly.

## 3.6 Device Port

### Description

You must configure the HTTP port, control port, Real Time Streaming Protocol (RTSP) port and SSL Control port for device route mapping in a LAN.

### Procedure

Step 1 Choose Configuration > Device > Device Port.

The **Device Port** page is displayed, as shown in Figure 3-6.

Figure 3-6 Device Port page

 **Device Port**

---

Control Port	<input type="text" value="30001"/>
Http Port	<input type="text" value="80"/>
RTSP Port	<input type="text" value="554"/>
HTTPS Port	<input type="text" value="443"/>
SSL Control Port	<input type="text" value="20001"/>

---

 **Device Port**

---

Control Port	<input type="text" value="30001"/>
Http Port	<input type="text" value="80"/>
RTSP Port	<input type="text" value="554"/>
HTTPS Port	<input type="text" value="443"/>

Step 2 Set the parameters according to Table 3-6.

**Table 3-6** Device port parameters

Parameter	Description	Setting
Control Port	Port used for audio and video transfer and signaling interaction.	[Setting method] Enter a value manually. [Default value] 30001
HTTP Port	Port used in web access.	[Setting method] Enter a value manually. [Default value] 80
RTSP Port	RTSP protocol port.	[Setting method] Enter a value manually. [Default value] 554

Parameter	Description	Setting
HTTPS Port	Hyper Text Transfer Protocol over Secure Socket Layer	[Setting method] Enter a value manually. [Default value] 443
SSL Control Port	Secure socket layer control port. Only for Some Models.	[Setting method] Enter a value manually. [Default value] 20001

 **NOTE**

It's not recommended to modify the control port, for details about the value ranges of the control port, HTTP port and SSL Control port, see the communication matrix.

Step 3 Click **Apply**.

- If the message "Apply success!" is displayed, and the system saves the settings.
- If the message "Invalid Control Port, please input an integer between 1025 and 65535" is displayed, enter correct port numbers.

## 3.7 Date and Time

### Description

On the **Date and Time** page, you can modify the date and time. Parameters that can be set include:

- Time zone and daylight-saving time (DST)
- Date and time
- Network Time Protocol (NTP) server

### Procedure

Step 1 Choose Configuration > Device > Date and Time.

The **Date and Time** page is displayed, as shown in Figure 3-7. Table 3-7 describes the parameters.

Figure 3-7 Date and Time page

 **Date and Time**

---

Time Zone [(GMT) Greenwich Mean Time : Dublin, Edinburgh, Lisbon, London ▼]

Daylight Savings Time  ON

Begin Time Mar ▼ 5th ▼ Sun ▼ 1:00 ▼

End Time Oct ▼ 5th ▼ Sun ▼ 2:00 ▼



Device Time 02/27/2019 15:14:08

Current PC Time 02/27/2019 15:11:08 

Set Manually 02/27/2019 15:13:24 

NTP  ON

NTP Server Addr

NTP Port 123

Check the time interval(greater than 10s) 3600



**Table 3-7** Date and Time parameters

Parameter	Description	Setting
Time Zone	N/A	[Setting method] Select a value from the drop-down list box. [Default value] Greenwich mean time
Daylight Saving Time	When the DST start time arrives, the device time automatically goes forward one hour. When the DST end time arrives, the device time automatically goes backward one hour.  NOTE DST is the practice of advancing clocks so that evenings have more daylight and mornings have less. Currently, about 110 countries in the world use DST. Different countries have different DST provisions. Since March 27, 2011, Russia has started to use permanent DST.	[Setting method] Click the button on to enable <b>Daylight Saving Time</b> .

Parameter	Description	Setting
Device Time	Device display time.	[Setting method] <ul style="list-style-type: none"> <li>• Synchronize the time from the PC.</li> <li>• Enter a value manually.</li> </ul>
Current PC Time	Time on the current PC.	N/A
Set Manually	Enables you to manually set the device time.	[Setting method] Click <b>Set Manually</b> and set the date and time in the format <i>YYYY-MM-DD HH:MM:SS</i> .
NTP	IP address or domain name of the NTP server.	[Setting method] Click the button on to enable <b>NTP</b> and enter a value manually.
NTP Server Addr	The NTP server IP.	[Setting method] Enter a value manually.
NTP Port	Port number of the NTP server.	[Setting method] Enter a value manually. [Default value] 123
Check the time interval (at least 10 s)	Set time interval to check if the device time synchronizes with the NTP server time.	[Setting method] Enter a value manually. [Default value] 3600

Step 2 Select a time zone from the **Time Zone** drop-down list box.

Step 3 (Optional) Click the button on to enable **Daylight Saving Time** and specify the DST start time and end time.

Step 4 Modify the device time.

- Synchronizing time from the PC  
Click **Current PC Time**.
- Manually setting the device time
  - Click Set Manually.
  - A time setting control is displayed.
  - Set the date and time.

Step 5 Configure the NTP.

1. Click the button on to enable **NTP**.
2. Enter the IP address or domain name of the NTP server, the port number and the time interval.

Step 6 Click .

The message "Apply success!" is displayed and the system saves the settings.

## 3.8 Camera

### Procedure

Step 1 Choose Configuration > Device > Camera.

The **Camera** page is displayed, as shown in Figure 3-8. Table 3-8 describes the parameters.

Figure 3-8 Camera page

Table 3-8 Camera parameters

Parameter	Description	Setting
Video System	<p>The options are as follows:</p> <ul style="list-style-type: none"> <li>• PAL: Used in Europe and China mainland, India, Pakistan, etc.</li> <li>• NTSC: Used in USA, Japan, South Korea, and Taiwan Province of China, etc.</li> </ul>	<p>[Setting method] Select a value from the drop-down list box.</p> <p>[Default value] PAL</p> <p>NOTE Whether the video system can be changed depends on the device model.</p>
Video Refresh Frequency	<p>The options are as follows:</p> <ul style="list-style-type: none"> <li>• 50 Hz: corresponds to the PAL system.</li> <li>• 60 Hz: corresponds to NTSC system.</li> </ul>	<p>[Setting method] Follow the video standard.</p>

Step 2 Enter a channel name.

 **NOTE**

The channel name must be within the length of 0 to 32 bytes, it is combined with digital and character (except for some special character, such as < > % & \",=+).

Step 3 Click .

The message "Apply success!" is displayed.

 **NOTE**

If the video system is modified, the message "The device will be restart, are you sure to modify?" is displayed, and the system automatically saves the settings. The settings take effect after the device restarts.

## 3.9 OSD

### Description

The on-screen display (OSD) function allows you to display the device name, channel ID and name, time, and other customized contents on videos. You can drag the OSD frames to anywhere you want to put.

- When the resolution is D1 and CIF, the OSD customized in web interface can show at most 22 words normally.
- The OSD support simplified Chinese, English, digital and some special character only.

### Procedure

Step 1 Choose Configuration > Device > OSD.

The **OSD** page is displayed, as shown in Figure 3-9.

Figure 3-9 PTZ OSD page

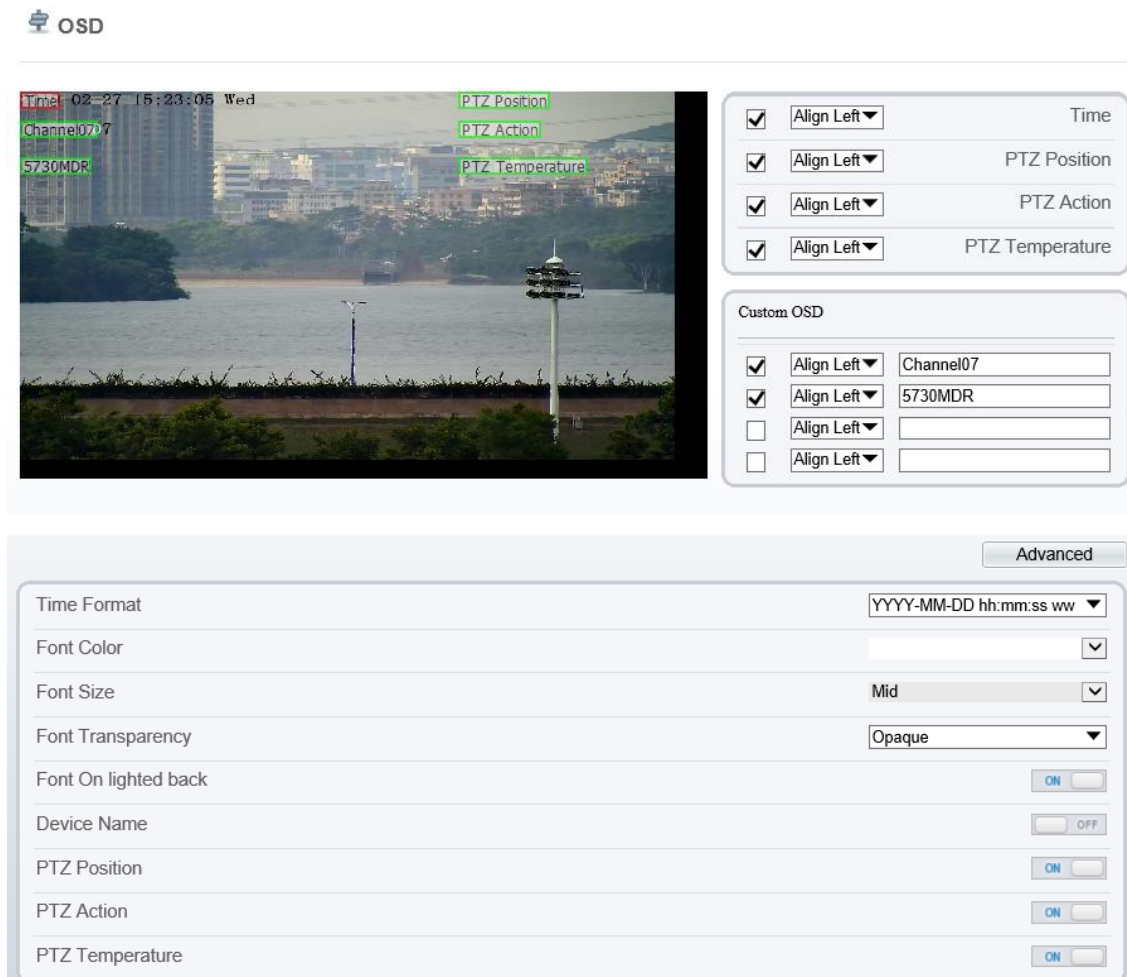

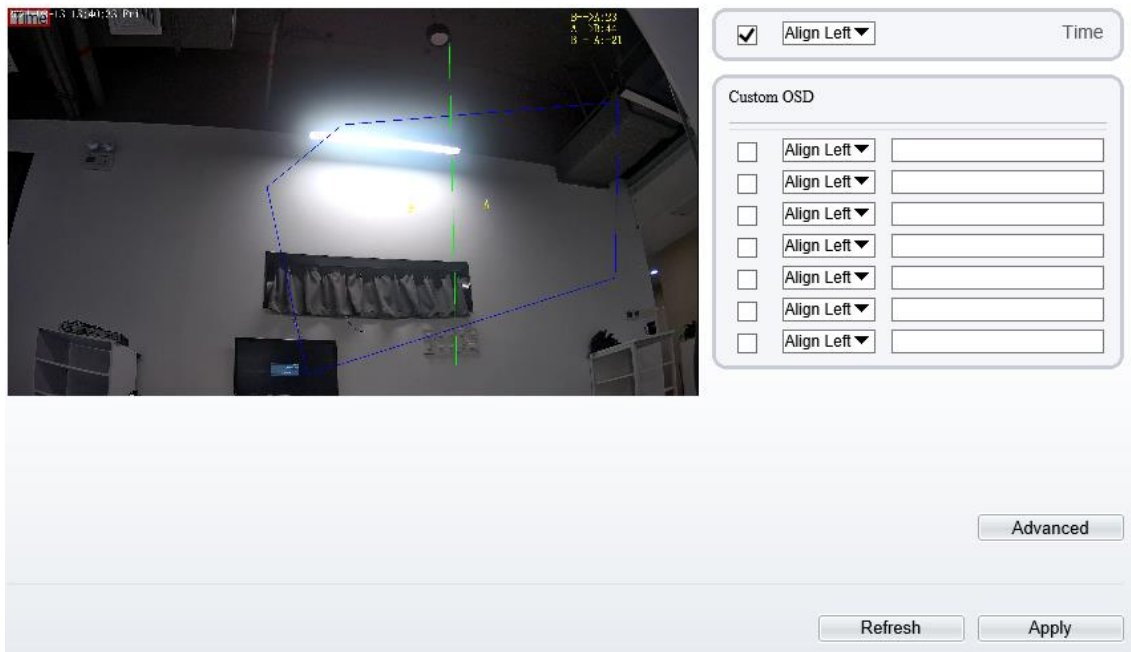

Step 2 Set the parameters according to Table 3-9.

**NOTE**

- There are at most six OSD display areas..

**Table 3-9** OSD parameters

Parameter	Description	Setting
Time	Indicates whether to display the time.	[Setting method] Tick the time.
Focusing on the state	Displays the state of focusing on. NOTE: Only Supplied for camera of auto focusing lens.	[Setting method] Tick the Focusing on the state.
Custom OSD	Enables you to enter a line of characters.	[Setting method] 1. Tick the custom OSD list. 2. Enter the characters. Click  to save the value.
Time Format	Format in which the time is displayed.	[Setting method] Select a value from the drop-down list box. [Default value] YYYY-MM-DD hh:mm:ss ww

Parameter	Description	Setting
Font Color	Set the font color.	[Setting method] Select a value from the drop-down list box. [Default value] Blank
Font Size	Set the font size.	[Setting method] Select a value from the drop-down list box. [Default value] Mid
Font Transparency	Set the font transparency.	[Setting method] Select a value from the drop-down list box. [Default value] Opaque
Font on lighted back	Enable the font on lighted back.	[Setting method] Click the button on to enable <b>Font on lighted back</b> .
Device Name	Indicates whether to display the device name.	[Setting method] Click the button on to enable <b>Device Name</b>

Step 3 Click **Advanced**, set the parameter of “ Time Format”, “Font Color”, “Font Transparency”, “Font on lighted back”

Step 4 Click **Apply**.

The message "Apply success!" is displayed And the system saves the settings.

## 3.10 Microphone (Only for Some Models)

### Description

On the **Microphone** page, you can set the microphone input mode and volume.

### Procedure

Step 1 Choose Configuration > Device > Microphone.

The **Microphone** page is displayed, as shown in Figure 3-10. Table 3-10 describes the parameters.

Figure 3-10 Microphone page



Table 3-10 Microphone parameters

Parameter	Description	Setting
Enable Microphone	Indicates whether to enable the microphone function.	[Setting method] Click the button on to enable microphone.
Microphone Type	Microphone types include: • Line In An active audio input is required.	[Setting method] Select a value from the drop-down list box.
Microphone Volume	Allows you to adjust the microphone volume.	[Setting method] Slide the slider left or right. [Default value] 50 NOTE The value ranges from 0 to 100.

Step 2 Click **Apply**.

The message "Apply success!" is displayed. And the system saves the settings.

## 3.11 Audio Output (Only for Some Models)

### Description

On the **Microphone** page, you can set the microphone input mode and volume.

### Procedure

Step 1 Choose Configuration > Device > Audio Output.

The **Audio Output** page is displayed, as shown in Figure 3-11. Table 3-11 describes the parameters.

Figure 3-11 Audio output page

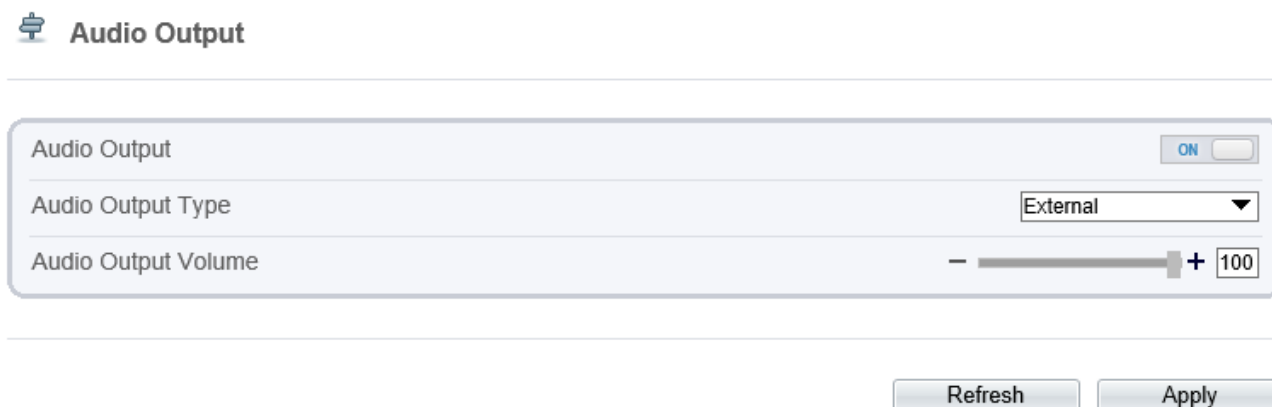

**Table 3-11** Audio output parameters

Parameter	Description	Setting
Enable audio output	Indicates whether to enable the audio output function.	[Setting method] Click the button on to enable audio output.
Microphone Type	Microphone types include: • External An active audio output is required.	[Setting method] Select a value from the drop-down list box.
Audio output Volume	Allows you to adjust the audio output volume.	[Setting method] Slide the slider left or right. [Default value] 50 NOTE The value ranges from 0 to 100.

Step 2 Click **Apply**.

The message "Apply success!" is displayed. And the system saves the settings.

## 3.12 CVBS Function (Supplied for some models)

### Preparation

Connect a display device to the VIDEO OUT port.

### Description

When the analog output function is enabled, the IP camera can send analog signals to a video server or display device through the VIDEO OUT port.

### Procedure

Step 1 Choose Configuration > Device > CVBS.

The **BNC Video Output** page is displayed, as shown in Figure 3-12.

Figure 3-12 BNC Video Output page

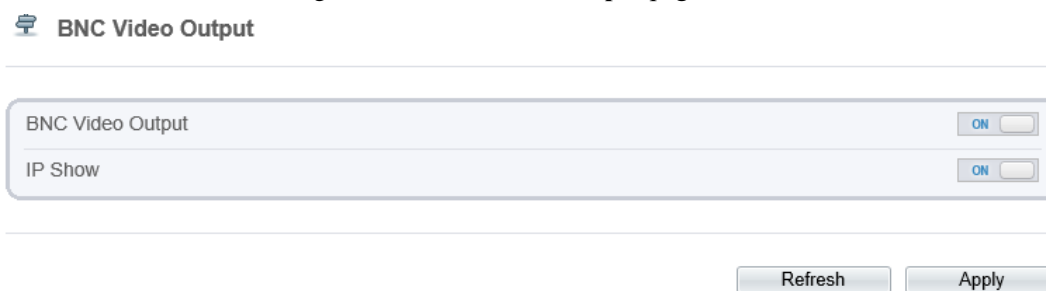

Step 2 Click the button on to enable **BNC Video Output**.

Step 3 Click **Apply**.

The message "Apply success!" is displayed. And the system saves the settings.

## 3.13 System Service

### Procedure

Step 1 Choose Configuration > Device > System.

The **System Service** page is displayed, as shown in Figure 3-13.

Figure 3-13 System Service page

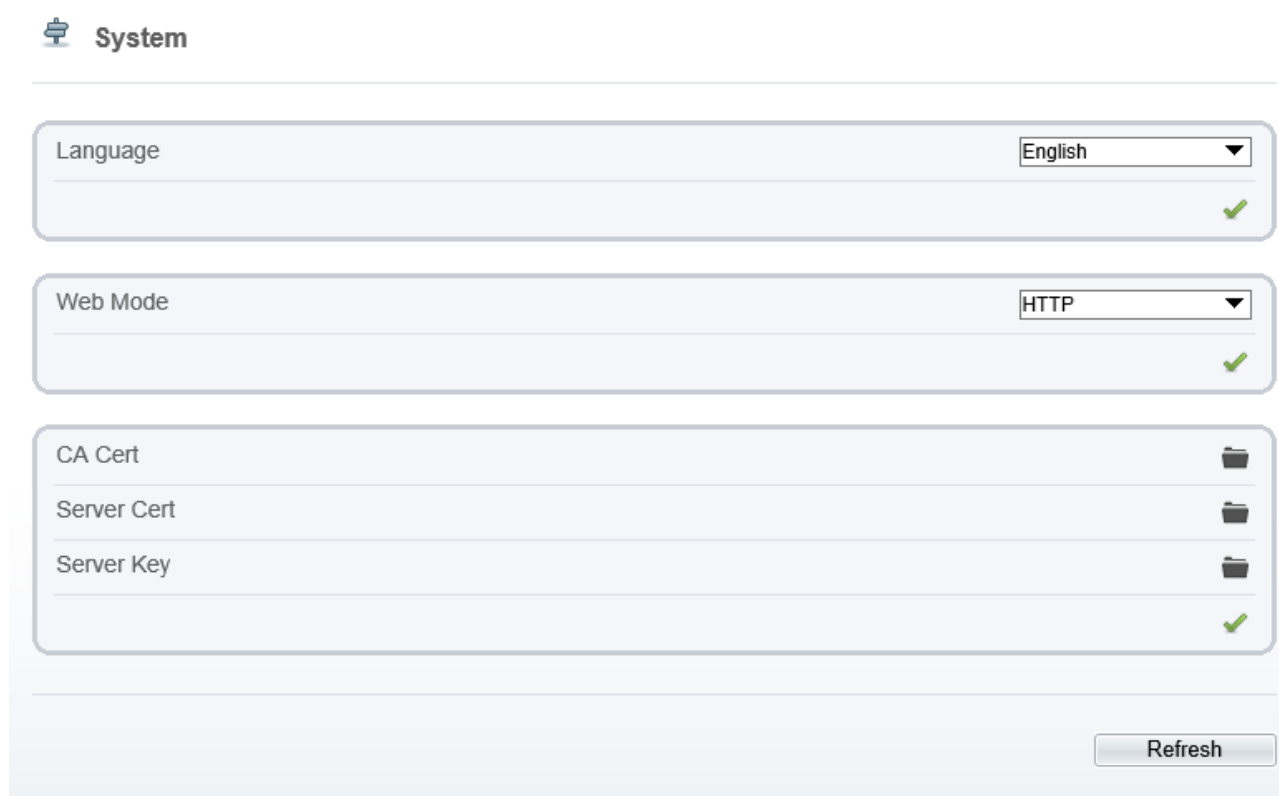

Step 2 Select an language from the **Language** drop-down list box.

Step 3 Click , the message "Apply success" is displayed.

Step 4 Click **OK**, the system saves the settings.

Step 5 Select a Web Mode from the **Web Mode** drop-down list box.

Step 6 Click , the message "This operation will lead to the device to restart, continue?" is displayed.

Step 7 Click **OK**, the device restarts and saves the settings automatically.

Step 8 Choose the CA cert, server cert, server cert, server key from the local folder,

Step 9 Click  to update the certificate.

## 3.14 Video Denoise (Only for Some Models)

### Description

On the **Voice Denoise** page, you can enable the Voice Denoise to reduce the effect of external environmental noise on the built-in MIC.

### Procedure

Step 1 Choose **Configuration > Device > Voice Denoise**

The **Voice Denoise** page is displayed, as shown in Figure 3-14.

Figure 3-14 Voice Denoise page

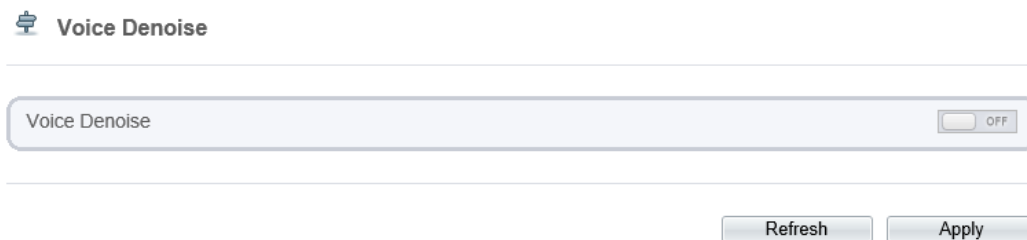

Step 2 Click the **Voice Denoise** button to enable the Voice Denoise.

Step 3 Click **Apply**.

The message "Apply success" is displayed, the system saves the setting.

## 3.15 Software Licenses

### Procedure

Step 1 Click Configuration > Device > Software Licenses.

The **Software Licenses** page is displayed, as shown in Figure 3-15.

Figure 3-15 Software licenses page

 **Software Licenses**

---

Open Source Software Licenses

[View Licenses](#)

Step 2 Click the view licenses, you can view the open source software licenses.

# 4 Configure External Devices

## 4.1 External PTZ Parameters(Only for Some Models)

### Description

When the IP camera is connected to an external PTZ, you can set external PTZ parameters, such as **PTZ Protocol**, **PTZ Address**, **Baud Rate**, and **Data Bits**.



### CAUTION

This function is available only for a camera connected to an external PTZ. The PTZ address must be set to the address of the external PTZ; otherwise, the external PTZ cannot be used.

### Procedure

Step 1 Choose Configuration > External Device > PTZ.

The **PTZ** page is displayed, as shown in Figure 4-1.

Figure 4-1 PTZ page

PTZ

Camera 1

PTZ  ON

PTZ Protocol PELCO\_D

PTZ Address 0

Serial Port COM1

Baud Rate 9600

Data Bits 8

Stop Bits 1

Parity Verification None

Refresh Apply

Step 2 Set the parameters according to Table 4-1.

**Table 4-1** PTZ parameters

Parameter	Description	Setting
PTZ	Enable this function if the device connects to an external PTZ.  NOTE This check box is dimmed for an IP dome camera.	[Setting method] Click the button on to enable PTZ configuration.
PTZ Protocol	Protocol used by the external PTZ, such as PELCO_D and PELCO_P.	[Setting method] Select a value from the drop-down list box.  NOTE When configure the external PTZ parameters, these parameters must match the settings on the external PTZ.
PTZ Address	Address of the external PTZ.	
Serial Port	The default value is <b>COM1</b> .	
Baud Rate	Baud rate used by the external PTZ. The value ranges from 300 bit/s to 115200 bit/s. The default value is <b>4800</b> bit/s.	
Data Bits	The value must match the setting used by the external PTZ. It can be set to a value ranging from 4 to 8. Generally, the value is 8.	
Stop Bits	N/A	
Parity Verification	N/A	

Step 3 Click **Apply**.

The message "Apply success!" is displayed, and the system saves the settings.

# 5 Configure Intelligent Analysis

## 5.1 Perimeter

### Description

The perimeter function refers to that an alarm is generated when target objects (such as person, car, and both person and car) enter the deployment area.

### Procedure

Step 1 Select **Intelligent Analysis > Perimeter** to access the **Perimeter** interface, as shown in Figure 5-1

Figure 5-1 Perimeter Setting Interface

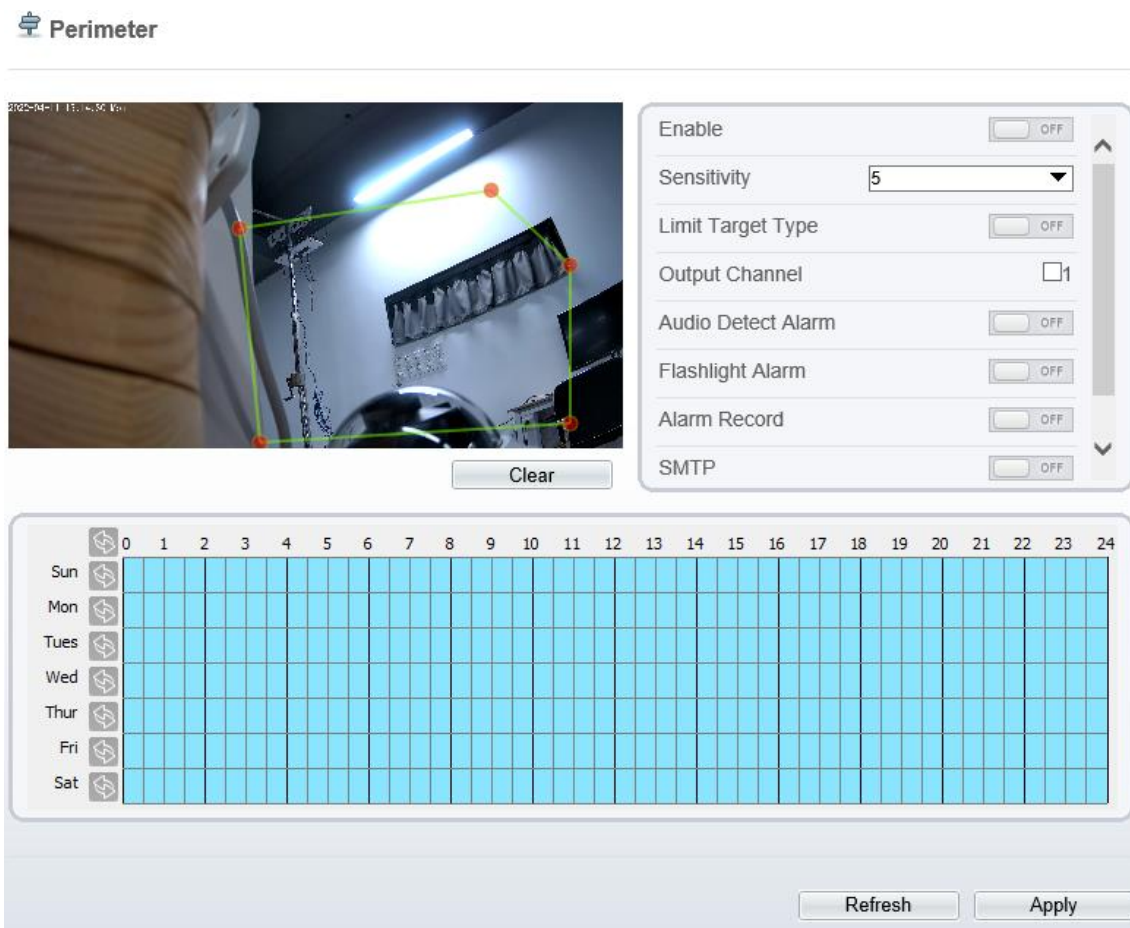

Step 2 Set all parameters for perimeter. Table 5-1 describes the specific parameters.

**Table 5-1** Perimeter Parameter Description

Parameter	Description	Setting
Enable	Enable the button to enable the alarm.	[How to set] Click Enable to enable. [Default value] OFF
Sensitivity	The sensitivity of detecting the target, when the value is high, the target can be detected easily, but the accuracy will be lower.	[How to set] Choose from the drop-down list [Default value] 5
Limit type	Enable to choose the limit type (person or car / person / car) from type drop-down list.	[How to set] Click Enable to enable. [Default value] OFF
Output Channel	If you check to set the Output Channel and the device is connected to an external alarm indicator, the alarm indicator signals when an alarm is triggered. Only for Some Models.	[How to set] Click to select an ID.
Audio Detect Alarm	Enable to choose the sound alarm file from type drop-down list. When it alarms the device will play alarm sound file. Only for some models.	[How to set] Click Enable to enable. [Default value] OFF
Flashlight Alarm	Enable to flashlight alarm when it triggers the alarm, the flashlight will flash. Only for some models.	[How to set] Click Enable to enable. [Default value] OFF
Alarm Record	Enable the button to enable the alarm record.	[How to set] Click to enable Alarm Record. [Default value] OFF
SMTP	Enable the button to enable SMTP sever. More details please refer to chapter 10.5	[How to set] Click to enable SMTP. [Default value] OFF

Parameter	Description	Setting
FTP Upload	Enable the button to enable File Transfer Protocol. More details please refer to chapter 10.6 .	[How to set] Click to enable FTP Upload. [Default value] OFF

### Step 3 Set a deployment area

Move the cursor to the drawing interface and click to generate a point, move the cursor to draw a line, and then click to generate another point. This is how a line is generated. In this way, continue to draw lines to form any shape, and right-click to finish line drawing, as shown in Figure 5-2.

Figure 5-2 Deployment Area Setting Interface



#### NOTE

- A drawn line cannot cross another one, or the line drawing fails.
- Any shape with 8 sides at most can be drawn.
- The quantity of deployment areas is not limited yet and will be described in future when a limit is applied.

### Step 4 Set deployment time

**Method 1:** Click left mouse button to select any time point within 0:00-24:00 from Monday to Sunday as shown in Figure 5-3.

**Method 2:** Hold down the left mouse button, drag and release mouse to select the deployment time within 0:00-24:00 from Monday to Sunday.

#### NOTE

When you select time by dragging the cursor, the cursor cannot be moved out of the time area. Otherwise, no time can be selected.

**Method 3:** Click  in the deployment time page to select the whole day or whole week.

**Deleting deployment time:** Click  again or inverse selection to delete the selected deployment time.

Figure 5-3 Deployment Time Setting Interface

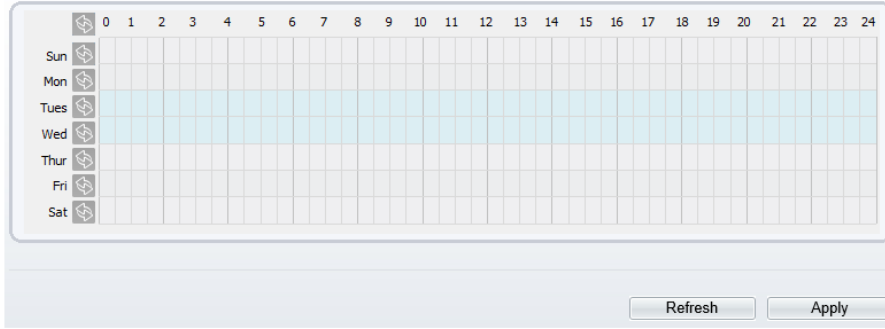

## 5.2 Single Virtual Fence

### Description

A single virtual fence is a line that is set at a concerned position within the monitored field of view and specifies the forbidden travel direction, an alarm is generated when target objects (such as person or car) cross this line.

### Procedure

- Step 1 Select **Intelligent Analysis** > **Single Virtual Fence** to access the **Single Virtual Fence** setting interface, as shown in Figure 5-4.

Figure 5-4 Single Virtual Fence Setting Interface

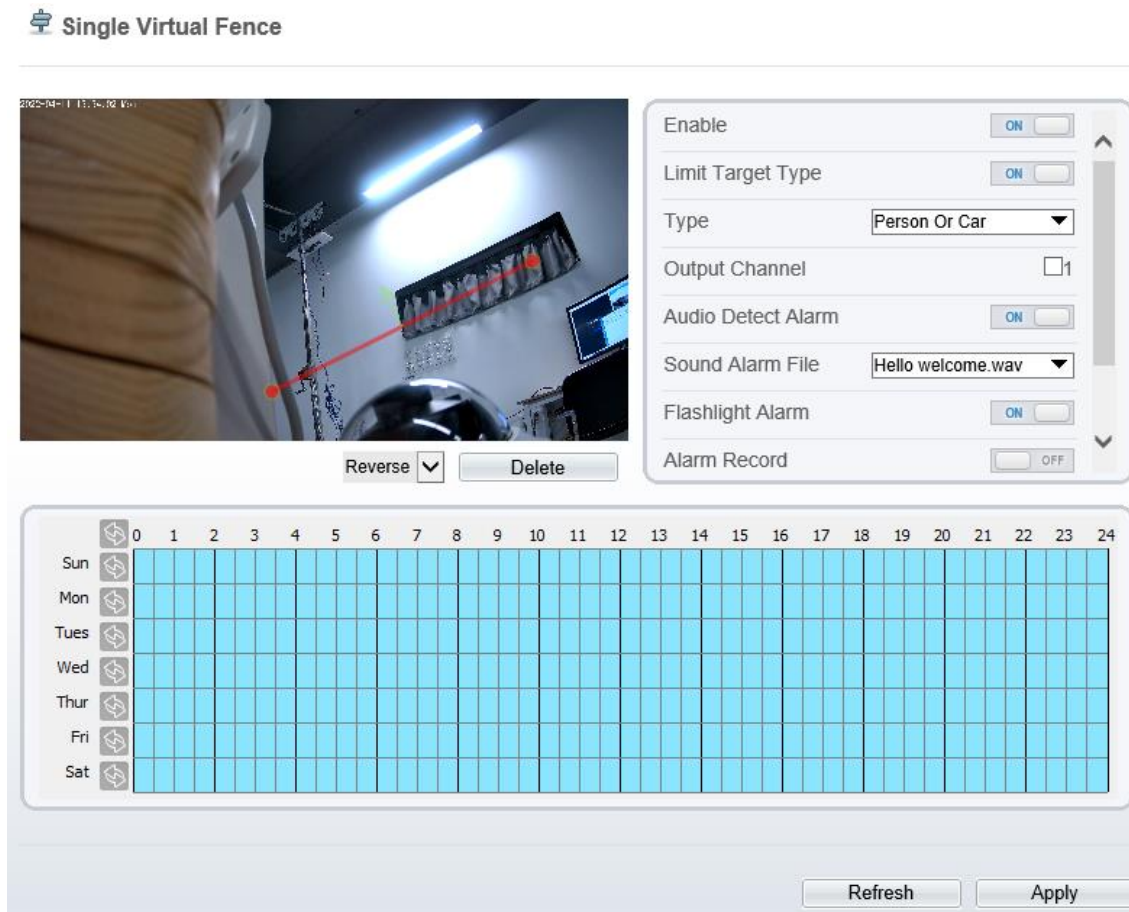

Step 2 Set all parameters for the single virtual fence. Table 5-2 describes the specific parameters.

**Table 5-2** Description of Parameters for Single Virtual Fence

Parameter	Description	Setting
Enable	Enable the button to enable the alarm.	[How to set] Click Enable to enable [Default value] OFF
Sensitivity	The sensitivity of detecting the target, when the value is high, the target can be detected easily, but the accuracy will be lower.	[How to set] Choose from the drop-down list [Default value] 5
Limit type	Enable to choose the limit type (person or car / person / car) from type drop-down list.	[How to set] Click Enable to enable. [Default value] OFF
Output Channel	If you check to set the Output Channel and the device is connected to an external alarm indicator, the alarm indicator signals when an alarm is triggered. Only for some models.	[How to set] Click to select an ID.
Audio Detect Alarm	Enable to choose the sound alarm file from type drop-down list. When it alarms the device will play alarm sound file. Only for some models.	[How to set] Click Enable to enable. [Default value] OFF
Flashlight Alarm	Enable to flashlight alarm when it triggers the alarm, the flashlight will flash. Only for some models.	[How to set] Click Enable to enable. [Default value] OFF
Alarm Record	Enable the button to enable the alarm record.	[How to set] Click to enable Alarm Record. [Default value] OFF
SMTP	Enable the button to enable SMTP sever. Details please refer to chapter 10.5	[How to set] Click to enable SMTP. [Default value] OFF
FTP Upload	Enable the button to enable File Transfer Protocol. Details please refer to chapter 10.6.	[How to set] Click to enable FTP. [Default value] OFF

Step 3 Set a deployment area

**Drawing a line:** Move the cursor to the drawing interface, hold down the left mouse button, and move the cursor to draw a line. When you release the left mouse button, a single virtual fence is generated.

**Setting a single virtual fence:** Click a line (and the trip line turns red) to select the single virtual fence and set its direction as **positive**, **reverse** or **bidirectional**, or **delete the selected** line. You can also press and hold left mouse button at the endpoint of a single virtual fence and move the mouse to modify the position and length of this single virtual fence. You can right-click to delete the single virtual fence, as shown in Figure 5-5.

Figure 5-5 Deployment Area Setting Interface

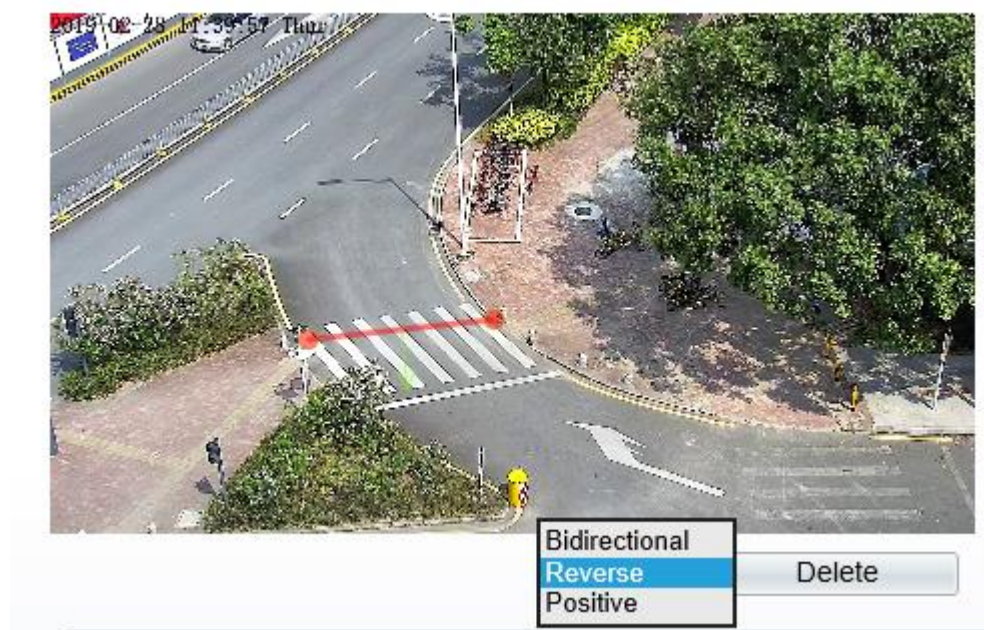

**NOTE**

- A single virtual fence is not within any deployment area, therefore, when an alarm is generated, the trace always exists. Only when the target object moves out of the field of view, the trace disappears.
- Try to draw the single virtual fence in the middle, because the recognition of a target takes time after target appearance on the screen and an alarm is generated only when the object is recognized to have crossed the single virtual fence.
- The single virtual fence which detects person foot as the recognition target cannot be too short, because a short single virtual fence tends to miss targets.

Step 4 Set deployment time

For more details, please refer to *5.1 Step 4*

## 5.3 Double Virtual Fences

### Description

Double virtual fences refer to two lines that are set at a concerned special position within the field of view and specify the forbidden travel direction. when target objects (such as person or car) move along the set travel direction and cross these lines in a certain order (line 1 followed by line 2) in pass max time, an alarm is generated.

## Procedure

- Step 1 Select **Intelligent Analysis > Double Virtual Fences** to access the **Double Virtual Fences** setting interface, as shown in Figure 5-6.

Figure 5-6 Double Virtual Fences Setting Interface

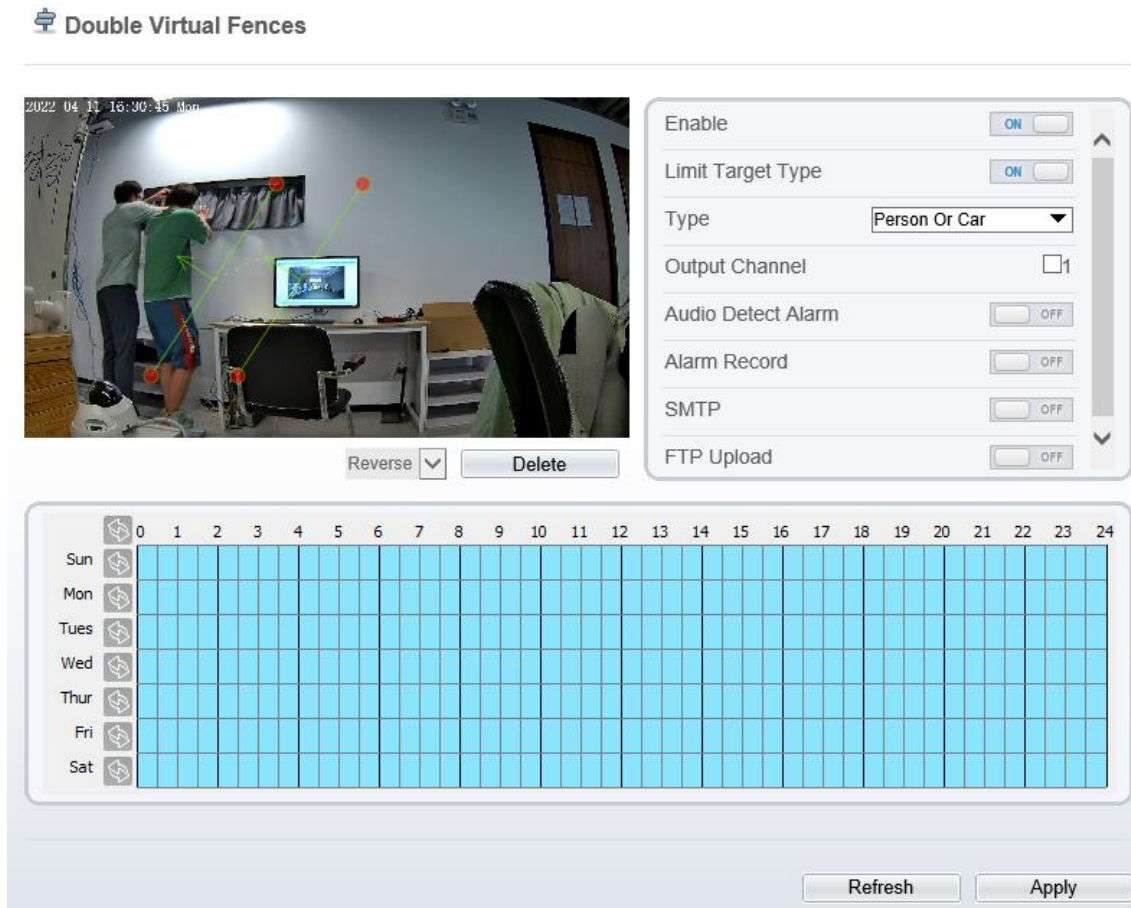

- Step 2 Set all parameters for the double virtual fences. Table 5-3 describes the specific parameters.

**Table 5-3** Description of Parameters for Double Virtual Fence

Parameter	Description	Setting
Enable	Enable the button to enable the alarm.	[How to set] Click to enable. [Default value] OFF
Limit type	Enable to choose the limit type (person or car / person / car) from type drop-down list.	[How to set] Click Enable to enable. [Default value] OFF
Output Channel	If you check to set the Output Channel and the device is connected to an external alarm indicator, the alarm indicator signals when an alarm is triggered. Only for some models.	[How to set] Click to select an ID.

Parameter	Description	Setting
Audio Detect Alarm	Enable to choose the sound alarm file from type drop-down list. When it alarms the device will play alarm sound file. Only for some models.	[How to set] Click Enable to enable. [Default value] OFF
Flashlight Alarm	Enable to flashlight alarm when it triggers the alarm, the flashlight will flash. Only for some models.	[How to set] Click Enable to enable. [Default value] OFF
Alarm Record	Enable the button to enable the alarm record.	[How to set] Click to enable Alarm Record. [Default value] OFF
SMTP	Enable the button to enable SMTP sever. For more details, please refer to chapter 10.5	[How to set] Click to enable SMTP. [Default value] OFF
FTP Upload	Enable the button to enable File Transfer Protocol. For more details, please refer to chapter 10.6 .	[How to set] Click to enable FTP. [Default value] OFF

### Step 3 Set a deployment area

**Drawing a line:** Move the cursor to the drawing interface, hold down the left mouse button, and move the cursor to draw two lines. When you release the left mouse button, two numbered virtual fences are generated. Choose either of the double virtual fences to set the direction to Positive or Reverse.

**Setting double virtual fences:** Click one of the double virtual fences (and the virtual fence turns red) to select this virtual fence and set the direction to **Positive** or **Reverse**, or delete the selected line. You can also press and hold left mouse button at the endpoint of a virtual fence and move the mouse to modify the position and length of this virtual fence. You can right-click to delete the double virtual fences, as shown in Figure 5-7.

Figure 5-7 Deployment Area Setting Interface



 **NOTE**

- The two virtual fences are in sequential order. An alarm is generated only when a target crosses virtual fence 1 and then virtual fence 2 within the set maximum passing time.
- The double virtual fences are not within any deployment area, therefore, when an alarm is generated, the trace always exists. Only when the target object moves out of the field of view, the trace disappears.
- Try to draw double virtual fences in the middle, because the recognition of a target takes time after target appearance on the screen and an alarm is generated only when the object is recognized to have crossed the double virtual fences.
- The double virtual fences which detect person foot as the recognition target cannot be too short, because short double virtual fences tend to miss targets.

Step 4 Set deployment time

More details please refer to *5.1 Step 4*

## 5.4 Multiple Loiter

### Description

Multiple loiter allows setting the shortest loitering time for multiple targets of specified type (such as person or car) within the deployment area in the field of view. When the loitering time of the multiple targets within this area meets the set shortest loitering time, an alarm is generated.

## Procedure

Step 1 Select **Intelligent Analysis** > **Multi Loiter** to access the **Multi Loiter** setting interface, as shown in Figure 5-8.

Figure 5-8 Multi Loiter Setting Interface

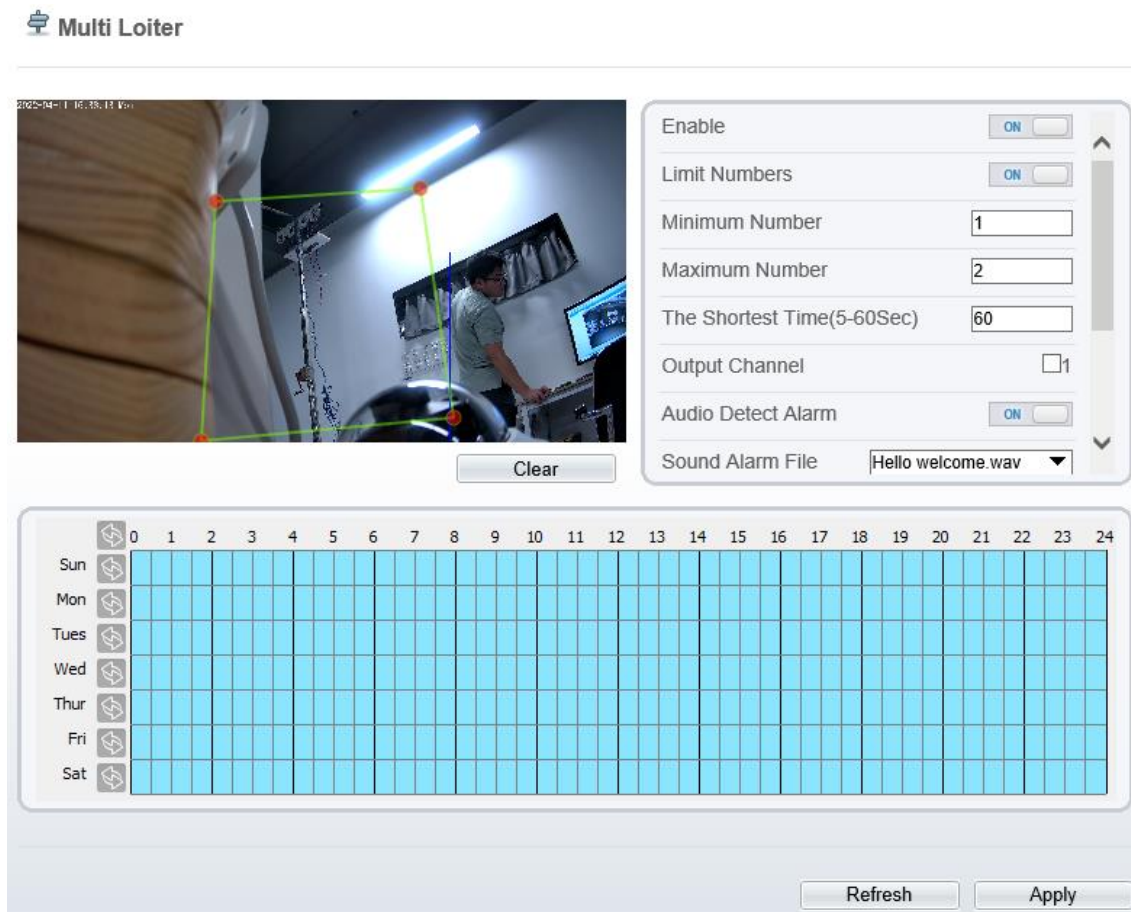

Step 2 Set all parameters for multiple loitering. Table 5-4 describes the specific parameters.

Table 5-4 Multiple Loitering Parameter Description

Parameter	Description	Setting
Enable	Enable the button to enable the alarm.	[How to set] Click Enable to enable. [Default value] OFF
Limit Numbers	When Limit Numbers is set to OFF, an alarm is generated no matter how many people loiter. When Limit Numbers is set to ON, if the minimum number is set to 2 and the maximum number is set to 3, an alarm is generated for 2-3 people loitering. Other settings are the same as loitering.	[How to set] Click to enable Limit Numbers.

Parameter	Description	Setting
The Shortest Time (Sec)	The time that a target object spends in loitering cannot be less than the shortest loitering time. Setting range: 5-60 seconds.	[How to set] Input a value in the area box. [Default value] 10s
Output Channel	If you check to set the Output Channel and the device is connected to an external alarm indicator, the alarm indicator signals when an alarm is triggered. Only for some models	[How to set] Click to select an ID.
Audio Detect Alarm	Enable to choose the sound alarm file from type drop-down list. When it alarms the device will play alarm sound file. Only for some models.	[How to set] Click Enable to enable. [Default value] OFF
Flashlight Alarm	Enable to flashlight alarm when it triggers the alarm, the flashlight will flash. Only for some models.	[How to set] Click Enable to enable. [Default value] OFF
Alarm Record	Enable the button to enable the alarm record.	[How to set] Click to enable Alarm Record. [Default value] OFF
SMTP	Enable the button to enable SMTP sever. For more details, please refer to chapter 10.5	[How to set] Click to enable SMTP. [Default value] OFF
FTP Upload	Enable the button to enable File Transfer Protocol. For more details please refer to chapter 10.6	[How to set] Click to enable FTP Upload. [Default value] OFF

### Step 3 Set a deployment area

Move the cursor to the drawing interface and click to generate a point, move the cursor to draw a line, and then click to generate another point. This is how a line is generated. In this way, continue to draw lines to form any shape, and right-click to finish line drawing, as shown in Figure 5-9.

Figure 5-9 Deployment Area Setting Interface



#### NOTE

- A drawn line cannot cross another one, or the line drawing fails.
- Any shape with 8 sides at most can be drawn .
- The quantity of deployment areas is not limited yet and will be described in future when a limit is applied.

### Step 4 Set deployment time

For more details please refer to *5.1 Step 4*.

## 5.5 Converse

### Description

Converse allows setting the travel direction criteria for a target within an area on the video screen. When a target of specified type (such as people or car) within this area moves in the set travel direction, an alarm is generated.

## Procedure

Step 1 Select **Intelligent Analysis > Converse** to access the **Converse** setting interface, as shown in Figure 5-10.

Figure 5-10 Converse Setting Interface

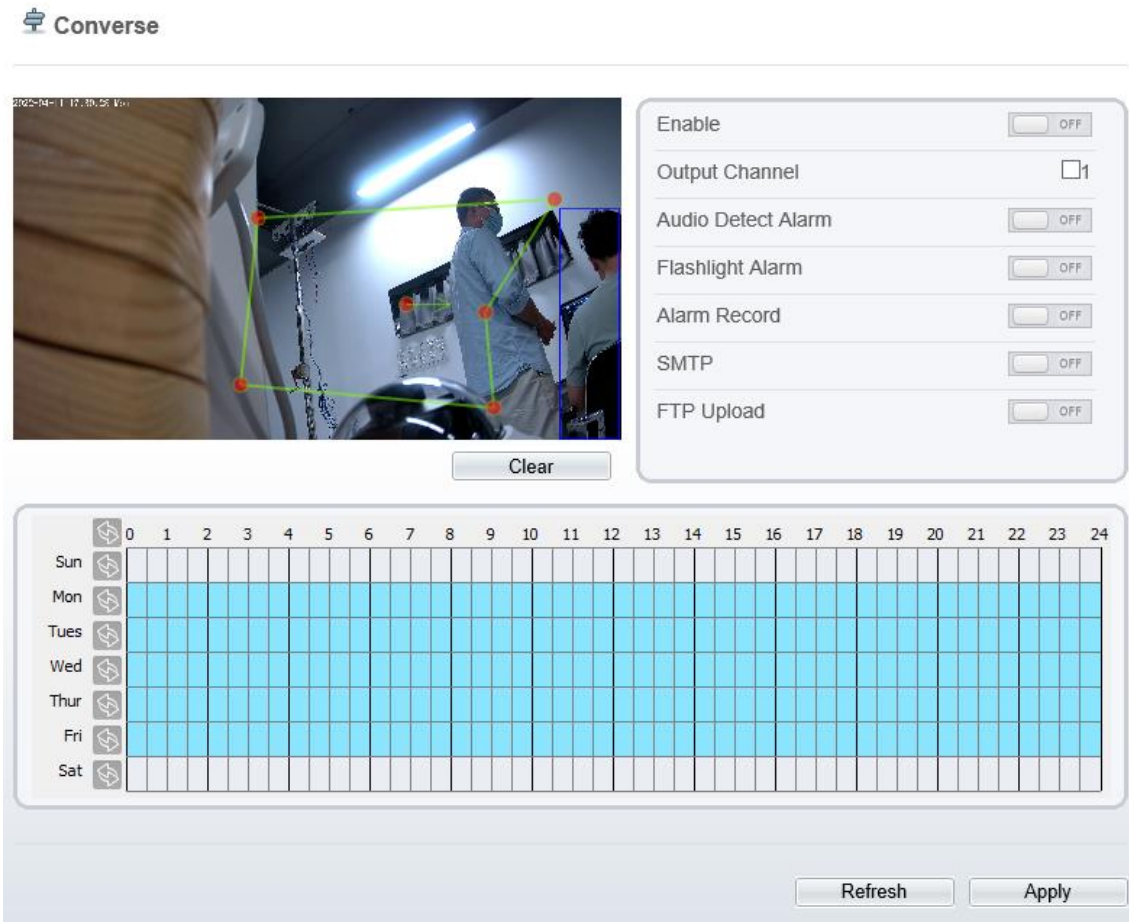

Step 2 Set all parameters for converse. Table 5-5 describes the specific parameters.

**Table 5-5** Converse Parameter Description

Parameter	Description	Setting
Enable	Enable the button to enable the alarm.	[How to set] Click Enable to enable. [Default value] OFF
Output Channel	If you check to set the Output Channel and the device is connected to an external alarm indicator, the alarm indicator signals when an alarm is triggered. Only for Some Models	[How to set] Click to select an ID.

Parameter	Description	Setting
Audio Detect Alarm	Enable to choose the sound alarm file from type drop-down list. When it alarms the device will play alarm sound file. Only for Some Models.	[How to set] Click Enable to enable. [Default value] OFF
Flashlight Alarm	Enable to flashlight alarm when it triggers the alarm, the flashlight will flash. Only for Some Models.	[How to set] Click Enable to enable. [Default value] OFF
Alarm Record	Enable the button to enable the alarm record.	[How to set] Click to enable Alarm Record. [Default value] OFF
SMTP	Enable the button to enable SMTP sever. More details, please refer to chapter 10.5	[How to set] Click to enable SMTP. [Default value] OFF
FTP Upload	Enable the button to enable File Transfer Protocol. For more details, please refer to chapter 10.6	[How to set] Click to enable FTP Upload. [Default value] OFF

### Step 3 Set a deployment area

Move the cursor to the drawing interface and click to generate a point, move the cursor to draw a line, and then click to generate another point. This is how a line is generated. In this way, continue to draw lines to form any shape, and right-click to finish line drawing, move the arrow in the field can set the direction of converse. as shown in Figure 5-11.

Figure 5-11 Deployment Area Setting Interface

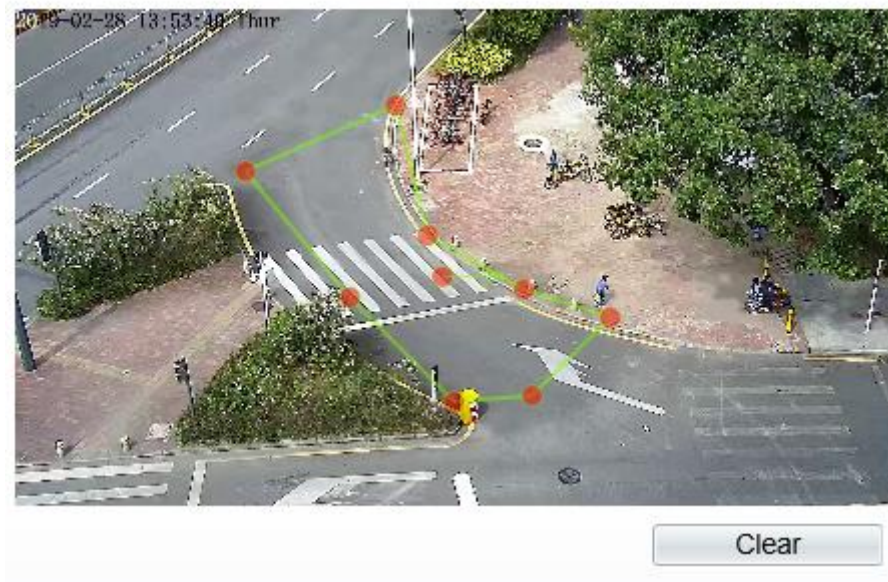

 **NOTE**

- A drawn line cannot cross another one, or the line drawing fails.
- Any shape with 8 sides at most can be drawn .
- The quantity of deployment areas is not limited yet and will be described in future when a limit is applied.

**Step 4** Set deployment time

For more details, please refer to *5.1 Step 4*.

## 5.6 Personnel Count (Only for Some Models)

User can draw line to count the number of people at the special area.

### Procedure

- Step 1** Select **Intelligent Analysis** > **Personnel Count** to access the **Personnel Count** setting interface, as shown in Figure 5-12.

Figure 5-12 Personnel count

**Personnel Count**



2021-06-15 11:35:51 Sun  
 1. 34.88  
 2. 35.07  
 3. 35.15

Clear

Enable  ON

OSD Enable  ON

Counting Clear Interval 1Day

Clear Counting

Area Type Line

A->B Out

B->A In

Set Correction Value  OFF

	0	1	2	3	4	5	6	7	8	9	10	11	12	13	14	15	16	17	18	19	20	21	22	23	24
Sun	<input type="checkbox"/>	<input type="checkbox"/>	<input type="checkbox"/>	<input type="checkbox"/>	<input type="checkbox"/>	<input type="checkbox"/>	<input type="checkbox"/>	<input type="checkbox"/>	<input type="checkbox"/>	<input type="checkbox"/>	<input type="checkbox"/>	<input type="checkbox"/>	<input type="checkbox"/>	<input type="checkbox"/>	<input type="checkbox"/>	<input type="checkbox"/>	<input type="checkbox"/>	<input type="checkbox"/>	<input type="checkbox"/>	<input type="checkbox"/>	<input type="checkbox"/>	<input type="checkbox"/>	<input type="checkbox"/>	<input type="checkbox"/>	<input type="checkbox"/>
Mon	<input type="checkbox"/>	<input type="checkbox"/>	<input type="checkbox"/>	<input type="checkbox"/>	<input type="checkbox"/>	<input type="checkbox"/>	<input type="checkbox"/>	<input type="checkbox"/>	<input type="checkbox"/>	<input type="checkbox"/>	<input type="checkbox"/>	<input type="checkbox"/>	<input type="checkbox"/>	<input type="checkbox"/>	<input type="checkbox"/>	<input type="checkbox"/>	<input type="checkbox"/>	<input type="checkbox"/>	<input type="checkbox"/>	<input type="checkbox"/>	<input type="checkbox"/>	<input type="checkbox"/>	<input type="checkbox"/>	<input type="checkbox"/>	<input type="checkbox"/>
Tues	<input type="checkbox"/>	<input type="checkbox"/>	<input type="checkbox"/>	<input type="checkbox"/>	<input type="checkbox"/>	<input type="checkbox"/>	<input type="checkbox"/>	<input type="checkbox"/>	<input type="checkbox"/>	<input type="checkbox"/>	<input type="checkbox"/>	<input type="checkbox"/>	<input type="checkbox"/>	<input type="checkbox"/>	<input type="checkbox"/>	<input type="checkbox"/>	<input type="checkbox"/>	<input type="checkbox"/>	<input type="checkbox"/>	<input type="checkbox"/>	<input type="checkbox"/>	<input type="checkbox"/>	<input type="checkbox"/>	<input type="checkbox"/>	<input type="checkbox"/>
Wed	<input type="checkbox"/>	<input type="checkbox"/>	<input type="checkbox"/>	<input type="checkbox"/>	<input type="checkbox"/>	<input type="checkbox"/>	<input type="checkbox"/>	<input type="checkbox"/>	<input type="checkbox"/>	<input type="checkbox"/>	<input type="checkbox"/>	<input type="checkbox"/>	<input type="checkbox"/>	<input type="checkbox"/>	<input type="checkbox"/>	<input type="checkbox"/>	<input type="checkbox"/>	<input type="checkbox"/>	<input type="checkbox"/>	<input type="checkbox"/>	<input type="checkbox"/>	<input type="checkbox"/>	<input type="checkbox"/>	<input type="checkbox"/>	<input type="checkbox"/>
Thur	<input type="checkbox"/>	<input type="checkbox"/>	<input type="checkbox"/>	<input type="checkbox"/>	<input type="checkbox"/>	<input type="checkbox"/>	<input type="checkbox"/>	<input type="checkbox"/>	<input type="checkbox"/>	<input type="checkbox"/>	<input type="checkbox"/>	<input type="checkbox"/>	<input type="checkbox"/>	<input type="checkbox"/>	<input type="checkbox"/>	<input type="checkbox"/>	<input type="checkbox"/>	<input type="checkbox"/>	<input type="checkbox"/>	<input type="checkbox"/>	<input type="checkbox"/>	<input type="checkbox"/>	<input type="checkbox"/>	<input type="checkbox"/>	<input type="checkbox"/>
Fri	<input type="checkbox"/>	<input type="checkbox"/>	<input type="checkbox"/>	<input type="checkbox"/>	<input type="checkbox"/>	<input type="checkbox"/>	<input type="checkbox"/>	<input type="checkbox"/>	<input type="checkbox"/>	<input type="checkbox"/>	<input type="checkbox"/>	<input type="checkbox"/>	<input type="checkbox"/>	<input type="checkbox"/>	<input type="checkbox"/>	<input type="checkbox"/>	<input type="checkbox"/>	<input type="checkbox"/>	<input type="checkbox"/>	<input type="checkbox"/>	<input type="checkbox"/>	<input type="checkbox"/>	<input type="checkbox"/>	<input type="checkbox"/>	<input type="checkbox"/>
Sat	<input type="checkbox"/>	<input type="checkbox"/>	<input type="checkbox"/>	<input type="checkbox"/>	<input type="checkbox"/>	<input type="checkbox"/>	<input type="checkbox"/>	<input type="checkbox"/>	<input type="checkbox"/>	<input type="checkbox"/>	<input type="checkbox"/>	<input type="checkbox"/>	<input type="checkbox"/>	<input type="checkbox"/>	<input type="checkbox"/>	<input type="checkbox"/>	<input type="checkbox"/>	<input type="checkbox"/>	<input type="checkbox"/>	<input type="checkbox"/>	<input type="checkbox"/>	<input type="checkbox"/>	<input type="checkbox"/>	<input type="checkbox"/>	<input type="checkbox"/>

Refresh Apply

Over People Number Alarm  OFF

Alarm Threshold 1000

Output Channel  1

Audio Detect Alarm  OFF

Flashlight Alarm  OFF

Alarm Record  OFF

SMTP  OFF

FTP Upload  OFF

Step 2 Set all parameters for illegal parking. Table 5-6 describes the specific parameters.

**Table 5-6** Description of Parameters for Personnel Count

Parameter	Description	Setting
Enable	Enable the button to enable the alarm.	[How to set] Click Enable to enable. [Default value] OFF
OSD Enable	Enable the OSD, the count data will show on live video screen.	[How to set] Click Enable to enable. [Default value] OFF
Counting Clear Interval	The camera will clear counting data at the setting interval. Click the “Clear Counting”, clearing the data immediately.	[How to set] Choose from drop-down list. [Default value] 12 hours
Area Type	Draw a line on live video screen. The label of A and B indicate out and in.	[How to set] Choose from drop-down list. [Default value] Line
Set Correction Value	Enable, set the count correction value, it can be positive or negative. For example, if there are 30 people enter the area before counting, input 30 to correct. If 30 people go out the area, input -30.	[How to set] Enable /Input a value in the area box. [Default value] 0
Over People Number Alarm	Enable, if the counting number is passing the threshold, it will alarm.	[How to set] Click Enable to enable. [Default value] OFF
Alarm Threshold	The threshold of enable alarm.	[How to set] Enable /Input a value in the area box. [Default value] 1000
Output Channel	If you check to set the Output Channel and the device is connected to an external alarm indicator, the alarm indicator signals when an alarm is triggered. Only for Some Models.	[How to set] Click to select an ID.
Audio Detect Alarm	Enable to choose the sound alarm file from type drop-down list. When it alarms the device will play alarm sound file. Only for Some Models.	[How to set] Click Enable to enable. [Default value] OFF

Parameter	Description	Setting
Flashlight Alarm	Enable to flashlight alarm when it triggers the alarm, the flashlight will flash. Only for Some Models.	[How to set] Click Enable to enable. [Default value] OFF
Alarm Record	Enable the button to enable the alarm record.	[How to set] Click to enable Alarm Record. [Default value] OFF
SMTP	Enable the button to enable SMTP sever. The parameters of SMTP can be set at <b>Configuration &gt; Network Service &gt; SMTP</b> interface.	[How to set] Click to enable SMTP. [Default value] OFF
FTP Upload	Enable the button to enable File Transfer Protocol. The parameters of FTP can be set at <b>Configuration &gt; Network Service &gt; FTP</b> interface.	[How to set] Click to enable FTP Upload. [Default value] OFF

### Step 3 Set a deployment area

Move the cursor to the drawing interface and click to generate a point, move the cursor to draw a line, and then click to generate another point. This is how a line is generated. In this way, continue to draw lines to form any shape, and right-click to finish line drawing.

### Step 4 Set deployment time

For more details please refer to *5.1 Step 4..*

# 6 Configure the Alarm Function

The different cameras may have different alarm linkage actions, it depends on the performance of cameras, please refer to actual products.

## 6.1 Alarm Output (Only for Some Models)

### Procedure

Step 1 Choose **Configuration > Alarm > Alarm Output**.

The **Alarm Output** page is displayed, as shown in Figure 6-1.

Figure 6-1 Alarm Output page

 **Alarm Output**

---

Alarm Output 1 ▼

Name

Valid Signal Close ▼

Alarm Output Mode Switch Mode ▼

Alarm Time(ms)(0:Continuous) 0

Timing Alarm Output ON

	0	1	2	3	4	5	6	7	8	9	10	11	12	13	14	15	16	17	18	19	20	21	22	23	24
Sun	<input type="checkbox"/>	<input type="checkbox"/>	<input type="checkbox"/>	<input type="checkbox"/>	<input type="checkbox"/>	<input type="checkbox"/>	<input type="checkbox"/>	<input type="checkbox"/>	<input type="checkbox"/>	<input type="checkbox"/>	<input type="checkbox"/>	<input type="checkbox"/>	<input type="checkbox"/>	<input type="checkbox"/>	<input type="checkbox"/>	<input type="checkbox"/>	<input type="checkbox"/>	<input type="checkbox"/>	<input type="checkbox"/>	<input type="checkbox"/>	<input type="checkbox"/>	<input type="checkbox"/>	<input type="checkbox"/>	<input type="checkbox"/>	<input type="checkbox"/>
Mon	<input type="checkbox"/>	<input type="checkbox"/>	<input type="checkbox"/>	<input type="checkbox"/>	<input type="checkbox"/>	<input type="checkbox"/>	<input type="checkbox"/>	<input type="checkbox"/>	<input type="checkbox"/>	<input type="checkbox"/>	<input type="checkbox"/>	<input type="checkbox"/>	<input type="checkbox"/>	<input type="checkbox"/>	<input type="checkbox"/>	<input type="checkbox"/>	<input type="checkbox"/>	<input type="checkbox"/>	<input type="checkbox"/>	<input type="checkbox"/>	<input type="checkbox"/>	<input type="checkbox"/>	<input type="checkbox"/>	<input type="checkbox"/>	<input type="checkbox"/>
Tues	<input type="checkbox"/>	<input type="checkbox"/>	<input type="checkbox"/>	<input type="checkbox"/>	<input type="checkbox"/>	<input type="checkbox"/>	<input type="checkbox"/>	<input type="checkbox"/>	<input type="checkbox"/>	<input type="checkbox"/>	<input type="checkbox"/>	<input type="checkbox"/>	<input type="checkbox"/>	<input type="checkbox"/>	<input type="checkbox"/>	<input type="checkbox"/>	<input type="checkbox"/>	<input type="checkbox"/>	<input type="checkbox"/>	<input type="checkbox"/>	<input type="checkbox"/>	<input type="checkbox"/>	<input type="checkbox"/>	<input type="checkbox"/>	<input type="checkbox"/>
Wed	<input type="checkbox"/>	<input type="checkbox"/>	<input type="checkbox"/>	<input type="checkbox"/>	<input type="checkbox"/>	<input type="checkbox"/>	<input type="checkbox"/>	<input type="checkbox"/>	<input type="checkbox"/>	<input type="checkbox"/>	<input type="checkbox"/>	<input type="checkbox"/>	<input type="checkbox"/>	<input type="checkbox"/>	<input type="checkbox"/>	<input type="checkbox"/>	<input type="checkbox"/>	<input type="checkbox"/>	<input type="checkbox"/>	<input type="checkbox"/>	<input type="checkbox"/>	<input type="checkbox"/>	<input type="checkbox"/>	<input type="checkbox"/>	<input type="checkbox"/>
Thur	<input type="checkbox"/>	<input type="checkbox"/>	<input type="checkbox"/>	<input type="checkbox"/>	<input type="checkbox"/>	<input type="checkbox"/>	<input type="checkbox"/>	<input type="checkbox"/>	<input type="checkbox"/>	<input type="checkbox"/>	<input type="checkbox"/>	<input type="checkbox"/>	<input type="checkbox"/>	<input type="checkbox"/>	<input type="checkbox"/>	<input type="checkbox"/>	<input type="checkbox"/>	<input type="checkbox"/>	<input type="checkbox"/>	<input type="checkbox"/>	<input type="checkbox"/>	<input type="checkbox"/>	<input type="checkbox"/>	<input type="checkbox"/>	<input type="checkbox"/>
Fri	<input type="checkbox"/>	<input type="checkbox"/>	<input type="checkbox"/>	<input type="checkbox"/>	<input type="checkbox"/>	<input type="checkbox"/>	<input type="checkbox"/>	<input type="checkbox"/>	<input type="checkbox"/>	<input type="checkbox"/>	<input type="checkbox"/>	<input type="checkbox"/>	<input type="checkbox"/>	<input type="checkbox"/>	<input type="checkbox"/>	<input type="checkbox"/>	<input type="checkbox"/>	<input type="checkbox"/>	<input type="checkbox"/>	<input type="checkbox"/>	<input type="checkbox"/>	<input type="checkbox"/>	<input type="checkbox"/>	<input type="checkbox"/>	<input type="checkbox"/>
Sat	<input type="checkbox"/>	<input type="checkbox"/>	<input type="checkbox"/>	<input type="checkbox"/>	<input type="checkbox"/>	<input type="checkbox"/>	<input type="checkbox"/>	<input type="checkbox"/>	<input type="checkbox"/>	<input type="checkbox"/>	<input type="checkbox"/>	<input type="checkbox"/>	<input type="checkbox"/>	<input type="checkbox"/>	<input type="checkbox"/>	<input type="checkbox"/>	<input type="checkbox"/>	<input type="checkbox"/>	<input type="checkbox"/>	<input type="checkbox"/>	<input type="checkbox"/>	<input type="checkbox"/>	<input type="checkbox"/>	<input type="checkbox"/>	<input type="checkbox"/>

Manual control Start Stop

Refresh Apply

Step 2 Set the parameters according to Table 6-1.

**Table 6-1** Alarm I/O parameters

Parameter	Description	Setting
Alarm Output	ID of the alarm output channel. NOTE The number of alarm output channels depends on the device model.	[Setting method] Select a value from the drop-down list box. [Default value] 1
Name	Alarm output channel name.	[Value range] 0 to 32 bytes
Valid Signal	The options are as follows: <ul style="list-style-type: none"> <li>• <b>Close:</b> An alarm is generated when an external alarm signal is received.</li> <li>• <b>Open:</b> An alarm is generated when no external alarm signal is received.</li> </ul>	[Setting method] Select a value from the drop-down list box. [Default value] Close
Alarm Output Mode	When the device receives I/O alarm signals, the device sends the alarm information to an external alarm device in the mode specified by this parameter. The options include the switch mode and pulse mode. NOTE <ul style="list-style-type: none"> <li>• If the switch mode is used, the alarm frequency of the device must be the same as that of the external alarm device.</li> <li>• If the pulse mode is used, the alarm frequency of the external alarm device can be configured.</li> </ul>	[Setting method] Select a value from the drop-down list box. [Default value] Switch Mode
Alarm Time (ms) (0: Continuous)	Alarm output duration. The value <b>0</b> indicates that the alarm remains valid.	[Setting method] Enter a value manually. [Default value] 0 [Value range] 0 to 86400 seconds
Timing Alarm Output	Enable timing alarm output, set the schedule to time alarm	[Setting method] Enable [Default value] OFF
Manual Control	Control the alarm output.	N/A

Step 3 Click **Apply**.

The message "Apply success!" is displayed, and the system saves the settings.

## 6.2 Disk Alarm

### Procedure

Step 1 Choose **Configuration > Alarm > Disk Alarm**.

The **Disk Alarm** page is displayed, as shown in Figure 6-2.

Figure 6-2 Disk Alarm page

**Disk Alarm**

Disk Full Alarm  OFF

Alarm Interval(10-86400S)

Output Channel  1  2

Alarm Record  OFF

Refresh Apply

Step 2 Click the button on to enable disk alarm.

Step 3 Configure the **alarm interval** parameters.

Step 4 Select **Out channel** number (Please refer to the actual product).

Step 5 Click **Apply**.

The message "Apply success!" is displayed, and the system saves the settings.

## 6.3 Network Alarm

### Procedure

Step 1 Choose **Configuration > Alarm > Network Alarm**.

The **Network Alarm** page is displayed, as shown in Figure 6-3.

Figure 6-3 Network Alarm page

**Network Alarm**

Network Card ID

Exceptional Alarm  ON

Alarm Interval(10-86400S)

Output Channel  1  2

Alarm Record  OFF

Refresh Apply

- Step 2 Click the button on to enable exceptional alarm.
- Step 3 Configure the network exceptional alarm interval.
- Step 4 Select **Out Channel** number.
- Step 5 Click **Apply**.

The message "Apply success!" is displayed, the system saves the settings.

## 6.4 Day Night Switch Alarm

### Description

At the setting time, enable the day night switch alarm, when it happens day night switched, it will send alarm signal.

### Procedure

- Step 1 Choose Configuration > Alarm > Day Night Switch Alarm.

The **Day Night Switch Alarm** page is displayed, as shown in Figure 6-4.

Figure 6-4 Day night switch alarm

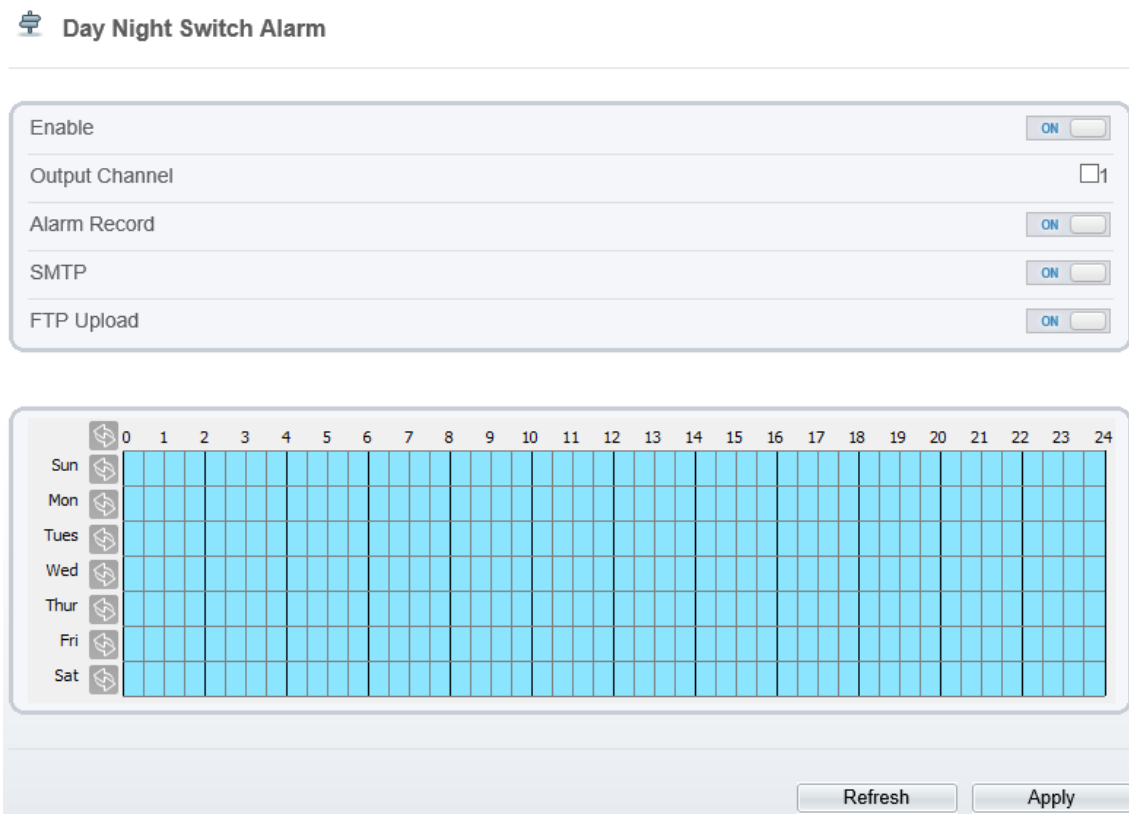

- Step 2 Click the button to enable day night switch alarm.
- Step 3 Configure the day night switch alarm schedule.

**Method 1:** Click left mouse button to select any time point within 0:00-24:00 from Monday to Sunday as shown in Figure 6-7.

**Method 2:** Hold down the left mouse button, drag and release mouse to select the schedule within 0:00-24:00 from Monday to Sunday.

 **NOTE**

When you select time by dragging the cursor, the cursor cannot be moved out of the time area. Otherwise, no time can be selected.

**Method 3:** Click  in the schedule page to select the whole day or whole week.

**Deleting deployment time:** Click  again or inverse selection to delete the selected schedule.

Figure 6-5 Schedule Setting page



Step 4 Click the button on to enable Alarm Record.

Step 5 Click the button on to enable SMTP.

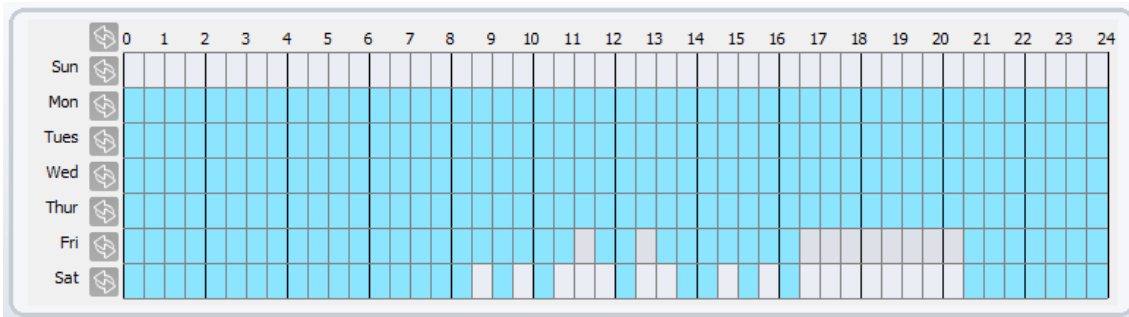
Step 6 Click the button on to enable FTP Upload.

Step 7 Click **Apply**.

The message "Apply success!" is displayed, the system saves the settings

## 6.5 I/O Alarm Linkage (Only for Some Models)

### Description

Alarm linkage refers to linkage alarm output. When receiving an alarm from the alarm input port, the camera performs linkage alarm output, and operate based on the linkage policy.

On the **I/O Alarm Linkage** page, you can perform the following operations:

- Enable the I/O alarm function.
- Configure the I/O alarm schedule.
- Configure the alarm output channel.

## Procedure

Step 1 Choose Configuration > Alarm > I/O Alarm Linkage.

The **I/O Alarm Linkage** page is displayed, as shown in Figure 6-6.

Figure 6-6 I/O Alarm Linkage page

**I/O Alarm Linkage**

Alarm Input: 1

Name:

Trigger Mode: Connect

Alarm Input:  OFF

Output Channel:  1

Alarm Record:  OFF

SMTP:  OFF

FTP Upload:  OFF

	0	1	2	3	4	5	6	7	8	9	10	11	12	13	14	15	16	17	18	19	20	21	22	23	24
Sun																									
Mon																									
Tues																									
Wed																									
Thur																									
Fri																									
Sat																									

Refresh Apply

Step 2 Select the **Alarm Input** value from the drop-down list box.

Step 3 Enter alarm input channel name.

Step 4 Select the **Trigger Mode** from the drop-down list box.

Step 5 Click the button on to enable I/O Alarm.

Step 6 Configure the I/O alarm schedule.

**Method 1:** Click left mouse button to select any time point within 0:00-24:00 from Monday to Sunday as shown in Figure 6-7.

**Method 2:** Hold down the left mouse button, drag and release mouse to select the schedule within 0:00-24:00 from Monday to Sunday.

### NOTE

When you select time by dragging the cursor, the cursor cannot be moved out of the time area. Otherwise, no time can be selected.

**Method 3:** Click in the schedule page to select the whole day or whole week.

**Deleting deployment time:** Click  again or inverse selection to delete the selected schedule.

Figure 6-7 Schedule Setting page



Step 7 Select the **Out Channel** from the drop-down list box.

Step 8 Select the **PTZ Type** from the drop-down list box. The PTZ type includes preset, scan, track, tour.

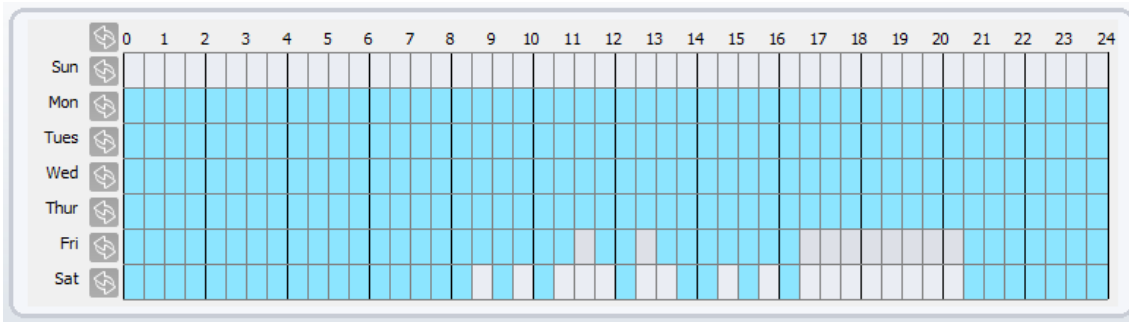
Step 9 Select **Value**. The value is the ID of PTZ type.

Step 10 Click the button on to enable Alarm Record.

Step 11 Click the button on to enable SMTP.

Step 12 Click the button on to enable FTP Upload.

Step 13 Click **Apply**.

The message "Apply succeed!" is displayed, and the system saves the settings.

## 6.6 Motion Detection Alarm Linkage

### Description

On the **Motion Alarm** page, you can perform the following operations:

- Enable the motion detection function.
- Set the motion detection alarming time.
- Set the motion detection area.
- Configure the motion alarm output channel.

When the alarm output function is enabled and the camera detects that an object moves into the motion detection area within the schedule time, the camera generates an alarm and triggers linkage alarm output.

- Configure the PTZ linkage policy

## Procedure

Step 1 Choose Configuration >Alarm > Motion Alarm.

The **Motion Alarm** page is displayed, as shown in Figure 6-8.

Figure 6-8 Motion Alarm page

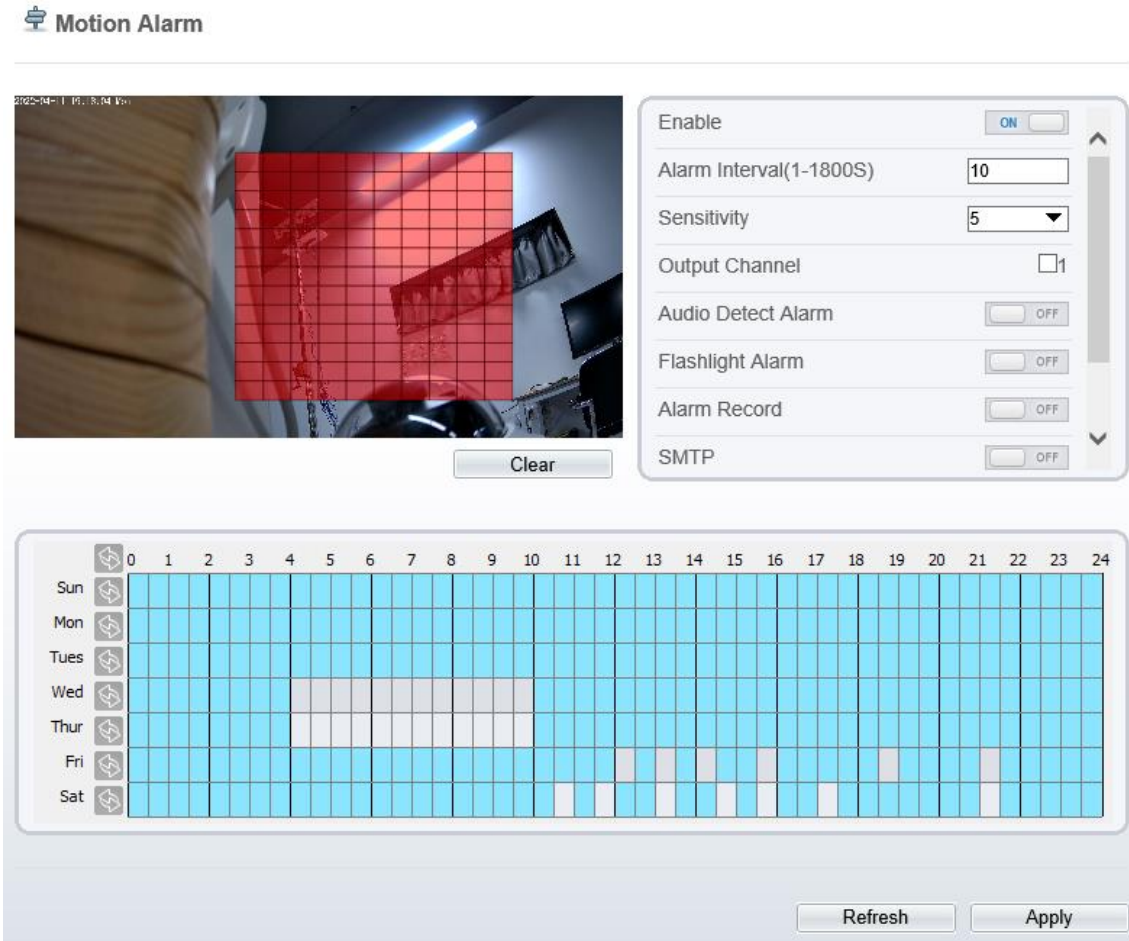

Step 2 Click the button on to enable motion alarm.

Step 3 Configure the motion interval.

Step 4 Configure the sensitivity. Tick the output channel when the camera is connected to the external alarm device.

Step 5 Enable audio detect alarm, flashlight alarm, alarm record. (sound detection alarm is only applicable for some models)

Step 6 Configure the schedule time setting.

For more details about how to set **Schedule**, see 6.5 Step 6.

Step 7 Configure the detection area.

1. Press and hold the left mouse button, and drag in the video area to draw a detection area, as shown in Figure 6-9.

Figure 6-9 Motion Area Setting page

## Motion Alarm

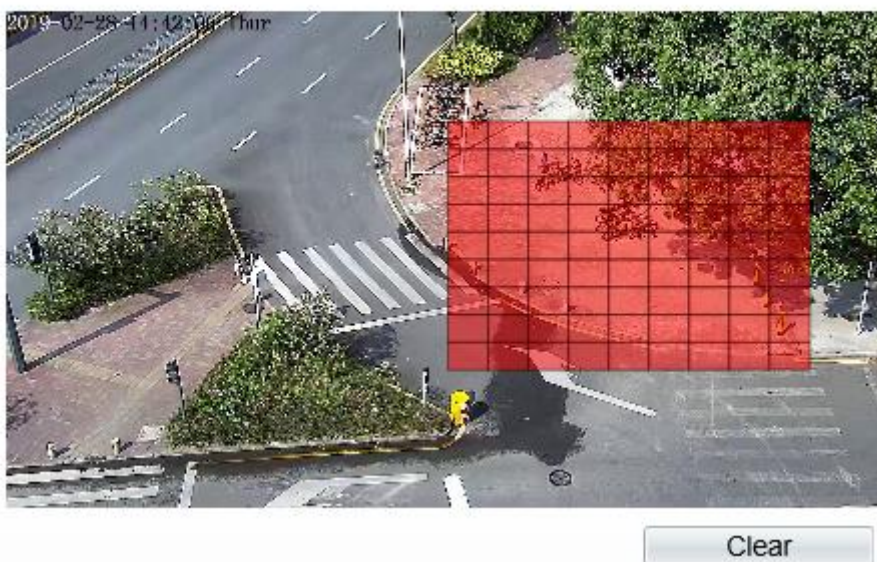

2. Press and hold the left mouse button, and drag in the video area to draw a detection area.

### NOTE

- Click **Clear** to delete a detection area.
- Click **Reverse** to select the area out of specified frames as the detection area.

Step 8 Select the **Out Channel**.

Step 9 Click the button on to enable alarm record.

Step 10 Click the button on to enable audio detect alarm / flashlight alarm (supplied for some models)

Step 11 Click the button on to enable SMTP.

Step 12 Click the button on to enable FTP Upload.

Step 13 Select the **PTZ Type** from the drop-down list box. The PTZ type includes preset, scan, track, tour.

Step 14 Select **Value**. The value is the ID of PTZ type.

Step 15 Click **Apply**.

The message "Apply succeed!" is displayed, and the system saves the settings.

## 6.7 Push Message

### Description

When enable push message button, the alarm information will be pushed to app if the device is managed by app.

### Procedure

Step 1 Choose Configuration > Alarm > Push Message.

The **Push Message** page is displayed, as shown in Figure 6-10.

Figure 6-10 Push Message page

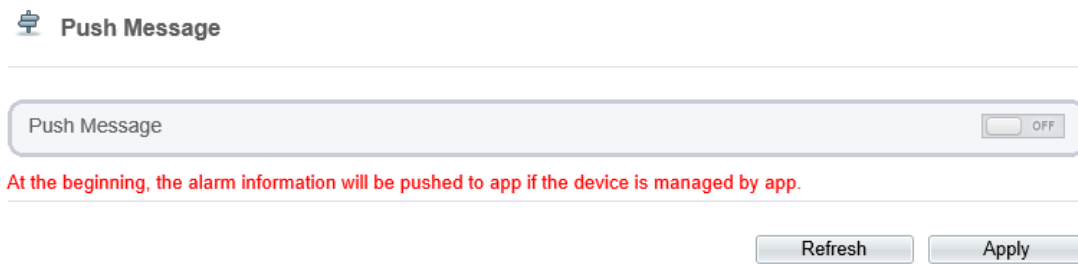

Step 2 Click **Apply**.

The message "Apply succeed!" is displayed, and the system saves the settings.

## 6.8 Audio Abnormal Detection (Only for Some Models)

### Description

On the **Audio Abnormal Detection** page, you can perform the following operations:

- Enable the Audio Abnormal Detection function.
- Set the Audio Abnormal Detection alarming time.
- Configure the Audio Abnormal Detection output channel.

When the alarm output function is enabled and the camera detects abnormal audio (sudden rise or sudden drop) within the schedule time, the camera generates an alarm and triggers linkage alarm output.

### Procedure

Step 1 Choose Configuration > Alarm > Audio Abnormal Detection.

The **Audio Abnormal Detection** page is displayed, as shown in Figure 6-11.

Figure 6-11 Audio abnormal detection

**Audio Abnormal Detection**

Enable	<input type="checkbox"/>	OFF
Sudden Rise	<input type="checkbox"/>	OFF
Sudden Drop	<input type="checkbox"/>	OFF
Output Channel	<input type="checkbox"/>	1
Alarm Record	<input type="checkbox"/>	OFF
SMTP	<input type="checkbox"/>	OFF
FTP Upload	<input type="checkbox"/>	OFF

Real Time Volume



	<input type="checkbox"/>	0	1	2	3	4	5	6	7	8	9	10	11	12	13	14	15	16	17	18	19	20	21	22	23	24
Sun	<input type="checkbox"/>																									
Mon	<input type="checkbox"/>																									
Tues	<input type="checkbox"/>																									
Wed	<input type="checkbox"/>																									
Thur	<input type="checkbox"/>																									
Fri	<input type="checkbox"/>																									
Sat	<input type="checkbox"/>																									

Refresh Apply

- Step 2 Click the button on to enable audio abnormal detection.
- Step 3 Enable Sudden Rise, and Sudden Drop.
- Step 4 Select the **Out Channel**.
- Step 5 Select **Value**. The value is the ID of PTZ type (Only for Some Models).
- Step 6 Click the button on to enable Alarm Record.
- Step 7 Click the button on to enable SMTP.
- Step 8 Click the button on to enable FTP Upload.
- Step 9 Configure the schedule time setting.
  - For details about how to set **Schedule**, see 6.5 Step 6.

## 6.9 Sound Alarm Output (Only for Some Models)

At **Configuration > Alarm > Sound Alarm Output** interface, set the audio detect alarm, as shown in Figure 6-12.

Figure 6-12 Audio alarm interface

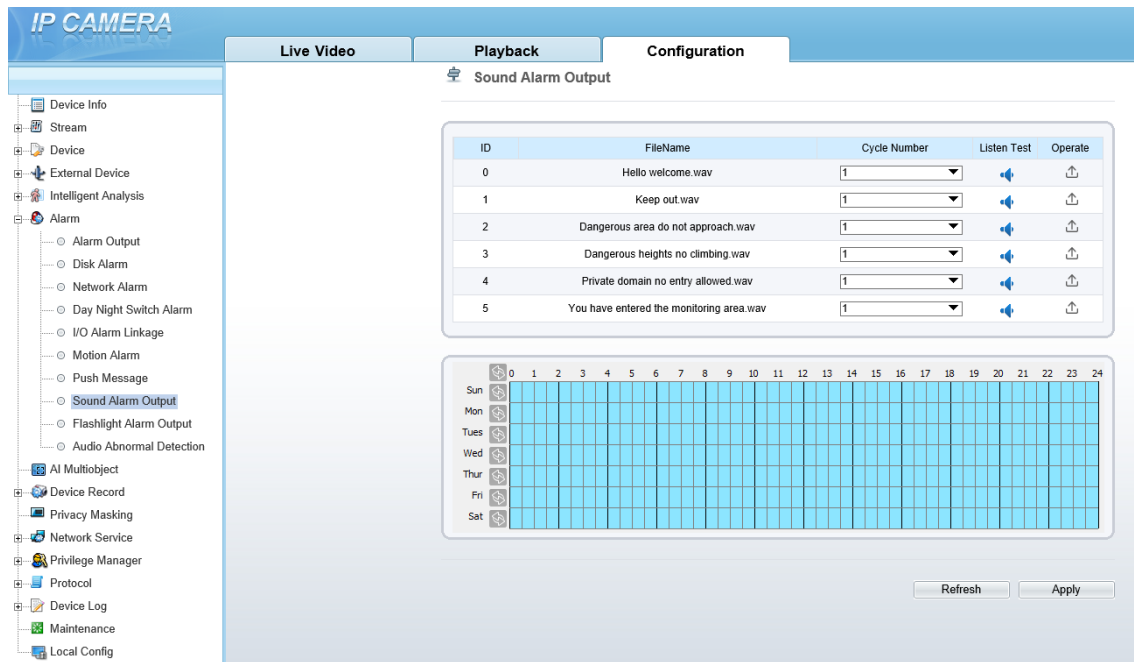

There are six default files, user can set the cycle number, click to test listen.

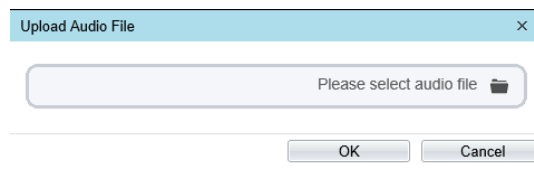

Click to upload a new audio.

The file should be less than 300 kb, and the type is wav.

Click “Apply” to save the settings.

## 6.10 Flashlight Alarm Output (Only for Some Models)

At **Configuration > Alarm > Flashlight Alarm Output** interface, set the schedule to enable flashlight alarm, as shown in Figure 6-13.

Figure 6-13 Flashlight alarm interface

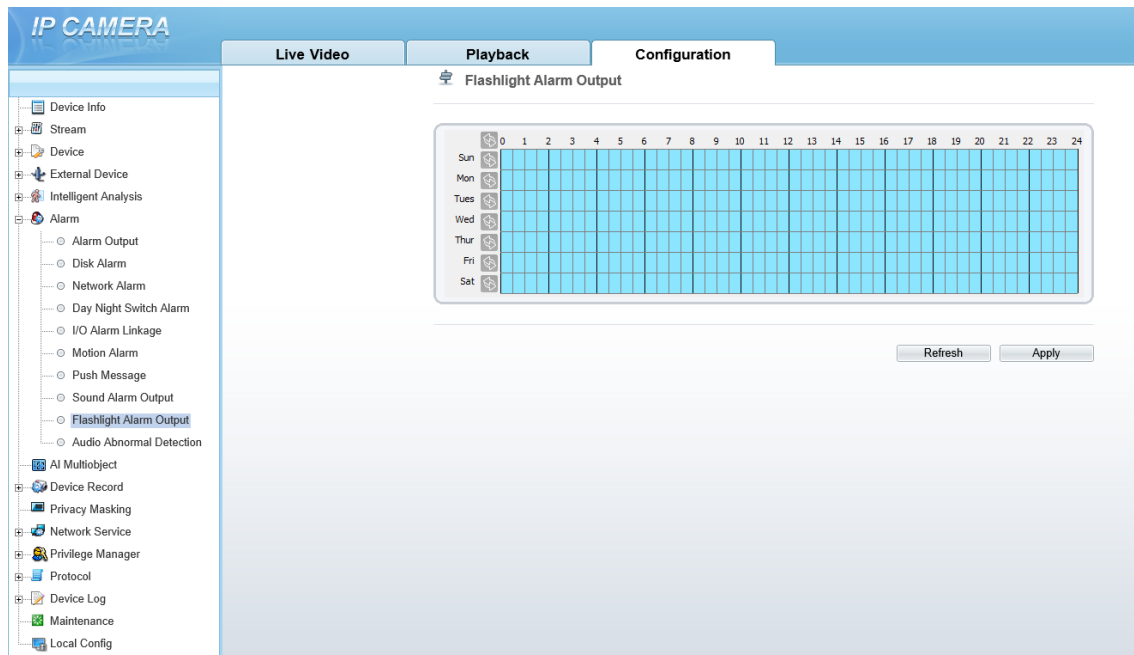

The mouse to drag choose the time, or click one by one to choose.

Click  to choose one day or whole week. Click again to quit the choose.

Click “Apply” to save the settings.

# 7 AI Multiobject

## 7.1 AI Configuration

Choose **Configuration** > **AI Multiobject** to set parameter of detected face, and vehicle plate.

Figure 7-1 AI Multiobject interface

**AI Multiobject**

Face Detection  OFF

Fullbody Detection  ON

Vehicle Detection  OFF

Display Trace Info Mode1

Show Detection Area  OFF

Confidence Coefficient Mid

Body Pixel Min(30-300) 50

Image Matting Quality Highest

Clear

	0	1	2	3	4	5	6	7	8	9	10	11	12	13	14	15	16	17	18	19	20	21	22	23	24
Sun																									
Mon																									
Tues																									
Wed																									
Thur																									
Fri																									
Sat																									

Refresh Apply

Body Pixel Min(30-300) 50

Vehicle Pixel Min(30-800) 50

Image Matting Quality Highest

Snapshot Mode Timing

Upload Image Interval(1-10s) 5



FTP Upload Image Matting  OFF

FTP Upload Whole Image  OFF

Algorithms Library Version v1.0.0\_20220107

Table 7-1 lists the AI multiobject parameters.

**Table 7-1** AI multiobject parameters

Parameter	Description	How to set
Face detection	The camera will snap the face when someone appears in live video.	Enable
Full body detection	The camera will snap the whole body when someone appears in live video.	Enable
Vehicle detection	The camera will snap the vehicle when the vehicle appears in live video.	Enable
Display trace info	Enable the function and a trace frame will show at live video.  Mode 1:  Mode 2:	Choose from drop list.
Confidence coefficient	The range of snap image, there are three types, such as high, mid and low. The higher the confidence, the better the snap quality and the fewer snapshots.	Choose from drop list.
Face pixel min(30-300)	30-300 pixels, the smaller the pixel be set, the more face will be captured, but it may be mistaken.	Input a value ranges 30 to 300
Body pixel min(30-300)	30-300 pixels, the smaller the pixel be set, the more body will be captured, but it may be mistaken.	Input a value range 30 to 300
Vehicle pixel min(30-300)	30-300 pixels, the smaller the pixel be set, the more face will be captured, but it may be mistaken.	Input a value ranges 30 to 300
Image matting quality	The quality of snap image, There are three mode can be chosen, such as low, mid and high.	Choose from drop list.
Snapshot mode	There are three mode can be chosen, such as timing, and optimal.	Choose from drop list.
Upload image interval(1-10 s)	At timing mode, set the interval of upload image.	Input a value ranges 1 to 10
Snapshot count	At optimal mode, set the number of snapshot image	Input a value ranges 1 to 5
FTP upload image matting	<b>Configuration &gt; Network Service &gt; FTP</b> , set FTP related parameters, the captured picture will be sent to the set FTP location	Enable
FTP upload whole image	Capture a picture and send a whole image.	Enable

# 8 Configure the Recording Function

## NOTE

Some models may not support SD card, and the recording function is disabled, please refer to actual product.

## 8.1 Record Policy

You can configure the scheduled recording function, alarm recording function, recording quality, and recording rules.

### Procedure

Step 1 Choose Configuration > Device Record > Record Policy.

The **Record Policy** page is displayed, as shown in Figure 8-1.

Figure 8-1 Record policy page

**Record Policy**

Schedule Record  OFF

Post Record(0-86400s) \*10

Record Audio  OFF

Record Rule Cycle Store

Stream Name stream1

Calendar grid showing days (Sun-Sat) and hours (0-24).

Refresh Apply

Step 2 Set the parameters according to Table 8-1.

Table 8-1 Recording policy parameters

Parameter	Description	Setting
Schedule Record	Enables schedule record that you can configure the time policy.	[Setting method] Click the button on to enable schedule record. [Default value] OFF

Parameter	Description	Setting
Post Record (0-86400s)	Recording duration (in seconds) after an alarm is generated.	[Setting method] Enter a value manually.
Record Audio	Indicates whether to record audios together with videos.	[Setting method] Click the button on to enable record audio.
Record Rule	<p>Rule for saving recordings. The options are as follows:</p> <ul style="list-style-type: none"> <li>• <b>Cycle Store:</b> Saves recordings in cycles.</li> <li>• <b>Save Days:</b> Duration (in days) for saving a recording. The duration can be a maximum of 99999 days.</li> </ul> <p>NOTE The value <b>0</b> indicates that recordings are not overwritten.</p>	[Setting method] Select a value from the drop-down list box.
Stream Name	Name of the stream.	[Setting method] Select a value from the drop-down list box.

Step 3 Configure a recording plan.

You can configure the system to record videos around the clock or in schedule.

For details about how to set **Schedule**, see 6.5 Step 6.

Step 4 Click Apply.

- If the message "Apply success!" is displayed, the system saves the settings.
- If other information is displayed, set the parameters correctly.

-

## 8.2 Record Directory

### Description

Recordings can be stored in an SD card.

### Procedure

Step 1 Choose Configuration > Device Record > Record Directory.

The **Record Directory** page is displayed, as shown in Figure 8-2.

Figure 8-2 Record Directory page

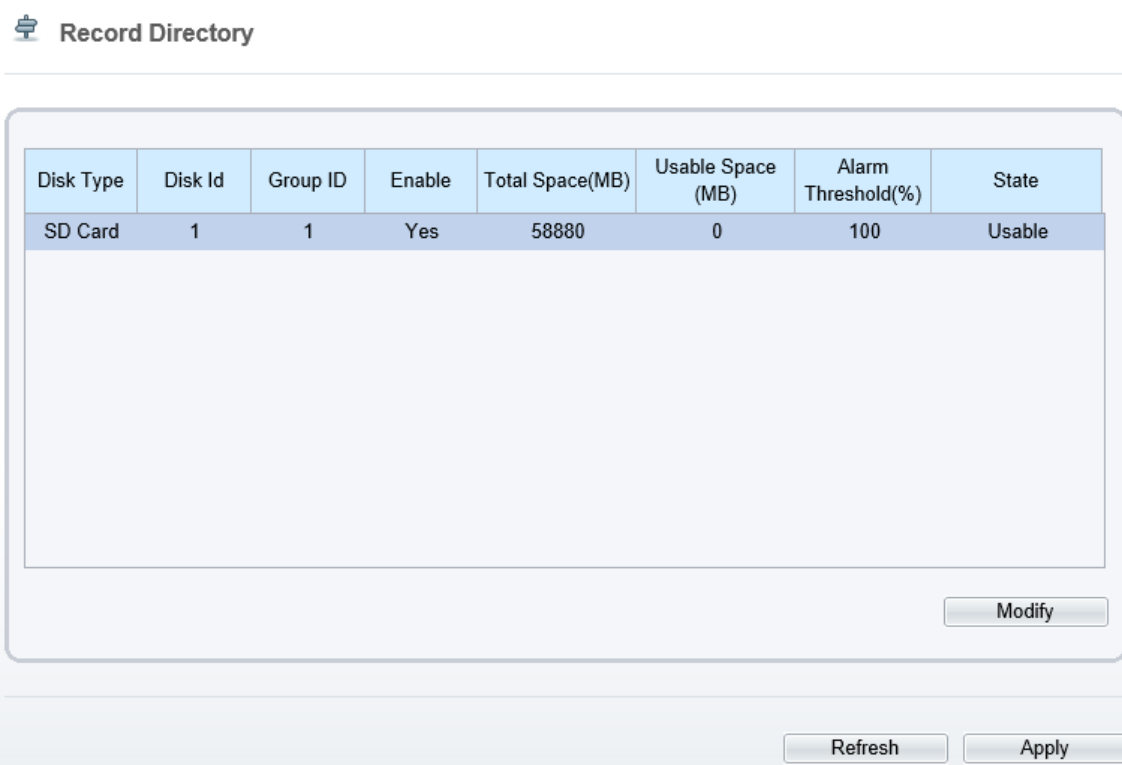

Step 2 Set the parameters according to Table 8-2.

**Table 8-2** Record directory parameters

Parameter	Description	Setting
Disk Type	Recording directory type, which can be an SD card.	[Setting method] The parameter cannot be set manually.
Disk ID	Indicates the Disk ID.	
Group ID	Indicates the group HID.	
Enable	Indicates whether to enable the recording directory.	
Total Space	Total disk space.	
Usable Space	Maximum disk space read automatically.	
Alarm Threshold (%)	The camera will alarm when used Space achieves the alarm threshold.	
Status	Status of the connection between the current camera and recording directory detected automatically.	

Step 3 Click **Modify** to modify the parameters of recording path.

Figure 8-3 Record path modify

Record Path Modify

SD Card	ON
Disk Id	1
Total Space(MB)	0
Alarm Threshold(1-100)	100

Modify

Format

## 8.2.1 Configure the SD Card

### Procedure

- Step 1 Choose Configuration > Device Record > Record Directory.
- Step 2 Click **Modify**.

The **Record Path Modify** page is displayed, as shown in Figure 8-4.

Figure 8-4 SD card Record Path Modify page

Record Path Modify

SD Card	ON
Disk Id	1
Total Space(MB)	58880
Alarm Threshold(1-100)	100

Modify

Format

Step 3 Set the parameters according to Table 8-3.

**Table 8-3** SD card recording parameters

<b>Parameter</b>	<b>Description</b>	<b>Setting</b>
SD Card	Enable SD card to enable record.	[Setting method] Click button to enable SD card.
Disk ID	ID of SD card.	N/A
Total Space(MB)	Total disk space read automatically.	[Setting method] The parameter cannot be set manually.
Alarm Threshold (1-100)	The camera will alarm when used Space achieves the alarm threshold.	[Setting method] Enter a value from 1-100.

Step 4 Click **Apply**.

The message "Apply success!" is displayed, and the system saves the settings.

-

# 9 Configure the Privacy Mask Function

## Procedure

Step 1 Choose Configuration > Privacy Masking.

The **Privacy Masking** page is displayed, as shown in Figure 9-1.

Figure 9-1 Privacy Masking page

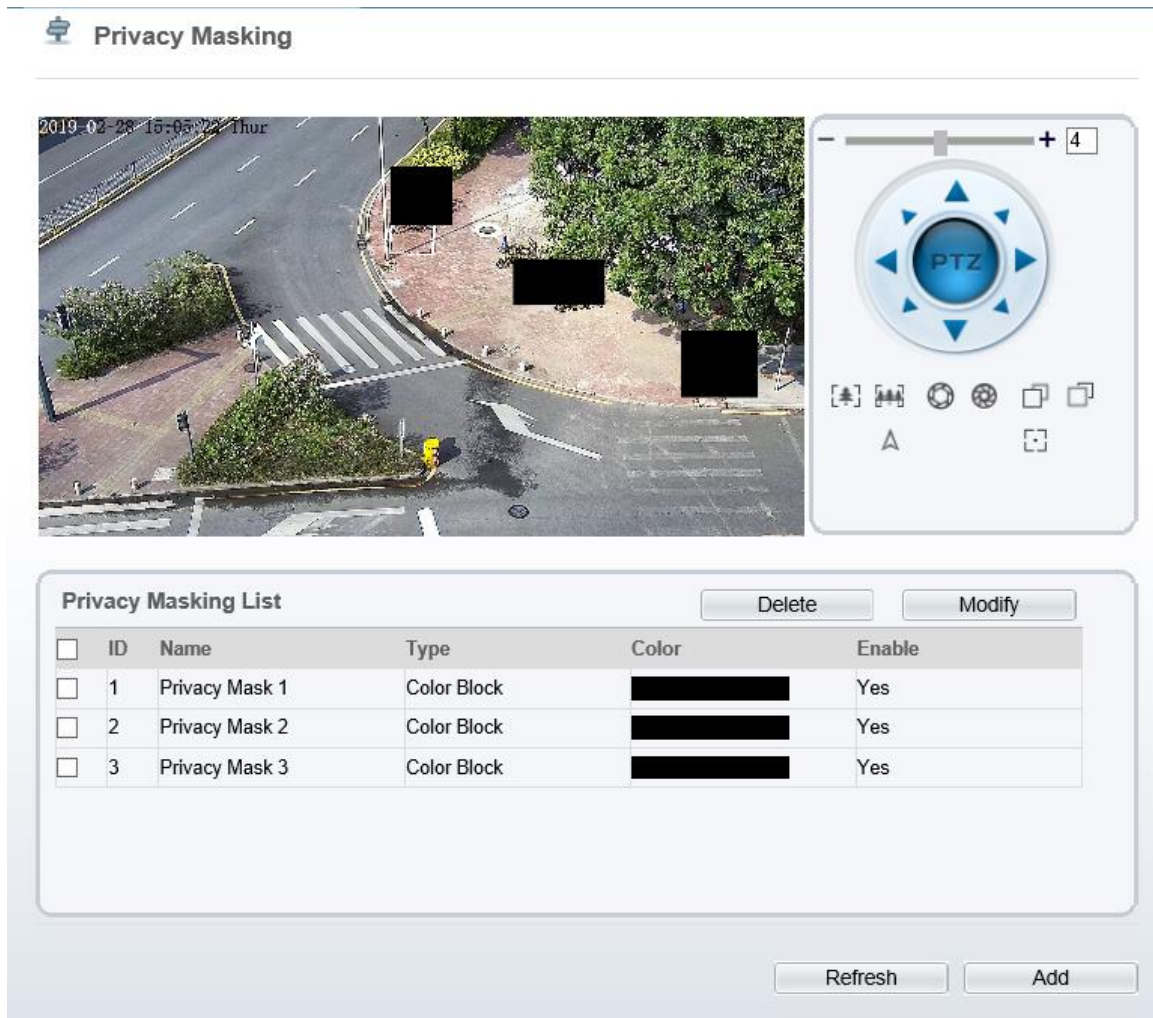

Step 2 Press and hold the left mouse button, and drag on the preview image to cover the part to be masked.

### NOTE

- The maximum percentage of an image that can be masked depends on the device model. Read the tip displayed on the page.
- A maximum of four areas can be masked.
- Tick the ID of mask area and click Delete to delete the area. .

Step 3 Set the parameters according to Table 9-1.

**Table 9-1** Privacy Masking parameters

Parameter	Description	Setting
ID	ID of Privacy Masking.	N/A
Name	Name of privacy Masking.	[Setting method] Click the name and enter a value manually. [Default value] Blank
Type	Type of privacy masking.	[Setting method] Select a value from the drop-down list box. [Default value] Color Block
Color	Color of privacy masking.	[Setting method] Select a value from the drop-down list box. [Default value] Black
Enable	Indicates whether to enable the privacy masking.	[Setting method] Select a value from the drop-down list box. [Default value] Yes
Delete	Delete a privacy masking.	[Setting method] 1. Select a privacy masking from the Privacy Masking List. 2. Click <b>Delete</b> , the privacy masking is deleted successfully
Modify	Modify a privacy masking.	[Setting method] 3. Select a privacy masking from the Privacy Masking List. 4. Click a parameter and modify it. 5. Click <b>Modify</b> , the privacy masking is modified successfully

Step 4 Click **Apply**.

The message "Apply success!" is displayed, and the system saves the settings.

# 10 Configure the Network Service

## 10.1 802.1x

### Preparation

802.1x authentication must be configured on the access port, which controls to access network resources for the connected user devices on the port.

### Procedure

Step 1 Choose Configuration > Network Service > 802.1x.

The **802.1x** page is displayed, as shown in Figure 10-1.

Figure 10-1 **802.1x** page

802.1x ON

Account

Password

ConfirmPassword

Refresh Apply

Step 2 Click the button on to enable **802.1x**.

Step 3 Enter the account name.

Step 4 Enter the password and confirm password..

Step 5 Click **Apply**.

The message "Apply success!" is displayed, and the system saves the settings.

## 10.2 DDNS

### Preparation

Connect the specified camera to the Internet, and obtain the user name and password for logging into the Dynamic Domain Name System (DDNS) server.

### Procedure

Step 1 Choose Configuration > Network Service > DDNS.

The **DDNS** page is displayed, as shown in Figure 10-2.

Figure 10-2 DDNS page

Step 2 Click the button on to enable **DDNS**.

Step 3 Set the parameters according to Table 10-1.

**Table 10-1** DDNS parameters

Parameter	Description	Setting
DDNS	Indicates whether to enable the DDNS service.	[Setting method] Click the button on to enable DDNS. [Default value] OFF
Provider	DDNS service provider. Currently, only 3322 and dyndns are supported.	[Setting method] Select a value from the drop-down list box. [Default value] 3322 NOTE Set this parameter based on the site requirements.
Network Card Name	Name of network card	[Setting method] Select a value from the drop-down list box. [Default value] Eth0
Host Name	Host name is customized by a user.	[Setting method] Enter a value manually. [Default value] Blank

Parameter	Description	Setting
Accounts	User name for logging in to the DDNS server.	[Setting method] Enter a value manually. [Default value] Blank
Password	Password for logging in to the DDNS server.	[Setting method] Enter a value manually. [Default value] Blank

Step 4 Click **Apply**.

- If the message "Apply success!" is displayed, and the system saves the settings.
- If other information is displayed, set the parameters correctly.

## 10.3 PPPoE

### Preparation

Obtain the PPPoE user name and password from the network carrier.

### Description

If a PPPoE connection is used, you need to enter the user name and password on the **PPPoE** page. After you restart the device, the PPPoE settings take effect and the device obtains a public IP address.

### Procedure

Step 1 Choose Configuration > Network Service > PPPoE.

The **PPPoE** page is displayed, as shown in Figure 10-3.

Figure 10-3 PPPoE page

The screenshot shows the PPPoE configuration interface. At the top left is a router icon and the text 'PPPoE'. Below this is a rounded rectangular box containing the following elements: a 'PPPoE' label with an 'ON' toggle switch to its right; an 'Account' label followed by an empty text input field; a 'Password' label followed by an empty text input field. Below this box is another rounded rectangular box with the label 'IP Address' and the value 'Empty'. At the bottom right of the page are two buttons: 'Refresh' and 'Apply'.

Step 2 Click the button on to enable **PPPoE**.

Step 3 Set the parameters according to Table 10-2.

**Table 10-2** PPPoE parameters

Parameter	Description	Setting
PPPoE	Click to enable PPPoE dialing.	[Setting method] Click the button on. [Default value] OFF
Accounts	User name of PPPoE provided by the network carrier.	[Setting method] Enter a value manually.
Password	Password of PPPoE provided by the network carrier.	[Setting method] Enter a value manually.

Step 4 Click **Apply**.

- If the message "Apply success!" is displayed, and the system saves the settings.
- If other information is displayed, set the parameters correctly.

## 10.4 Port Mapping

### Description

Port mapping helps establish a mapping relationship between the private network and the external network. Port mapping allows outside computers to access intranet devices so that the network works efficiently.

### Procedure

Step 1 Choose **Configuration > Network Service > Port Mapping**.

The **Port Mapping** page is displayed, as shown in Figure 10-4.

Figure 10-4 Port Mapping page

Port Mapping ON

Map Mode Auto ▼

Auto Port Mapping

Enable	PortType	OutsidePort	OutsideIP Address	State
<input checked="" type="checkbox"/>	SSLCONTROL	20001	0.0.0.0	Ineffective
<input checked="" type="checkbox"/>	HTTP	80	0.0.0.0	Ineffective
<input checked="" type="checkbox"/>	RTSP	554	0.0.0.0	Ineffective
<input checked="" type="checkbox"/>	CONTROL	30001	0.0.0.0	Ineffective
<input checked="" type="checkbox"/>	HTTPS	443	0.0.0.0	Ineffective

Refresh Apply

Step 2 Click the button on to enable **Port Mapping**.

Step 3 Set the parameters according to Table 10-3.

**Table 10-3** Port mapping parameters

Parameter	Description	Setting
Port Mapping	Indicates whether to enable the Port Mapping service.	[Setting method] Click the button on. [Default value] OFF
Map Mode	Mode of port mapping, includes auto and manual.	[[Setting method] Select a value from the drop-down list box. [Default value] Auto
Port Type	Port Type includes: SSLCONTROL HTTP, RTSP, Control and HTTPS.	N/A
Outside Port	Port of outside network.	[Setting method] Enter a value manually in map mode.
Outside IP Address	IP address of outside network.	N/A
State	Mapping status	N/A

Step 4 Click **Apply**.

- If the message "Apply success!" is displayed, and the system saves the settings.
- If other information is displayed, set the parameters correctly.

## 10.5 SMTP

### Description

If the Simple Mail Transfer Protocol (SMTP) function is enabled, the device automatically sends JPG images and alarm information to specified email addresses when an alarm is generated.

### Procedure

Step 1 Choose Configuration > Network Service > SMTP.

The **SMTP** page is displayed, as shown in Figure 10-5.

Figure 10-5 SMTP page

Step 2 Set the parameters according to Table 10-4.

#### NOTE

Parameters marked with are mandatory.

**Table 10-4** SMTP parameters

Parameter	Description	Setting
SMTP Server Address	IP address of the SMTP server.	[Setting method] Enter a value manually.

Parameter	Description	Setting
SMTP Server Port	Port number of the SMTP server.	[Setting method] Enter a value manually. [Default value] 25
User Name	User name of the mailbox for sending emails.	[Setting method] Enter a value manually.
Password	Password of the mailbox for sending emails.	[Setting method] Enter a value manually.
Sender E-mail Address	Mailbox for sending emails.	[Setting method] Enter a value manually.
Recipient_E-mail_Address 1	(Mandatory) Email address of recipient 1.	[Setting method] Enter a value manually.
Recipient_E-mail_Address 2	(Optional) Email address of recipient 2.	
Recipient_E-mail_Address3	(Optional) Email address of recipient 3.	
Recipient_E-mail_Address 4	(Optional) Email address of recipient 4.	
Recipient_E-mail_Address 5	(Optional) Email address of recipient 5.	
Attachment Image Quality	A higher-quality image means more storage space. Set this parameter based on the site requirement.	N/A
Transport Mode	Email encryption mode. Set this parameter based on the encryption modes supported by the SMTP server.	[Setting method] Select a value from the drop-down list box. [Default value] No Encrypted

Step 3 Click **Apply**.

- If the message "Apply success!" is displayed, and the system saves the settings.
- If other information is displayed, set the parameters correctly.

## 10.6 FTP

### Description

If the File Transfer Protocol (FTP) button is enabled, the device automatically sends the snapped alarm JPG images to specified FTP server.

## Procedure

Step 1 Choose Configuration > Network Service > FTP.

The **FTP** page is displayed, as shown in Figure 10-6.

Figure 10-6 FTP page

Step 2 Click the button on to enable **FTP**.

Step 3 Set the parameters according to Table 10-5.

Table 10-5 FTP parameters

Parameter	Description	Setting
FTP Upload	Indicates whether to enable the FTP service.	[Setting method] Click the button on. [Default value] OFF
FTP Address	IP address of FTP server.	[Setting method] Enter a value manually.
FTP Port	Port of FTP server.	[Setting method] N/A [Default value] 21
Account	FTP server account.	[Setting method] Enter a value manually.
Password	FTP server Password.	[Setting method] Enter a value manually.
FTP Path	FTP Path to save the JPG image.	[Setting method] Enter a value manually.

Parameter	Description	Setting
Media type	The media type of sending to FTP, snapshot or video clip.	[Setting method] Select a value from the drop-down list box. [Default value] Snapshot

Step 4 Click **Apply**.

- If the message "Apply success!" is displayed, and the system saves the settings.
- If other information is displayed, set the parameters correctly.

## 10.7 IP Filter

### Description

Set the IP address in specified network segment to allow access or prohibit access.

### Procedure

Step 1 Choose Configuration > Network Service > IP Filter.

The **IP Filter** page is displayed, as shown in Figure 10-7.

Figure 10-7 IP Filter page

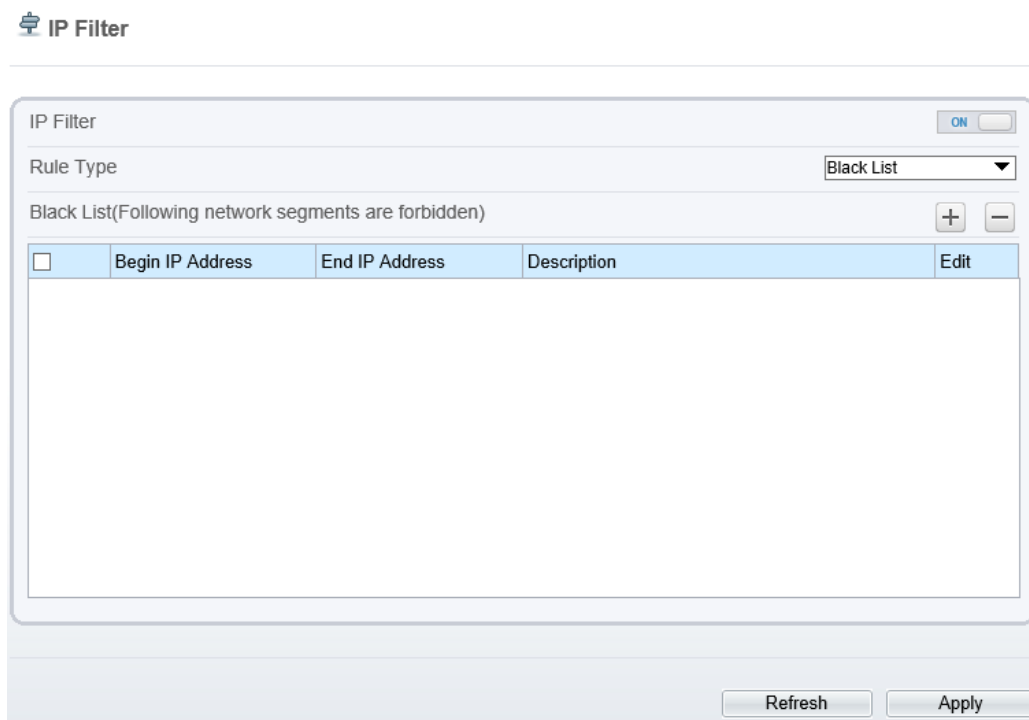

Step 2 Click the button on to enable **IP Filter**.

Step 3 Set the parameters according to Table 10-6

**Table 10-6** IP Filter parameters



Parameter	Description	Setting
IP Filter	Indicates whether to enable the IP Filter.	[Setting method] Click the button on. [Default value] OFF
Rule Type	IP filter type, includes black list and white list.	[Setting method] Select a value from the drop-down list box. [Default value] Black List
Black List	Specified network segment should be excluded.	[Setting method] 6. Click  to enter the add black/white list page, as shown in Figure 10-8 7. Enter Begin IP Address. 8. Enter End IP Address. 9. Enter Description. 10. Click OK, the black list added successfully.
White List	Allow specified network segment to access.	[Setting method] 1. Click  to enter the add black/white list page, as shown in Figure 10-8 2. Enter Begin IP Address. 3. Enter End IP Address. 4. Enter Description. 5. Click OK, add the white list successfully.

Figure 10-8 Add IP Filter page



The screenshot shows a dialog box titled "New" with a close button (X) in the top right corner. The dialog contains three input fields: "Begin IP Address", "End IP Address", and "Description". Below the input fields, there are two buttons: "OK" and "Cancel".

 **NOTE**

Click  to modify the parameters of setting black list or white.

Click  to delete the setting black list or white.

Step 4 Click **Apply**.

The message "Apply success!" is displayed, and the system saves the settings.

## 10.8 CGI Alarm Service Center

### Description

Device will push the alarm message by CGI with Start URL and End URL, and send to data to CGI Server by HTTP protocol. CGI alarm message is the head of User-Agent of HTTP. Use HTTP protocol get and send to CGI Server. When need to integrate the CGI alarm message, need to resolve the HTTP Head "User-Agent" to get the data of CGI alarm message.

### Procedure

Step 1 Choose **Configuration > Network Service > CGI Alarm Service Center**.

The **CGI Alarm Service Center** page is displayed, as shown in Figure 10-9.

Figure 10-9 CGI Alarm Service Center page

 **CGI Alarm Service Center**

---

CGIAlarm ON

Alarm Type All ▼

Name

Type HTTP ▼

URL Start

URL End

Proxy Setting ON

Address

Port

Platform User Name

Platform Password

Test the connection to the specifield HTTP server

Step 2 Click the button on to enable **CGI Alarm**.

Step 3 Set the parameters according to Table 10-7.

**Table 10-7** CGI Alarm Service Center parameters

Parameter	Description	Setting
CGI Alarm	Indicates whether to enable the CGI Alarm.	[Setting method] Click the button on. [Default value] OFF
Alarm Type	All alarm types can be chosen, user can choose one to alarm, or choose all.	[Setting method] Select a value from the drop-down list box. [Default value] All
Name	Name of CGI Alarm.	[Setting method] Enter a value manually.
Type	Type of CGI Alarm.	[Setting method] Select a value from the drop-down list box. [Default value] HTTP
URL Start	Push the alarm message by CGI with start URL	[Setting method] Enter a value manually. For example: http://192.168.35.74:80/MajorAlarmType&MinorAlarmType&SourceName&DeviceID&DeviceIP&AlarmTime&Description
URL End	Push the alarm message by CGI with end URL	[Setting method] Enter a value manually. For example: http://192.168.35.74:80/MajorAlarmType&MinorAlarmType&SourceName&DeviceID&DeviceIP&AlarmTime&Description
User Name	User name of device.	[Setting method] Enter a value manually.
Password	Password of device.	[Setting method] Enter a value manually.
Proxy Setting	Indicates whether to enable the Proxy. Forwarder server of CGI alarm to forward the CGI alarm.	[Setting method] Click the button on. [Default value] OFF
Address	IP address of Forwarder server.	[Setting method] Enter a value manually.
Port	Port of Forwarder server.	[Setting method] Enter a value manually.

Parameter	Description	Setting
Platform User Name	User name of forwarder server.	[Setting method] Enter a value manually.
Platform Password	Password of forwarder server.	[Setting method] Enter a value manually.
Test the connection to the specified HTTP server	Test if the device connects to the proxy successfully.	[Setting method] Click Test, if the device connects to the proxy successfully, the message “Test CGI alarm success” is displayed.

Step 4 Click **Apply**.

The message "Apply success!" is displayed, and the system saves the settings. If the message is “Parameter is invalid”, you should check if the parameters are correct.

## 10.9 SNMP

### Description

Simple Network Management Protocol (SNMP) is an Internet Standard protocol, supports SNMP v1, SNMPv2c and SNMPv3 network protocol. Choose the proper SNMP protocol version and set the SNMP protocol parameter to collect and organize information about managed devices on IP networks.

### Procedure

Step 1 Choose **Configuration > Network Service > SNMP**.

The **SNMP** page is displayed, as shown in Figure 10-10.

Figure 10-10 SNMP page

 **SNMP**

---

SNMPv1 ON

SNMPv2c ON

Write Community

Read Community

Trap Address

Trap Port

Trap Community

SNMPv3 ON

Read Security Name

Security Level

Auth Algorithm

Auth Password

Encry Algorithm

Encry Password

Write Security Name

Security Level

Auth Algorithm

Auth Password

Encry Algorithm

Encry Password

SNMP Port

Step 2 Click the button on to enable **SNMPv1**, **SNMPv2C** and **SNMPv3**.

Set the parameters according to Table 10-8.

**Table 10-8** SNMP parameters

Parameter	Description	Setting
SNMPv1	Version of SNMP.	[Setting method]
SNMPv2c	SNMPv1 and SNMPv2c use communities to establish trust between managers and agents. Agents support three community names, write community, read community and trap.	Click the button on. [Default value] OFF
Write Community	Name of write community. The write community only can modify data.	[Setting method] Enter a value manually.
Read Community	Name of read community. The write community only can read data.	
Trap Address	IP address of the trap.	
Trap Port	Management port of accepting message from trap.	
Trap Community	community string of trap. The trap community string allows the manager to receive asynchronous information from the agent.	
SNMPv3	Version of SNMP. SNMPv3 uses community strings, but allows for secure authentication and communication between SNMP manager and agent.	[Setting method] Click the button on. [Default value] OFF
Read Security Name	Name of read security.	[Setting method] Enter a value manually.
Write Security Name	Name of write security.	
Security Level	Security Level between SNMP manager and agent, includes three levels: No auth: No authentication and no encryption Auth: Authentication but no encryption Priv: Authentication and encryption	[Setting method] Select a value from the drop-down list box. [Default value] Blank
Auth Algorithm	Authentication Algorithm, includes MD5 and SHA.	[Setting method] Select a value from the drop-down list box. [Default value] Blank
Auth Password	Authentication password.	[Setting method] Enter a value manually.

Parameter	Description	Setting
Encrypt Algorithm	Encryption Algorithm, includes DES and AES.	[Setting method] Select a value from the drop-down list box. [Default value] Blank
Encrypt Password	Encryption password.	[Setting method] Enter a value manually.
SNMP Port	Port of SNMP.	[Setting method] Enter a value manually. [Default value] 161

Step 3 Click **Apply**.

The message "Apply success!" is displayed, and the system saves the settings.

## 10.10 QOS

### Description

If the device is connected to a router or switch with a QOS function, and the priority rule of the corresponding mark is configured on the network device, the network device will preferentially pass the data packet of the corresponding mark.

### Procedure

Step 1 Choose **Configuration > Network Service > QOS**.

The **QOS** page is displayed, as shown in Figure 10-11.

Figure 10-11 QOS page

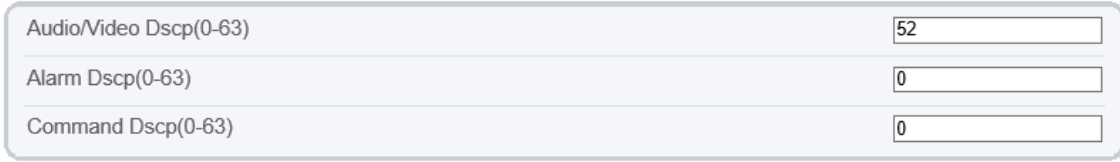

The screenshot shows a configuration table with three rows. The first row is 'Audio/Video Dscp(0-63)' with a value of '52'. The second row is 'Alarm Dscp(0-63)' with a value of '0'. The third row is 'Command Dscp(0-63)' with a value of '0'. Below the table are two buttons: 'Refresh' and 'Apply'.

Audio/Video Dscp(0-63)	52
Alarm Dscp(0-63)	0
Command Dscp(0-63)	0

Refresh Apply

Step 2 Input the value range from 0 to 63( audio/video dscp, alarm dscp and command dscp).

Step 3 Click **Apply**.

The message "Apply success!" is displayed, and the system saves the settings.

## 10.11 Platform Access

### Description

If the device and platform system are not at the same local network, you can connect device and platform system to the external server. You should build a server for platform in advance, platform's remote IP/Port and IP camera are mapping port to external network.

### Procedure

Step 1 Choose **Configuration > Network Service > Platform Access**.

The **Platform Access** page is displayed, as shown in Figure 10-12

Figure 10-12 Platform Access page

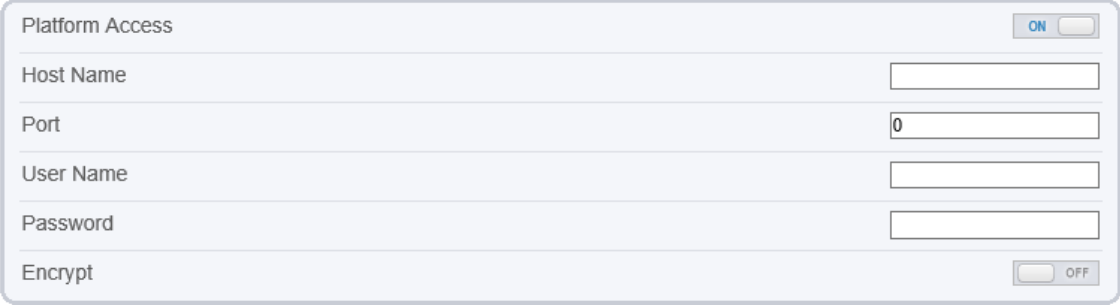

The screenshot shows the 'Platform Access' configuration page. It has a title bar with a lock icon and the text 'Platform Access'. Below the title bar is a toggle switch for 'Platform Access' which is currently 'ON'. There are five input fields: 'Host Name', 'Port' (with '0' entered), 'User Name', and 'Password'. At the bottom left is an 'Encrypt' checkbox which is currently 'OFF'. At the bottom right are two buttons: 'Refresh' and 'Apply'.

Platform Access  ON

Host Name

Port

User Name

Password

Encrypt  OFF

Refresh Apply

Step 2 Input the parameters. The host name and port are same as the platform, as shown in figure. It is the IP or domain of external network server. The user name and password are same as platform login.

Basic Information				Refresh	Back	Restore	Edit	Delete
Server Name :	CMU_127.0.0.1	Type :	CMU	IP:Port :	127.0.0.1 : 10086	Start-up Time :	2022-04-11 15:15:51	
Running State :	Online	Version :	V1.7.1.0.1.0.0_20220331	Remote IP:Port :		Online Time :	4Hrs 15Min 56Sec	
Log Type :	Error	P2P status :	Offline	Device registration port :	17888	SSL port :	15680	
Domain :	Default Domain	P2P UUID :		Remote device registration port :				

Step 3 Add the IPC to platform, you should input the following information

1: IP/ID/Domain name is device ID of IPC.

2: The connection mode should be chosen **Device active registration**.

+ AddDevice
×

Device Name

Device Type IPC

Protocol Private Protocol

IP/ID/ domain name  1

Port 30001

Group Default group

⚙️ Advanced setting

Connection mode Device active registration 2

IAU Not Support

MDU Auto

Save and New
Test
Add
Cancel

#### 🔧 Device Info

Device ID	158888
Device Name	<input type="text"/> ✓
MAC Address	00:1C:27:15:88:88

Step 4 If you want to encrypt the access, you can enable the Encrypt.

Step 5 Click **Apply**.

The message "Apply success!" is displayed, and the system saves the settings.

# 11 Privilege Manager

## 11.1 Configure a User

### Description

You can add, modify, and delete a user in privilege manager page.

### Procedure

Step 1 Choose Configuration > Privilege Manager > User.

The **User** page is displayed, as shown in Figure 11-1. Table 11-1 describes the parameters.

Figure 11-1 User page

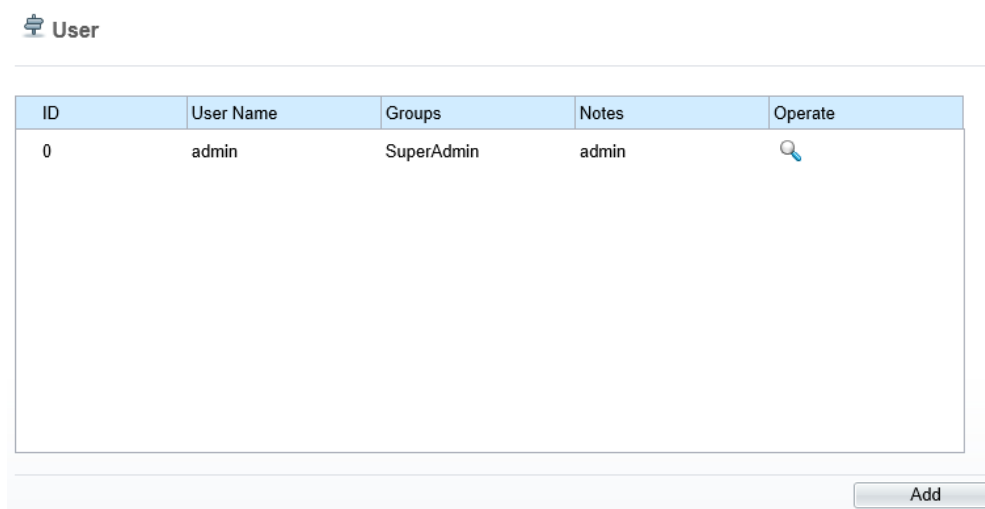

ID	User Name	Groups	Notes	Operate
0	admin	SuperAdmin	admin	

Table 11-1 User parameters

Parameter	Description	Setting
ID	User ID	N/A
User Name	User name for logging in to the camera.	[Setting method] Select a value from the drop-down list box.

Parameter	Description	Setting
Groups	<p>Permission group where a user belongs. The default permission groups are <b>Super Admin</b>, <b>Administrators</b>, <b>Operator</b>, and <b>Media user</b>. Their permissions are described as follows:</p> <ul style="list-style-type: none"> <li>• Super Admin: Includes all privileges.</li> <li>• Administrators: Live Video, Video Control, PTZ control, Audio, Playback, Backup, Record Policy, Disk Configure, Privilege Manage, Parameter Configure, System Maintenance and Log,</li> <li>• Operator: System Maintenance, Parameter Configure, playback, Live Video and Video Control.</li> <li>• Media user: Live Video</li> </ul>	<p>[Setting method] Click <b>Add</b>, then select a value from the drop-down list box.</p>
Notes	Notes of the User.	<p>[Setting method] Click <b>Add</b>, then enter a value manually.</p>
Operate	<p>The operation of the user, includes view user, modify user and delete user.</p> <p>NOTE Super Admin can be viewed only.</p>	<p>[Setting method] Click the icon as required.</p>

Step 2 Add, modify, or delete a user as required.

Table 11-2 are specific operations.

**Table 11-2** Operation description

Function	Procedure	Description
Add	<ol style="list-style-type: none"> <li>1. Click <b>Add</b>. The <b>Add User</b> page is displayed, as shown in Figure 11-2.</li> <li>2. Enter a user name, password, confirm password.</li> <li>3. Select a group from the drop-down list box.</li> <li>4. Enter the notes (Optional).</li> <li>5. Check the privilege.</li> <li>6. Click <b>OK</b>. The user is added successfully.</li> </ol>	<p>Add an administrator or a common user as shown in Figure 11-2.</p>



Function	Procedure	Description
Modify	<ol style="list-style-type: none"> <li>1. Click .</li> </ol> <p>The <b>Modify User</b> page is displayed.</p> <ol style="list-style-type: none"> <li>2. Modify the user name, password, group or privilege.</li> <li>3. Click <b>OK</b>.</li> </ol> <p>The user is modified successfully. The <b>User</b> page is displayed.</p>	Modify the user name, password, group or privilege.
Delete	<p>Select the user from the User list. Click , the message “Confirm to delete?” is displayed, click <b>OK</b>, then the group is deleted successfully.</p>	Delete a user.

Figure 11-2 Add user page

Add User
×

User Name

Password

ConfirmPassword

Group Administrators ▼

Notes

**Privilege**

- Live Video
- Video Control
- PTZ Control
- Audio
- Playback
- Backup
- Record Policy
- Disk Config

**Live VideoPrivilege Detail**

Watching real-time video and switch stream.

 **NOTE**

Click the privilege to view the detailed description of function.

# 12 Configure Protocol Parameters

## 12.1 Protocol Information

### Description

You can view the existing protocol name and version number of the current device on the **Configuration > Protocol > Protocol Info** page, as shown in Figure 12-1. Table 12-1 describes the protocol-related parameters.

Figure 12-1 Protocol Info page

The screenshot shows the 'Protocol Info' page with the following parameters:

Protocol Name	ONVIF
Protocol Version	v17.06
Protocol Software Version	v17.06_build000040
RTSP Rule	rtsp://ip:port/sn/live/cameraid/streamid
RTSP Example	rtsp://192.168.99.14:554/sn/live/1/1
Onvif UUID	014a5ca0-35c9-11e9-9bc

There is a 'Refresh' button at the bottom right of the form.

Table 12-1 Protocol-related parameters

Parameter	Description
Protocol Name	Type of the access protocol.
Protocol Version	Version number of the access protocol.
Protocol Software Version	Software version number of the access protocol.
RTSP Rule	URL rule of Real Time Streaming Protocol.
RTSP Example	URL example of Real Time Streaming Protocol.
Onvif UUID	Universally Unique Identifier.

## 12.2 Security Authentication

### Description

When an ONVIF-compliant device connects to the platform, you must authenticate the user name and password to ensure the connection security.

### Procedure

Step 1 Choose Configuration > Protocol > Security.

The **Security** page is displayed as shown in Figure 12-2. Table 12-2 describes the parameters on the **Security** page.

Figure 12-2 Security page



Table 12-2 Parameter description

Parameter	Description	Setting
User Verification	<p>When you select the <b>User Verification</b> check box, the user name and password must be the same as those for logging in to the device web page.</p> <p>NOTE</p> <p>The default user name is <b>admin</b>, and the default password is <b>admin</b>.</p>	<p>[Setting method]</p> <p>Click the button on to enable <b>User Verification</b>.</p>

Step 2 Click **Apply**.

A dialog box is displayed, indicating the parameter configuration success. To make the configuration take effect, click **Confirm** to restart the device.

## 12.3 CMS Configuration

### Description

You can view the existing protocol name and version number of the current device on the **Configuration > Protocol > CMS Configuration** page, as shown in Figure 12-3. Table 12-3 describes the protocol-related parameters.

Figure 12-3 CMS Configuration page

**CMS Configuration**

Protocol Name	ONVIF
Protocol Version	v17.06
Protocol Software Version	v17.06_build000276

Profile G	<input type="checkbox"/> OFF
Profile Q	<input type="checkbox"/> OFF
IVA Switch	<input checked="" type="checkbox"/> ON
Media2	<input type="checkbox"/> OFF
ImageEvent	<input type="checkbox"/> OFF
active onvif	<input checked="" type="checkbox"/> ON

**Table 12-3** Protocol-related parameters

Parameter	Description
Protocol Name	Type of the access protocol.
Protocol Version	Version number of the access protocol.
Protocol Software Version	Software version number of the access protocol.
Profile G	Enable ONVFI Profile G
IVA Switch	Enable IVA Switch
Media 2	Enable Media 2
Image Event	Enable image event
Active onvif	Enable active onvif

## 12.4 Multicast Parameters

### Description

You can set multicast IP, video port, audio port and source port in multicast parameter page.

### Procedure

Step 1 Choose **Configuration > Protocol > Multicast Param.**

The **Multicast Param** page is displayed as shown in Figure 12-4. Table 12-4 describes the parameters on the **Multicast Param** page.

Figure 12-4 Multicast Param page

**Multicast Param**

Stream ID	1
Video Port	25330
Video Address	238.255.255.255
Audio Port	25430
Audio Address	238.255.255.255
Source Port	25530
Source Address	238.255.255.255

Refresh    Apply

---

**Multicast Param**

Stream ID	1
IP	238.255.255.255
Video Port	25330
Audio Port	25430
Source Port	25530

Refresh    Apply

**Table 12-4** Parameter description

Parameter	Description	Setting
Stream ID	ID of stream.	[Setting method] Select a value from the drop-list box. [Default value] 1
IP	IP address that receive multicast data.	[Setting method] Enter a value manually. [Default value] 238.255.255.255
Video Port	Port that receive video data.	[Setting method] Enter a value manually. [Default value] 25330

Parameter	Description	Setting
Audio Port	Port that receive audio data.	[Setting method] Enter a value manually. [Default value] 25430
Source Port	Port that receive source data.	[Setting method] Enter a value manually. [Default value] 25530

Step 2 Click **Apply**.

It shows that parameters are set successfully and take effect after restarting., the system will save the settings.

# 13 Query Device Logs

## 13.1 Query Operation Logs

### Description

Operation logs record user operations and scheduled task commands during the running of the device. Operation logs can be classified into the following types: permission management, system maintenance, device configuration, recording operation, video control, and real-time video.

### Procedure

Step 1 Choose Configuration > Device Log > Operation Log.

The **Operation Log** page is displayed, as shown in Figure 13-1.

Figure 13-1 Operation Log page

 **Operation Log**

Operation Log All Type

Begin Time 2022-04-11 09:43:47

End Time 2022-04-12 09:43:47

Download Query

Time	User Name	Log Info
2022-04-12 09:34:04	admin	Stop video
2022-04-12 09:34:04	admin	Stop IntelligenceAnalyse Stream
2022-04-12 08:37:01	admin	Start IntelligenceAnalyse Stream
2022-04-12 08:37:01	admin	Start video
2022-04-12 08:36:58	admin	Login succeed
2022-04-12 06:14:46		Startup Device
2022-04-11 20:28:25	admin	Start AI Multiobject Detect Stream
2022-04-11 20:28:25	admin	Start video
2022-04-11 20:04:02	admin	Start AI Multiobject Detect Stream
2022-04-11 20:04:01	admin	Start video

<< 1 >>

Step 2 Set the search criteria.

1. Select the type of operation logs to be queried from the **System Log** drop-down list box.
2. Click the **Begin Time** and **End Time** text boxes respectively.  
A time setting control is displayed.
3. Set the start time and end time as required.

4. Enter the corresponding user name that is registered with the device from the **User Name** drop-down list box.

Step 3 Click **Query**.

The operation logs related to the specified user are displayed.

Step 4 Download the operation logs.

1. Set the start time, end time and log type.
2. Click **Download** on the right of the page.

The log link and the message "Please download log by 'save as 'in the right key" are displayed.

3. Right-click the link and save the logs.

 **NOTE**

An operation log is named as **Operation Log** by default and in the following format:

*Operation time user(User name) Operation information*

For example:

2012-06-20 13:40:39 user() Start Up Device

2012-06-20 13:42:46 user(admin) Configure Device Name

2012-06-20 13:43:16 user(admin) Configure Alarm In

## 13.2 Query Alarm Logs

### Description

An alarm log records information about an alarm generated on a device, including the security, disk, and recording alarms.

### Procedure

Step 1 Choose Configuration > Device Log > Alarm Log.

The **Alarm Log** page is displayed, as shown in Figure 13-2.

Figure 13-2 Alarm Log page

 **Alarm Log**

---

Alarm Type All ▼

Begin Time 2022-04-11 09:45:36

End Time 2022-04-12 09:45:36

Alarm Begin Time	Alarm End Time	Log Info	Source ID
2022-04-12 06:14:49	2022-04-12 06:14:59	Record storage failed	1
2022-04-11 10:13:36	2022-04-11 10:13:46	Record storage failed	1

⏪ <
1 ▼
> ⏩

Step 2 Set the search criteria.

1. Click the **Begin Time** and **End Time** text boxes respectively.  
A time setting control is displayed.
2. Set the start time and end time as required.
3. Select the type of the alarm logs to be queried from the **Alarm Type** drop-down list box.

Step 3 Click **Query**.

The alarm logs of the specified type are displayed.

Step 4 Download the alarm logs.

1. Set the start time and end time.
2. Select a log type.
3. Click **Download** on the right of the page.  
The log link and the message "Please download log by 'save as 'in the right key" are displayed.
4. Right-click the link and save the logs.

 **NOTE**

An alarm log is named as **Alarm Info** by default and in the following format:

*Alarm start time -> Alarm end time Alarm information Source ID*

For example:

2012-03-17 16:31:17 -> 2012-03-17 16:32:29 occur motion detect alarm Source Id(1:1)

2012-03-17 16:35:31 -> 2012-03-17 16:35:41 occur motion detect alarm Source Id(1:1)

## 13.3 Collect All Logs

### Description

You can collect logs about a device, which help you analyze and solve possible problems occurring on the device. The logs include overview information, key parameters, operation logs, alarm logs, upgrade logs, and debugging logs.

### Procedure

Step 1 Choose Configuration > Device Log > Collect all Log.

The **Collect all log** page is displayed, as shown in Figure 13-3.

Figure 13-3 Collect Log page

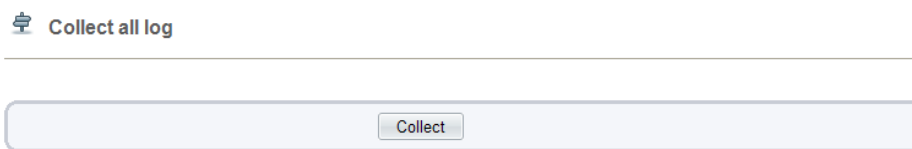

Step 2 Collect logs with one click.

1. Click **Collect**, the download page is displayed.
2. Select the path to save the logs.

# 14 Maintain the Device

## 14.1 Restart a Device

### Description

Restart a device including but not limited to the following situations:

- The device parameters are set incorrectly, and the device cannot work properly.
- A user needs to reset device parameters and make it to take effect.
- A device needs to be restarted remotely.

### Procedure

Step 1 Choose Configuration > Maintenance.

The **Camera Maintenance** page is as shown in Figure 14-1.

Figure 14-1 Camera Restart page

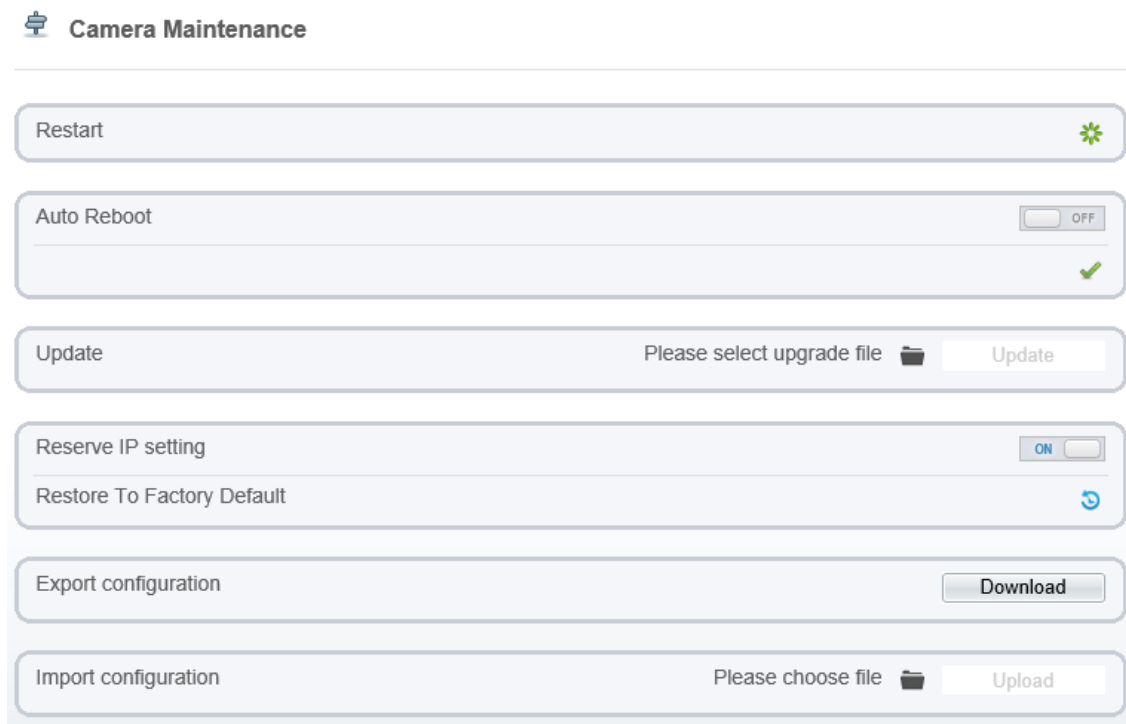

Step 2 Click .

The message "Are you sure to restart?" is displayed.

Step 3 Click **OK**.

The device is restarted successfully five minutes later.

## 14.2 Auto Reboot

Step 1 Choose Configuration > Maintenance.

The **Camera Maintenance** page is displayed, as shown in Figure 14-1.

Step 2 Enable the auto reboot, choose the reboot interval from drop-down list.

There are three option, every day/every week/every month.

Figure 14-2 Camera auto reboot

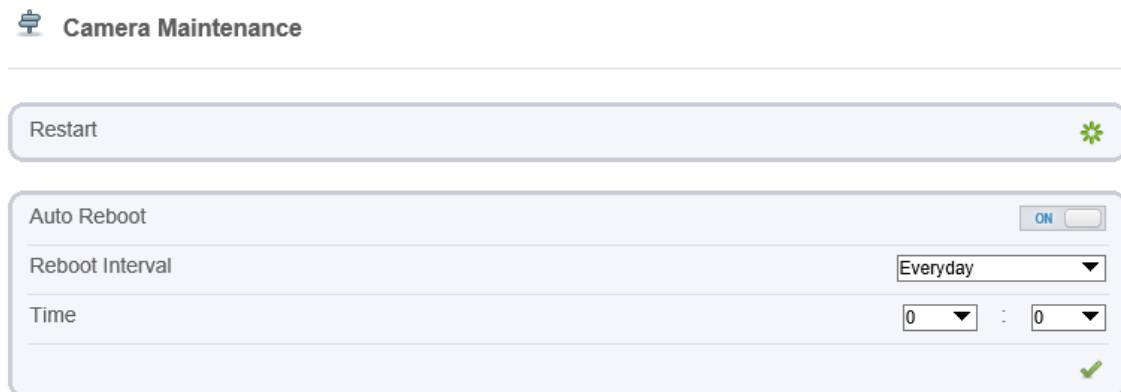

The screenshot shows the 'Camera Maintenance' interface. At the top, there is a 'Restart' button with a green gear icon. Below it, the 'Auto Reboot' section is visible, featuring a toggle switch set to 'ON'. Underneath, the 'Reboot Interval' is set to 'Everyday' via a dropdown menu. The 'Time' field is set to '0' for both hours and minutes. A green checkmark is located at the bottom right of the configuration area.

Step 3 Click **OK**.

The device is restarted successfully five minutes later.

## 14.3 Update the Software Package

### Description

You can update the software package from web.

### Procedure

Step 1 Choose Configuration > Maintenance.

The **Device Maintenance** page is displayed.

Step 2 Click  to select the upgrade file.

Step 3 Click **Update**.

- If the message "Upgrade success! The device is rebooting, please login later!" is displayed, the program updated successfully and the device is rebooted.
- If other information is displayed, select the upgrade package correctly.



Don't lose power during the upgrade, if the power off, the camera maybe malfunction.

---

## 14.4 Restore Device to Factory Settings

### Description

You can restore a device to factory settings including but not limited to the following situations:

- The device parameters are set incorrectly, and the device cannot work properly.
  - A user needs to reset device parameters.
  - All parameters must be restored to the factory settings.
- 



After you clicking , all parameters (you can choose whether to reserve the IP address) will be restored to the factory settings. Use this function carefully.

---

### Procedure

Step 1 Choose Maintenance.

The **Device Maintenance** page is displayed.

Step 2 Click .

The message "Are you sure to restore?" is displayed.

Step 3 Click **OK**.

The device is restored to the factory settings.

## Restoring Factory Settings Using Reset Button

You can restore a device to factory settings by continuously pressing the Reset button for 5 seconds.

### Procedure

If your camera comes with multi-head cable with Reset button: make sure the device is powered on. Press and hold the Reset button for 5 seconds. Release the button. After some time the device will restart using factory default settings.

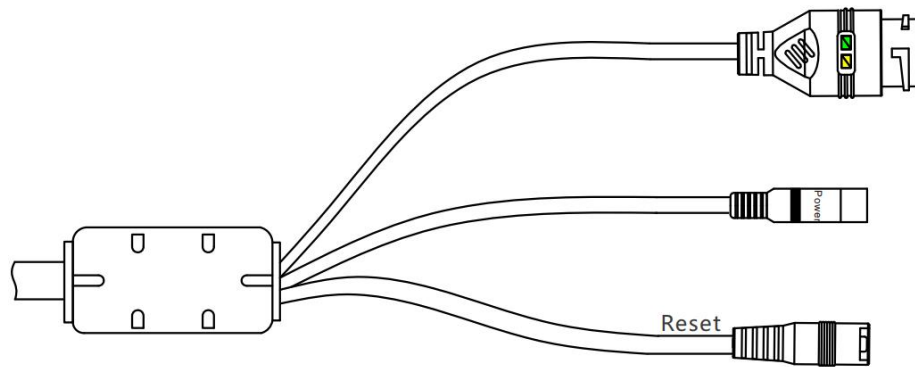

If your camera does not have multi-head cable with Reset button: Open the camera dome and locate the reset button next to SD card slot. Make sure the device is powered on. Press and hold the Reset button for 5 seconds. Release the button. After some time the device will restart using factory default settings.

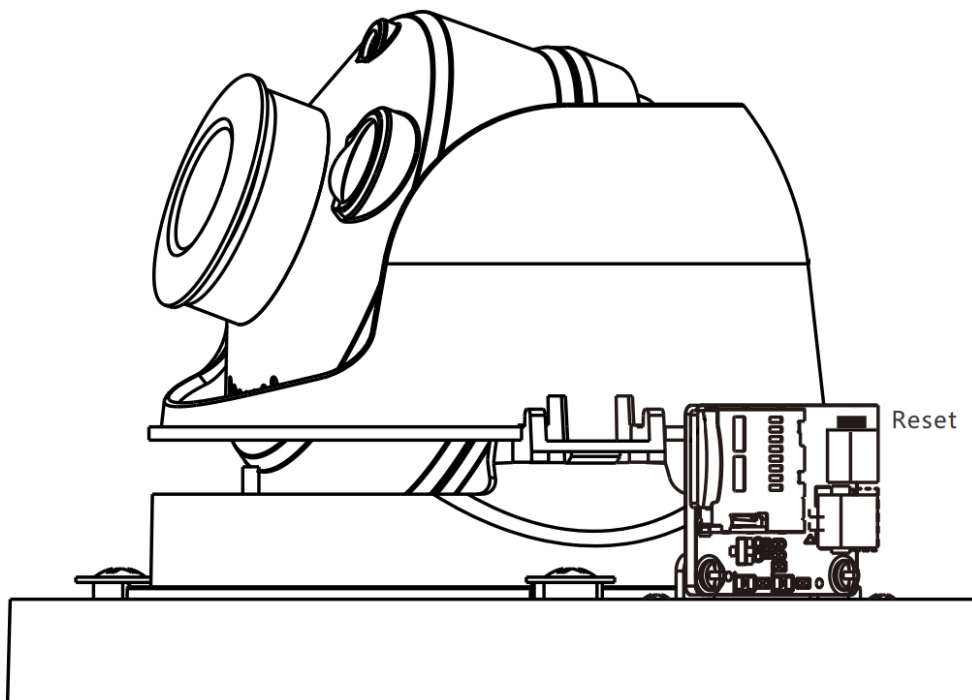

# 14.5 Export / Inport Configuration

## Description

You can export configuration to local hard driver, when you configurate the same model cameras or the current camera, import the configuration file (config.bin) directly

## Procedure

Step 1 Choose Maintenance.

The **Device Maintenance** page is displayed.

Step 2 Click **Download** to download the configuration file.

Save the file to local hard driver follow the prompts.

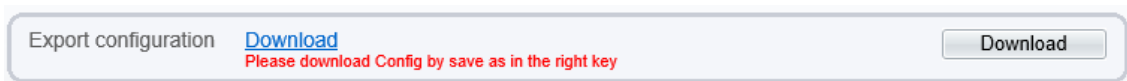

Step 3 Import configuration: choose the file on local hard driver, click **Upload** to upload file.

The tip will show after the configuration file uploading finish.

### Tip

Upload config file succeeded, The device is rebooting, please login later!

OK

Step 4 Click OK to finish.

# 15 Local Configuration

## Description

You can set folder to save the snapshots and records to local. This function only can be used in IE browser.

## Procedure

Step 1 Choose **Configuration > Local Config**.

The **Local Config** page is displayed, as shown in Figure 15-1.

Figure 15-1 Local Config page

The screenshot shows two instances of the 'Local Config' page. The top instance shows the initial configuration with the following values:

Field	Value
Snapshot picture format	jpg
SnapShot Save Path	D:\LocalStorage\
Local Record Save Path	D:\LocalStorage\
Local Record File Size(8-128M)	64

The bottom instance shows the configuration after changes, with the following values:

Field	Value
Snapshot picture format	jpg
SnapShot Save Path	C:\Users\Administrator\Downloads
Local Record Save Path	C:\Users\Administrator\Downloads
Local Record File Size(8-128M)	128
Hardware Decode	OFF

Step 2 Select picture format from the drop-down box.

Step 3 Set snapshot save path.

Step 4 Set local record save path

Step 5 Set local record file size(8-128 M), the default value is 64. Or enable the Hardware Decode.

Step 6 The message "Apply success!" is displayed, and the system saves the settings.

# 16 Troubleshooting

Table 16-1 describes the common faults and solutions.

**Table 16-1** Common faults and solutions

Common Fault	Possible Cause	Solution
When you enter the device IP address in the address box of your Web browser and press <b>Enter</b> , the message "There is a problem with this website's security certificate." is displayed.	The certificate is not installed.	Click <b>Continue to this website (not recommended)</b> .
The web management system cannot be accessed.	The network is disconnected.	<ul style="list-style-type: none"> <li>• Connect the PC directly to the camera, and verify that the web management system can be accessed.</li> <li>• Run the <b>ping</b> command to verify that the camera is reachable.</li> </ul>
	The IP address is used by another device.	Connect the PC directly to the camera and configure the IP address of the camera.
	The IP addresses of the PC and IP camera are on different networks.	Check the IP address, subnet mask, and gateway settings on the IP camera, and change the settings as required.
The PTZ or dome cannot be controlled.	The protocol, baud rate, or address is incorrect.	Change the protocol, baud rate, and address in the web management system to those used by the PTZ or dome.
	The signal cable is not properly connected.	Check the signal strength and connect the signal cable properly.
After the IP camera is upgraded, the web management system cannot be accessed.	The browser cache is not deleted.	<p>To delete the browser cache, please search and follow the instructions for your specific Web browser.</p> <p>After deleting browser cache, login to the web management system again.</p>
The IP camera cannot be upgraded.	<ul style="list-style-type: none"> <li>• The network is disconnected.</li> <li>• The network settings are incorrect.</li> </ul>	<ul style="list-style-type: none"> <li>• Confirm that the upgrade network is connected.</li> <li>• Check the network settings.</li> </ul>
	The upgrade package is incorrect.	Obtain the correct upgrade package and upgrade the IP camera again.

# A Acronyms and Abbreviations

---

## A

ADSL Asymmetric Digital Subscriber Line

## C

CBR Constant Bit Rate

CGI Common Gateway Interface

CMS Central Management System

## D

DHCP Dynamic Host Configuration Protocol

DNS Domain Name Server

DDNS Dynamic Domain Name Server

## F

FTP File Transfer Protocol

## G

GAMA Graphics Assisted Management Application

## H

HTTP Hyper Text Transfer Protocol

HTTPS Hypertext Transfer Protocol Secure

## I

ID Identity

ISO International Standard Organization

IP Internet Protocol

IPC Internet Protocol Camera

## L

LPS Limited Power Source

## M

MJPEG Motion Joint Photographic Experts Group

MAC Media Access Control

MTU Media Transmission Unit

## N

NAS Network Attached Storage

NTP Network Time Protocol

NTSC National Television Standards Committee

