



MV7i

Smart Microphone and Interface

Manual for the MV7i. Learn how to set up, configure, and use the MV7i podcast microphone and interface.
Version: 1.2 (2025-C)

Table of Contents

MV7i Smart Microphone and Interface	3	LED Behavior	10
Update Firmware	3	Mounting Instructions	11
Important Safety Instructions for Passive Microphones	3	Troubleshooting	11
SAFETY PRECAUTIONS	3	Firmware Update	13
General Description	4	Keep equipment connected during updates	13
Features	4	System Requirements	13
Recording Setups	5	System Requirements and Compatibility: Mac	14
Inputs and Outputs	6	System Requirements and Compatibility: Windows	14
Customization in MOTIV Mix	7	System Requirements and Compatibility: iOS	14
Global Tab	7	System Requirements and Compatibility: Android	14
Mic Tab	7	Additional Resources	14
Input Tab	8	Specifications	14
Audio Output Modes	9	MV7i Yoke Assembly	17
DSP Modes in MOTIV Mix	9	Accessories	18
LED Touch Panel	10	Furnished Accessories	19
Split LED Modes	10	Replacement Parts	19
Combined LED Modes	10	Certifications	19
		Information to the user	19
		Environmental Regulatory Information	21

MV7i

Smart Microphone and Interface



Update Firmware

For the best experience, keep the firmware on your device [up to date](#).

Important Safety Instructions for Passive Microphones

SAFETY PRECAUTIONS

Before using this product, please read and save the enclosed warnings and safety instructions.

	<p>WARNING: Ignoring these warnings may cause severe injury or death as a result of incorrect operation.</p> <p>If water or other foreign objects enter the inside of the device, fire or electric shock may result. Do not attempt to modify this product. Doing so could result in personal injury and/or product failure.</p>
	<p>CAUTION: Ignoring these cautions may cause moderate injury or property damage as a result of incorrect operation.</p> <p>Never disassemble or modify the device, as failures may result. Do not subject to extreme force and do not pull on the cable or failures may result. Keep the microphone dry and avoid exposure to extreme temperatures and humidity.</p>



High sound pressure

Hearing damage risk

To prevent possible hearing damage, do not listen at high volume levels for long periods.

WARNING

LISTENING TO AUDIO AT EXCESSIVE VOLUMES CAN CAUSE PERMANENT HEARING DAMAGE. USE AS LOW A VOLUME AS POSSIBLE. Over exposure to excessive sound levels can damage your ears resulting in permanent noise-induced hearing loss (NIHL). Please use the following guidelines established by the Occupational Safety Health Administration (OSHA) on maximum time exposure to sound pressure levels before hearing damage occurs.

90 dB SPL	95 dB SPL	100 dB SPL	105 dB SPL
at 8 hours	at 4 hours	at 2 hours	at 1 hour

110 dB SPL at ½ hour	115 dB SPL at 15 minutes	120 dB SPL Avoid or damage may occur
---	--	--

General Description

The Shure MV7i is a dynamic USB-C microphone with a built-in audio interface, engineered for seamless 2-channel audio recording or streaming on computers, tablets, or smartphones. Connect an XLR microphone or an instrument via ¼" directly in to the MV7i, then connect the MV7i via USB-C to the device of your choice, and effortlessly manage both channels using the MOTIV Mix Desktop app or MOTIV Mobile app. Capture broadcast-quality sound on both channels and use cutting-edge DSP features, including Voice Isolation Technology, Auto Level Mode with SmartGate™, Real-time Denoiser, and Digital Popper Stopper™.

Encased in a sleek, all-metal design with an adjustable yoke, the MV7i streamlines your audio setup by delivering superior sound quality with minimal cabling.

Features

- First-of-its-kind microphone and interface in one for digital recording of 2 channels without the need for an external audio interface.
- Optimized frequency response for rich and natural vocal reproduction.
- Highly directional dynamic element with proven Voice Isolation Technology that separates your voice from unwanted background sounds.
- Combo XLR & ¼" Input supports dual-channel recording/streaming with XLR microphones or instruments. Supports mono (XLR or TRS) and stereo (TRS) input.
- Provides +60 dB of gain and 48 V of Phantom Power, suitable for any dynamic or condenser mic.
- Advanced DSP features* to record broadcast quality audio in imperfect spaces, independently configurable with MOTIV Mix Desktop app and MOTIV mobile apps:
 - Auto Level Mode with SmartGate™: recalibrates mic gain in real-time based on distance, volume, and room dynamics for consistent audio output. Intelligently prevents overlapping dialogues when recording with 2 channels.
 - Real-time Denoiser: reduces persistent ambient noise for clearer audio.
 - Digital Popper Stopper™: eliminates harsh plosive sounds in real-time.
 - Adjustable Reverb: select from three types of reverb (Plate, Hall, Studio) with adjustable intensity.
 - Customizable tone and sound signature, gain control, EQ, compression and limiter for each channel.
- Customizable dual-display LED Touch-to-Mute Panel: Configure LED color display into 3-color live metering, 1-color solid or pulsing display with millions of hues to choose from. Instantly mute either the MV7i or the Input by touching the panel.
- Up to 24 bit/48 kHz digital recording and streaming.
- Mac and Windows Compatible: works with Mac, Windows, and select USB-C iOS and Android devices.
- Zero-latency Monitoring: built-in 3.5 mm headphone jack for mixdown monitoring of both inputs.
- Select your preferred recording output via MOTIV Apps
 - Mixdown Mode (Default): combines mic and mono input audio into one mono audio output.
 - Multi-Track Mode: renders two mono audio tracks. One for the mic and one for the input.
 - Stereo Mode: combines mic and stereo input audio into one stereo audio track. Preserves the stereo audio from the Input and places mic input in both left and right channels.
- Rugged, all-metal construction for outstanding reliability.
- Adjustable integrated yoke for easy positioning on standard 5/8"-27 threaded stands or booms.

*Auto Level Mode with SmartGate, Real-time Denoiser and Digital Popper Stopper will be disabled when MV7i detects an instrument input via ¼".

Recording Setups

The MV7i combines a microphone with an interface in one condensed piece of hardware.

Connect an XLR or ¼" Tip Sleeve (TS)/Tip Ring Sleeve (TRS) input to the MV7i via the combo connector.

The MV7i has a USB-C output. Connecting the microphone to a computer, phone, or tablet via USB-C will connect both the MV7i microphone and any other connected input to your computer, phone, or tablet.

To set the MV7i up for recording:

1. Plug the included USB-C cable into your MV7i.
2. Connect the other end of the USB-C cable to your compatible laptop, phone, or tablet.
3. Plug your headphones into the monitor output.
4. To connect an additional XLR or ¼" TS/TRS input, plug the device into the combo connector on the MV7i.

For the best results with XLR inputs, use the highest-quality XLR cable available to you. A high-quality cable is more likely to connect securely to the combo connector and prevent static. Lower-quality cables can cause audio quality issues and interfere with the built-in MV7i microphone.

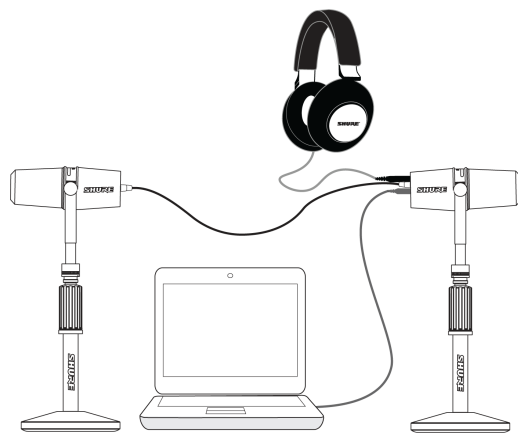

Connecting an XLR Input

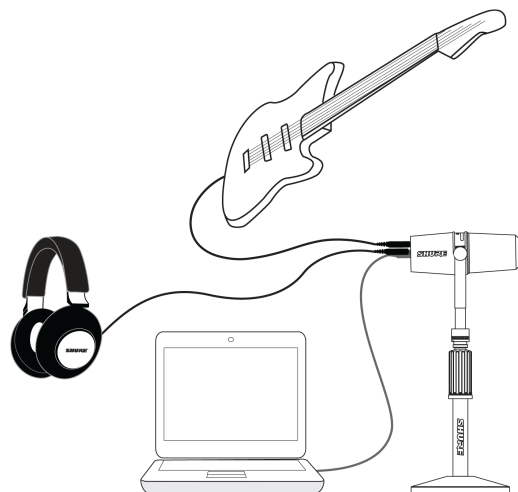

Connecting a ¼" TS/TRS Input

Tips for Recording A Podcast with 2 People

When recording speech on the MV7i, Digital Signal Processing (DSP) like Auto Level Mode and SmartGate improve your sound. Enable them in MOTIV Mix, or see [Customization in MOTIV Mix](#) for more information on the available DSP. For these DSP features to perform as well as possible, set up your podcast recording space with the following tips in mind:

- Record separate sound sources with each microphone. The MV7i microphone should record one source, like the host of a podcast, while the connected XLR microphone records another source, like a guest on a podcast.
- Avoid pointing the microphones at each other. Point the microphones away from each other or pointing in the same direction.
- If your microphones are pointed 180 degrees from each other, like across a table, place them at least 1 foot apart.
- If your microphones are pointed 90 degrees from each other, like at adjacent sides of a table, place them at least 2 feet apart.
- If your microphones are pointing in the same direction, place the microphones at least 3 feet apart.

Note: These suggested configurations are ideal for microphones with a cardioid polar pattern. Check the user guide for the microphone you are connecting to the MV7i for information on polar patterns.

Inputs and Outputs

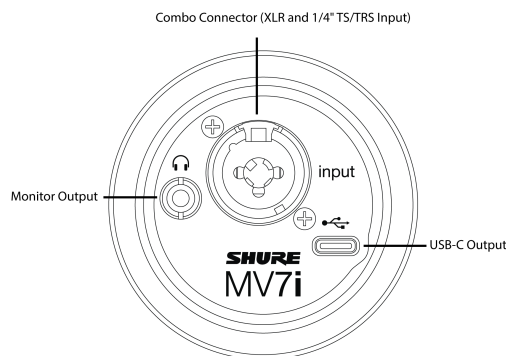

XLR Input

The combo connector on the back of the MV7i supports an XLR input. XLR connections are common for microphone-level inputs.

For the best results, use the highest-quality XLR cable available to you. A high-quality cable is more likely to connect securely to the combo connector and prevent static. Lower-quality cables can cause audio quality issues and interfere with the built-in MV7i microphone.

The MV7i can supply phantom power to connected XLR inputs.

Note: Phantom power is enabled by default on the MV7i. Phantom power may damage some microphones that don't use it. Refer to the user guide of your connected device to determine if it needs phantom power.

Disable or enable phantom power from MOTIV Mix by selecting the settings wheel next to the MV7i and going to the Input tab.

1/4" Tip Sleeve (TS)/Tip Ring Sleeve (TRS) Input

The combo connector on the back of the MV7i supports a 1/4" Tip Sleeve/Tip Ring Sleeve input. These connections are common for line level or instrument level devices such as guitars, keyboards, or synthesizers.

3.5 mm Monitor Output

Connect headphones or earphones to the MV7i for latency-free monitoring.

USB-C Output

Use the included USB-C cable to connect to your computer, phone, or tablet. Audio from both the MV7i microphone and any connected input will pass to the connected device via the USB-C cable.

Customization in MOTIV Mix

In the [MOTIV Mix](#) software, you can custom-tailor the settings on the MV7i and any connected inputs. Adjust levels, enable DSP, and customize the LED panel from MOTIV Mix. To adjust MV7i settings in MOTIV Mix, select the gear icon next to the device name or in the input panel on the mixer.

MV7i remembers the last-used settings for the XLR and ¼" TS/TRS inputs separately so that you can plug in your device and go. When an XLR input is connected, the MV7i will recall the settings from the last time an XLR input was configured. When a ¼" input is connected, the MV7i will recall the settings from the last time a ¼" input was configured.

There are three tabs in the MV7i settings panel: the Global tab, the Mic tab, and the Input tab. The Global tab contains global settings that apply to the microphone and any connected input. The Mic and Input tabs contain settings specific to that input.

For a full description of the features and capabilities of MOTIV Mix, see the [MOTIV Mix user guide](#).

Global Tab

The Global tab in MOTIV Mix contains global settings that adjust the MV7i and any connected input.

Hardware Configuration Settings

- **Audio Output Mode:** select between Mixdown, Multi-Track, and Stereo modes for the output as you record. Stereo mode is only available when a ¼" TRS input is detected. See the [Audio Output Modes](#) topic for more information on Mixdown, Multi-Track, and Stereo modes.
- **Monitor Mix:** move the sliders to adjust the levels of mic, combo connector input, and computer playback sound sources in the headphones connected to the device.
- **LEDs:** select the LED mode and set the color of the LED panel. See the [LED Touch Panel](#) topic for more information on the LED panel.
- **Reset to Defaults:** reset the MV7i settings to the default settings.

Digital Signal Processing (DSP) Settings

- **Smart Gate:** works with Auto Level Mode to dynamically reduce the volume of a channel when either of the two users fall silent, minimizing crosstalk and guaranteeing that concurrent conversations do not disrupt the separate audio streams.

Smart Gate is designed specifically for speech applications, like podcasting or livestreaming. Using Smart Gate for singing or instrumental recordings may result in artifacts in the recording.

- **Reverb:** add studio, plate, or hall reverb to the output. Adjust the intensity of the reverb with the slider.

Mic Tab

Adjust settings on the MV7i microphone in the Mic tab.

Hardware Configuration Settings

- **Mute/Unmute:** click to mute and unmute the MV7i microphone. The MV7i can also be muted or unmuted by touching the LED panel anywhere in Combined LED modes or on one side in Split LED modes. See more about the touch-to-mute LED panel feature in the [LED Touch Panel](#) topic.
- **Mute lock:** select the lock icon to lock the MV7i in a muted or unmuted state. When mute lock is on, the MV7i cannot be muted or unmuted by touch and must be unlocked in MOTIV Mix to restore the touch-to-mute function.

Digital Signal Processing (DSP) settings

Auto-level mode, Real-time Denoiser, and Popper Stopper are designed for speech applications, like podcasting or livestreaming. Leaving these features enabled for singing or instrumental applications may result in artifacts in the recording.

- **Mode:** select between Speech, Singing, or Instrument mode to automatically adjust the DSP features in MOTIV Mix to fit your application. See more about the different modes in the [Modes in MOTIV Mix](#) topic.
- **Gain:** enable Auto-level mode for MOTIV Mix to automatically adjust your levels as you record. Disable Auto-level mode to adjust gain manually via the slider. In manual mode, select the lock icon to lock your gain at the set level.
- **Compressor** (available when Auto-level mode is turned off): select light, medium or heavy compression to reduce the difference between the loudest and softest parts of the signal, making the overall sound louder and more consistent in volume.
- **Limiter** (available when Auto-level mode is turned off): enable or disable a limiter. Use a limiter to prevent distortion from level peaks in your recording.
- **Tone:** use the slider to adjust your tone between dark, natural, and bright.
- **Reverb:** apply reverb to your output or to the monitor output on the MV7i. Adjust reverb parameters in the Global tab.
- **Real-time Denoiser:** enable the Real-time Denoiser to help reduce unwanted noise.
- **Popper Stopper:** enable the Popper Stopper DSP to detect and reduce plosives.
- **High-pass Filter:** reduce unwanted low-frequency rumbling noise with a high pass filter at 75 Hz or 150 Hz.

Input Tab

The Input tab in MOTIV Mix hosts configurable settings for a connected XLR or ¼" TRS input.

Hardware Configuration settings

- **Mute/Unmute:** click the button to mute and unmute the connected device. Select the lock icon to mute lock the input. In this state, the connected device cannot be unmuted by touching the LED panel and must be unlocked in MOTIV Mix to restore the touch-to-mute function. The connected device can also be muted or unmuted by touching the LED panel anywhere in Combined LED modes or on side B in Split LED modes. See more about the touch-to-mute LED panel feature in the [LED Touch Panel](#) topic.
- **Input Type:** select the input type that matches the device you're connecting to the MV7i. The MV7i supports XLR or ¼" TS/TRS inputs.
- **XLR Phantom Power:** enable phantom power if the connected XLR device requires it to operate. MV7i only supports phantom power through the XLR input. Refer to your device's user guide to determine if it needs phantom power.

Digital Signal Processing (DSP) Settings

Auto-level mode, Real-time Denoiser, and Popper Stopper are designed for speech applications, like podcasting or livestreaming. Leaving these features enabled for singing or instrumental applications may result in artifacts in the recording.

- **Mode:** select between Speech, Singing, or Instrument mode to automatically adjust the DSP features in MOTIV Mix to fit your application. See more about the different modes in the [Modes in MOTIV Mix](#) topic.
- **Gain:** enable Auto-level mode for MOTIV Mix to automatically adjust your levels as you record. Disable Auto-level mode to adjust gain manually via the slider. In manual mode, select the lock icon to lock your gain at the set level.

- **Compressor** (available when Auto-level mode is turned off): select light, medium or heavy compression to reduce the difference between the loudest and softest parts of the signal, making the overall sound louder and more consistent in volume.
- **Limiter** (available when Auto-level mode is turned off): enable or disable a limiter. Use a limiter to prevent distortion from level peaks in your recording.
- **Tone**: use the slider to adjust your tone between dark, natural, and bright.
- **Reverb**: apply reverb to your output or to the monitor output on the MV7i. Adjust reverb parameters in the Global tab.
- **Real-time Denoiser**: enable the Real-time Denoiser DSP to help reduce unwanted noise.
- **Popper Stopper**: enable the Popper Stopper DSP to detect and reduce plosives.
- **High-pass Filter**: reduce unwanted low-frequency rumbling noise with a high pass filter at 75 Hz or 150 Hz.

When using the Stereo audio output mode with a ¼" input, only the Gain and Mute settings are available. To use other settings with a ¼" input, change the audio output mode to Mixdown or Multi-Track in the Global tab.

Audio Output Modes

In MOTIV Mix, you can select between three audio output modes depending on your application: Mixdown, Multi-Track, and Stereo. Select an output mode in the Global settings tab in MOTIV Mix. The default audio output mode is Mixdown mode.

Mixdown mode treats both the MV7i microphone and the connected input as mono inputs. These inputs are mixed together to one mono mix output. If a stereo ¼" TRS cable is connected to the combo connector, the left channel is summed into the mono channel. Mixdown mode is the default setting for the MV7i.

Multi-Track mode sets the MV7i microphone to the left channel and the connected input to the right channel of a stereo channel in the recording. If a stereo TRS cable is connected to the combo connector, the left channel of the input is summed into the right channel of the recording.

Stereo mode is available for setups that include a ¼" TRS connection. In Stereo mode, the MV7i microphone will route to left and right outputs and the ¼" connection will route left audio to left outputs and right audio to right outputs. When using Stereo mode while an XLR cable is connected to the combo connector, the output will be the same as Mixdown mode.

DSP Modes in MOTIV Mix

MOTIV Mix has three digital signal processing (DSP) presets designed to enhance any application. Record speakers for podcasts or livestreams with Speech mode, singers with Singing mode, and instruments with Instrument mode.

Each mode enables or disables DSP settings on the MV7i to fit your application. Presets are selected on a per-input basis. The MV7i recalls and applies the previous settings of the XLR and ¼" TS/TRS separately when it is connected. Any selected presets will remain enabled when the MV7i is turned off or restarted.

Speech mode configures the MV7i and connected inputs to optimize the sound of speech for podcasts, streaming, and other spoken applications. Speech mode enables the following features:

- Auto-Level Mode
- Real-time Denoiser
- Popper Stopper

By default, Speech mode is enabled for the MV7i and connected XLR inputs.

Singing mode optimizes the MV7i and connected inputs for singing. Singing mode enables the following features:

- Popper Stopper

Auto-Level Mode, Real-time Denoiser, and Smart Gate are turned off in Singing mode. Enabling these features for singing applications may result in audio artifacts in the recording.

Instrument mode preserves the raw sound of recorded instruments. Auto-Level Mode, Real-time Denoiser, and Popper Stopper are disabled in Instrument mode. Enabling these features when recording instruments may result in audio artifacts in the recording. By default, Instrument mode is enabled for connected ¼" inputs.

LED Touch Panel

Configure and customize LED mode, color, and brightness in the MOTIV Mix app. Select between Split or Combined live metering, pulsing, or solid patterns and customize the color of the LED panel. By default, the MV7i is configured to Combined Live Meter Color mode.

In Split modes, the LED panel is divided in half to display information about each input. Touching a side of the panel will mute the input associated with that side.

In Combined modes, the entire LED panel displays information about both inputs collectively. Touching the panel anywhere will mute both the MV7i microphone and the connected input.

When Mute Lock is enabled on the MV7i microphone or a connected input, that input will not mute or unmute when touching the LED touch panel. Instead, the LED panel will flash red 3 times. Disable Mute Lock in MOTIV Mix to enable touch-to-mute capabilities.

Split LED Modes

Split modes divide the LED touch panel into two sides. One side represents the MV7i microphone and the other side represents the input connected to the combo XLR or ¼" connector.

When using the MV7i in a Split mode with another input connected to the combo connector on the MV7i:

- Touch the MV7i microphone side to mute/unmute the microphone.
- Touch the combo connector input side to mute/unmute a connected input.
- Touch the center of the LED panel to mute/unmute all inputs.

Split mode can be set to Live Meter, Solid, or Pulsing modes.

In **Split Live Meter Color Mode**, each half of the LED panel displays the level of the associated input. The MV7i microphone side displays levels for the built-in microphone, and the combo connector side shows the levels of the connected input.

In **Split Solid Color Mode**, set distinct solid colors for each side of the LED panel.

In **Split Pulsing Color Mode**, set custom pulsing colors for each side of the LED panel.

Combined LED Modes

Combined modes show collective information about both the MV7i microphone and any input connected to the combo connector across the entire LED touch panel. Touch the panel anywhere to mute both inputs.

Combined mode can be set to Live Meter, Solid, or Pulsing modes:

In **Combined Live Meter Color Mode**, the LED touch panel displays the total level from the MV7i and any connected inputs.

In **Combined Solid Color Mode**, the LED touch panel displays one solid color.

In **Combined Pulsing Color Mode**, the LED touch panel displays one pulsing color.

LED Behavior

When the MV7i is in Split mode, a status LED indicator may only show on the side of the associated input. One side of the LED panel shows the status of the MV7i microphone. The other side shows the status the input connected to the combo connector.

Red, amber, and green ripples out from the center and back in: The MV7i is powering on via USB-C.

Green center: The MV7i successfully connected to a computer, tablet, or phone via USB-C.

Amber flashing center: The MV7i failed to connect via USB-C. Unplug the microphone, make sure your computer or device is awake, and then plug it back in. You may need to allow the microphone in your device settings.

Green, amber, and red ripples out from the center: A device has been connected to the combo connector on the MV7i.

Red, amber, and green ripples in from the edges: A device has disconnected from the combo connector on the MV7i.

White ripples out from the center: A device has been connected to the combo connector input on the MV7i with Phantom Power enabled.

White ripples in from the edges: A device has disconnected to the combo connector on the MV7i with Phantom Power enabled.

Red ripples from the center across the entire panel: The MV7i microphone and any connected combo connector input are muted. Touch the panel to unmute, or unmute the microphone from your device.

Red ripples from the center on one side: The MV7i microphone or connected input associated with that side of the panel is muted. Touch that side of the panel to unmute, or unmute the microphone or input from your device.

Red flashes 3 times when touched: The MV7i is mute locked and cannot be unmuted by touching the panel. Turn off Mute Lock in MOTIV Mix.

Amber pulses slowly: The firmware on the MV7i is updating.

Keep the microphone connected while the firmware is updating.

Mounting Instructions

The MV7i microphone comes equipped with a 5/8"-27 threaded mount, the thread size most commonly found on microphone stands. This mount can be used with a microphone stand or hung from a boom. Some stands may require the included Euro stand adapter.

To easily flip the microphone orientation, remove the windscreen, loosen the screws, and rotate 180 degrees by gently turning the microphone end through the yoke.

Note: Be very careful not to unloosen the screws all the way.

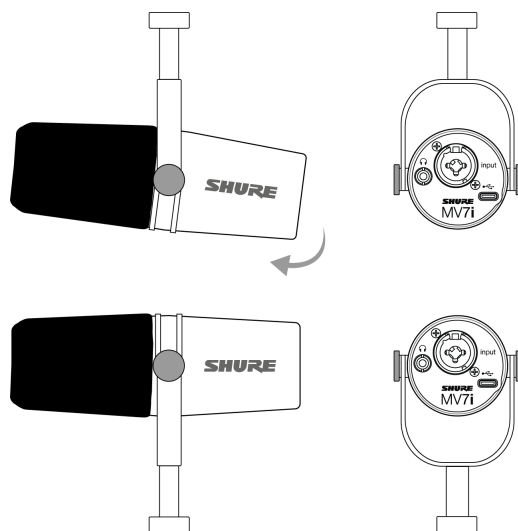

Troubleshooting

Issue	Solution
Recording has artifacts or sounds strange when recording singing or an instrument	<p>Check that the digital signal processing (DSP) settings for Auto Level Mode, Real-time Denoiser, Popper Stopper, and Smart Gate on the MV7i are disabled in MOTIV Mix. These DSP modes are optimized for speech applications and may affect the sound of singing or instrumental recordings.</p>
Audio is distorted in Auto Level Mode	<p>Select Auto Level Mode to allow the software to control gain settings. Experiment with different microphone placements. If distortion persists, consider using Manual mode to adjust your sound.</p>
Audio is distorted in Manual Mode	<p>Audio distortion usually comes from overloading the microphone, which causes clipping. Lower your mic gain for the best sound recording.</p>
Audio sounds higher or lower pitch than normal.	<p>Your microphone and computer have a sample rate mismatch. To adjust your computer sample rate settings, go to the Shure FAQ topic for information on correcting sample rate mismatch.</p> <p>Note: Windows update 10 v2004 (April 2020) solves this problem.</p>
The MV7i microphone is muted, but audio is still passing through.	<p>Low-quality XLR cables can cause this issue. Unplug any connected XLR input from the combo connector on the MV7i, power cycle the MV7i by unplugging the USB-C cable and plugging it back in, and consider upgrading or using a different XLR cable to connect an input to the combo connector.</p>
Microphone is plugged in, but not detected.	<p>Unplug and reconnect the cable so that the app recognizes the microphone. You'll know that the connection is made when the LED panel turns green after connecting and powering on.</p>
You hear no audio even though the desktop application is displaying the correct	<p>Check the Monitor Mix blend. Move the Monitor Mix sliders up to hear the audio going into the mic and the audio being played back at the same time.</p>

Issue	Solution
micro- phone.	
MV7i isn't working with Microsoft Teams on Mac.	<p>Check what version of MacOS the Mac is on. Currently, Microsoft Teams on MacOS 15 (Sequoia) has trouble supporting any external microphones. To continue to pass audio in Teams calls with your MV7i, try these workarounds:</p> <p>Keep the Teams audio control panel open during your call.</p> <p>Set both the input and the output in Teams to the MV7i. Connect headphones to the monitor output on the MV7i to listen to your Teams call.</p>
Microphone has become detached from the yoke.	<p>See the MV7i Yoke Assembly Topic for step by step instructions for re-assembling your yoke and assorted washers. Correct washer assembly is crucial to ensure that your microphone is securely in place.</p>
General troubleshooting	<p>Quit and re-start the app.</p> <p>Reboot the computer, phone, or tablet.</p> <p>Check for a firmware update in MOTIV Mix, MOTIV for iOS and Android, or MOTIV Video for iOS and Android.</p>

Note: Contact Shure Service and Repair if you continue to experience any issues.

Firmware Update

Take advantage of additional features and design enhancements by updating the firmware in MOTIV Mix, MOTIV for iOS and Android, or MOTIV Video for iOS and Android when prompted.

When a firmware update is available, the Firmware Update Available button will appear in the settings panel of your MV7i n MOTIV Mix. Select the button to update your firmware.

Leave the MV7i plugged in until the firmware update is complete. The LED panel pulses amber while the firmware updates.

Contact Shure Service and Repair if you experience any issues.

Keep equipment connected during updates

Keep your MOTIV device connected to your computer or mobile device when updating to ensure that there are no update issues.

System Requirements

Check the MOTIV Mix app or MOTIV mobile apps for the latest information on system requirements and compatibility.

System Requirements and Compatibility: Mac

- MacOS 12 and higher
- Minimum 8 GB of RAM
- Minimum 20% of hard disk space

System Requirements and Compatibility: Windows

- Windows 10 and higher
- Minimum 8 GB of RAM
- Minimum 20% of hard disk space

System Requirements and Compatibility: iOS

- **iOS:** iOS 16 and higher (USB-C devices only)

System Requirements and Compatibility: Android

- Android 12.0 and higher

Android is a trademark of Google Inc.

Note: See the MOTIV Mix, MOTIV for iOS and Android, or MOTIV Video product pages for information on supported Android devices.

Additional Resources

- [Shure Knowledge Base FAQs](#)
- [Training from the Shure Audio Institute](#)
- [Microphone Techniques for Recording](#)
- [Houses of Worship Systems Guide](#)
- [Shure Performance & Production YouTube channel](#)
- [Shure Creators YouTube channel](#)

Download Shure Software

- [Software and firmware archive](#)

Specifications

MV7i Microphone

Transducer Type

Dynamic (moving coil)

Polar Pattern

Unidirectional (Cardioid)

Frequency Response

50 Hz to 16,000 Hz

USB-C Maximum SPL

128 dB SPL [2]

Sensitivity*(@ 1 kHz, open circuit voltage with USB-C connection)*

-33 dBV/Pa [1][2]

Adjustable Gain Range

0 to +36 dB

Digital Noise Floor*20 Hz to 20 kHz, A-weighted*

-118 dBFS (with Auto Level Mode and Real Time Denoiser enabled)

[1] 1 Pa=94 dB SPL

[2] At Minimum Gain

Input (XLR or 1/4")**Supported Types**

XLR and 1/4" Tip Sleeve (TS), 1/4" Tip Ring Sleeve (TRS)

Input Impedance

XLR	5.8 k Ω
1/4" TRS	1 M Ω

Adjustable Gain Range

Mixdown and Multi-track modes	0 to +60 dB
Stereo mode	0 to +40 dB

Maximum Input Level

XLR	-14 dBV
1/4"	7 dBV

Digital Noise Floor

XLR	-118 dBFS (with Auto Level Mode and Real Time Denoiser enabled)
1/4"	-97 dBFS (at 10 dB gain)

Phantom Power

Yes (+48 V DC)

System

On-Board DSP

Auto-Level Mode with SmartGate, Digital Popper Stopper, Real-time Denoiser, Tone Slider, Reverb, Compressor, Limiter, High-Pass Filter

USB Host Requirements

USB Audio Class 2 (UAC2), Powered through USB-C bus power (USB 2.0 or higher)

A/D Converter

24-bit, 48 kHz (16-bit, 44.1 kHz support for iOS)

Headphone Output

3.5 mm (1/8")

Connector Type

USB-C port

Mounting Type

5/8" - 27 thread mount

Housing

Diecast aluminum

Net Weight

567 g (1.25 lbs)

Dimensions

(when mic and yoke assembly are 90 degrees to one another, measured from surface to top of mic)

164 mm H x 207 mm L x 90 mm D

Cable

Includes one (1) 3m USB-C to USB-C cable

Software Compatibility

MOTIV Mix Desktop App, MOTIV Audio iOS and Android Apps

Bit Depth	Sampling Rate
24	48 kHz
16*	44.1 kHz*

* iOS only

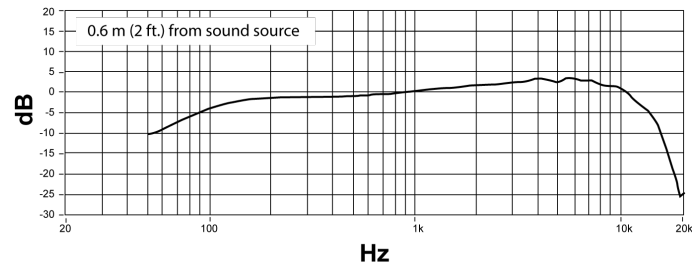

Typical Frequency Response

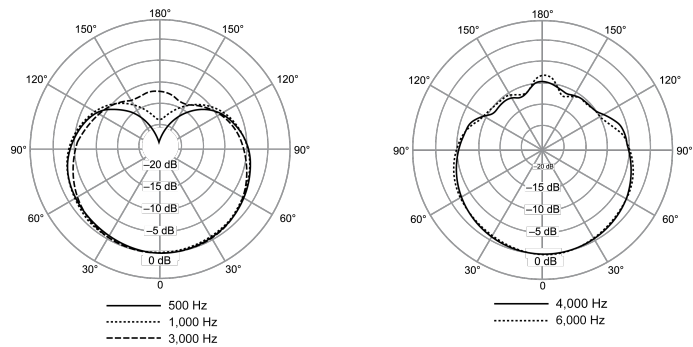

Typical Polar Pattern

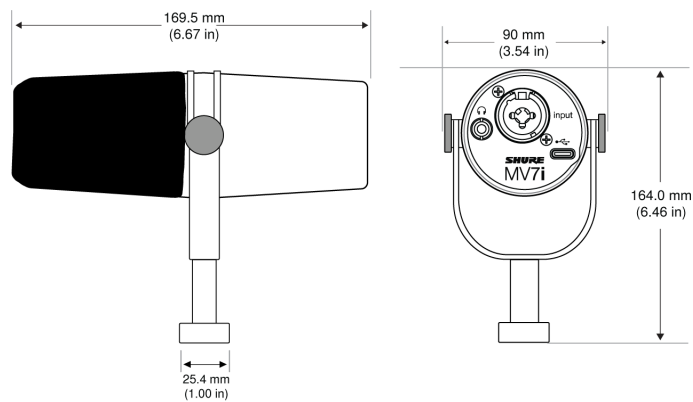

Overall Dimensions

MV7i Yoke Assembly

The MV7i yoke allows a podcaster to be flexible with mic placement. Loosen the yoke knobs and you can adjust the microphone in a variety of angles. If the microphone becomes detached from the yoke, these are the steps to put it together in the correct order to ensure that your microphone is secure. Each side uses one thin gray spring washer, one shiny silver brass washer, two black plastic washers and the yoke and threaded yoke knob.

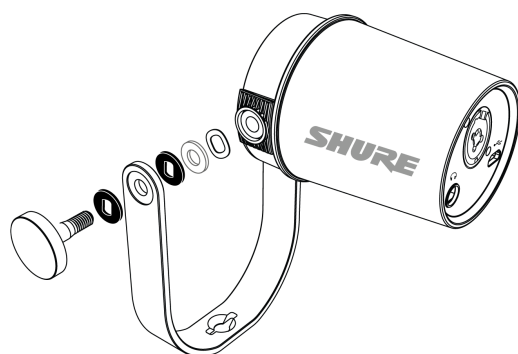

1. Start with the threaded knob flat side down on your tabletop.



2. **Stack the washers on the threaded knob.**
 - Place a black plastic washer on the knob.
 - Place one side of the yoke on next.
 - Then put the second black plastic washer on.
 - Place the flat silver washer and then the thin spring washer on the threaded knob.
3. **Using your finger to hold the screw assembly in place, slide the MV7i onto the threaded screw and turn the knob to keep washers in place.**

Note: Be sure to keep this side on but loose so that you have room to easily move the yoke and assemble the washers on the opposite side.

4. **On the opposite yoke arm, place the washers into the side of the MV7i in reverse order.** Thin spring washer > Flat silver washer > Black plastic washer > Yoke arm
5. **The yoke arm needs to be placed directly onto the stack of washers. To ensure that the washers are aligned, put a pen through the yoke and washers to make sure that everything is properly centered. Leave pen in place.**
6. **Place the second black plastic washer onto the remaining threaded knob.**
7. **Remove the pen. Insert the threaded knob and black plastic washer into the stacked washers and tighten both sides to ensure that your microphone is stable.**

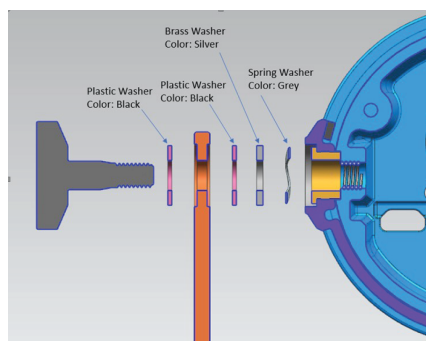

Accessories

Furnished Accessories

3 meter USB-C to USB-C Cable	95C52640
Black Foam Windscreen	AMV7+K
5/8" to 3/8" Thread Adapter	31A1856

Replacement Parts

Black Windscreen	AMV7+K
Black Replacement Grille	95B41550

Certifications

Information to the user

This equipment has been tested and found to comply with the limits for a Class B digital device, pursuant to part 15 of the FCC Rules. This equipment generates, uses, and can radiate radio frequency energy and, if not installed and used in accordance with the manufacturer's instruction manual, may cause interference with radio and television reception.

Notice: The FCC regulations provide that changes or modifications not expressly approved by Shure Incorporated could void your authority to operate this equipment.

These limits are designed to provide reasonable protection against harmful interference in a residential installation. This equipment generates, uses, and can radiate radio frequency energy and, if not installed and used in accordance with the instructions, may cause harmful interference to radio communications. However, there is no guarantee that interference will not occur in a particular installation. If this equipment does cause harmful interference to radio or television reception, which can be determined by turning the equipment off and on, the user is encouraged to try to correct the interference by one or more of the following measures:

- Reorient or relocate the receiving antenna.
- Increase the separation between the equipment and the receiver.
- Connect the equipment to an outlet on a circuit different from that to which the receiver is connected.
- Consult the dealer or an experienced radio/TV technician for help.

This device complies with part 15 of the FCC Rules. Operation is subject to the following two conditions:

1. This device may not cause harmful interference.
2. This device must accept any interference received, including interference that may cause undesired operation.

This Class B digital apparatus complies with Canadian ICES-003. Cet appareil numérique de la classe B est conforme à la norme NMB-003 du Canada.

For information regarding responsible party and other matters relating to FCC compliance, please contact Shure Incorporated, 5800 W. Touhy Avenue, Niles, Illinois 60714-4608 U.S.A. [shure.com/contact](https://www.shure.com/contact)

Industry Canada ICES-003 Compliance Label: CAN ICES-3 (B)/NMB-3(B)

Canada, ISED Notice

Notice: The Industry Canada regulations provide that changes or modifications not expressly approved by Shure Inc. could void your authority to operate this equipment.

This microphone for use with any microphone stand with a 5/8" threaded adapter.

Note: Testing is based on the use of supplied and recommended cable types. The use of other than shielded (screened) cable types may degrade EMC performance.

CE Notice

Hereby, Shure Incorporated declares that this product with CE Marking has been determined to be in compliance with European Union requirements.

The full text of the EU declaration of conformity is available at the following site: <https://www.shure.com/en-EU/support/declarations-of-conformity>.

UKCA Notice

Hereby, Shure Incorporated declares that this product with UKCA Marking has been determined to be in compliance with UK-CA requirements.

The full text of the UK declaration of conformity is available at the following site: <https://www.shure.com/en-GB/support/declarations-of-conformity>.

This product meets the Essential Requirements of all relevant European directives and is eligible for CE marking.

Made for iPad (5th generation), iPad (6th generation), iPad (7th generation), iPad (8th generation), iPad Air 2, iPad Air 3, iPad Mini 4, iPad Mini 5, iPad Pro 9.7-inch (1st generation), iPad Pro (12.9-inch) 1st generation, iPad Pro 10.5-inch 2017 (2nd generation), iPad Pro 12.9-inch 2017 (2nd generation), iPhone 6s, iPhone 6s Plus, iPhone SE, iPhone 7, iPhone 7 Plus, iPhone 8, iPhone 8 Plus, iPhone X, iPhone Xs, iPhone Xs Max, iPhone XR, iPhone 11, iPhone 11 Pro, iPhone 11 Pro Max, iPhone 12, iPhone 12 Mini, iPhone 12 Pro, iPhone 12 Pro Max, iPhone SE 2, iPod Touch (7th generation).

iPad, iPhone, iPod and iPod touch are trademarks of Apple Inc., registered in the U.S. and other countries. iPad Air, iPad mini, and Lightning are trademarks of Apple Inc. The trademark "iPhone" is used in Japan with a license from Aiphone K.K.

Android Compatibility

This equipment is compatible with Android devices that support USB Audio Class 2.0 and USB-C connectivity. Not all Android devices are compatible. Android is a trademark of Google Inc.

Recycling Information

Please consider the environment, electric products and packaging are part of regional recycling schemes and do not belong to regular household waste.



	적합등록번호 (Certification No.) : R-R-SHU-MV7I
	기자재명칭 (Product Type) : Wired Microphone
	모델명 (Model Name) : MV7i
	상호/제조사(Registrant/Manufacturer) : Shure Incorporated
	제조국가 (COO) : China
	제조일자 (Date of manufacture) : 별도표기
수입업체 (Importer) : 삼아사운드 유한회사 (SAMASOUND INC.)	

Environmental Regulatory Information

Waste Electrical and Electronic Equipment (WEEE) Directive



In the European Union and the United Kingdom, this label indicates that this product should not be disposed of with household waste. It should be deposited at an appropriate facility to enable recovery and recycling.

Registration, Evaluation, Authorization of Chemicals (REACH) Directive

REACH (Registration, Evaluation, Authorization of Chemicals) is the European Union (EU) and the United Kingdom (UK) chemical substances regulatory framework. Information on substances of very high concern contained in Shure products in a concentration above 0.1% weight over weight (w/w) is available upon request.