

SERVICE MANUAL

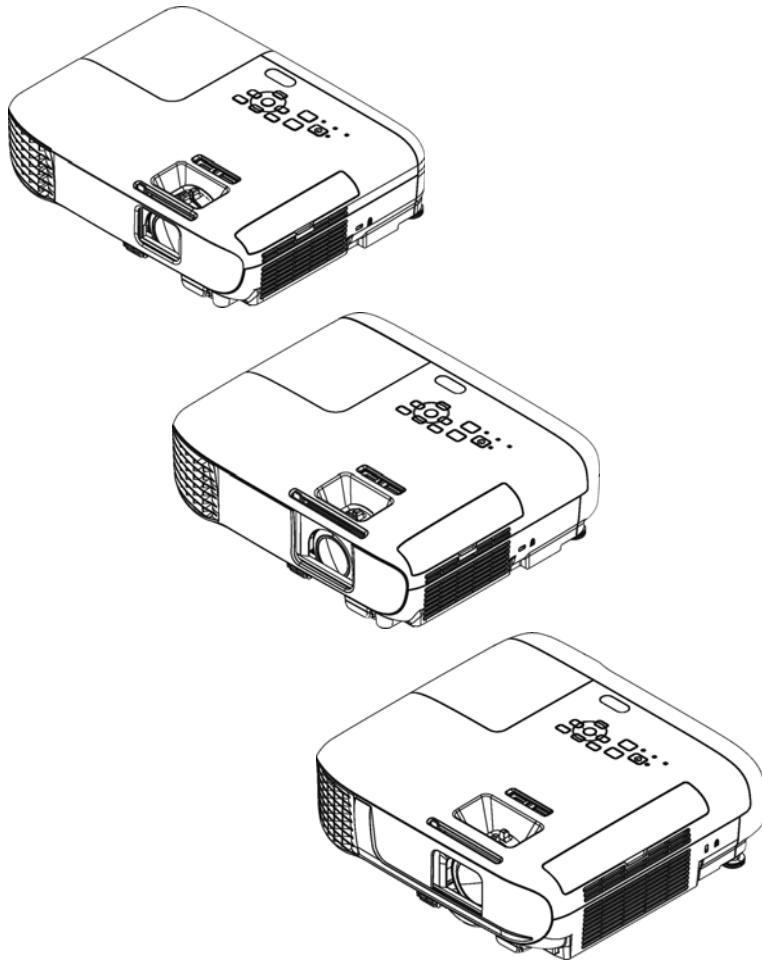

Business Projector

**EB-E01/X06/W06/E10
EB-X51/W51/E20/W52**

 **WARNING**

Electric shock may result if you operate carelessly because there is electric charge remaining to reduce power consumption in the Power Supply.
Make sure to follow the procedure below.

" 3.3.14 PS Ballast Assy (p122) "

EPSON
EXCEED YOUR VISION

INTERNAL USE ONLY

NOTICE

- All rights reserved. No part of this manual may be reproduced, stored in retrieval system, or transmitted in any form or by any means, electronic, mechanical, photocopying, recording, or otherwise, without prior written permission of SEIKO EPSON CORPORATION.
- The contents of this manual should be handled with sufficient consideration for confidentiality reasons.
- After publication of this manual, the parts and mechanism may be subject to change for improvement of their performance. Therefore, note that the descriptions given in this manual may not coincide with the actual machine.
- Other company or product names used herein are for identification purpose only and may be trademarks or registered trademarks of their respective owners. EPSON disclaims any and all rights in those marks.

EPSON is a registered trademark of Seiko Epson Corporation.

Other product names used herein are for identification purpose only and may be trademarks or registered trademarks of their respective owners.

Copyright © 2020 SEIKO EPSON CORPORATION.

About This Manual

This manual describes basic functions, theory of electrical and mechanical operations, maintenance and repair procedures of the product. The instructions and procedures included herein are intended for the experienced repair technicians, and attention should be given to the precautions on the preceding page.

CHAPTER 1. PRODUCT DESCRIPTIONS

Provides a general overview of the features and specifications of the product.

CHAPTER 2. TROUBLESHOOTING

Explains basic confirmation items for identifying the location of obstacle based on defects and abnormal symptoms.

CHAPTER 3. DISASSEMBLY / ASSEMBLY

Describes the step-by-step procedures for disassembling and assembling the main component units and parts of the product.

CHAPTER 4. APPENDIX









Provides preventive maintenance procedures for servicing the product.

IMPORTANT PRECAUTIONS IN SAFETY AND MAINTENANCE PERFORMANCE

Here describes the important points to keep in mind in repair and maintenance performance.







SYMBOLS







To prevent injury to the repair technicians and to protect the devices, the categorized safety instructions are provided in this manual with the symbols below. Be sure to read and understand their meanings before proceeding to the next section.







Category	Symbol	Meaning
Danger		Indicates an extremely hazardous operation which, if ignored or operated incorrectly, could result in serious or fatal personal injury.
Warning		Indicates a potentially hazardous operation which, if ignored or operated incorrectly, could result in serious or fatal personal injury.
Caution		Indicates a potentially hazardous operation which, if ignored or operated incorrectly, could result in minor injury or damage to equipment.
Prohibited Matter		Indicates a prohibited action or operation in repair and maintenance performance.
Instruction		Indicates a compulsory action or operation that must be carried out in repair and/or maintenance.
Reassembly		Indicates a compulsory action or operation for reassembly of disassembled parts that must be carried out in repair and/or maintenance.
Setting/ Maintenance		Indicates a compulsory action or operation for settings or maintenance that must be carried out in repair and/or maintenance.
Point		Indicates reference information in repair and/or maintenance.



SAFETY INSTRUCTIONS

The precautionary measures itemized below should be fully understood when performing repair and maintenance procedures.

	
	<p>When disassembling/assembling, be sure to turn off the power switch and pull out the power cable from the projector beforehand.</p>
	<p>Be extremely careful about the current-carrying part during a test operation, signal measurement or any other situations that is necessary to perform the repair/maintenance work with the power turned on and the cover removed. Take off the things made of metal (such as a wrist watch, cuff buttons, rings, tie pin, etc.) which may come in contact with the parts inside the projector.</p>
	<p>Do not touch the lamp assy. or the parts around it. They are extremely hot even after completing the cooling down operation, and may cause a burn injury. Therefore, leave the unit until it becomes cool enough before performing maintenance work.</p>
	<p>Never let the safety devices mounted in this product inactivated, modify the safety devices or replace them with the ones that are not designated for any reason whatsoever. (Such actions may endanger the projector's safety operation and may result in a fire or serious injury.)</p>
	<p>Never modify the product for any reason whatsoever. (Except for a case that is under the instructions to do so. In such a case, understand the instructions thoroughly in advance and perform modification appropriately.)</p>

	<p>Never peer through the projection lens during repair/maintenance work when the power is on. (Such an action may cause a visual disability because of a very strong light emission.)</p>
	<p>Never use a deformed plug or a damaged power cable to this product. If any deformations or damages are found on the power cable or plug section, replace it with a new specified power cable.</p>
	<p>Never use the air blowers that contain flammable gas in repair/maintenance work.</p>
	<p>Never use or replace with any service parts that is not specified by EPSON.</p>
	<p>Do not disassemble any parts or components not specified in this manual.</p>
	<p>Do not apply any shock or vibration. (Otherwise, misalignment of the optical parts inside the engine may cause irregular reflection of the light and may result in burn (smoke) or damage to the internal parts.)</p>
	<p>Do not touch any parts such as inorganic polarizers that are instructed not to.</p>

 CAUTION	
	Be sure to perform the repair/maintenance work on the even and stable work bench to prevent the product from dropping down or mal-operation due to the improper setting of the product.
	Be sure to take off the metal products such as wrist watch, cuff buttons, rings, tie pin etc. in repair and/or maintenance to avoid unsafe situations.
	Be sure to wear the gloves during the repair/maintenance work to avoid injuries by the parts with sharp edges such as metal plate or the like.
	To protect sensitive circuitry, follow the instructions below. <ul style="list-style-type: none"> ■ When disassembling or reassembling, be sure to wear static discharge equipment such as an anti-static wrist strap and a mat. ■ When replacing the circuit component such as a board or the optical engine, be sure to contact the anti-static case containing the new one to the metal part of this product before taking it out.
	When performing the repair/maintenance work, be sure to use the specified tools and follow the instructions that are specified in the documents (service manual etc.) concerning to this product.
	When carrying out the test operation, do not block the intake and exhaust ducts. (Such an action raises the internal temperature and may cause a fire or a damages to the internal parts of this product.)

	Be careful not to drop a metal part such as a screw, a washer, or a clip into the inside of the product. If such cases should occur accidentally, never turn on the power supply until all the dropped parts are found and removed.
	After reassembling the product, check the followings before turning the power on. <ul style="list-style-type: none"> ■ All the parts and screws are installed and secured to the proper positions. ■ No cables are caught in the metal frames.
	If there are accumulated dust or foreign objects inside the product, make sure to remove them before disassembling/reassembling the product.

OTHER CAUTION

Since the lamp of this product contains mercury, be sure to dispose the used lamp pursuant to the government's law and regulations.

REVISION HISTORY

After first release of this manual, the parts and mechanism may be subject to change for improvement of their performance and the manual may be revised. Be sure to always keep this manual up to date.

Revision	Date	Page of change	Detail of change
A	2020.1.21	all	First Release

Contents

Chapter 1 Product Description

1.1 Product Description	11
1.2 Specifications	12
1.3 Dimensions	20
1.4 Ceiling Mount.....	24

Chapter 2 Troubleshooting

2.1 Required Tools	33
2.2 Troubleshooting Procedure	34
2.3 Exterior Check.....	36
2.4 Troubleshooting from the Device Names.....	37
2.5 Error Indication and Problem diagnosis	39
2.5.1 Troubleshooting based on LED Indications	39
2.5.2 Troubleshooting by Error Names	43
2.5.3 Troubleshooting without Error Indications	47
2.5.4 Troubleshooting on image abnormality	51
2.5.5 Cable connection on the MA Board and error symptoms	53
2.6 Parts Layout Diagrams	58

Chapter 3 Disassembly and Assembly

3.1 Precautions	64
3.1.1 General Cautions in operation	64
3.1.2 Precautions.....	65
3.1.3 Workflow.....	65
3.1.4 Tools	66
3.1.4.1 Tool List.....	66
3.1.4.2 Recommended Tool List.....	66
3.1.5 How to unlock connectors for FFC/FPC	67
3.2 Flowchart.....	70
3.2.1 Standard operation time.....	70
3.3 Disassembly and Assembly.....	73
3.3.1 Air Filter	73

3.3.2 Lamp.....	74
3.3.3 Front Foot	75
3.3.4 Rear Foot	76
3.3.5 Rear Case.....	77
3.3.6 Upper Case (Assy).....	80
3.3.6.1 SW Board.....	84
3.3.6.2 H Key Assy/Upper Case	86
3.3.6.3 Shutter.....	87
3.3.6.4 Upper Case.....	89
3.3.7 WFD Board.....	94
3.3.8 P3dash Module	96
3.3.9 RTC Board.....	97
3.3.10 MA Board Assy	100
3.3.10.1 Speaker 16W.....	105
3.3.10.2 IF Board	106
3.3.11 Optical Engine (Assy)	113
3.3.11.1 Auto Iris Assy	115
3.3.11.2 Focus Ring/Zoom Ring.....	116
3.3.12 EX Duct (Assy)	118
3.3.12.1 EX Fan/TH Board.....	119
3.3.13 Lamp Fan (Assy)	120
3.3.13.1 Lamp Fan/Speaker 5W	121
3.3.14 PS Ballast Assy.....	122
3.3.15 P4combo Module.....	128
3.3.16 INT Duct (Assy).....	129
3.3.16.1 IR Board.....	131
3.3.16.2 INT Fan/TH Board.....	132
3.3.17 Filter Boards	135
3.3.18 Lower Case/IR Board	136
3.4 Shortest removal procedures of identified failed parts.....	137
3.4.1 Speaker	137
3.4.2 IR Board	138
3.4.3 LMP Thermistor	139
3.4.4 EX Fan.....	140
3.5 Individual Function Check After Repair	141
3.5.1 Safety Check after Servicing	142

3.5.1.1	Insulation resistance test	143	4.1.2.2	Confirmation method which connects PC with projector.....	184
3.5.1.2	Ground continuity check.....	144	4.1.2.3	Confirmation method using a USB memory	188
3.5.1.3	Illumination check	144	4.1.3	Initializing (Resetting).....	190
3.5.2	Initialization.....	145			
3.5.3	Operation Check for control panel	145			
3.5.4	Operation Check for remote controller.....	145			
3.5.5	Operation Check for video input/output.....	146			
3.5.6	Operation Check for audio input/output.....	146			
3.5.7	Communication Check	147			
3.5.8	Internal Cable Connection Check.....	147			
3.5.9	The service tools and the adjustment tasks list which required before and after parts replacement.....	148			
3.5.10	Service tool list	150			
3.6	Writing the DR Data.....	152			
3.6.1	Overview.....	152			
3.6.2	Preparation.....	153			
3.6.3	Operating Procedure	153			
3.6.3.1	Workflow	153			
3.6.3.2	Check in advance	154			
3.6.3.3	Replacing the Optical Engine	156			
3.6.3.4	Replacing the MA Board	158			
3.7	G Sensor Calibration	161			
3.7.1	Overview.....	161			
3.7.2	Preparation.....	161			
3.7.3	Procedure	161			
3.8	LCD Alignment.....	162			
3.8.1	Overview.....	162			
3.8.2	Pixel color shift confirmation method	162			
3.8.3	LCD alignment activation method.....	162			
3.8.3.1	Adjustment method.....	164			
3.9	Part Names List	166			

Chapter 4 Appendix

4.1	AS (After Service) Menu.....	171
4.1.1	How To Display the AS (After Service) Menu	171
4.1.1.1	How to enter the AS menu.....	171
4.1.1.2	Menu Contents.....	171
4.1.2	Confirmation method using IPS tool.....	184
4.1.2.1	Preparation	184

CHAPTER

1

PRODUCT DESCRIPTION

1.1 Product Description

This projector comes with this special features. Refer to these sections for more details.

- Quick and Easy Setup
 - Direct Power On feature to turn on the projector as soon as you plug it in.
 - Auto Power On feature to turn on the projector when the projector detects an image signal from the port you specified as the Auto Power On source.
 - Home screen feature to easily select an input source and useful functions.
 - Automatic vertical keystone correction always displays a rectangular screen (Auto V-Keystone).
 - Horizontal correction slider to quickly correct the lateral strain of the projected image. Sliding horizontal correction is convenient when the projector cannot be parallel to the screen. (Except EB-E01/E10)
- Easy Wireless Projection (EB-FH52/992F EH-TW750 only)
 - Screen Mirroring allows a wireless connection between the projector and a mobile device compatible with Miracast.
 - Epson iProjection (Windows/Mac) to project up to four images at the same time by splitting the projected screen. You can project images from computers on the network, or from smartphones or tablet devices.
- Flexible Connectivity
 - This projector can be connected to computers, video equipment, smartphones, tablet terminals, and other devices.
- Slide Show Function (except EB-E01/E10)
 - The images in a USB storage can be projected without using a computer
 - Equipped with USB terminal (Type A)

- Enhanced security functions
 - Operation button lock function
 - Security cable installation
 - Remote password
- Sliding Lens Cover for Easy Projection And Storage (other than EB-E01/E10)
- No cool-down period is needed.
- Auto Iris

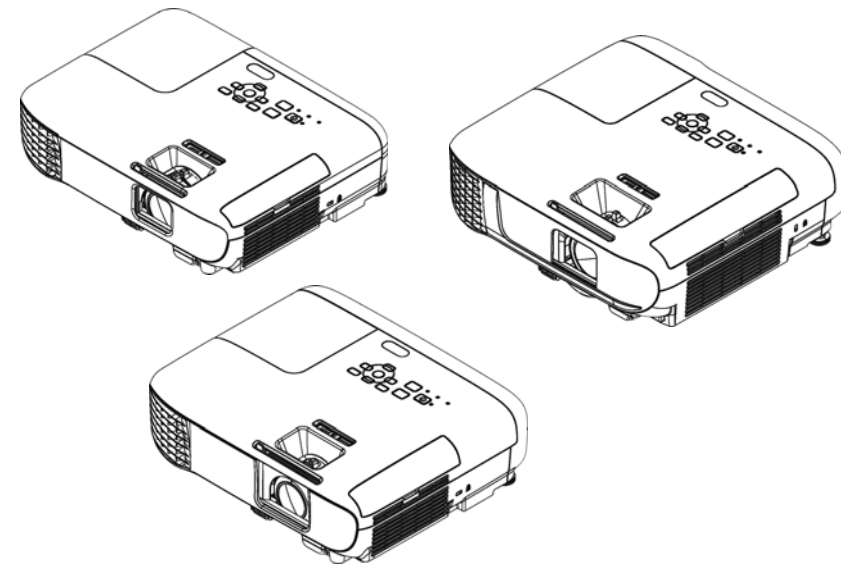

External View

1.2 Specifications

□ EB-E01/X06/W06/E10/X51/W51/W52

Model		EB-E01	EB-X06	EB-W06	EB-E10	EB-X51	EB-W51	EB-W52		
Item										
Specific ation of main part	LCD	Size	0.55 inch (C2fine)	0.55 inch (C2fine)	0.59 inch (C2fine)	0.55 inch (C2fine)	0.55 inch (C2fine)	0.59 inch (C2fine)	0.59 inch (C2fine)	
		Pixel number	786,432 pixels (1024 x 768) x 3	786,432 pixels (1024 x 768) x 3	1,024,000 pixels (1280 x 800) x 3	786,432 pixels (1024 x 768) x 3	786,432 pixels (1024 x 768) x 3	1,024,000 pixels (1280 x 800) x 3	1,024,000 pixels (1280 x 800) x 3	
		Native resolution	XGA	XGA	WXGA	XGA	XGA	WXGA	WXGA	
		Aspect ratio	4:3	4:3	16:10	4:3	4:3	16:10	16:10	
	Projection Lens	Focus	Type	Manual						
		Zoom	Type	Digital	Manual	Manual	Digital	Manual	Manual	Manual
			Ratio	1-1.35	1-1.2	1-1.2	1-1.35	1-1.2	1-1.2	1-1.2
	Lamp	Type		UHE						
		Power consumption		210W						
		Life	Normal	6,000 hours						
			Eco	12,000 hours						
	Brightn ess	Normal mode	Color mode: Dynamic, Zoom: Wide	3,300lm	3,600lm	3,700lm	3,600lm	3,800lm	4,000lm	4,000lm
Eco mode		Color mode: Dynamic, Zoom: Wide	2,200lm	2,400lm	2,400lm	2,200lm	2,500lm	2,600lm	2,600lm	
Sound output			Monaural: 2W x 1							
I/O	Video input	Analog	D-sub 15pin	1 (Blue molding)						
			RCA	—	1 (Yellow)	1 (Yellow)	—	1 (Yellow)	1 (Yellow)	1 (Yellow)
		Digital	HDMI	1						
	Video output	Analog	D-sub 15pin	—						
	Audio	Input	RCA (L/R)	—	1	1	—	1	1	1
			Stereo mini	—						
		Output	Stereo mini	—						
	Mic	Input	Stereo mini	—						

Model				EB-E01	EB-X06	EB-W06	EB-E10	EB-X51	EB-W51	EB-W52	
Item											
I/O	USB	Type A		—	1	1	—	1	1	1	
		Type B		1							
	RS232C	D-sub 9pin		—							
	Network	Cable LAN	RJ45		—						
Wireless LAN		USB Type A (ELPAP11)		—	Optional	Optional	—	Optional	Optional	—	
I/O	Wireless connection	Screen Mirroring		—							
Operating Temperature	Temperature		5°C to 40°C [41°F to 104°F] (Elevation 0 to 2,286 m) 5°C to 35°C [41°F to 95°F] (Elevation 2,287 m or more)								
	Humidity		20% - 80% humidity								
Operating Altitude	Normal		0 m to 3,048 m <0 ft to 10000 ft>								
	High altitude mode		1500 m <4921 ft> or more								
Start-up period			Less than 6 seconds								
Warm-up period			30 seconds								
Cool-down period			Instant off								
Power on was possible/impossible			100 - 240 V AC +/- 10%, 50/60 Hz								
Power consumption	100-120V Area (JAPAN, USA, etc.)	Lamp	ON (Normal)	345W							
			ON (Eco)	235W							
		Standby (Network On)		2.0W							
		Energy Saving		0.3W							
	220-240V Area (Europe, etc.)	Lamp	ON (Normal)	327W							
			ON (Eco)	235W							225W
		Standby (Network On)		2.0W							
		Energy Saving		0.3W							
Rated Voltage & Current (Except Japan)			100 - 240 V AC 50/60 Hz 3.5A - 1.6A								

Model			EB-E01	EB-X06	EB-W06	EB-E10	EB-X51	EB-W51	EB-W52
Item									
Size	Excluding feet	Unit: mm	302(W) x 77 (H) x 234 (D)	302(W) x 77 (H) x 234 (D)	302(W) x 77 (H) x 234 (D)	302(W) x 77 (H) x 234 (D)	302(W) x 77 (H) x 234 (D)	302(W) x 77 (H) x 234 (D)	302 (W) x 87 (H) x 234 (D)
	Maximum Dimension		302(W) x 82 (H) x 237 (D)	302(W) x 82 (H) x 237 (D)	302(W) x 82 (H) x 237 (D)	302(W) x 82 (H) x 237 (D)	302(W) x 82 (H) x 237 (D)	302(W) x 82 (H) x 237 (D)	302(W) x 82 (H) x 237 (D)
Weight			Approx. 5.29 lbs./ 2.4 kg	Approx. 5.51 lbs./ 2.5 kg	Approx. 5.51 lbs./ 2.5 kg	Approx. 5.29 lbs./ 2.4 kg	Approx. 5.51 lbs./ 2.5 kg	Approx. 5.51 lbs./ 2.5 kg	Approx. 5.73lbs./ 2.6 kg
Fan noise	Normal mode	37 dB							
	Eco mode	28 dB							

□ EB-E20/X49/W49/972/982W/118, PL 119W

Model			EB-E20	EB-X49	EB-W49	EB-972	EB-982W	EB-118	PL 119W	
Item										
Specific ation of main part	LCD	Size	0.55 inch (C2fine)	0.55 inch (C2fine)	0.55 inch (C2fine)	0.55 inch (C2fine)	0.59 inch (C2fine)	0.55 inch (C2fine)	0.59 inch (C2fine)	
		Pixel number	786,432 pixels (1024 x 768) x 3	786,432 pixels (1024 x 768) x 3	1,024,000 pixels (1280 x 800) x 3	786,432 pixels (1024 x 768) x 3	1,024,000 pixels (1280 x 800) x 3	786,432 pixels (1024 x 768) x 3	1,024,000 pixels (1280 x 800) x 3	
		Native resolution	XGA	XGA	WXGA	XGA	WXGA	XGA	WXGA	
		Aspect ratio	4:3	4:3	16:10	4:3	16:10	4:3	16:10	
	Projection Lens	Focus	Type	Manual						
		Zoom	Type	Digital	Manual	Manual	Manual	Manual	Manual	Manual
			Ratio	1-1.35	1-1.2	1-1.2	1-1.6	1-1.6	1-1.2	1-1.2
	Lamp	Type		UHE						
		Power consumption		210W	210W	210W	230W	230W	210W	210W
		Life	Normal	6,000 hours	6,000 hours	8,000 hours	6,500 hours	6,500 hours	8,000 hours	8,000 hours
			Medium	—	—	10,000 hours	10,000 hours	10,000 hours	10,000 hours	10,000 hours
	Eco		12,000 hours	12,000 hours	17,000 hours	17,000 hours	17,000 hours	17,000 hours	17,000 hours	
	Brightn ess	Normal mode	Color mode: Dynamic, Zoom: Wide	3,400lm	3,600lm	3,800lm	4,100lm	4,200lm	3,800lm	4,000lm
Medium mode		—		—	3,700lm	3,500lm	3,600lm	3,600lm	3,700lm	
Eco mode		2,200lm		2,400lm	2,600lm	2,500lm	2,600lm	2,500lm	2,600lm	
Sound output			Monaural: 5W x 1	Monaural: 5W x 1	Monaural: 5W x 1	Monaural: 16W x 1	Monaural: 16W x 1	Monaural: 16W x 1	Monaural: 16W x 1	

Model				EB-E20	EB-X49	EB-W49	EB-972	EB-982W	EB-118	PL 119W
Item										
I/O	Video input	Analog	D-sub 15pin	2 (Blue molding)						
			RCA	1 (Yellow)						
	Digital	HDMI	1	1	2	2	2	2	2	
	Video output	Analog	D-sub 15pin	1						
	Audio	Input	RCA (L/R)	1						
			Stereo mini	2						
	Output	Stereo mini	1	1	1	1	1	1	2	
	Mic	Input	Stereo mini	—	—	—	1	1	1	1
I/O	USB	Type A		—	1	1	1	1	1	1
		Type B		1						
	RS232C	D-sub 9pin		1 (for servicing only)						
	Network	Cable LAN	RJ45	—	1	1	1	1	1	1
Wireless LAN		USB TypeA (ELPAP11)	—	1	1	Optional	Optional	Optional	1	
I/O	Wireless connection	Screen Mirroring		—						
Operating Temperature	Temperature		5°C to 40°C [41°F to 104°F] (Elevation 0 to 2,286 m) 5°C to 35°C [41°F to 95°F] (Elevation 2,287 m or more)							
	Humidity		20% - 80% humidity							
Operating Altitude	Normal		0 m to 3,048 m <0 ft to 10000 ft>							
	High altitude mode		1500 m <4921 ft> or more							
Start-up period				Less than 6 seconds						
Warm-up period				30 seconds						
Cool-down period				Instant off						
Power on was possible/impossible				100 - 240 V AC +/- 10%, 50/60 Hz						

Model			EB-E20	EB-X49	EB-W49	EB-972	EB-982W	EB-118	PL 119W	
Item										
Power consumption	100-120V Area (JAPAN, USA, etc.)	Lamp	ON (Normal)	345W						
			ON (Medium)	—	—	303W	303W	303W	303W	303W
			ON (Eco)	235W						
		Standby (Network On)		2.0W						
		Energy Saving		0.3W						
	220-240V Area (Europe, etc.)	Lamp	ON (Normal)	327W						
			ON (Medium)	—	—	290W	290W	290W	290W	290W
			ON (Eco)	225						
		Standby (Network On)		2.0W						
		Energy Saving		0.3W						
Rated Voltage & Current (Except Japan)			100 - 240 V AC 50/60 Hz 3.5A - 1.6A							
Size	Excluding feet	Unit: mm	302(W) x 87 (H) x 249 (D)	302(W) x 87 (H) x 249 (D)	302(W) x 87 (H) x 249 (D)	309 (W) x 90 (H) x 282 (D)	309 (W) x 90 (H) x 282 (D)	302 (W) x 87 (H) x 249 (D)	302(W) x 87 (H) x 249 (D)	
	Maximum Dimension		302(W) x 92 (H) x 249 (D)	302(W) x 92 (H) x 249 (D)	302(W) x 92 (H) x 249 (D)	309 (W) x 105 (H) x 293 (D)	309 (W) x 105 (H) x 293 (D)	302 (W) x 92 (H) x 260 (D)	302(W) x 92 (H) x 260 (D)	
Weight			Approx. 5.95 lbs./ 2.7 kg	Approx. 5.95 lbs./ 2.7 kg	Approx. 5.95 lbs./ 2.7 kg	Approx. 6.83 lbs./ 3.1 kg	Approx. 6.83 lbs./ 3.1 kg	Approx. 6.17 lbs./ 2.8 kg	Approx. 6.17 lbs./ 2.8 kg	
Fan noise	Normal mode		37 dB							
	Eco mode		28 dB							

□ EB-FH06/FH52/992F, EH-TW740/TW750

Model				EB-FH06	EB-FH52	EB-992F	EH-TW740	EH-TW750
Item								
Specific ation of main part	LCD	Size		0.61 inch (C2fine)				
		Pixel number		2,073,600 pixels (1920 x 1080) x 3				
		Native resolution		Full HD				
		Aspect ratio		16:9				
	Projection Lens	Focus	Type	Manual				
		Zoom	Type	Manual	Manual	Manual	Digital	Manual
			Ratio	1-1.2	1-1.6	1-1.6	1-1.35	1-1.2
	Lamp	Type		UHE				
		Power consumption		210W	230W	230W	210W	210W
		Life	Normal	6,000 hours	5,500 hours	6,500 hours	6,000 hours	6,000 hours
Medium			—	—	10,000 hours	—	—	
Eco	12,000 hours		12,000 hours	17,000 hours	12,000 hours	12,000 hours		
Brightn ess	Normal mode	Color mode: Dynamic, Zoom: Wide	3,500lm	4,000lm	4,000lm	3,300lm	3,400lm	
	Medium mode		—	—	3,400lm	—	—	
	Eco mode		2,300lm	2,400lm	2,400lm	2,200lm	2,200lm	
Sound output			Monaural: 2W x 1	Monaural: 16W x 1	Monaural: 16W x 1	Monaural: 2W x 1	Monaural: 2W x 1	
I/O	Video input	Analog	D-sub 15pin	1 (Blue molding)	1 (Blue molding)	2 (Blue molding)	—	1 (Blue molding)
			RCA	1 (Yellow)	1 (Yellow)	1 (Yellow)	—	1 (Yellow)
		Digital	HDMI	2	2	2	1	2
	Video output	Analog	D-sub 15pin	—	—	1	—	—
	Audio	Input	RCA (L/R)	1	1	1	—	1
			Stereo mini	—	—	2	—	—
		Output	Stereo mini	—	—	1	1	1
	Mic	Input	Stereo mini	—	—	1	—	—

Model				EB-FH06	EB-FH52	EB-992F	EH-TW740	EH-TW750
Item								
I/O	USB	Type A		1				
		Type B		1				
	RS232C	D-sub 9pin		—	—	1 (for servicing only)	—	—
	Network	Cable LAN	RJ45	—	—	1	—	—
Wireless LAN		USB TypeA (ELPAP10)		Optional	—	1	Optional	—
I/O	Wireless connection	Screen Mirroring		—	1	1	—	1
Operating Temperature		Temperature		5°C to 40°C [41°F to 104°F] (Elevation 0 to 2,286 m) 5°C to 35°C [41°F to 95°F] (Elevation 2,287 m or more)				
		Humidity		20% - 80% humidity				
Operating Altitude		Normal		0 m to 3,048 m <0 ft to 10000 ft>				
		High altitude mode		1500 m <4921 ft> or more				
Start-up period				Less than 6 seconds				
Warm-up period				30 seconds				
Cool-down period				Instant off				
Power on was possible/impossible				100 - 240 V AC +/- 10%, 50/60 Hz				

Model			EB-FH06	EB-FH52	EB-992F	EH-TW740	EH-TW750	
Item								
Power consumption	100-120V Area (JAPAN, USA, etc.)	Lamp	ON (Normal)	345W				
			ON (Medium)	—	—	303W	—	—
			ON (Eco)	235W				
		Standby (Network On)		2.0W				
		Energy Saving		0.3W				
	220-240V Area (Europe, etc.)	Lamp	ON (Normal)	327				
			ON (Medium)	—	—	290W	—	—
			ON (Eco)	235W	225W	225W	225W	225W
		Standby (Network On)		2.0W				
		Energy Saving		0.3W				
Rated Voltage & Current (Except Japan)			100 - 240 V AC 50/60 Hz 3.5A - 1.6A					
Size	Excluding feet	Unit: mm	302(W) x 87 (H) x 249 (D)	309(W) x 90 (H) x 282 (D)	309 (W) x 90 (H) x 282 (D)	302(W) x 87 (H) x 249 (D)	302(W) x 87 (H) x 249 (D)	
	Maximum Dimension		302(W) x 92 (H) x 252 (D)	309(W) x 105 (H) x 293 (D)	309 (W) x 105 (H) x 293 (D)	302(W) x 92 (H) x 252 (D)	302(W) x 92 (H) x 252 (D)	
Weight			Approx. 5.95 lbs./ 2.7 kg	Approx. 6.83 lbs./ 3.1 kg	Approx. 6.83 lbs./ 3.1 kg	Approx. 5.95 lbs./ 2.7 kg	Approx. 6.17 lbs./ 2.8 kg	
Fan noise	Normal mode		37 dB					
	Eco mode		28 dB					

1.3 Dimensions

□ EB-EB-E01/X06/W06/E10/X51/W51

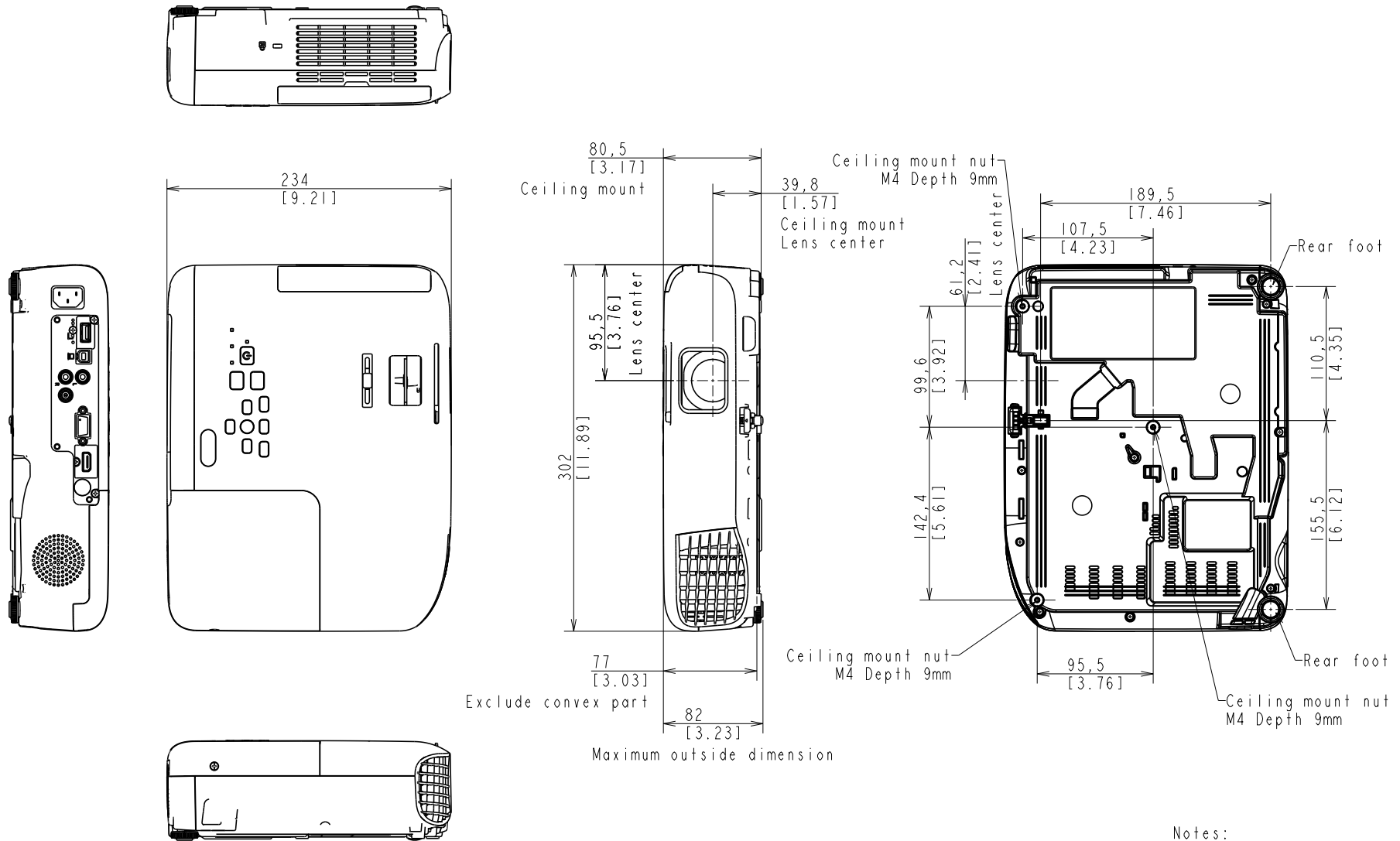

Notes:
 Unit of Dimension
 Upper: mm
 Lower: (inch)

□ EB-FH06/E20/X49/W49/118, PL 119W, EH-TW740/TW750

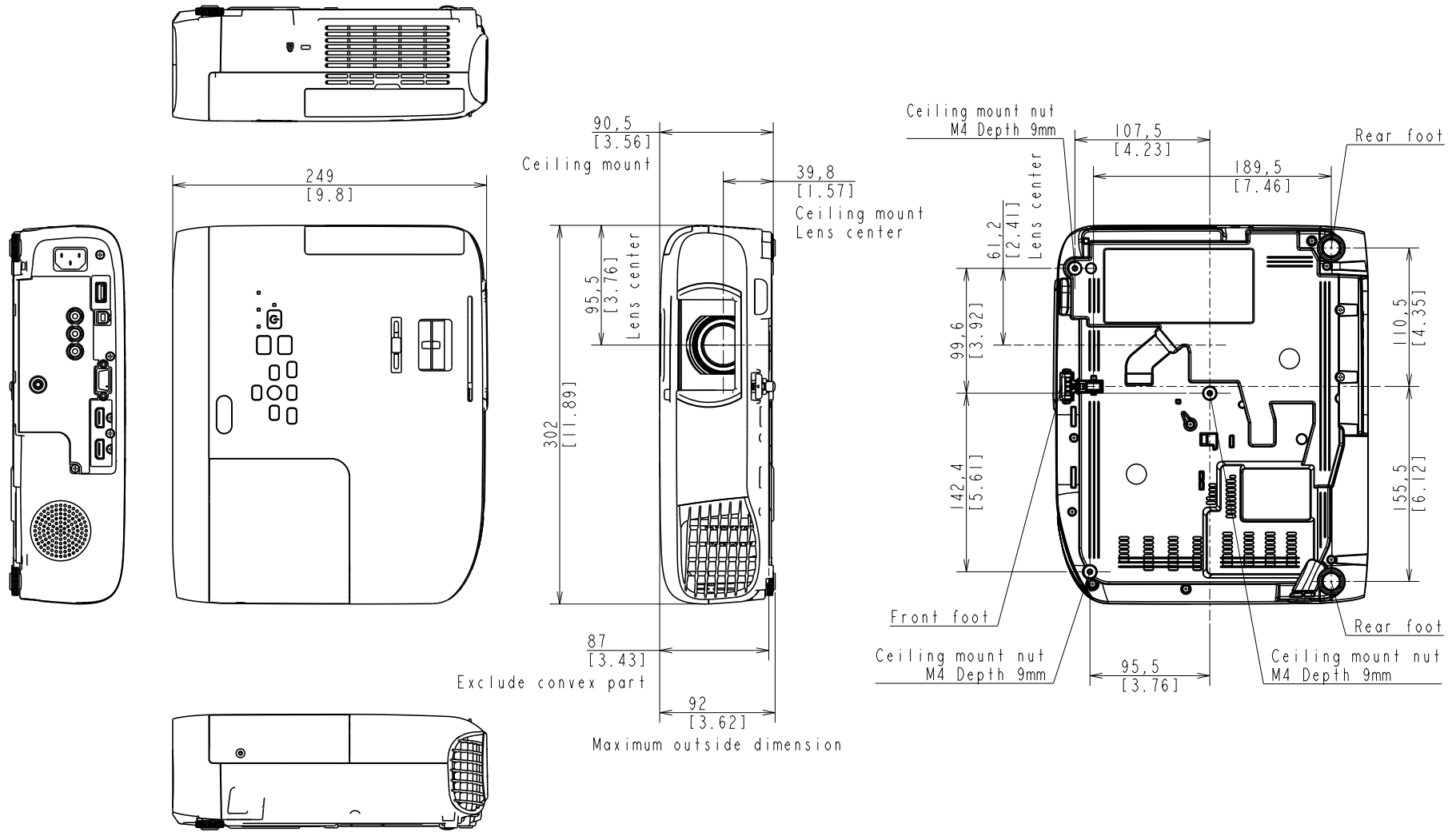

Notes:
 Unit of Dimension
 Upper: mm
 Lower: [inch]

□ EB-FH52/972/982W/992F

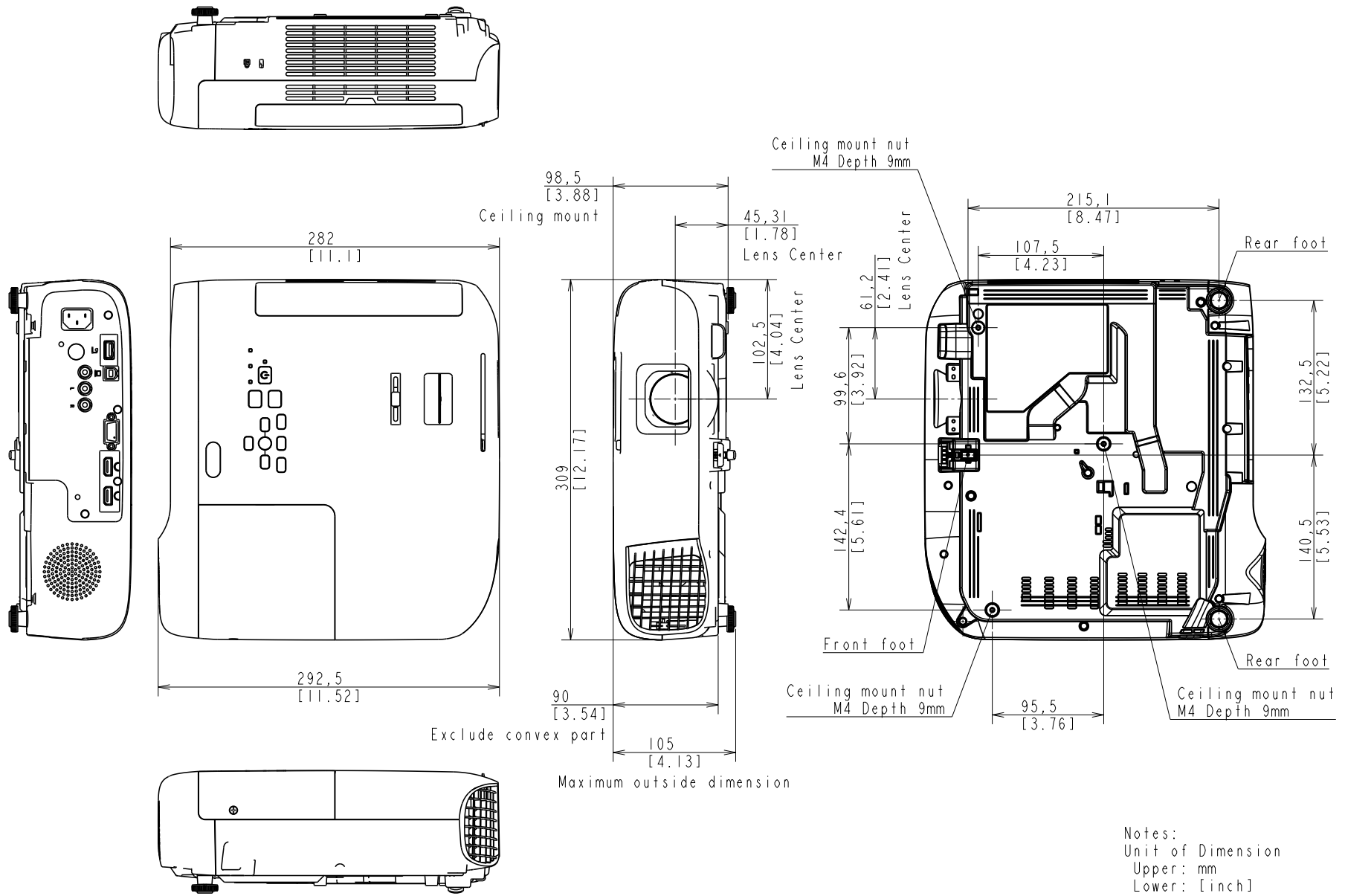

□ EB-W52

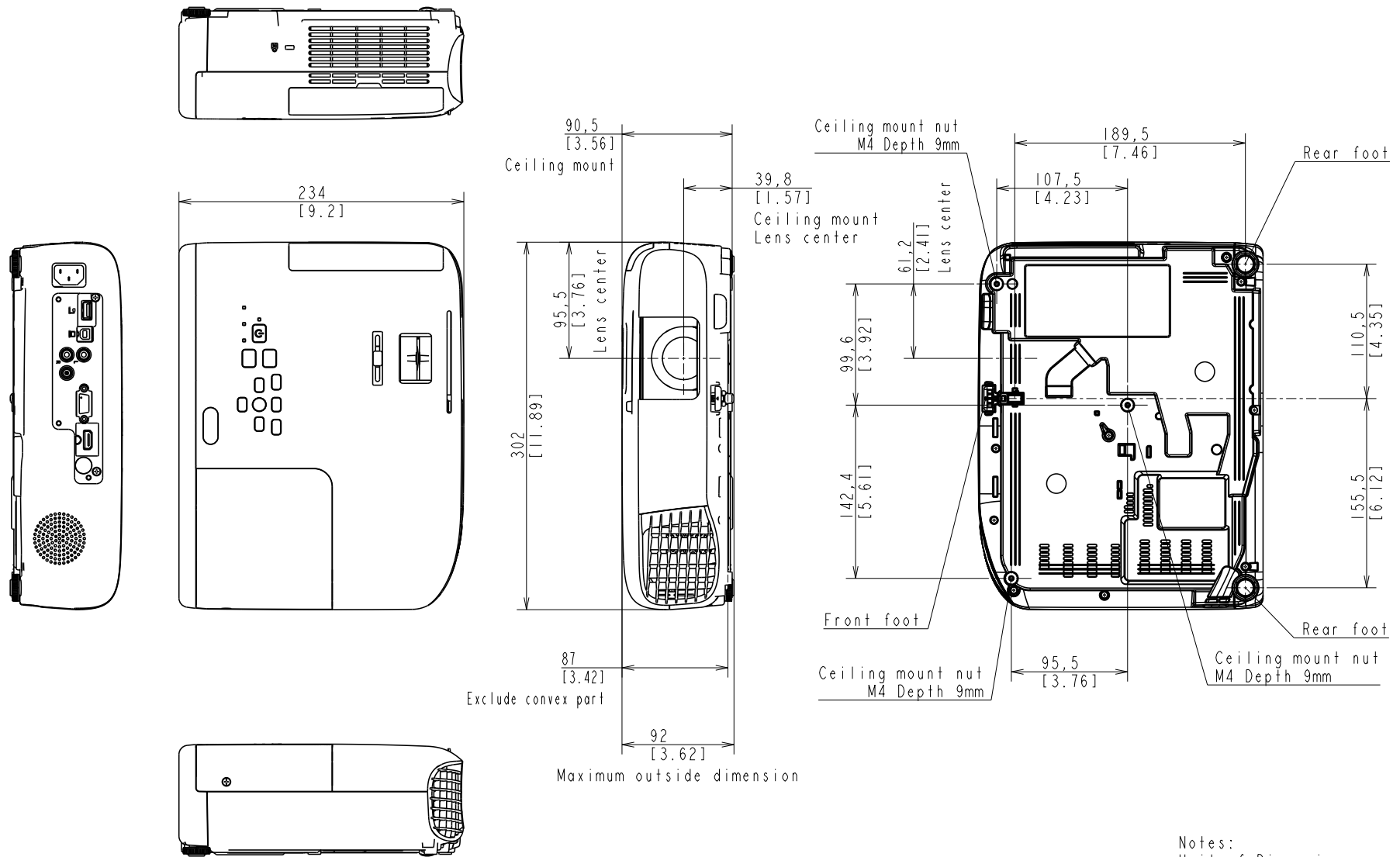

Notes:
 Unit of Dimension
 Upper: mm
 Lower: [inch]

1.4 Ceiling Mount

□ EB-E01/X06/W06/E10/X51/W51 (ELPMB23)

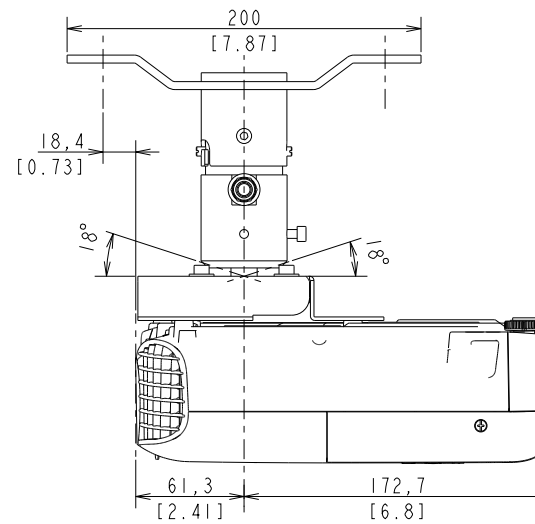
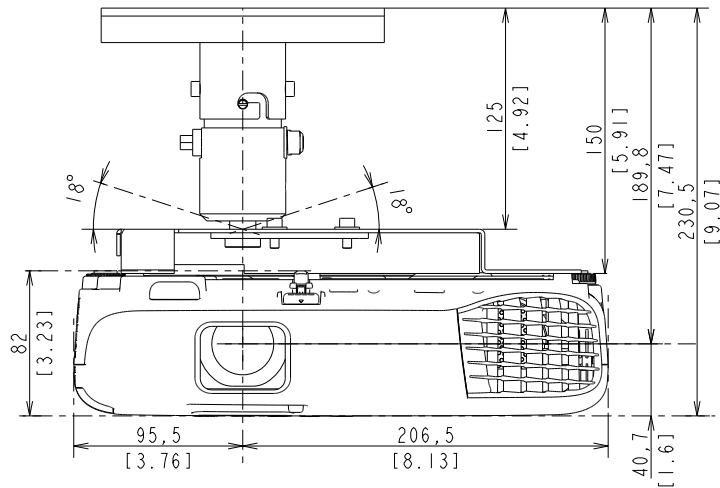
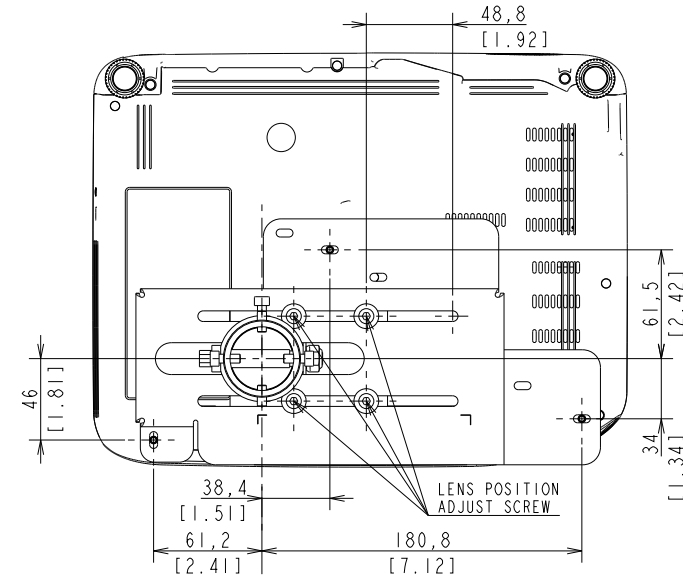
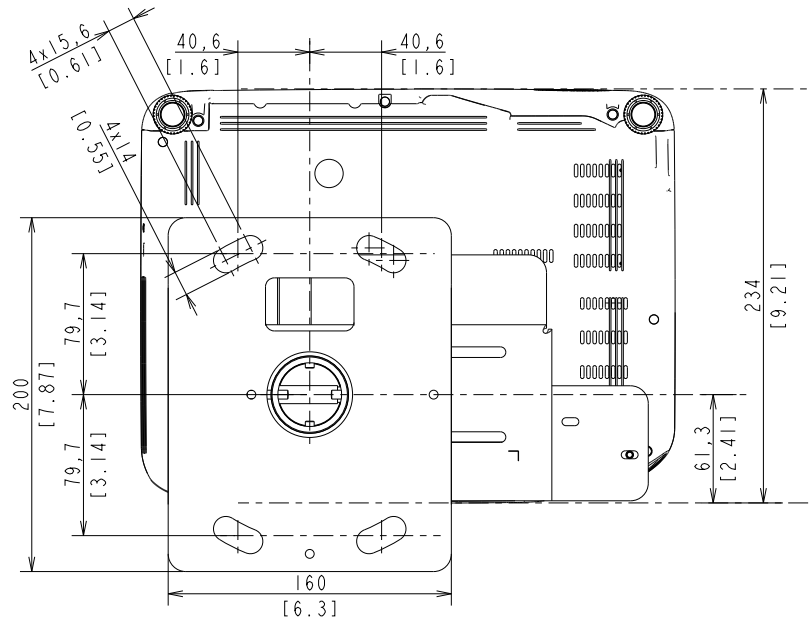

(Note)
Unit of dimension
Upper: mm
Lower: inch

□ EB-E01/X06/W06/E10/X51/W51 (ELPMB23 + ELPFP13/ELPFP14)

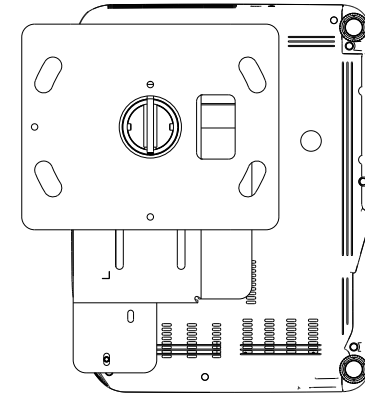
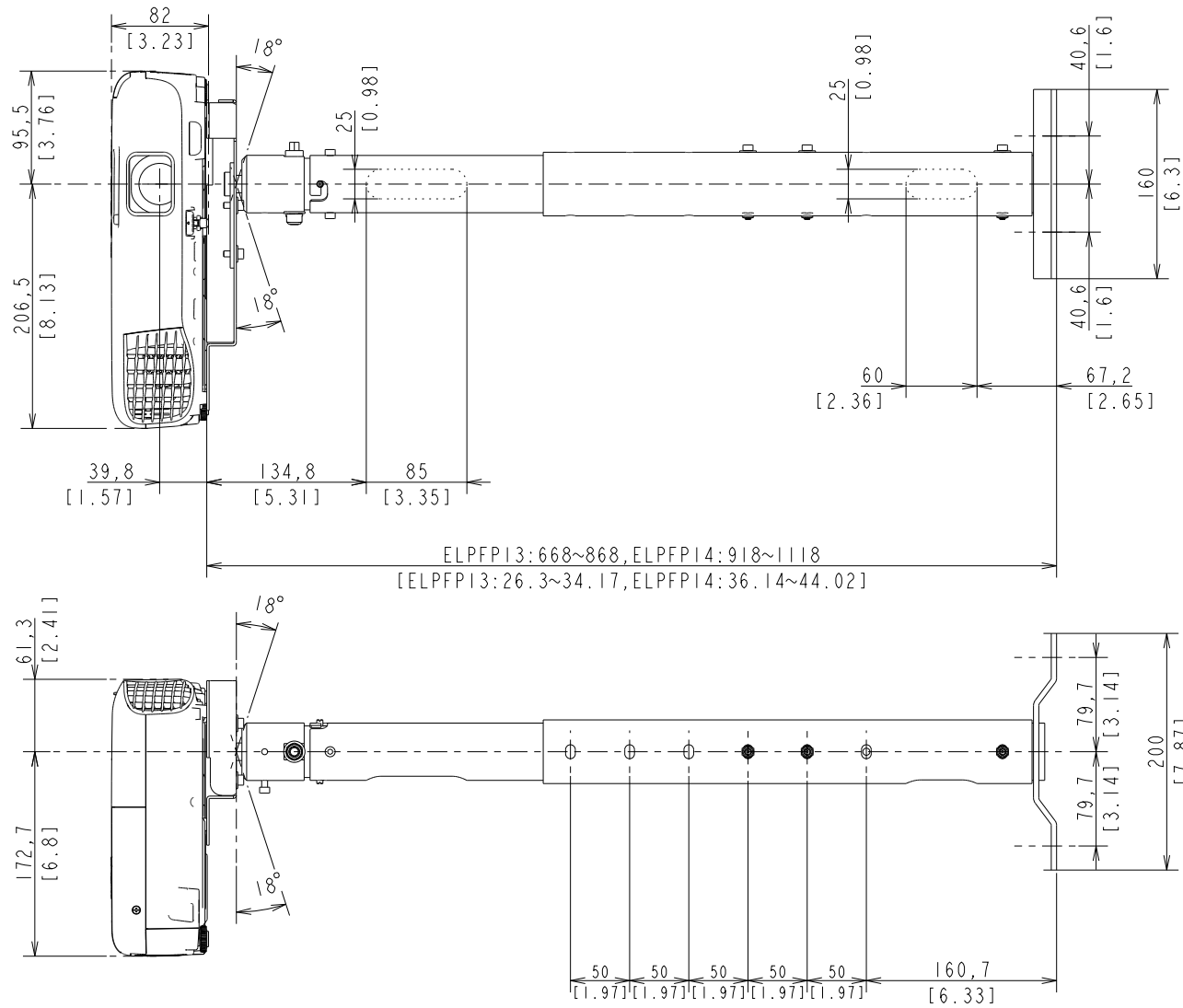

(Note)
 Unit of dimension
 Upper: mm
 Lower: inch

□ EB-FH06/E20/X49/W49/118, PL 119W, EH-TW740/TW750 (ELPMB23)

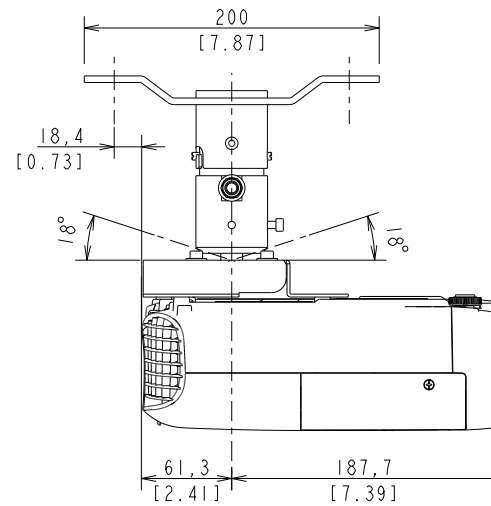
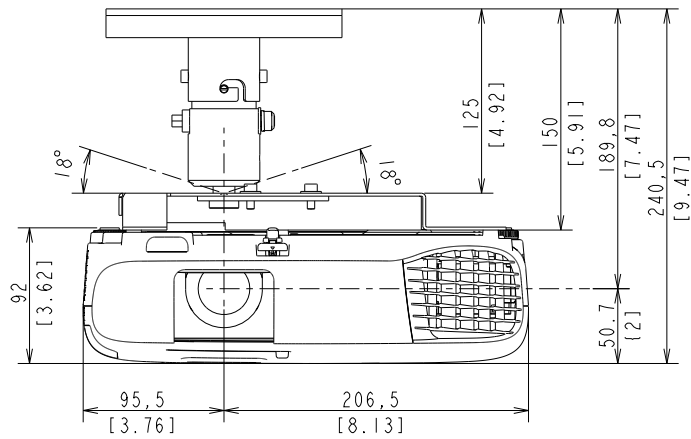
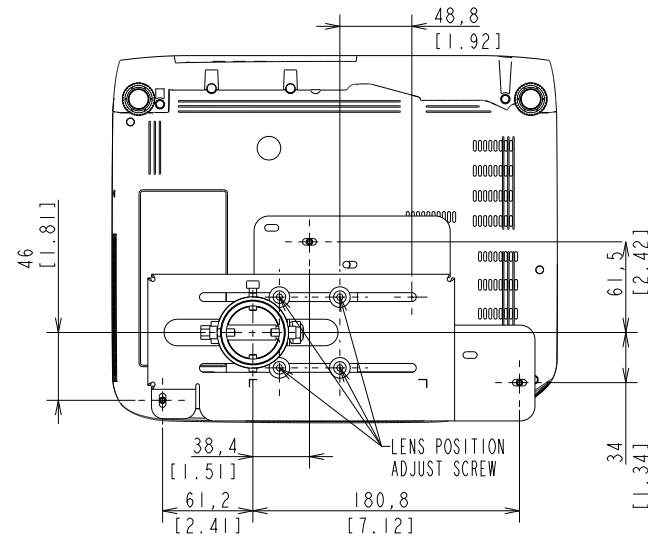
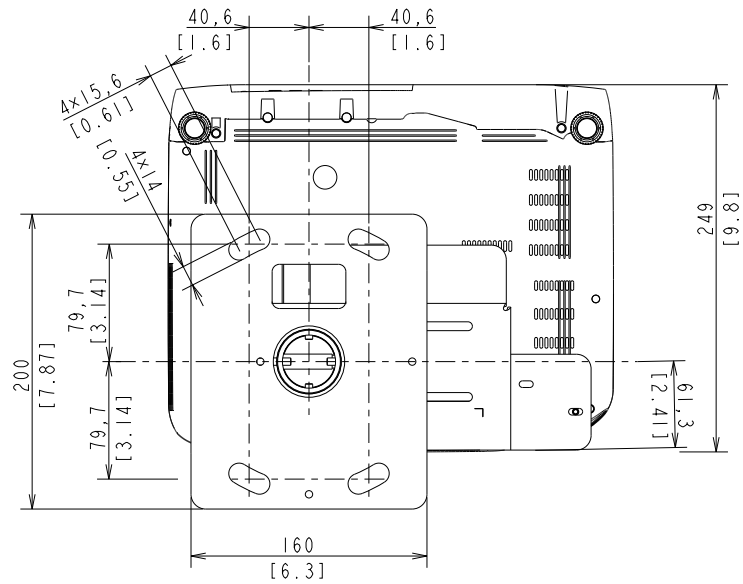

(Note)
Unit of dimension
Upper: mm
Lower: inch

□ EB-FH06/E20/X49/W49/118, PL 119W, EH-TW740/TW750 (ELPMB23 + ELPFP13/ELPFP14)

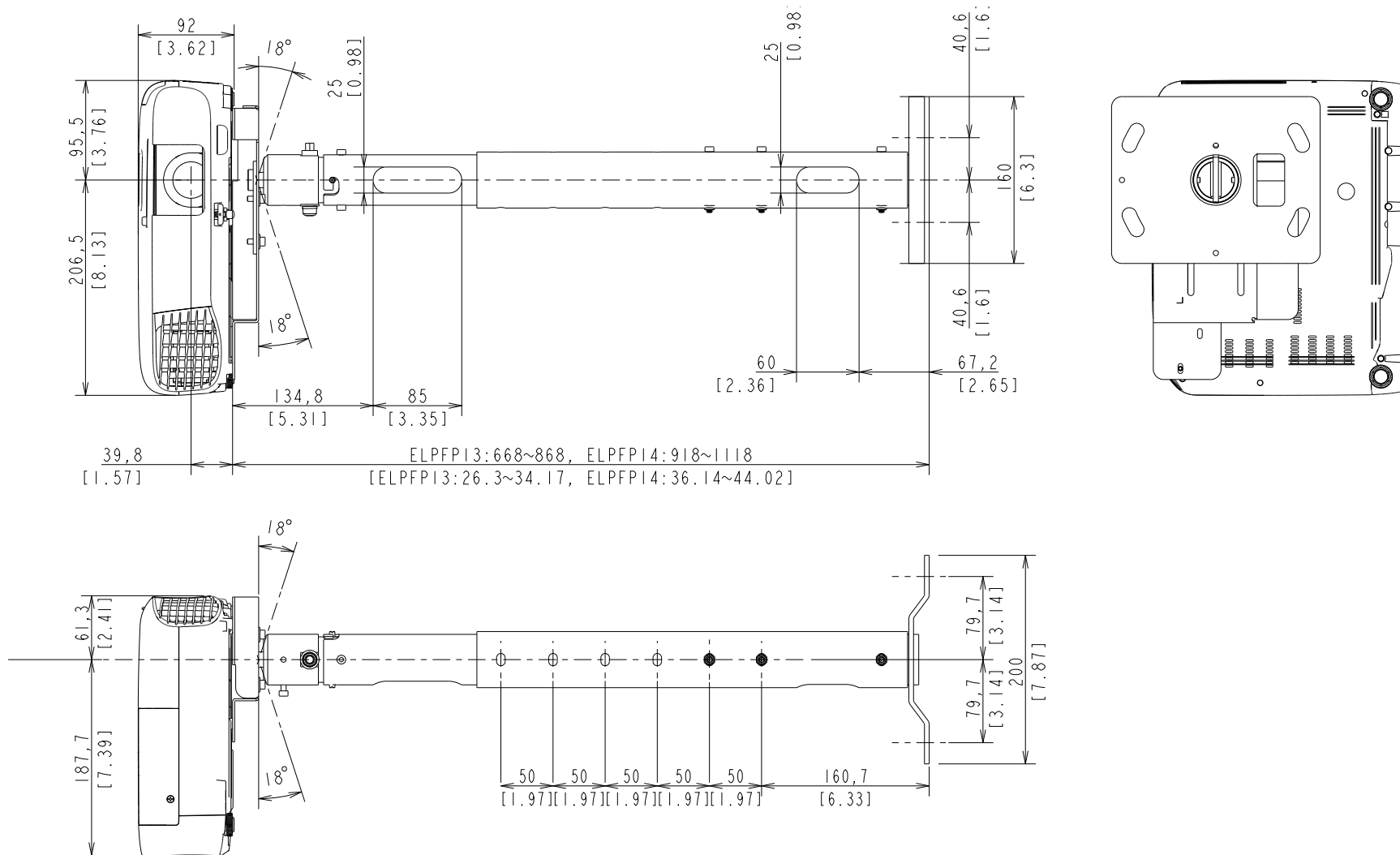

(Note)
 Unit of dimension
 Upper: mm
 Lower: inch

□ EB-FH52/972/982W/992F (ELPMB23)

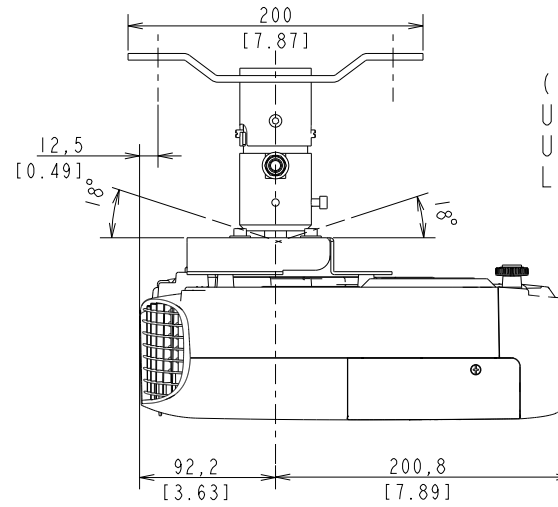
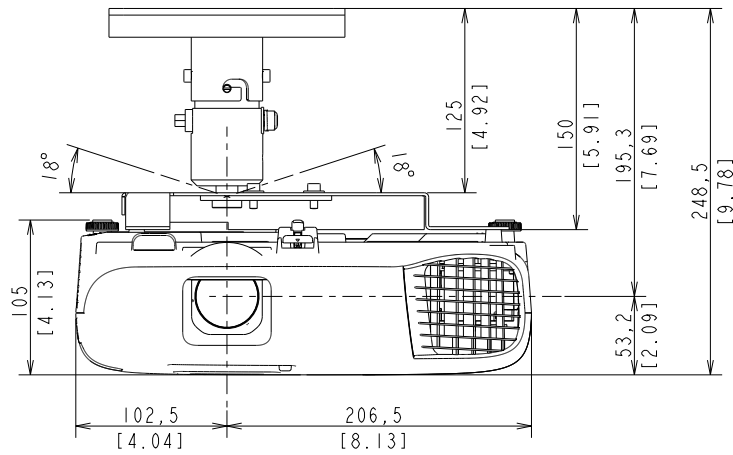
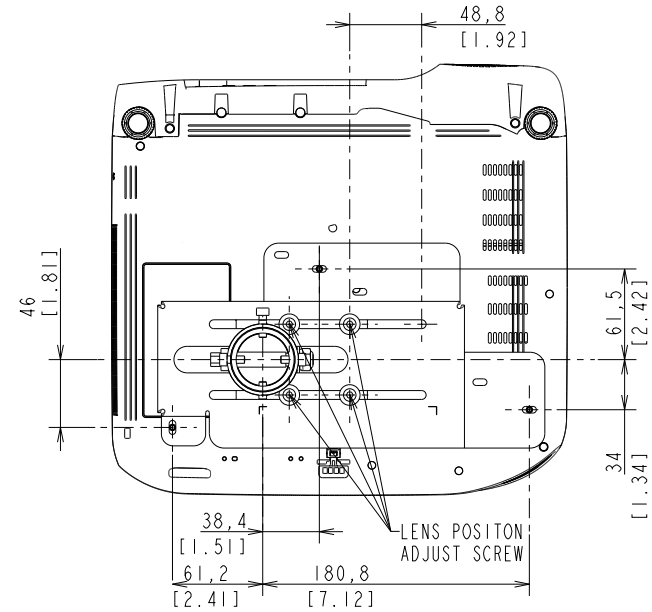
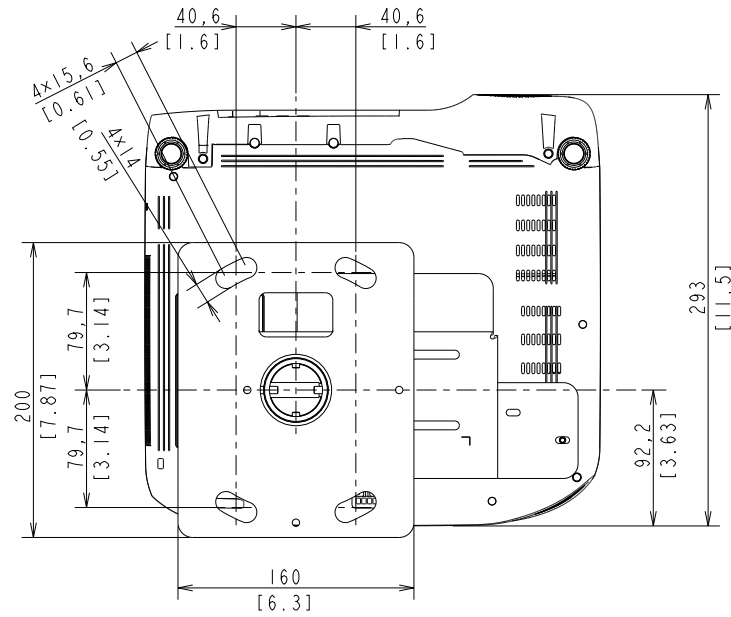

(Note)
Unit of dimension
Upper:mm
Lower:inch

□ EB-FH52/972/982W/992F (ELPMB23 + ELPFP13/ELPFP14)

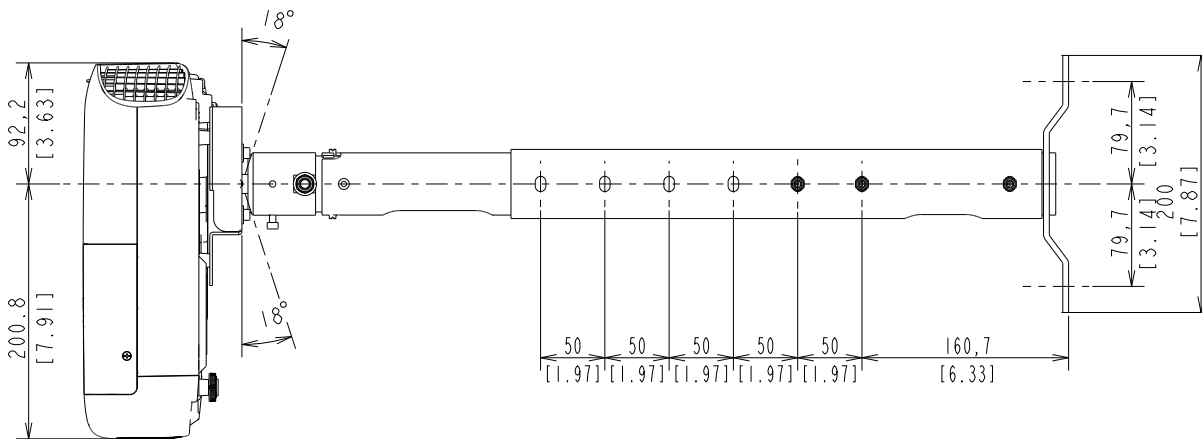
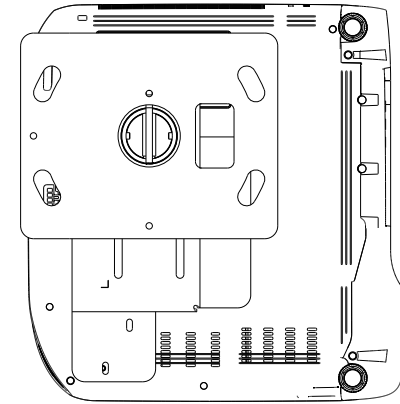
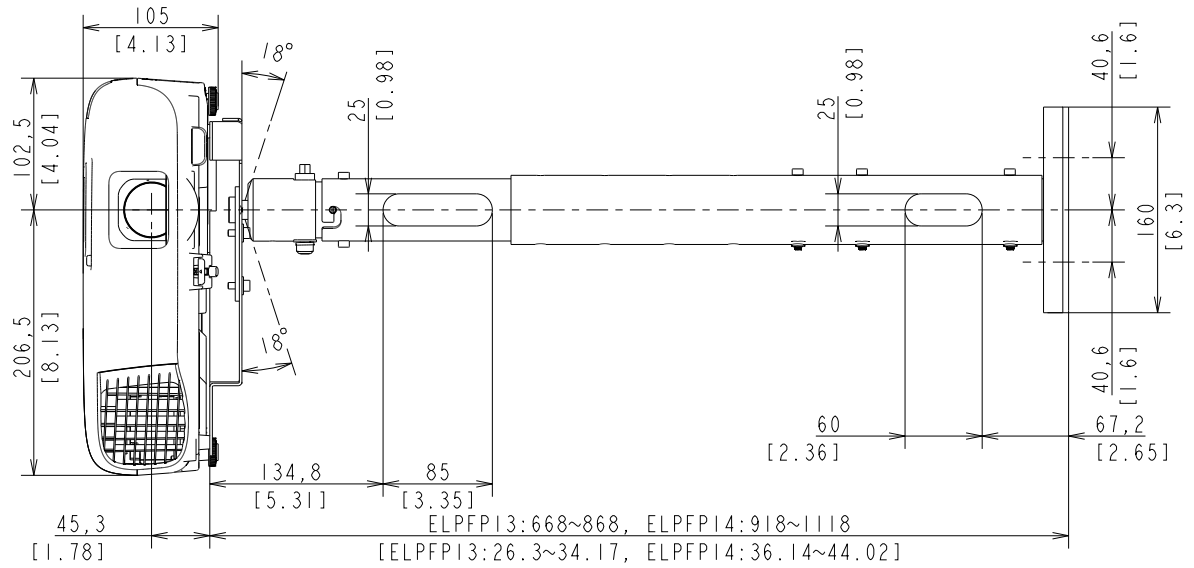

(Note)
Unit of dimension
Upper:mm
Lower:inch

□ EB-W52 (ELPMB23)

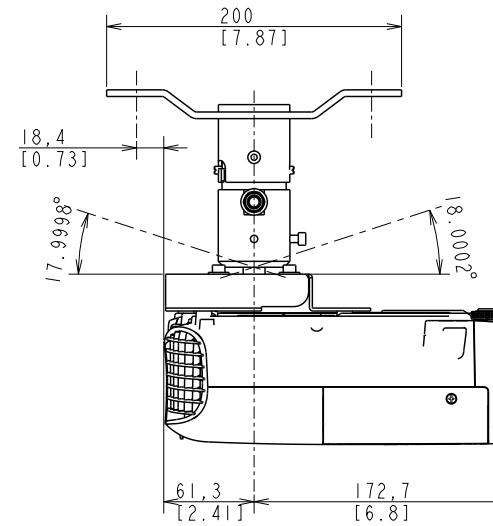
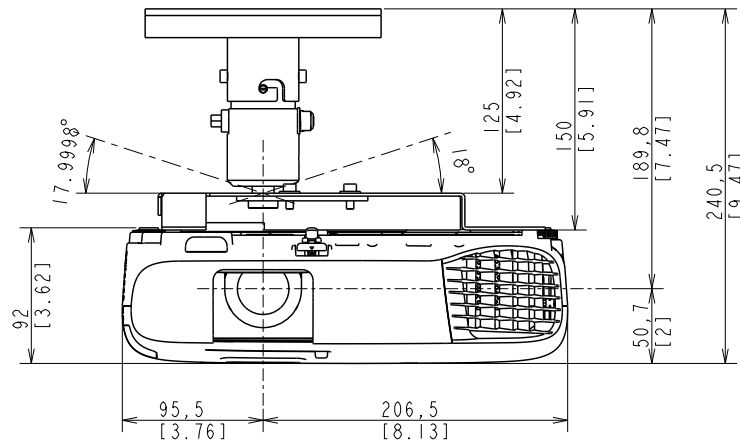
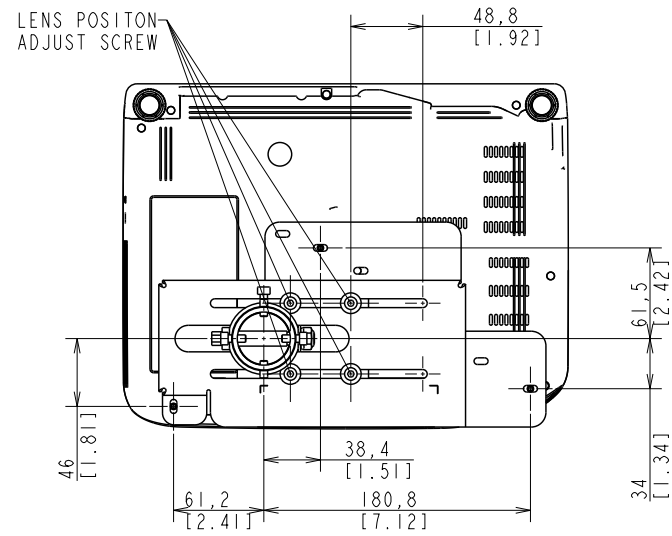
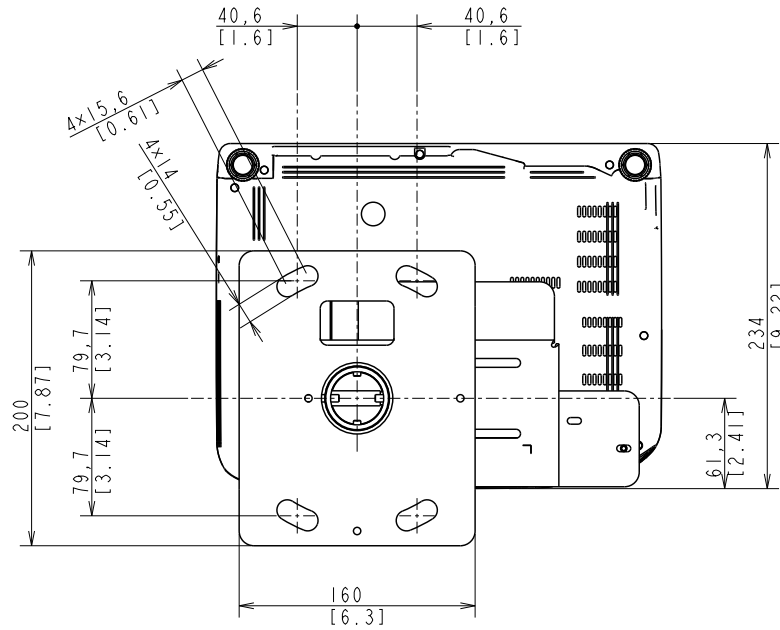

(Note)
Unit of dimension
Upper: mm
Lower: inch

□ EB-W52 (ELPMB23 + ELPFP13/ELPFP14)

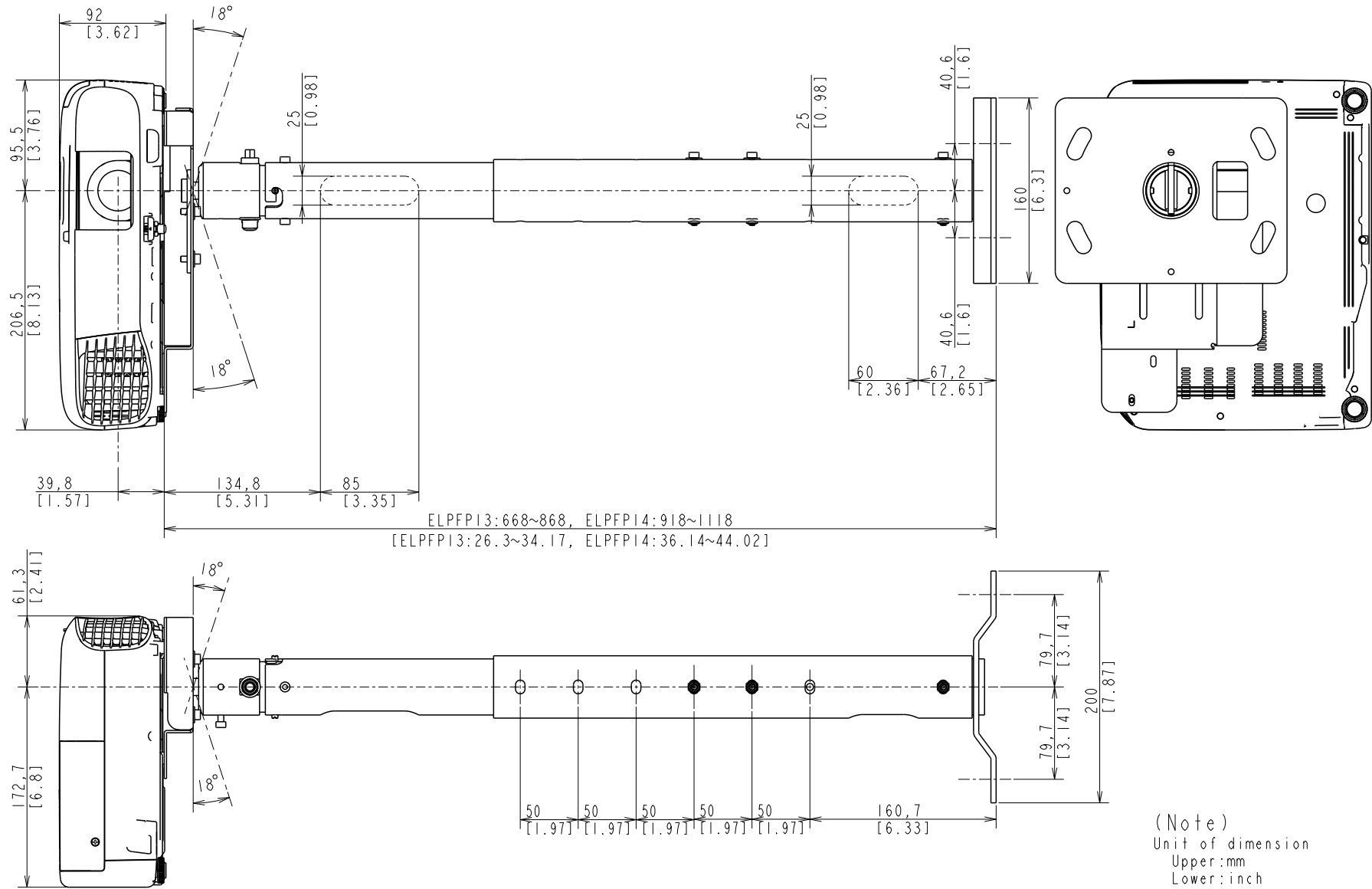

CHAPTER

2

TROUBLESHOOTING

2.1 Required Tools

The following tools are required in order to carry out troubleshooting of this projector.

Name	Qt.	Application/Other
Projection screen	1	To project images on.
Genuine power cable	1	
Genuine remote controller	1	
Host computer	1	To output audio and video data to the projector*1 (To check the component video input)
PC cable	1	To control service tools
Video equipment	1	
Audio and Video cables (HDMI/Composite/USB, and each audio)	1 each	To output audio and video data to the projector*1 (To check the HDMI and composite video input)
Multi tester	1	To measure resistance values and voltages (AC/ DC).
Double-sided tape	q.s.*2	To secure parts
General tools	1 set	Tools given in " 3.1.4 Tools (p66)".
RS-232C cable	1	For writing DR data
USB memory or USB cable	1	For USB Updater
IPS tool	1	
CAT	1	
Intra-mart	1	
RESCUE	1	
USB firmware for updater	1	See " 3.5.10 Service tool list (p150)".
EasyMP Network firmware for updater	1	
Microsoft .Net Framework 3.5 or later	1	
USB COM Driver	1	

*1: When repairing a wide panel (16:10) model, prepare the video source and devices considering the full screen display of 16:10 aspect.

*2: q.s.: Sufficient quantity

2.2 Troubleshooting Procedure

This chapter describes troubleshooting procedure starting from error messages/status to diagnose problems. Refer to the descriptions and remedies below to specify the troubled part, and carry out the necessary repair or replacement.

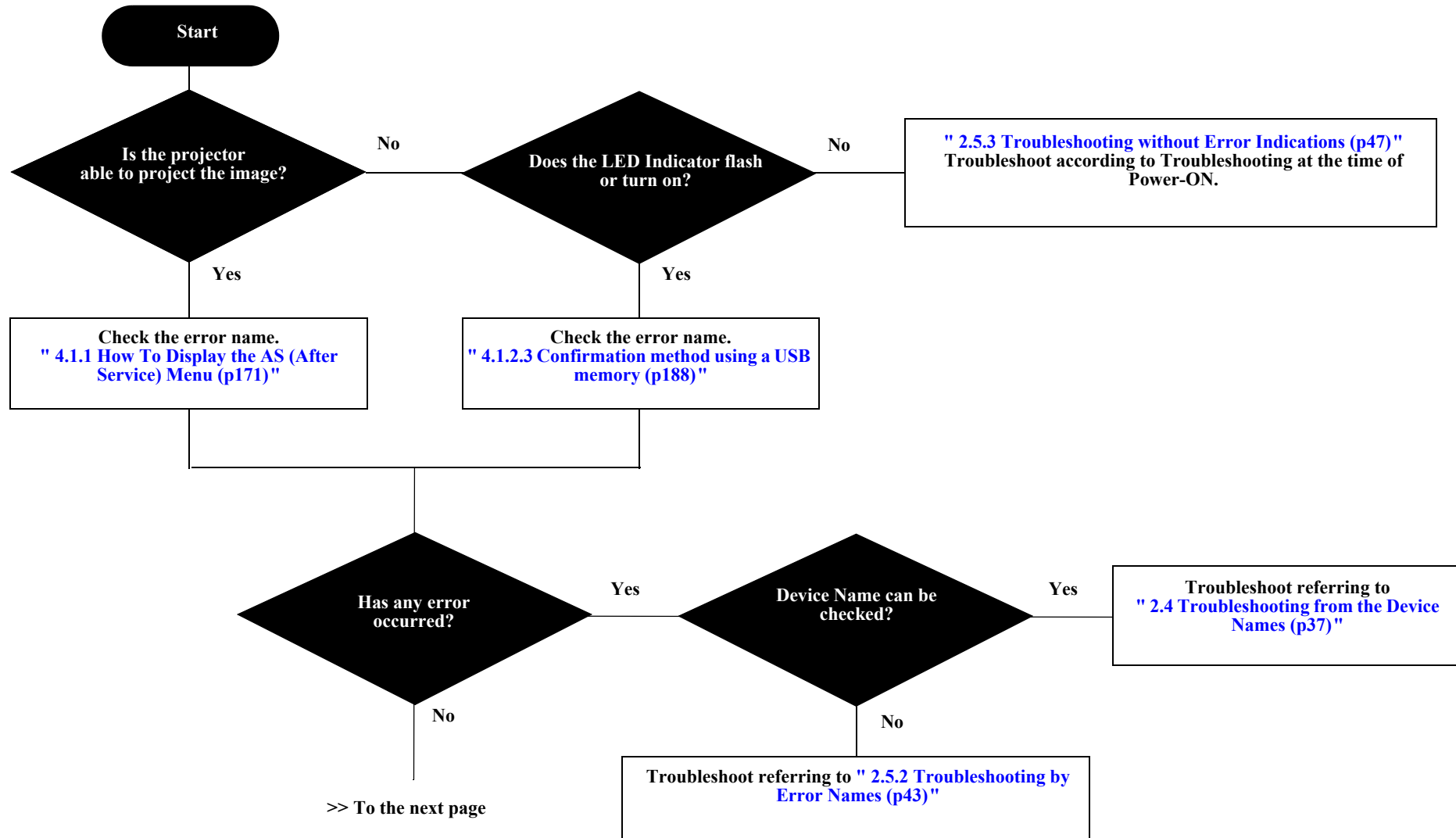

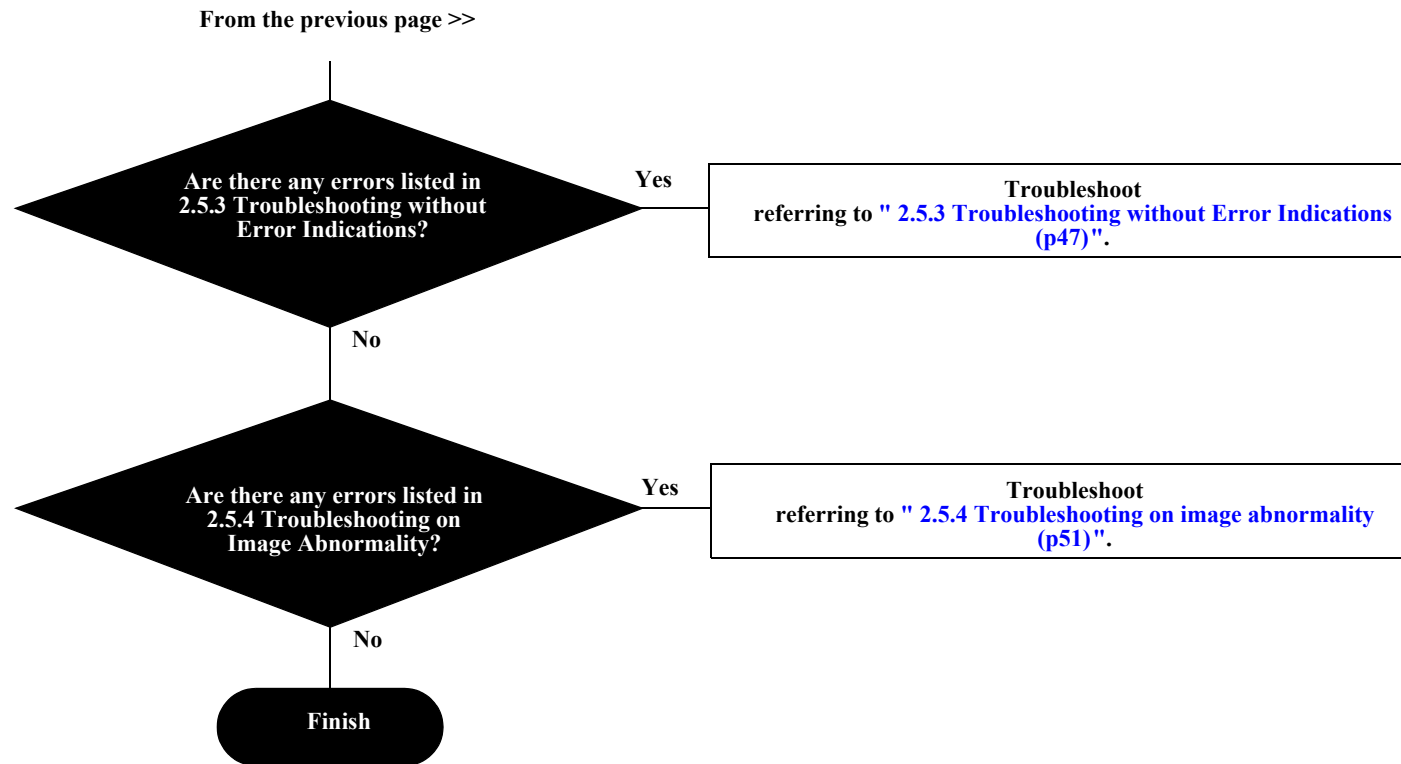

2.3 Exterior Check

When repairing this product, carry out exterior check of the target parts/units as necessary.

Target part	Check items
Upper Case	Any damage/deformation/cracking due to external forces?
	Is it fixed to Lower Case correctly?
	Any foreign object/dirt on IR receiver?
Rear Case	Any damage/deformation/cracking due to external forces?
	Is it fixed to Lower Case and in the frame correctly?
Control panel	Is it fixed to Upper Case correctly?
	Are there any stuck buttons?
	Do buttons work smoothly?
Lamp Cover Unit	Is it fixed to Upper Case correctly?
	Any damage on the latch to operate the Interlock SW? (Remove the lamp cover unit and check it.)
Projection Lens	Does FOCUS RING work smoothly?
	Does Zoom Ring work smoothly?
	Any dirt/scratches on the projection lens?
Lower Case	Any damage/deformation/cracking due to external forces?
	Any foreign object/dirt on it?
Foot	Does Front Foot work smoothly to adjust height?
	Does Rear Foot work smoothly to adjust height?
	Any Foot Rubber detached?
AC Inlet	Any deformation/discoloration on the connector/terminals?
	Any damage on the socket?
Interface (Connector part)	Any deformation/discoloration on the connector/terminals?
	Any foreign objects on the connectors/terminals?
Air Filter	Is it fixed correctly?
	Is there any dirt or foreign substance on the filter? (Remove the air filter and check it.)
	Is there any dirt/foreign substance on the fan inside the filter?

Target part	Check items
Lens Shutter	Any deformation/discoloration on it?
	Is it fixed to Upper Case correctly?
	Does it work smoothly?
Lamp	Any deformation/discoloration on the frame?
	Any deformation/discoloration on the connector?
	Any dirt on the glass surface?

2.4 Troubleshooting from the Device Names



To display the device names, see "[o Error Name/Warning Name/Device ID/Source Name List \(p179\)](#)".

This section explains the troubleshooting mainly for the troubling parts identified using the error names and device codes displayed on the AS (after service) Menu and the IPS tool to carry out their necessary repair. If a device code can be identified through the AS Menu or IPS tool, find the specific troubling part from the table below.

When the troubling part can be identified, the blue-lettered parts with reference pages in the following table can be replaced in shorter ways than the ordinary disassembling procedures.

COOLING SYSTEM COMPONENTS (FAN) [P.58](#)

Error Name (Error Code)	Device Code		CN	Part Name	
	Device Name	IPS tool		Name used in the manual	SPI Parts Name
Fan (FN) (P.40)	LV1	LV1 Fan	CN1602	INT Fan	FAN;SR7039-THT-H838
	LMP	LMP Fan	CN1604	Lamp Fan	FAN,LAMP
	EX	EX Fan	CN1603	EX Fan(P.140)	FAN;TB6035-NMB-H838

COOLING SYSTEM/SWITCH COMPONENTS (SENSOR) [P.59](#)

Error Name (Error Code)	Device Code		CN	Part Name	
	Device Name	IPS tool		Name used in the manual	SPI Parts Name
Thermistor (SE) (P.40)	LMP	LMP TH	CN1601	Lamp Thermistor(P.139)	PCB ASSY;H980TH-MP;PH
	AIR	AIR TH	CN1600	AIR thermistor	
Cover Open (LC)	---	---	CN4 (SW Board)	Lamp Switch	SWITCH,LID LAMP;PH;2

POWER SUPPLY P.61

Error Name (Error Code)	Device Code		CN	Part Name	
	Device Name	IPS tool		Name used in the manual	SPI Parts Name
Thermistor (SE) (P.40)	PS (1)	PS TH	---	PS Ballast Assy	PS BALLAST UNIT ASSY;H838;EP;PH2;5
	PB	BA TH	---		
	PFC (1)	PFC TH	---		

CIRCUIT BOARDS P.62

Error Name (Error Code)	Device Code		CN	Part Name	
	Device Name	IPS tool		Name used in the manual	SPI Parts Name
Thermistor (SE) (P.40)	LV	LV TH	---	MA Board	MA Board Assy;H9**;PH;AS

2.5 Error Indication and Problem diagnosis

2.5.1 Troubleshooting based on LED Indications

This section describes the LED error indications and corresponding error names and their remedies.

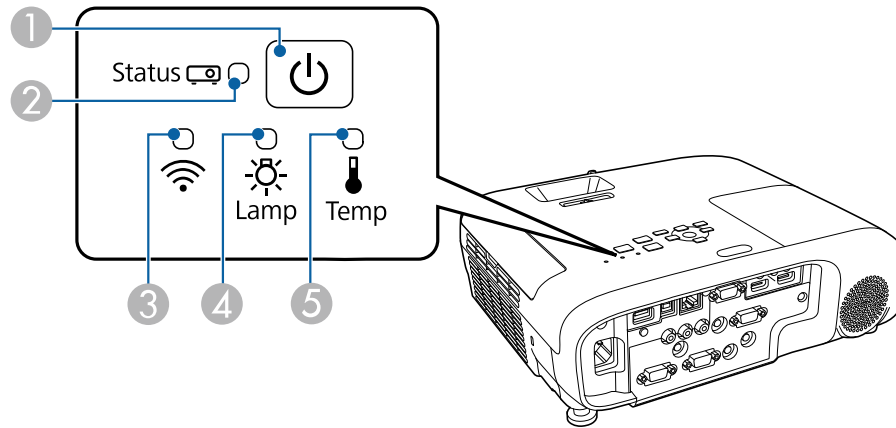





1. Power indicator
2. Status indicator
3. Wireless LAN indicator
4. Lamp indicator
5. Temp indicator

■ ON - ■-Blink ■ OFF





INTERNAL ERROR

LED Status					Corresponding error name	Remedy	Reference
Power	Status	Lamp	Temp	Wireless LAN			
⏻	■-Blink	■-Blink	■	■	<input type="checkbox"/> I2C: I2C H/W Error <input type="checkbox"/> DR: DR Status H/W Error <input type="checkbox"/> RAM: RAM H/W Error <input type="checkbox"/> ROM: ROM H/W Error <input type="checkbox"/> IV: Inner Error (Video sub-processor error)	Disconnect the AC cable once and reconnect it and turn the power back on. If the same error occurs after trying the remedy above, check the error name and carry out the remedy referring to the reference on the right column.	P.45











FAN ERROR/SENSOR ERROR

LED Status					Corresponding error name	Remedy	Reference
Power	Status	Lamp	Temp	Wireless LAN			
					<input type="checkbox"/> Fan: Fan Error <input type="checkbox"/> Thermistor: Sensor Error	Check the connections between each fan/sensor and MA Board. If any connection failure is found, correct it. If the same error occurs when turning the power back on after trying the remedy above, check the error name and carry out the remedy referring to the reference on the right column.	P.44





HIGH TEMPERATURE ERROR/AIR FILTER FLOW REDUCTION ERROR





LED Status					Corresponding error name	Remedy	Reference
Power	Status	Lamp	Temp	Wireless LAN			
					Temp: High Temp Error	1. Check the Air Filter's condition (dirt accumulation, clogging). When clogging or similar is found, clean/replace the filter. 2. If the same error occurs when turning the power back on after trying the remedy above, check the error name and carry out the remedy referring to the reference on the right column.	P.44

AUTO IRIS ERROR/POWER SUPPLY (BALLAST) ERROR

LED Status					Corresponding error name	Remedy	Reference
Power	Status	Lamp	Temp	Wireless LAN			
					Auto Iris: Auto Iris Error	If the same error occurs after turning the power back on, check the error name and carry out the remedy referring to the reference on the right column.	P.45
					Ballast: Power Supply (Ballast) Error		

LAMP ERROR

LED Status					Corresponding error name	Remedy		Reference
Power	Status	Lamp	Temp	Wireless LAN				
					<input type="checkbox"/> Cover Open: Lamp Cover open Error <input type="checkbox"/> Lamp: Lamp Error <input type="checkbox"/> Lamp On: Lamp Lit Error <input type="checkbox"/> Lamp Off: Lamp Failure	Check if the Lamp Cover is installed correctly.	If not, reinstall the Lamp Cover correctly.	P.43
						Check if the Lamp is installed correctly.	If not, reinstall the Lamp Cover correctly.	
						Take out the lamp and check if the Lamp is cracked or damaged.	If the Lamp is not broken, reinstall it and turn the power back on. If the error recurs, replace the Lamp with a new one.	

LED Status					Corresponding error name	Remedy		Reference
Power	Status	Lamp	Temp	Wireless LAN				
					<input type="checkbox"/> Lamp: Lamp Error <input type="checkbox"/> Lamp On: Lamp Lit Error <input type="checkbox"/> Lamp Off: Lamp Failure	Take out the lamp and check if the Lamp is cracked or damaged.	If the Lamp is cracked/damaged, replace it with a new one.	P.43
						Air Filter condition (dirt accumulation, clogging)	If clogging is found, clean or replace the Air Filter.	
						If the projector has been used at a place where is 1500 meters or higher above sea level:	If the High altitude mode is ON, set it to OFF.	
						After trying above remedies:	If the same error occurs after turning the power back on, check the error name and carry out the remedy referring to the references on the right column.	

2.5.2 Troubleshooting by Error Names



To display the error names, see "[o Error Name/Warning Name/Device ID/Source Name List \(p179\)](#)".

This section explains the troubleshooting mainly for the troubling parts identified using the error names and device codes displayed on the AS (after service) Menu and the IPS tool to carry out their necessary repair. If a device code can be identified through the AS Menu or IPS tool, find the specific troubling part from the table below.

TROUBLESHOOTING FROM THE ERROR NAME ON LAMP ERRORS

Error name	Description	Faulty part/part name	Cause	Remedy	Reference
Lamp	Lamp Burnt Out Error	Lamp	Lamp is broken.	Replace Lamp.	P.74
		Air Filter	Air Filter is clogging.	Clean Air Filter. Replace it if not improved.	P.73
		Lamp Switch	Lamp Switch is broken.	Replace Lamp Switch.	P.86
		PS Ballast Assy	PS Ballast Assy is broken.	Replace PS Ballast Assy.	P.122
Lamp On Lamp Off	Lamp lit error Lamp Failure	Lamp	Lamp is broken due to the following reasons: <input type="checkbox"/> Cracks on the arc tube <input type="checkbox"/> Blackening/whitening of the arc tube <input type="checkbox"/> Swelled arc tube	Replace Lamp.	P.74
		PS Ballast Assy	PS Ballast Assy is broken.	Replace PS Ballast Assy.	P.122

TROUBLESHOOTING FROM THE ERROR NAME ON COOLING SYSTEM ERRORS



*: You can identify the broken fan or sensor by checking the device names in the "AS Menu" or IPS tool. For details, see *AS Menu: 5TH Page (p176)*. For the positions of each fan and sensor, see *COOLING SYSTEM COMPONENTS (FAN) (p58)* and *COOLING SYSTEM/ SWITCH COMPONENTS (SENSOR) (p59)*.

Error name	Description	Faulty part/part name	Cause	Remedy	Reference
Temp	Overheat Error	Air Filter	Air Filter is clogging.	Clean Air Filter. Replace it if not improved.	P.73
		Thermistor	Thermistor is broken.	Replace the broken Thermistor.	P.119 P.132
		Thermistor Cable	TH Cable is not connected properly.	Connect TH Cable correctly to MA Board.	P.53
			TH Cable is broken.	Replace the broken TH Cable.	
		Exterior Parts	Vent is deformed or blocked by foreign bodies.	Clean the vent to remove the foreign material.	---
				Replace the parts with deformed vent.	P.89 P.136
		Installation	Not installed correctly.	Improve the installation status. (Place it away from the wall or obstacles)	---
Environment of usage	Intake or exhaust opening is blocked by something	Remove the obstacle from the opening area.	---		
MA Board	Elements for temperature control on MA Board are broken.	If the error continues after carrying out the remedies above, the related circuit on MA Board is broken, replace MA Board Assy.	P.100		
Fan	Fan Error	LV1 LMP EX Fan	TH Cable is not connected properly.	Connect TH Cable correctly to MA Board.	P.53
			TH Cable is broken.	Replace Fan.	P.119 P.121 P.132
			Blades are broken.		
			Revolutions of the fan has become abnormal.		
		Dust is accumulated on the fan.	Clean the foreign material off of the fan.	---	
MA Board	Elements for fan control on MA Board are broken. (Circuit error)	If the error continues after carrying out the remedies above, the related circuit on MA Board is broken, replace MA Board Assy.	P.100		

Error name	Description	Faulty part/part name	Cause	Remedy	Reference	
Thermistor	Sensor Error	LV	Optical engine	FPC is not connected properly.	Connect FPC correctly to MA Board.	P.53
				FPC is broken.	Replace MA Board.	P.100
				The thermistor mounted on the circuit board is broken.		
		LMP LWR	Thermistor	Thermistor is broken.	Replace Thermistor.	P.119 P.132
				TH Cable is not connected properly.	Connect TH Cable correctly to MA Board.	
				TH Cable is broken.	Replace the broken TH Cable.	
		PS(1) PFC(1)	PS Ballast Assy	The thermistor mounted on the main circuit board is broken.	Replace PS Ballast Assy.	P.122
PB	The thermistor mounted on the BA Unit is broken.					

TROUBLESHOOTING FROM THE ERROR NAME ON ELECTRIC CIRCUIT ERRORS

Error name	Description	Faulty part/part name	Cause	Remedy	Reference
RAM	Internal error (RAM)	MA Board	RAM has become abnormal.	Replace MA Board.	P.100
Inner	Internal error (ROM)		Flash ROM is broken. (The number of data rewrite times has exceeded its limit)		
			MA Board is broken.		
I2C	Internal error I2C	Input AC power supply	Instability of the input AC Power Supply. (caused by an external factor)	If not appropriate, request the customer to improve the usage environment. (Refer to "Safety precautions" in the projector's User's Guide)	
		Environment (Temperature of the customer's operating environment)	Access timing error (occurs in a low temperature environment (Y43series))		
DR	Internal error DR	MA Board	MA Board is broken.	Replace MA Board.	P.100
IV	Video sub-processor error				
Auto Iris	Auto Iris Error	Auto Iris Assy	TH Cable is not connected properly.	Connect TH Cable correctly to MA Board.	P.39
			TH Cable is broken.	Replace the Auto Iris Assy.	P.115
			Auto Iris Assy is broken.		
		Moving parts (Gears) of Auto Iris Assy	Foreign material sticks on the part and causes operation failure.	Remove the foreign material in between the gears.	---

Error name	Description	Faulty part/part name	Cause	Remedy	Reference
Ballast	Power Supply (Ballast) Error	PS Ballast Assy	BA Unit is broken.	Replace PS Ballast Assy.	P.122
		PS Cable	TH Cable is not connected properly.	Connect TH Cable correctly to MA Board.	P.53
			TH Cable is broken.	Replace the broken TH Cable.	P.122

2.5.3 Troubleshooting without Error Indications

This section provides troubleshooting procedures based on observed faults.

TROUBLESHOOTING AT POWER-ON

Error Status	Faulty part/part name	Cause	Remedy	Reference
The projector cannot be turned on from the Control Panel. (Power indicator lights up blue, and power can be turned on using the remote controller)	Control panel cable (FFC)	TH Cable is not connected properly.	Connect TH Cable correctly to MA Board.	P.39
		TH Cable is broken.	Replace the control panel.	P.84
	Control panel	Control panel is broken.	Replace the control panel.	
Projector is not turned on (Power LED does not light blue)	PS Ballast Assy	TH Cable is not connected properly.	Connect TH Cable correctly to MA Board.	P.39
		PS Ballast Assy is broken.	Replace PS Ballast Assy.	P.122
	MA Board	MA Board is broken.	Replace MA Board.	P.100

TROUBLESHOOTING ON IMAGE DISPLAY & QUALITY

Error Status	Faulty part/part name	Cause	Remedy	Reference
No image is projected. (Lamp lights)	Input video signal	The selected input video cable is not connected correctly.	Connect the selected input video cable correctly.	---
	MA Board	Video Input terminal is broken.	Replace MA Board.	P.100
Focus cannot be adjusted.	FOCUS RING	FOCUS RING is broken.	Replace FOCUS RING.	P.116
	Projection Lens (Optical Engine)	Projection Lens is broken.	Replace Optical Engine.	P.113
Zoom cannot be adjusted.	Zoom Ring	Zoom Ring is broken.	Replace Zoom Ring.	P.116
	Projection Lens (Optical Engine)	Projection Lens is broken.	Replace Optical Engine.	P.113
Black part of image is reddish.	Optical engine	FPC for L/V (R) is not connected properly.	Connect FPC for L/V (R) to MA Board correctly.	P.39
		FPC for L/V (R) is broken.	Replace Optical Engine.	P.113
	MA Board	MA Board is broken.	Replace MA Board.	P.100
Black part of image is greenish.	Optical engine	FPC for L/V (G) is not connected properly.	Connect FPC for L/V (G) to MA Board correctly.	P.39
		FPC for L/V (G) is broken.	Replace Optical Engine.	P.113
	MA Board	MA Board is broken.	Replace MA Board.	P.100

Error Status	Faulty part/part name	Cause	Remedy	Reference
Black part of image is bluish.	Optical engine	FPC for L/V (B) is not connected properly.	Connect FPC for L/V (B) to MA Board correctly.	P.39
		FPC for L/V (B) is broken.	Replace Optical Engine.	P.113
	MA Board	MA Board is broken.	Replace MA Board.	P.100
Abnormality can be seen on the projected image.	Optical parts	Dirt or problems (deterioration, misalignment, or looseness) of the optical part(s)	Replace Optical Engine.	P.113

TROUBLESHOOTING ON AUDIO INPUT/OUTPUT

Error Status	Faulty part/part name	Cause	Remedy	Reference
Sound does not come out.	Audio Input cables	TH Cable is not connected properly.	Connect the audio input cable correctly.	---
		TH Cable is broken.	Replace the broken audio input cable.	
	Speaker	TH Cable is not connected properly.	Connect TH Cable correctly to MA Board.	P.53
		TH Cable is broken.	Replace Speaker.	P.105 P.121
		Speaker is broken.		
	IF Board	Input terminal is broken.	If the error continues after carrying out the remedies above, the related circuit on IF Board is broken, so replace IF Board.	P.106
		Elements for audio control on IF Board are broken. (Circuit error)		

TROUBLESHOOTING ON OPERATION ABNORMALITY

Error Status	Faulty part/part name	Cause	Remedy	Reference
Operation using Remote Controller cannot be made.	Remote Controller	Batteries ran out.	Replace the batteries with new ones.	---
		Remote Controller is broken.	Replace Remote Controller.	---
	Receiver (RC Filter)	The Lower Case or IF Case receiver is dirty.	Clean Lower Case or IF Case. Replace Lower Case or IF Case if not improved.	P.77 P.136
	Cable (IR Board)	TH Cable is not connected properly.	Connect the cables of the IR Board to the MA Board correctly.	P.53
		TH Cable is broken.	Replace the cables of the IR Board.	P.136
	IR Board	Elements for remote control processing on the IR Board are broken. (Circuit error)	If the error continues after carrying out the remedies above, the circuit on the IR Board is broken, so replace the IR Board.	P.136
IF Board	Elements for remote control processing on the IF Board are broken. (Circuit error)	If the error continues after carrying out the remedies above, the related circuit on IF Board is broken, so replace IF Board.	P.106	
Projector cannot be operated from the control panel.	Control panel cable (FFC)	TH Cable is not connected properly.	Connect TH Cable correctly to MA Board.	P.84
		TH Cable is broken.	Replace the broken TH Cable.	
	SW Buttons	SW Buttons are broken.	Replace the SW Buttons.	
	SW Board	SW Board is broken.	Replace the SW Board.	
MA Board	Elements for operation processing on MA Board are broken. (Circuit error)	If the error continues after carrying out the remedies above, the related circuit on MA Board is broken, so replace MA Board Assy.	P.100	
LED does not light up (Power can be turned on using remote control.)	SW Board	TH Cable is not connected properly.	Connect the cable to MA Board correctly.	P.53
		SW Board is broken.	Replace the SW Board.	P.84
	MA Board	Elements for LED display on MA Board are broken. (Circuit error)	If the error continues after carrying out the remedies above, the related circuit on MA Board is broken, replace MA Board Assy.	P.100
AV Mute does not function even if the shutter is closed.	Lens Shutter Output Switch	TH Cable is not connected properly.	Connect the cable to SW Board correctly.	P.87
		Lens shutter output switch is broken.	Replace the lens shutter output switch.	P.87



TROUBLESHOOTING ON OTHER ABNORMALITY

Error Status	Faulty part/part name	Cause	Remedy	Reference
Smoke/Abnormal odor	Lamp	Burn on foreign objects (dust) from heat.	Clean the area around Lamp to remove the foreign objects.	P.74
	Fan,Lamp	Burn on cables from heat.	Replace the burned cables or parts with new ones.	P.122
	PS Ballast Assy	Burn on circuit board from heat.	Replace PS Ballast Assy.	P.122
Abnormal noises	PS Ballast Assy	Pulse transformer vibrates abnormally.	Replace PS Ballast Assy.	P.122
		BA Unit vibrates abnormally.		
	Fan	Foreign material sticks on a fan.	Clean the foreign material off of the fan.	P.37
		Fan is contacting other parts.	Check if one of the fans contacts with other parts. If so, correct its installation.	
		Fan's impeller is broken.	Replace Fan.	
Operating parts	Screws are loose or fallen off.	Tighten the screws or reassemble the parts.	---	

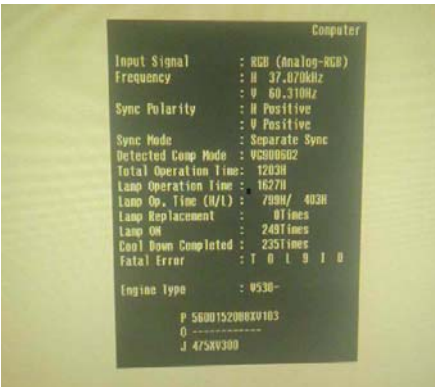

2.5.4 Troubleshooting on image abnormality

The following tables present this projector's possible troubles in image quality, and provides probable causes and troubleshooting procedures based on the observed phenomena.



ILLUMINATION REDUCTION

Phenomenon	Cause	Remedy	Reference
<p>The projected image became darker.</p> 	<p>Some optical parts might mist for some reasons.</p> 	<p>Clean the parts with a cotton swab or the like moistened with ethanol.</p>	<p>Optical Engine Repair Service Manual</p>

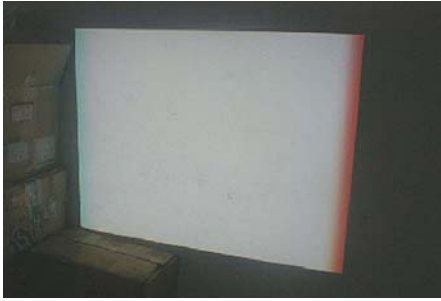

COLOR NON-UNIFORMITY

Phenomenon	Cause	Remedy	Reference
<p>Color non-uniformity can be seen partially in the projected image.</p> 	<ul style="list-style-type: none"> <input type="checkbox"/> Some optical parts may become deteriorated. <input type="checkbox"/> Some optical parts may be broken. 	<p>Replace the deteriorated or broken parts with new ones.</p>	<p>Optical Engine Repair Service Manual</p>

COLOR BANDING (SHADOW)

Phenomenon	Cause	Remedy	Reference
<p>There occur “shadows”* on the right and left side.</p>  <p>* : * “Shadow” is a vertical color banding appearing on the left or right side.</p>	<p>Some optical parts may be displaced due to some shock or the like.</p> 	<p>Re-assemble the defective parts. If the phenomenon not improved, replace the part with a new one. If still not improved, replace the Optical Engine.</p>	<p>Optical Engine Repair Service Manual</p>

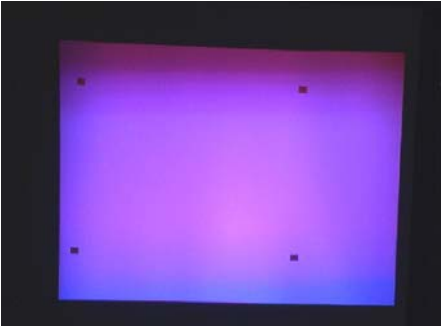
ABNORMAL IMAGE

Phenomenon	Cause	Remedy	Reference
<p>Some abnormality can be seen in the projected image.</p> 	<p>Some optical parts may be detached.</p> 	<p>Re-assemble the defective parts. If the phenomenon not improved, replace the part with a new one.</p>	<p>Optical Engine Repair Service Manual</p>

2.5.5 Cable connection on the MA Board and error symptoms

This section describes the projector's status when disconnection occurs somewhere between the parts/units and the MA Board. If any problem has occurred, refer to the following table and check the doubted connectors are securely connected. If there is a disconnection or a loose connection, connect it correctly.

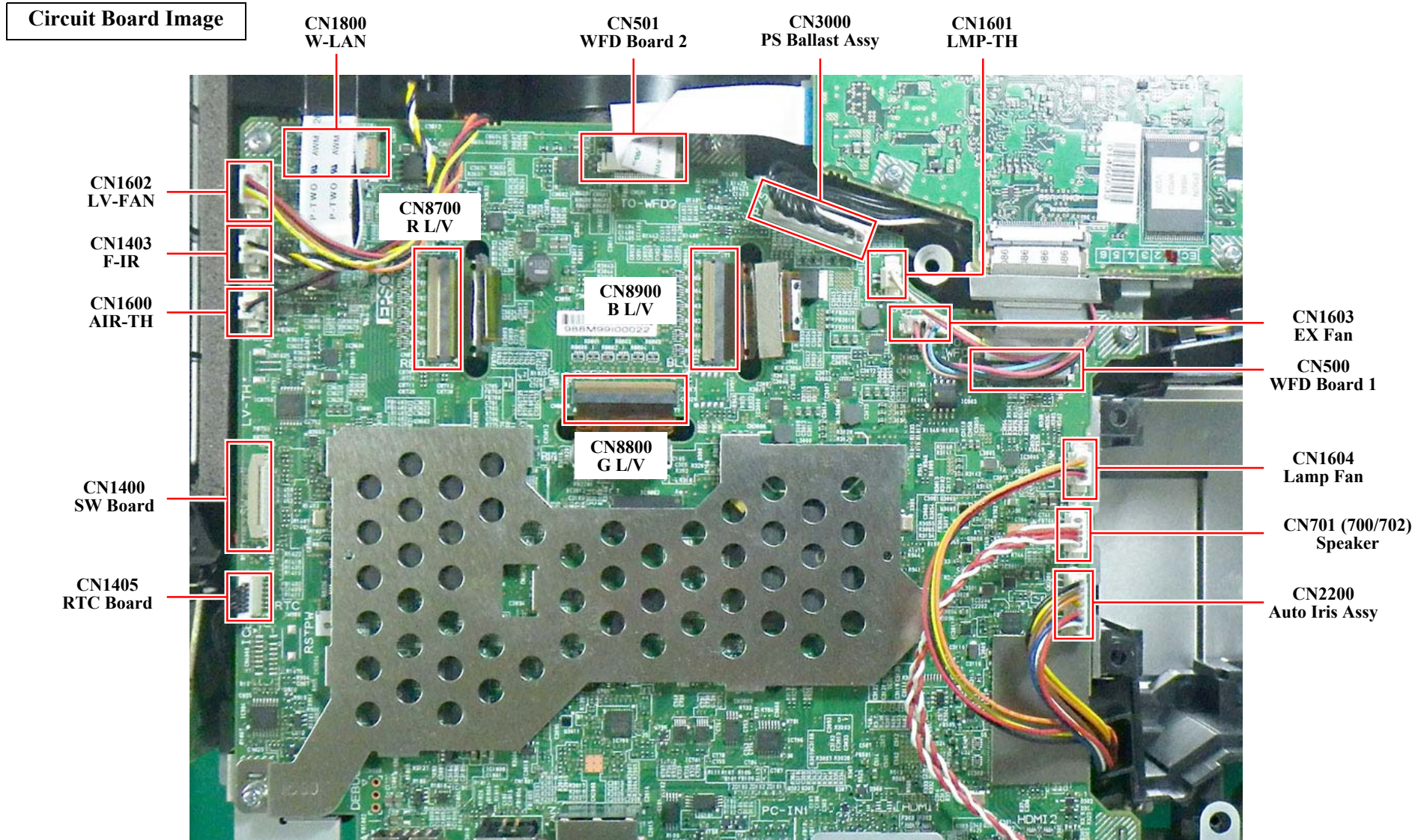

CONNECTION DIAGRAM BETWEEN BOARDS

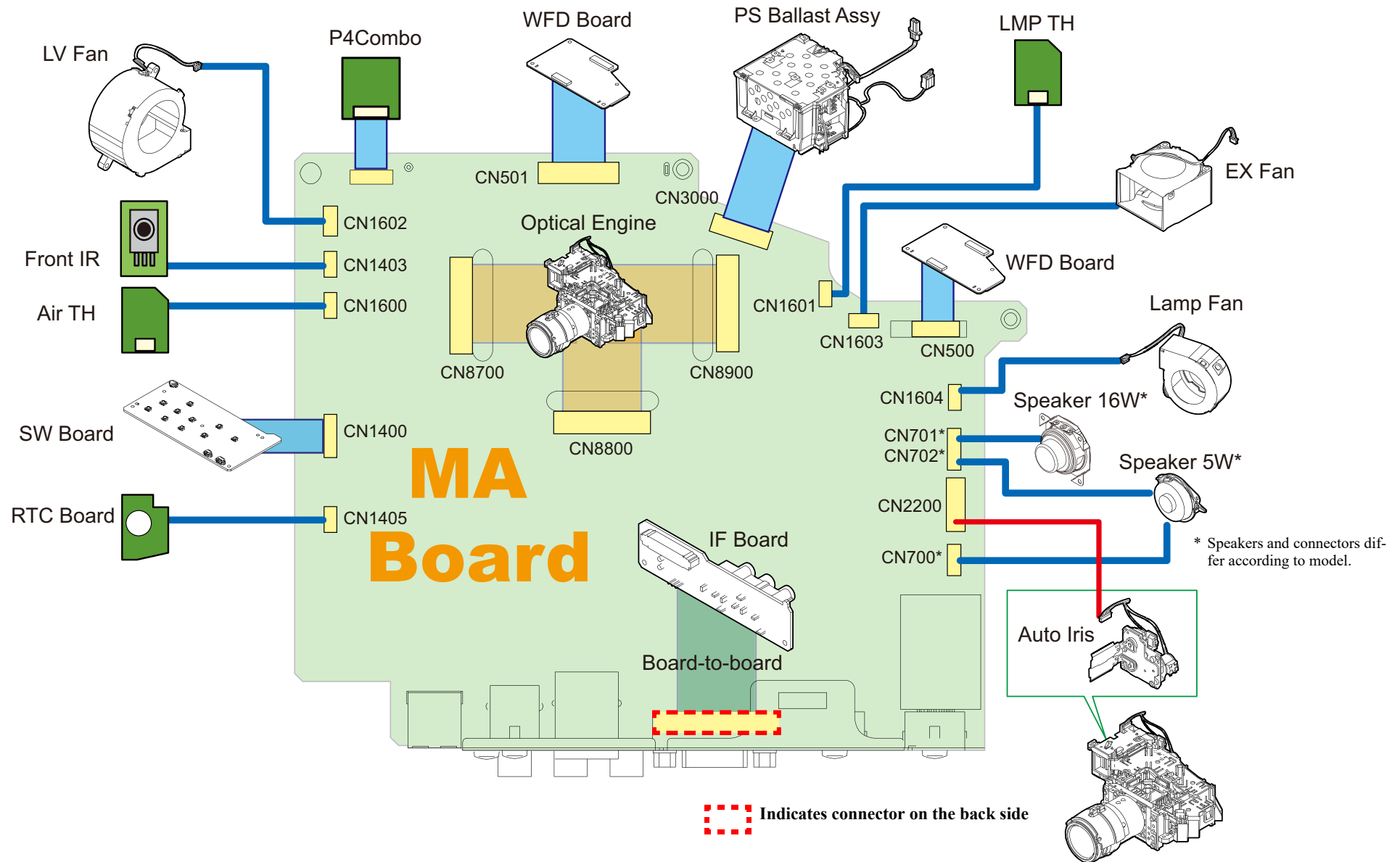

Connector No.	Destination	Error Information		Phenomenon	Reference
		Error Name/ Device Name	Name		
CN8700	Optical Engine (R L/V)	---	---	When pressing the power button, projection starts normally. But the black part of the projected image is reddish.	P.60
CN8800	Optical Engine (G L/V)	---	---	When pressing the power button, projection starts normally. But the black part of the projected image is greenish.	
CN8900	Optical Engine (B L/V)	---	---	When pressing the power button, projection starts normally, then the projection starts. But the black part of the projected image is bluish. (This phenomenon is not easily recognized on Logo screen or No Signal screen; therefore try displaying the menu or the like to check for it.)	
CN3000	PS Unit (P/S)	---	---	When connecting the AC cable, the power LED does not light blue. The power button does not work or power cannot turn on.	P.61
CN1600	AIR-TH	Thermistor AIR	Sensor Error	The power can turn on and after the status LED blinks in blue, temperature LED blinks in orange. When pressing the power button, initialization starts normally but sensor error occurs while initializing. Then LEDs indicate the error, and then the projector turns into the abnormal stand-by status	P.37
CN1601	LMP-TH	Thermistor LMP			
CN1602	LV-FAN	Fan LV1	Fan Error	The power can turn on and after the status LED blinks in blue, temperature LED blinks in orange. When pressing the power button, initialization starts normally but sensor error occurs while initializing. Then LEDs indicate the error, and then the projector turns into the abnormal stand-by status	P.37
CN1603	EX-FAN	Fan EX			
CN1604	LMP-FAN	Fan LMP			
CN500* ¹	WFD Module	WFD	WFD error	The power can turn on and Power LED lights blue. Projection starts normally when the power button is pressed, but the WFD does not function.	P.62
CN501* ¹					
CN1400	SW Board	Cover Open	Lamp cover open error	The power cannot be turned on with the operation panel. However, the power can be turned on with the remote controller. When the power is turned on, the fan rotates at high speed and turns off after a short while. Then the machine goes into abnormal stand-by mode after displaying Lamp Cover Open Error.	P.62
CN1403	IR Board	---	---	Operates normally after the power turns on. However, IR receiver at the front stops working.	P.62
CN1405* ¹	RTC Board	I2C	Internal error	The power can turn on and Power LED lights blue. When pressing the power button, initialization starts but instantly the projector changes to the Internal error mode. After a certain period of cooling, the projector turns into the abnormal stand-by status. The LED Indicator's warning display continues until unplugging the AC cable.	P.62
CN1800* ²	P4Combo	---	---	The power can turn on and Power LED lights blue. Projection starts normally when the power button is pressed, but the W-LAN does not function.	P.62

Connector No.	Destination	Error Information		Phenomenon	Reference
		Error Name/ Device Name	Name		
CN2200	Auto Iris Assy	Auto Iris	Auto Iris Error	The power can turn on and Power LED lights blue. When pressing the power button, initialization starts but instantly the projector changes to the Auto Iris Error mode. The error message in Auto Iris is displayed on the screen, and it advises the user to turn off the power and to contact the Epson Service. When pressing the power button, the LEDs indicate the warning and after a certain period of cooling, the projector turns into the abnormal stand-by status. The LED Indicator's warning display continues until unplugging the AC cable.	P.60
CN700*3	Speaker (2W)	---	---	When pressing the power button, initialization starts normally and the projection starts. However, no sound is output from the speaker even if the audio input is applied. Audio controller on screen display appears, but no sound is output from the speaker even if the audio input is applied.	P.62
CN701*4	Speaker (16W)				
CN702*5	Speaker (5W)				

*1 EB-FH52/992F, EH-TW750

*2 EB-FH52/992F/W52, EH-TW750

*3 EB-E01/X06/W06/E10/X51/W51/W52

*4 EB-FH52/972/982W/992F/118, PL 119W

*5 EB-FH06/E20/X49/W49, EH-TW740/TW750

SW Board

Connector No.	Destination	Error Information		Phenomenon	Reference
		Error Name/ Device Name	Name		
CN1	MA Board (CN1400)	Cover Open	Lamp cover open error	The power cannot be turned on with the operation panel. However, the power can be turned on with the remote controller. When the power is turned on, the fan rotates at high speed and turns off after a short while. Then the machine goes into abnormal stand-by mode after displaying Lamp Cover Open Error.	P.62
CN2*	H Key ASSY	---	---	Operates normally after the power turns on, but the lateral strain of the projected image cannot be corrected.	P.62
CN3*	Lens Cover SW	SH	Shutter error	The power can turn on and Power LED lights blue. When pressing the power button, initialization starts normally and the projection starts. But the lamp does not turn off even when the shutter is closed, and the AV mute does not function. (However, AV mute on the remote controller works normally) Note) Please note that this error may cause troubles such as deformation of the shutter if it is kept closed.	P.59
CN4	Lamp Cover SW	Cover Open	Lamp cover open error	When the power is turned on, the machine goes into abnormal stand-by mode after displaying Lamp Cover Open Error.	P.59

* Not for EB-E01/E10

2.6 Parts Layout Diagrams

COOLING SYSTEM COMPONENTS (FAN)

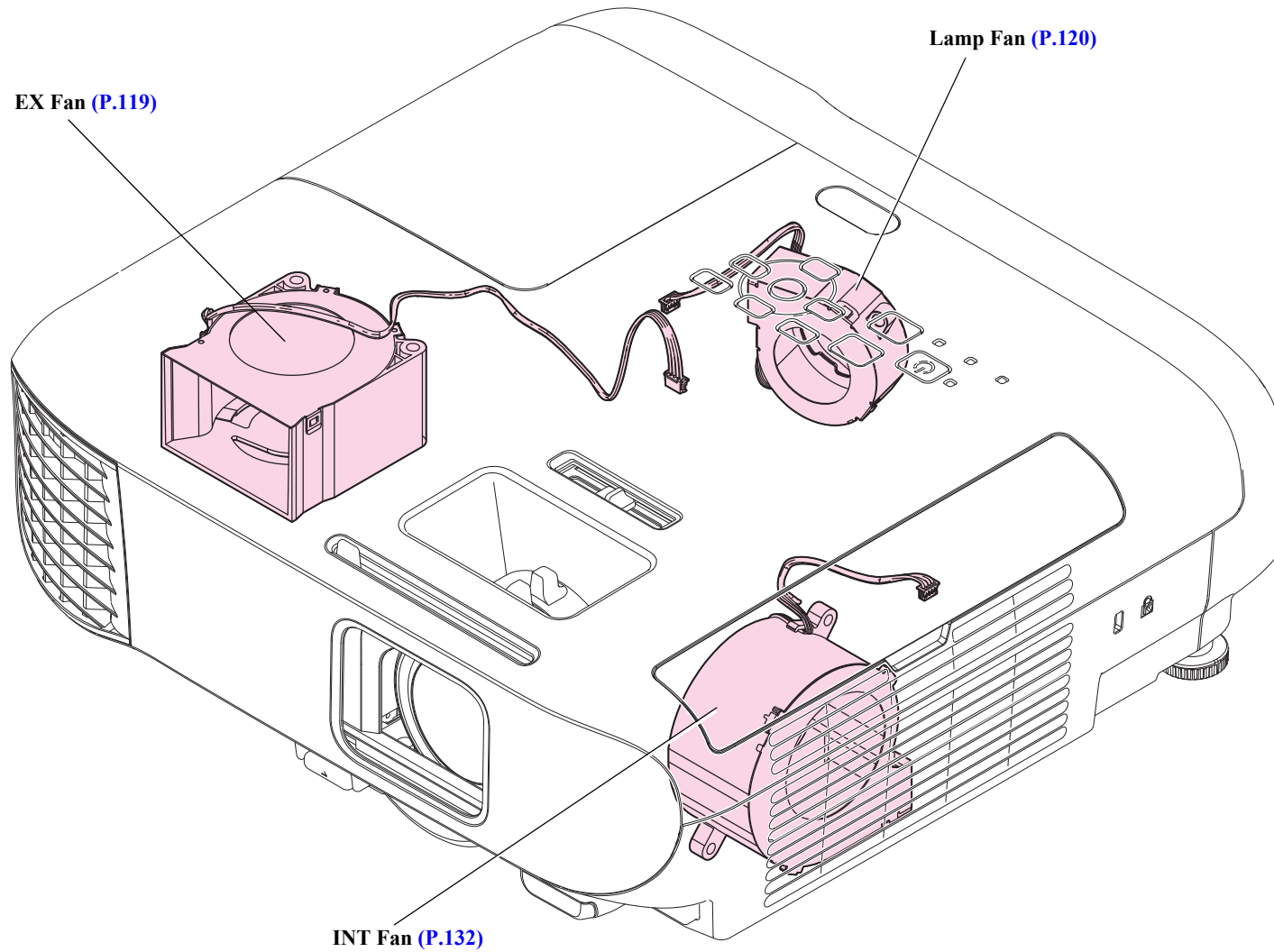

COOLING SYSTEM/ SWITCH COMPONENTS (SENSOR)

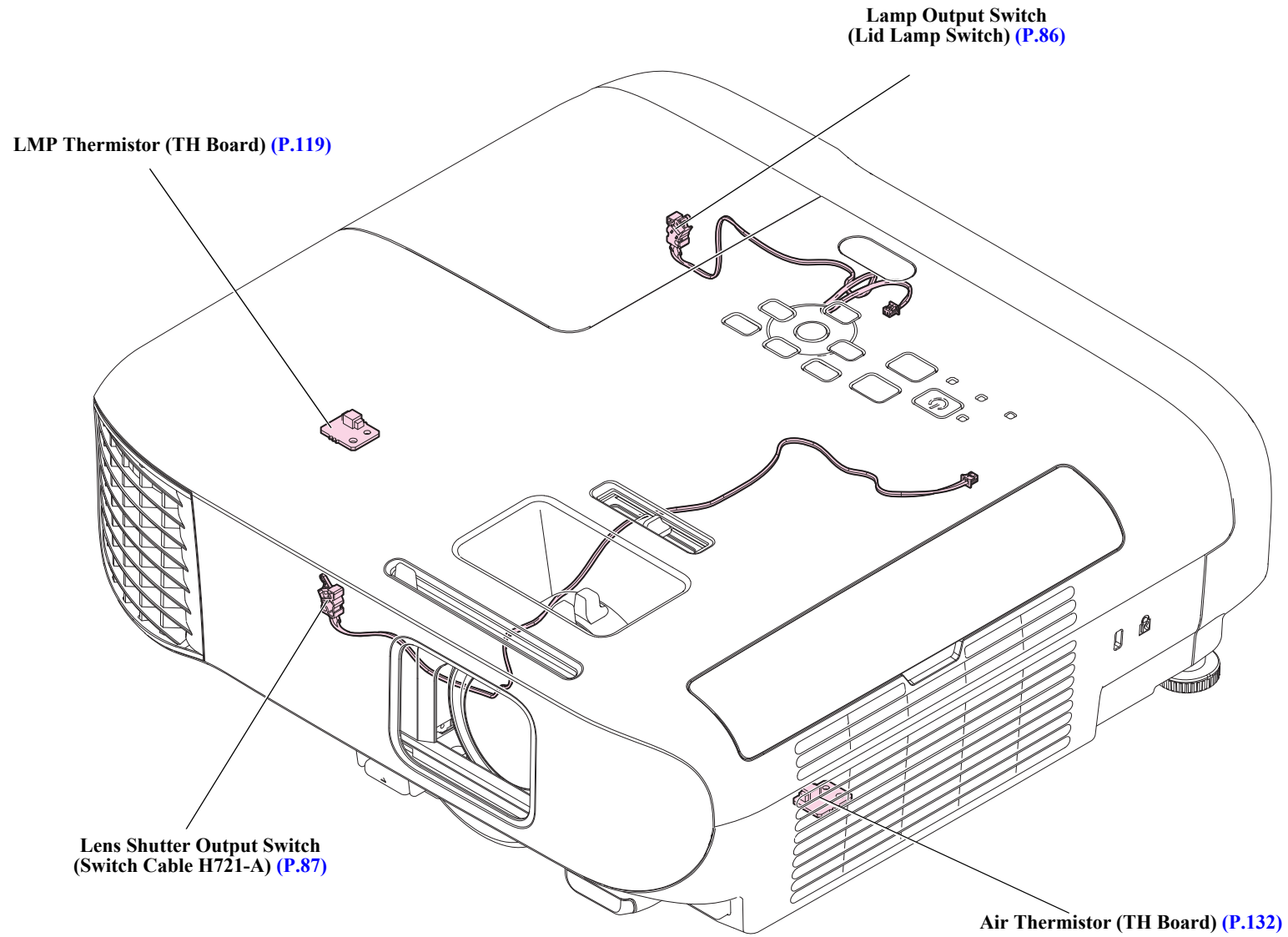

OPTICAL PARTS

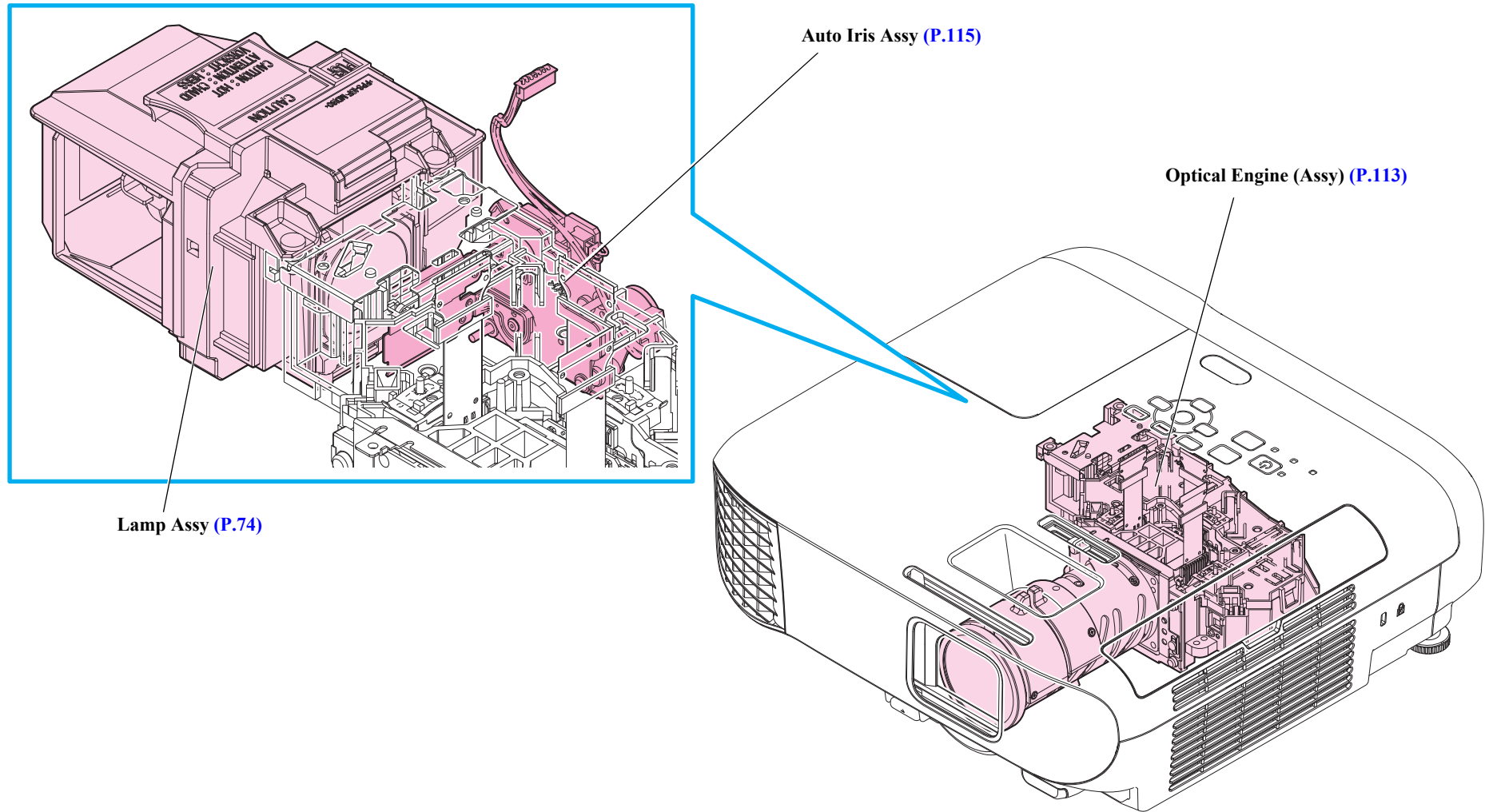

POWER SUPPLY

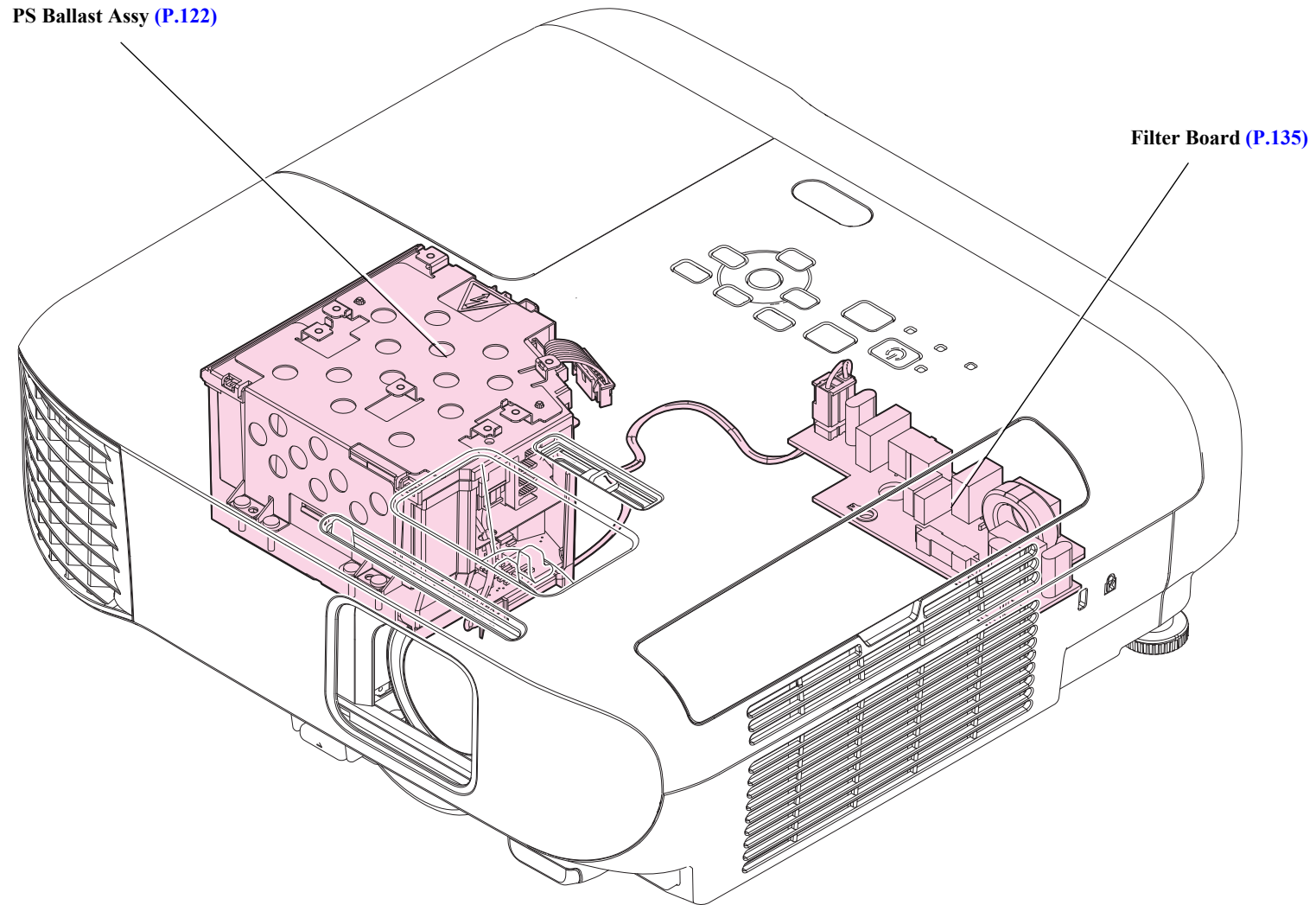

CIRCUIT BOARDS

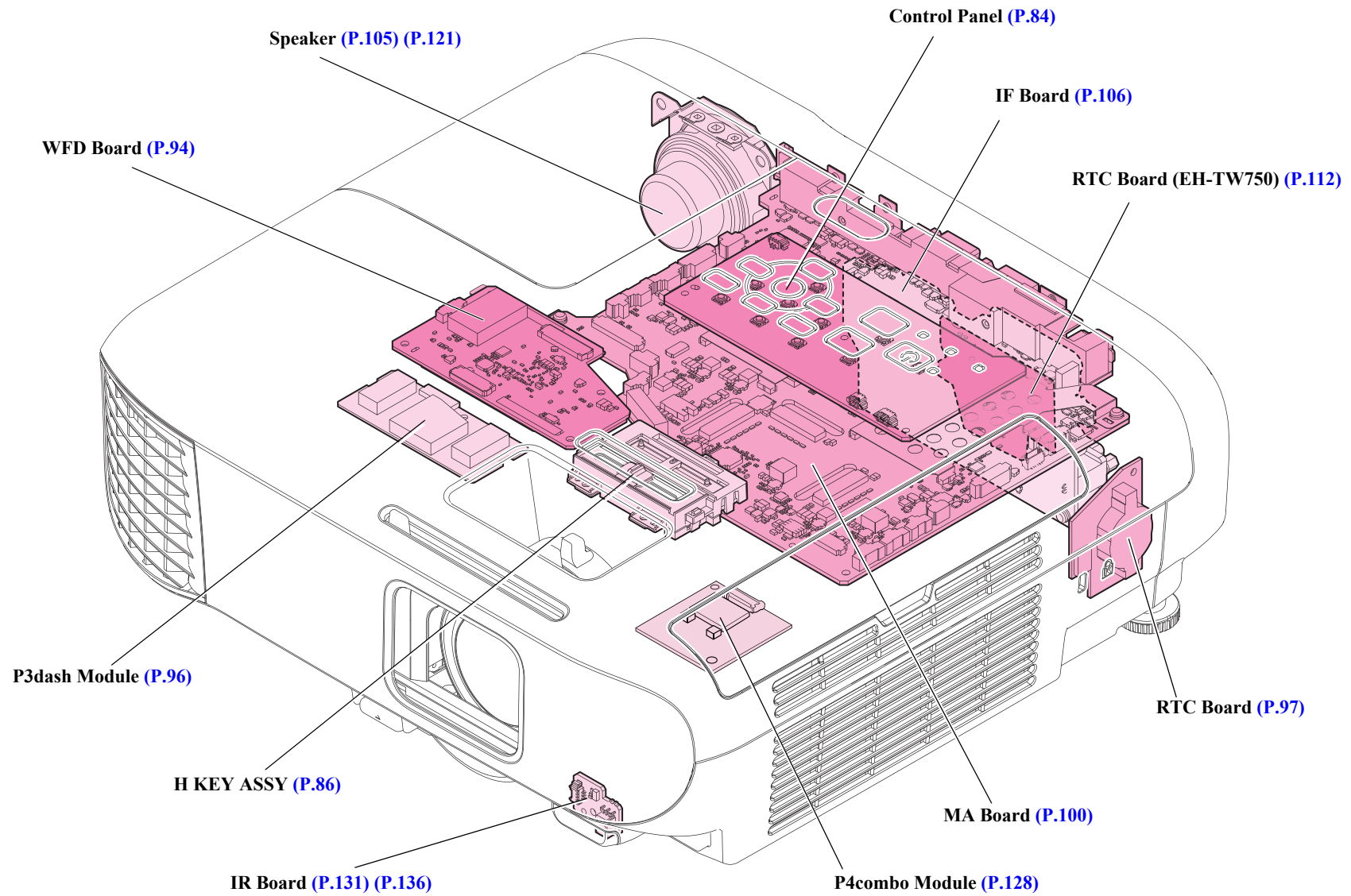

CHAPTER

3

DISASSEMBLY AND ASSEMBLY

3.1 Precautions

This section describes cautions before starting disassembling and assembling this product. Make sure to read the precautions below before starting.

3.1.1 General Cautions in operation

General cautions for disassembling and assembling this product are provided below. Cautions for each procedure are provided in its corresponding section. Make sure to refer to them before starting.

WARNING

- Do not touch the lamp or the parts around it. They are extremely hot even after the cooling down operation completed. If any maintenance work inside the projector is necessary soon after the projector is in operation, leave the unit until it becomes cool enough before performing maintenance work.
- Never use the air blowers such as a lens cleaner that contains flammable gas in repair/maintenance work.

CAUTION

- Do not disassemble any components not as specified in this Service Manual.
- The Optical Engine, the circuit boards are very sensitive to static electricity; therefore, be sure to take appropriate measures to prevent static destruction such as to place them inside static-proof bags once they have been removed from the projector.
- The Optical Engine is very sensitive to vibration and shocks; therefore, make sure to handle it with care.

CAUTION

- The speaker unit contains a permanent magnet; therefore, make sure to keep it away from any storage media such as floppy disks or magnetic cards.
- Be careful not to drop a metal part such as a screw, a washer, or a clip into the inside of the product. If such cases should occur accidentally, never turn on the power supply until all the dropped parts are found and removed.
- When carrying out any of the following operations, check that there is no dust or dirt on any component or on any glass surface before installation. If any contamination is found, clean it off using isopropyl alcohol.
 - Optical Engine removal
 - Lamp removal
- When the projector is disassembled, the dust in and around parts (such as those on the fans or air filter) may get transferred to other parts such as the R, G and B light valves which are the central part of the display mechanism. This may have an adverse effect on the quality of projected images. Be sure to check whether any of the parts are dusty or dirty, and use a vacuum cleaner to clean them first before carrying out disassembly/reassembly work.
- After reassembling the product, check the following before turning the power on. All the parts and screws are installed and secured to the proper positions. No cables are caught in the metal frames.
- For this projector, a calibration is performed for the “Screen Fit” function at the factory shipment. If the “MA Board (Assy)” or later in the flowchart is disassembled for repair, the adjusted values may be misaligned; **therefore, restart the projector and check for abnormalities in the functionality or the projected image.**

3.1.2 Precautions

The precautions given below must be always observed whenever disassembling/reassembling the projector to ensure the safety of service personnel and maintain the quality.

WARNING

- Do not wear the metal products such as a wrist watch, cuff buttons, rings, tie-pin etc. to avoid getting into an unsafe state due to touching the projector.
- When disassembling/assembling the projector, be sure to turn off the power switch and pull out the power cable from the projector beforehand.

CAUTION

- When disassembling/assembling the projector, be sure to wear the gloves and static discharge equipment such as an anti-static wrist strap and a mat.
When replacing the circuit component such as a board or the optical engine, be sure to contact the anti-static case containing the new one to the metal part of this product before taking it out.
- Disconnect all the interface cables from the projector.
- Before disassembling the projector, make sure to clean dust or dirt on the air filter, the interface section and outer cases using a vacuum cleaner or the like.
- When treating the non-after-service-parts as an assembly in this section, they are indicated by "(Assy)".
(Example: "Case Lower (Assy)")

3.1.3 Workflow

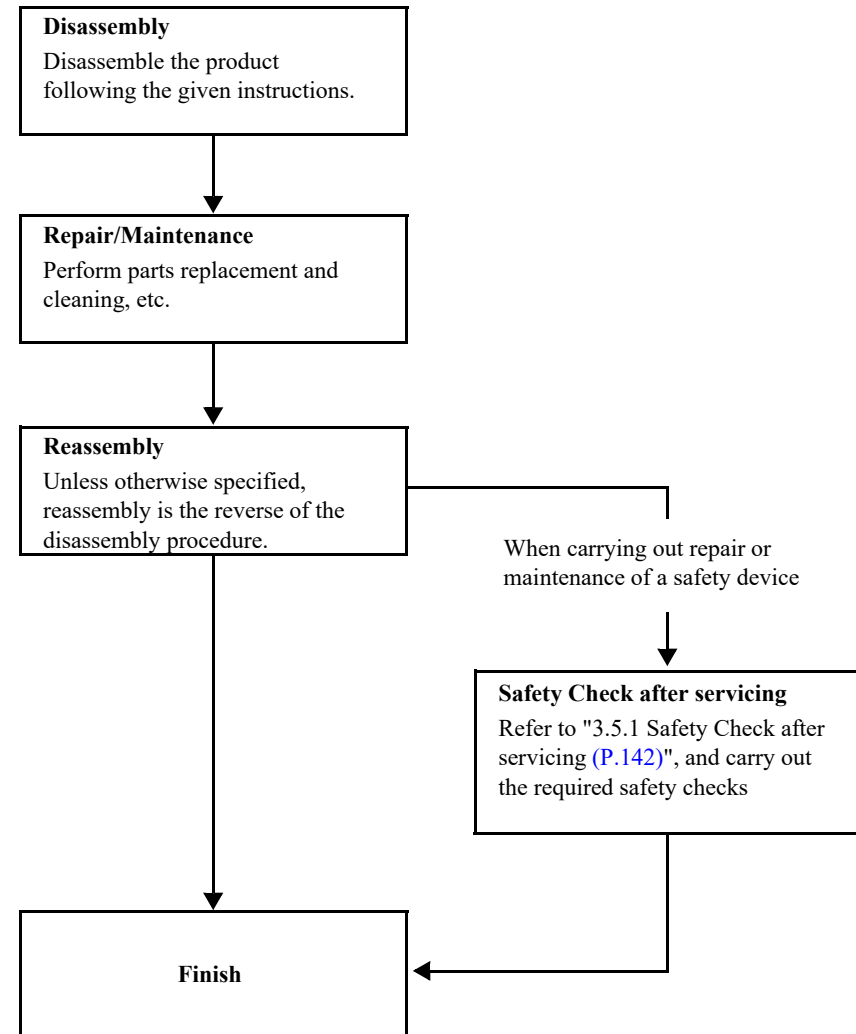

3.1.4 Tools

The following table indicates the tools recommended for use for disassembly, reassembly and adjustment.

3.1.4.1 Tool List

Tool Name	Qt.	Availability	Application
Phillips screwdriver No. 00 (8 cm)	1	✓	Disassembling the Focus Ring and the zoom ring.
Phillips screwdriver No. 1 (10 cm)	1	✓	Disassembling the outer cases and inner components.
Phillips screwdriver No. 2 (10 cm)	1	✓	Disassembling the outer cases and inner components.
Hexagonal box screwdriver (5 mm)	1	✓	Removing the computer interface
Flat-head precision screwdriver	1		Disassembling the Front Foot
Gloves	1	✓	
Anti-static wrist band	1	✓	Be sure to wear them when handling circuit boards or Optical Engine.
Tweezers	1	✓	
Polyimide tape	q.s.*1	✓	Securing cables. Use commercially available Polyimide tape generally called "KAPTON® TAPE".
Brush	1	✓	Cleaning away dust.
Vacuum cleaner	1	✓	Cleaning away dust.
Lens cleaner (nonwoven cloth)	q.s.*1	✓	Cleaning the projection lens.
Lubricant*2	q.s.*1		Lubricating the shutter and its frame.
Projection screen	1	✓	To project images on.
Genuine power cable	1	✓	
Genuine remote controller	1	✓	
Insulation ohmmeter for insulation resistance test	1	✓	Rating: 500 V/100 MW

Tool Name	Qt.	Availability	Application
Multi meter	1	✓	Ground continuity check
Air compressor or hand blower	1	✓	To remove dusts from optical parts and air filter.
Host computer	1	✓	To output audio and video data to the projector (To check the component video input).
PC cable	1	✓	To control service tools
Video equipment	1	✓	To output audio and video data to the projector (To check the HDMI input).
Audio and Video cables (HDMI/Composite/USB, and each audio)	1 each	✓	To check the HDMI input).
Multi tester	1	✓	To measure resistance values and voltages (AC/DC).
RS-232C cable	1	✓	For writing DR data
USB memory or USB cable	1	✓	For USB Updater.
IPS tool	1		See " 3.5.10 Service tool list (p150)".
CAT	1		
Intra-mart	1		
RESCUE	1		
USB firmware for updater	1		
EasyMP Network firmware for updater	1		
Microsoft .Net Framework 3.5 or later	1		
USB COM Driver	1		

*1: q.s.: Sufficient quantity

*2: Usable item = "Grease G-78 (AQUADRY W-0082)"



3.1.4.2 Recommended Tool List

Tool Name	Qt.	Availability	Application
Screwdriver magnetizer	1	✓	To prevent the screw from falling into the projector

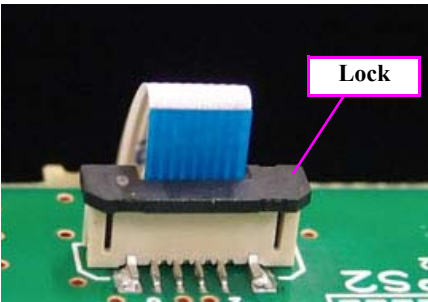
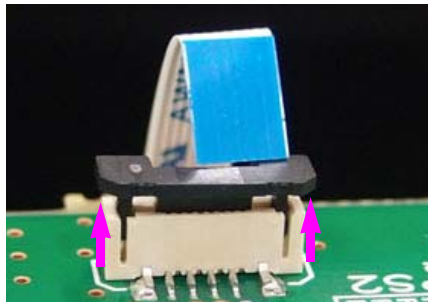
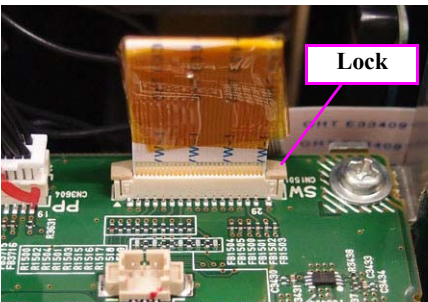
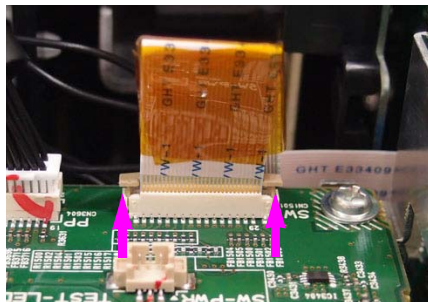
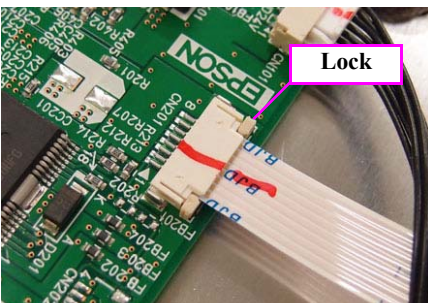
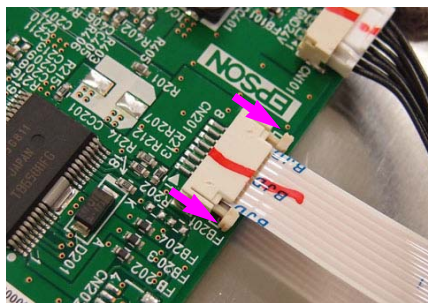
3.1.5 How to unlock connectors for FFC/FPC

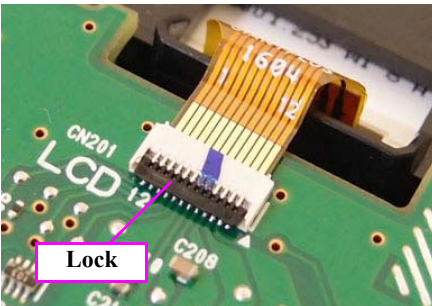
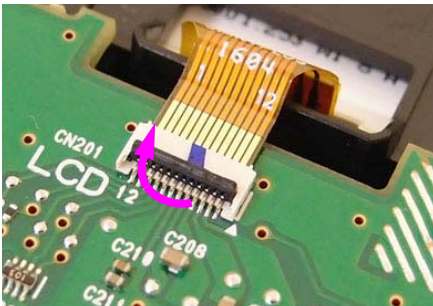
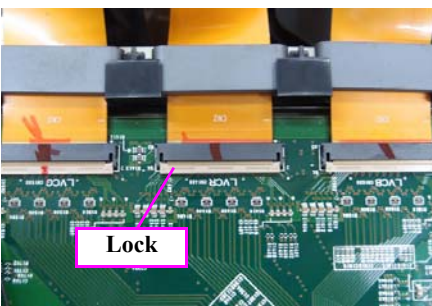
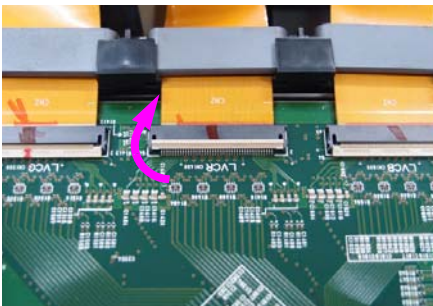
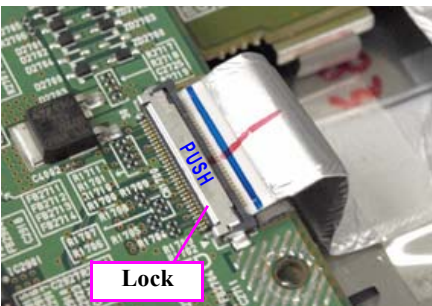
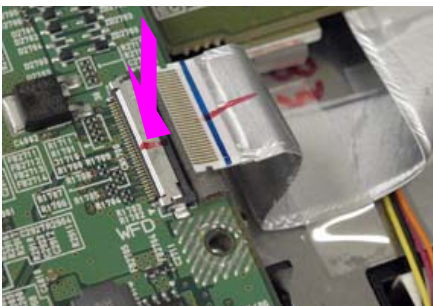
Type	Locked	Unlocked	How to unlock connectors
Slide-open type (upward) #1	 <p>A close-up photograph of a slide-open connector on a green PCB. A blue FFC is inserted. A black plastic lock is in the down position. A pink callout box labeled "Lock" points to the black plastic piece.</p>	 <p>The same slide-open connector as in the previous image, but the black plastic lock is now in the up position, and the blue FFC is partially lifted. Two pink arrows point upwards from the base of the connector.</p>	Slide the lock (black) upward to the FFC to unlock it.
Slide-open type (upward) #2	 <p>A close-up photograph of a slide-open connector on a green PCB. An orange FFC is inserted. A light brown plastic lock is in the down position. A pink callout box labeled "Lock" points to the light brown plastic piece.</p>	 <p>The same slide-open connector as in the previous image, but the light brown plastic lock is now in the up position, and the orange FFC is partially lifted. Two pink arrows point upwards from the base of the connector.</p>	Slide the lock (light brown) upward to the FFC to unlock it.
Slide-open type (toward FFC)	 <p>A close-up photograph of a slide-open connector on a green PCB. A white FFC is inserted. An ivory plastic lock is in the down position. A pink callout box labeled "Lock" points to the ivory plastic piece.</p>	 <p>The same slide-open connector as in the previous image, but the ivory plastic lock is now in the up position, and the white FFC is partially lifted. Two pink arrows point towards the FFC.</p>	Slide the lock (ivory) toward the FFC to unlock it.

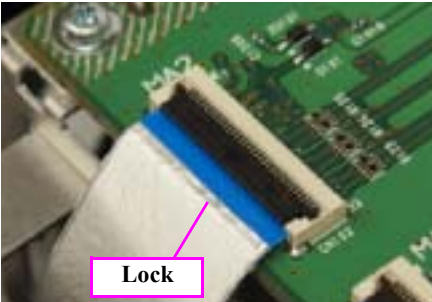
Type	Locked	Unlocked	How to unlock connectors
Flip-open type (FPC)			Flip up the lock (black) on the connector opposite to the FPC to unlock it.
Flip-open type (Wide FPC)			Flip up the lock (ivory) on the connector opposite to the FPC to unlock it. [CAUTION] DO NOT mistake the black part of the connector for the lock because it looks like a lock. Flipping up the black part will damage the connector.
Push-open type			Press and hold the metal plate with a "PUSH" inscription, and disconnect the FFC.

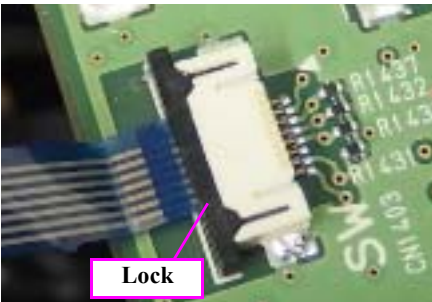
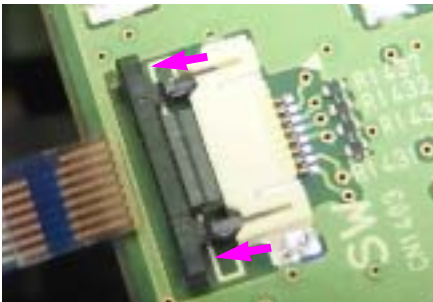
Type	Locked	Unlocked	How to unlock connectors
Flip-open type (FFC)			Flip up the lock (black) of the FFC to unlock it.
Slide-open type (toward FFC)			Slide the lock (black) to the FFC to unlock it.

3.2 Flowchart

EB-E01/X06/W06/FH06/E10/X51/W51/FH52/E20/X49/W49/972/982W/992F/W52/118_EH-TW740/TW750_PL 119W The general disassembly procedure for the projector is illustrated in the flowchart below. Unless otherwise specified, all reassembly should be carried out by following the disassembly procedures in reverse, therefore reassembling procedures are omitted.



- The part names in this chapter are written as abbreviations. See [3.9 Part Names List \(p166\)](#) for the names of the after service parts in the SPI (Service Parts Information).
- The parts in colored boxes are target parts in their category. They are explained in details in the corresponding sections so as to reach the parts in the shortest way.
- The parts in gray boxes are those which are required to be removed to reach the target parts.

3.2.1 Standard operation time

The standard operation time for each operation is provided on the flowchart. Use the time as a guideline for actual operations.

- Basis for the standard operation time
 - A service employee would have sufficient knowledge for the target product's structure, and be able to disassemble/reassemble the product without any reference to guide books.
 - Each operation time is the total time of disassembling/reassembling the target part following the given shortest procedure, and reassembling it.

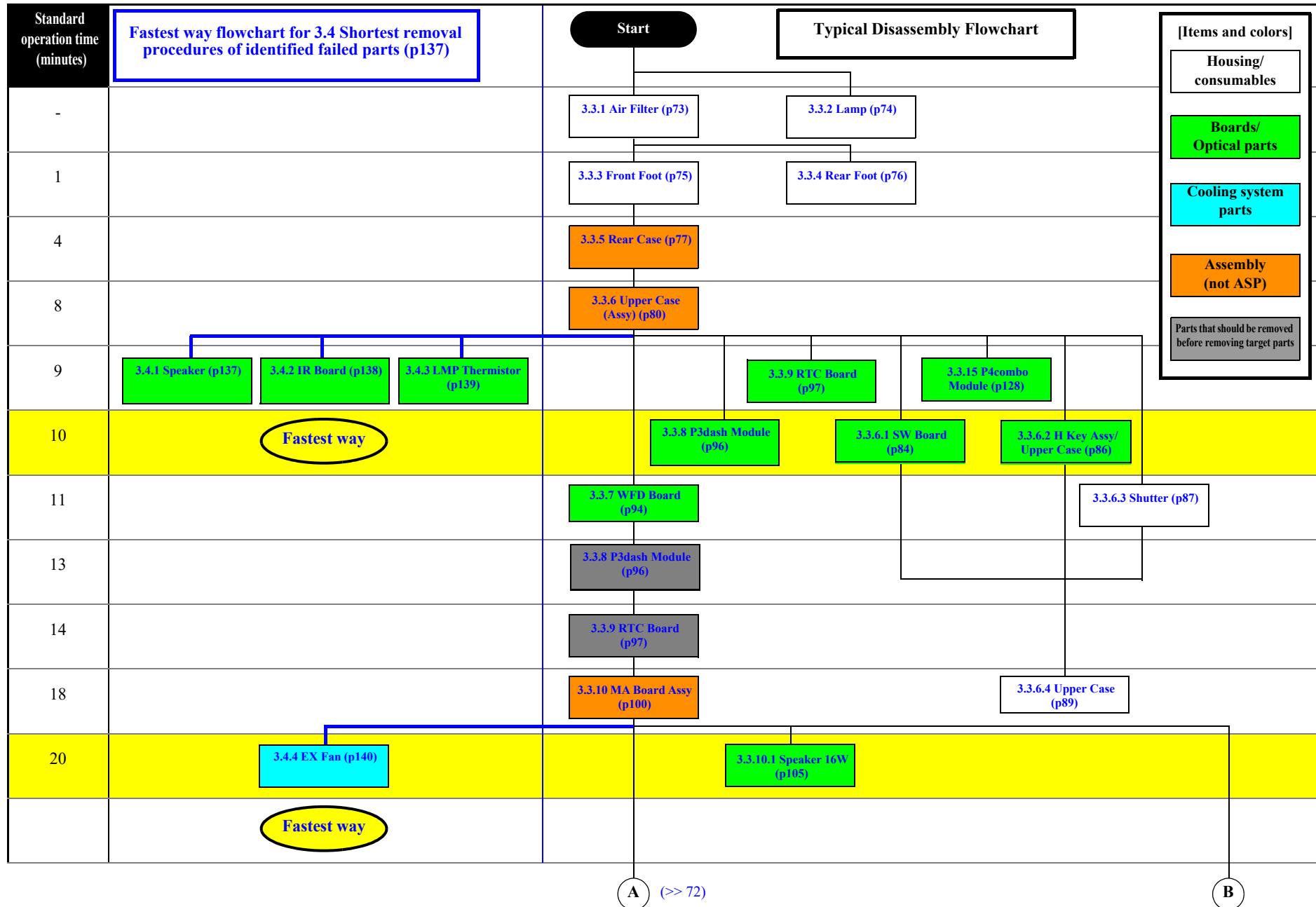

Standard operation time (minutes)	<div style="display: flex; justify-content: space-between;"> (>>> 71) Ⓐ Ⓑ </div>	
22	<div style="text-align: center;"> <div style="border: 1px solid black; background-color: #f4a460; padding: 2px; width: 100px; margin: 0 auto;">3.3.11 Optical Engine (Assy) (p113)</div> </div>	
24	<div style="display: flex; justify-content: space-around; margin-top: 10px;"> <div style="border: 1px solid black; background-color: #a9a9a9; padding: 2px; width: 100px;">3.3.12 EX Duct (Assy) (p118)</div> <div style="border: 1px solid black; background-color: #f4a460; padding: 2px; width: 100px;">3.3.12 EX Duct (Assy) (p118)</div> <div style="border: 1px solid black; background-color: #f4a460; padding: 2px; width: 100px;">3.3.13 Lamp Fan (Assy) (p120)</div> <div style="border: 1px solid black; background-color: #00ff00; padding: 2px; width: 100px;">3.3.11.1 Auto Iris Assy (p115)</div> </div>	
26	<div style="display: flex; justify-content: space-around; margin-top: 10px;"> <div style="border: 1px solid black; background-color: #a9a9a9; padding: 2px; width: 100px;">3.3.13 Lamp Fan (Assy) (p120)</div> <div style="border: 1px solid black; background-color: #00bfff; padding: 2px; width: 100px;">3.3.13.1 Lamp Fan/ Speaker 5W (p121)</div> <div style="border: 1px solid black; background-color: #00ff00; padding: 2px; width: 100px;">3.3.11.2 Focus Ring/ Zoom Ring (p116)</div> </div>	
27	<div style="text-align: center; margin-top: 10px;"> <div style="border: 1px solid black; background-color: #00bfff; padding: 2px; width: 100px;">3.3.12.1 EX Fan/TH Board (p119)</div> </div>	
28	<div style="text-align: right; margin-top: 10px;"> <div style="border: 1px solid black; background-color: #00ff00; padding: 2px; width: 100px;">3.3.10.2 IF Board (p106)</div> </div>	
30		
31	<div style="text-align: center; margin-top: 10px;"> <div style="border: 1px solid black; background-color: #f4a460; padding: 2px; width: 100px;">3.3.14 PS Ballast Assy (p122)</div> </div>	
34	<div style="text-align: center; margin-top: 10px;"> <div style="border: 1px solid black; background-color: #f4a460; padding: 2px; width: 100px;">3.3.16 INT Duct (Assy) (p129)</div> </div>	
35	<div style="text-align: center; margin-top: 10px;"> <div style="border: 1px solid black; background-color: #00ff00; padding: 2px; width: 100px;">3.3.16.1 IR Board (p131)</div> </div>	
36	<div style="text-align: center; margin-top: 10px;"> <div style="border: 1px solid black; background-color: #00ff00; padding: 2px; width: 100px;">3.3.17 Filter Boards (p135)</div> </div>	
38	<div style="text-align: right; margin-top: 10px;"> <div style="border: 1px solid black; background-color: #00bfff; padding: 2px; width: 100px;">3.3.16.2 INT Fan/TH Board (p132)</div> </div>	
39	<div style="text-align: center; margin-top: 10px;"> <div style="border: 1px solid black; background-color: #e0e0e0; padding: 2px; width: 100px;">3.3.18 Lower Case/IR Board (p136)</div> </div>	

3.3 Disassembly and Assembly



The part names in this chapter are written as abbreviations.

See [3.9 Part Names List \(p166\)](#) for the names of the after service parts in the SPI (Service Parts Information).

3.3.1 Air Filter

DISASSEMBLY PROCEDURE

1. Remove the "Air Filter Cover".
2. Remove the "Air Filter Assy".



■ EB-E20/X49/W49/972/982W/992F/118, PL 119W

If the "Air Filter Cover Band" is removed from the "Air Filter Cover", the end of the band will be deformed and the fixing force will be reduced. When reassembling, be sure to replace the "Air Filter Cover Band" with a new one.

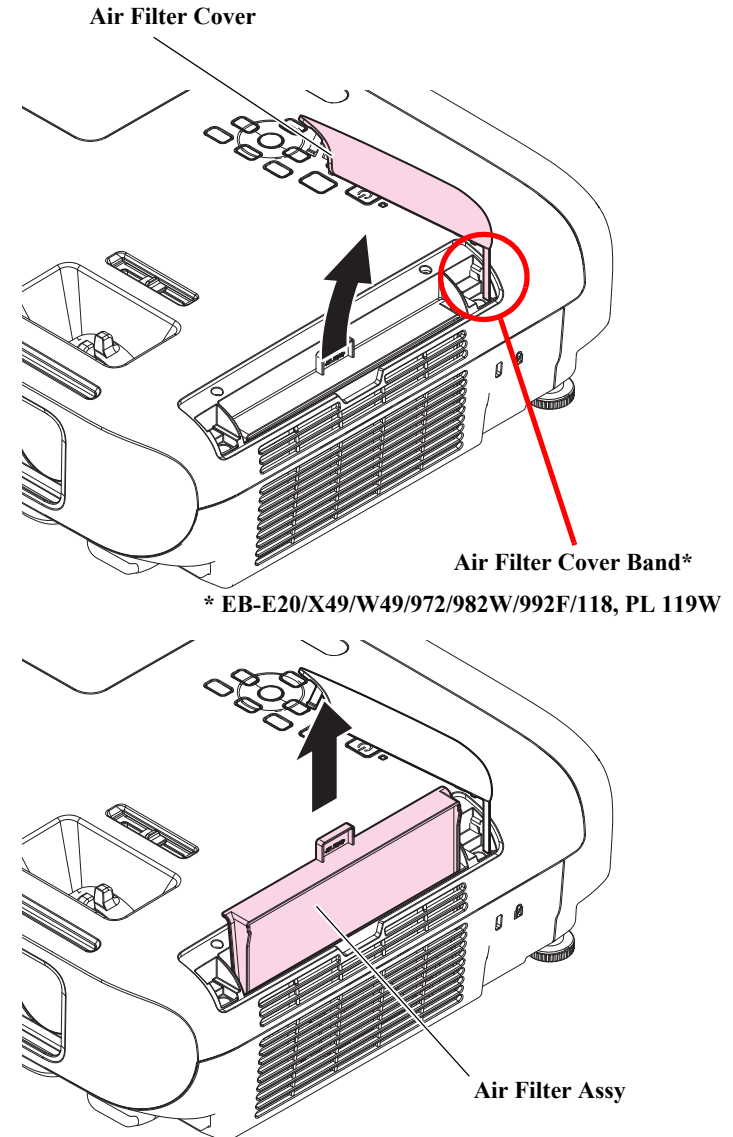

3.3.2 Lamp

DISASSEMBLY PROCEDURE

1. Loosen the screw (○) and remove the "Lamp Cover".
2. Loosen the two screws and remove the "Lamp Assy".

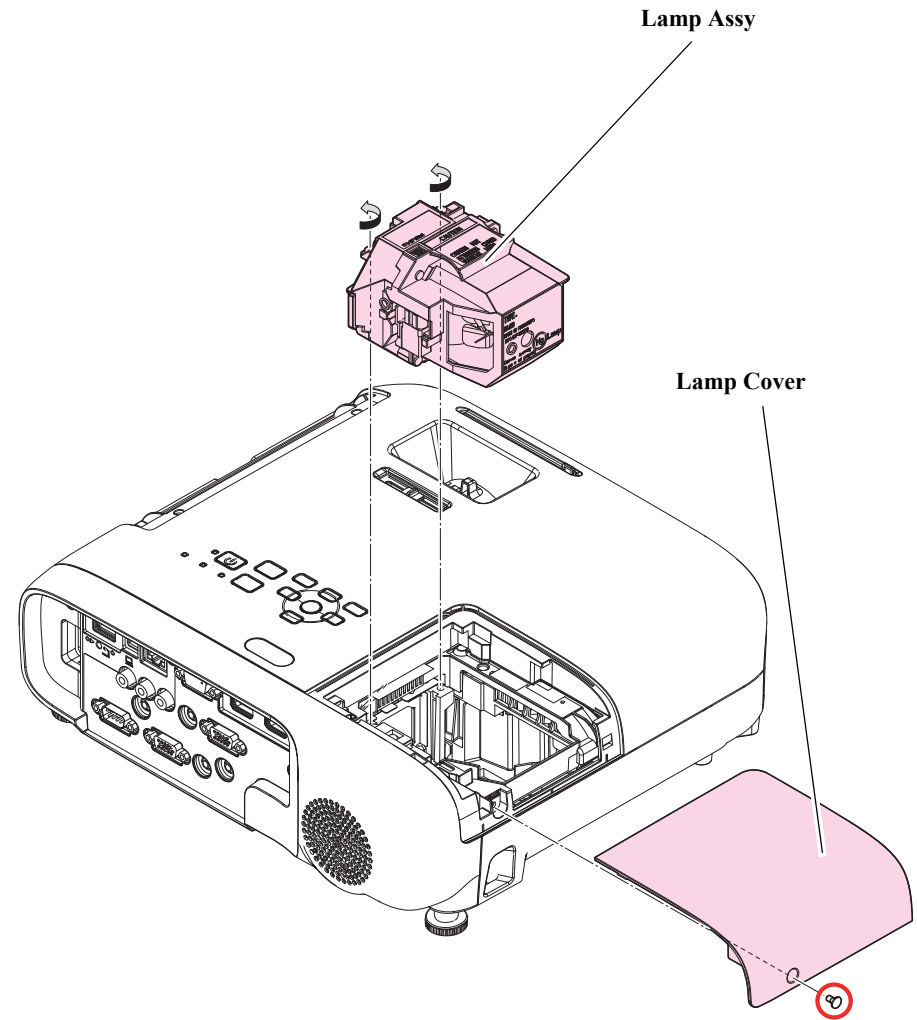

3.3.3 Front Foot

DISASSEMBLY PROCEDURE

1. Insert a flat-head precision screwdriver or tweezers into the grooves on both sides to release the hook.
2. Pull out the "Front Foot" to remove it.

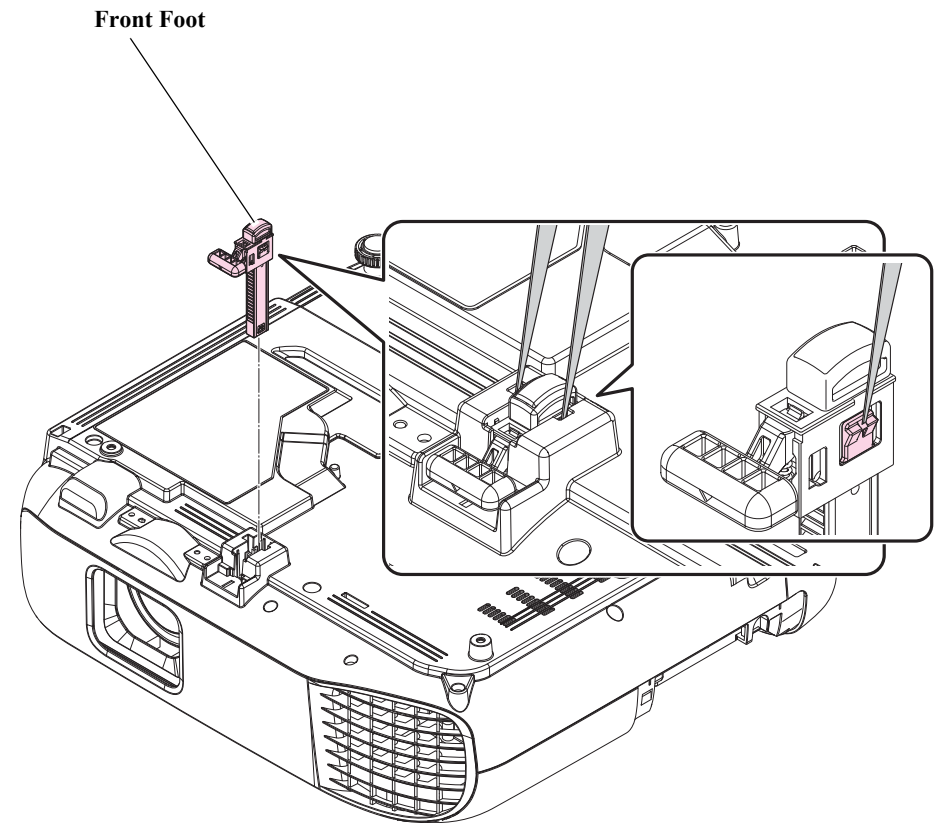

3.3.4 Rear Foot

DISASSEMBLY PROCEDURE

1. Turn the "Rear Foot" counterclockwise fully.
2. Slowly turn the "Rear Foot" until it clicks, and pull it off.
3. Remove the "Foot Rubber" from the "Rear Foot".



Be sure to align the mark on the bottom as shown in below, and pull it off where it clicks.
(To align the groove on the LOWER CASE to prevent two hooks of the screws from damaging.)

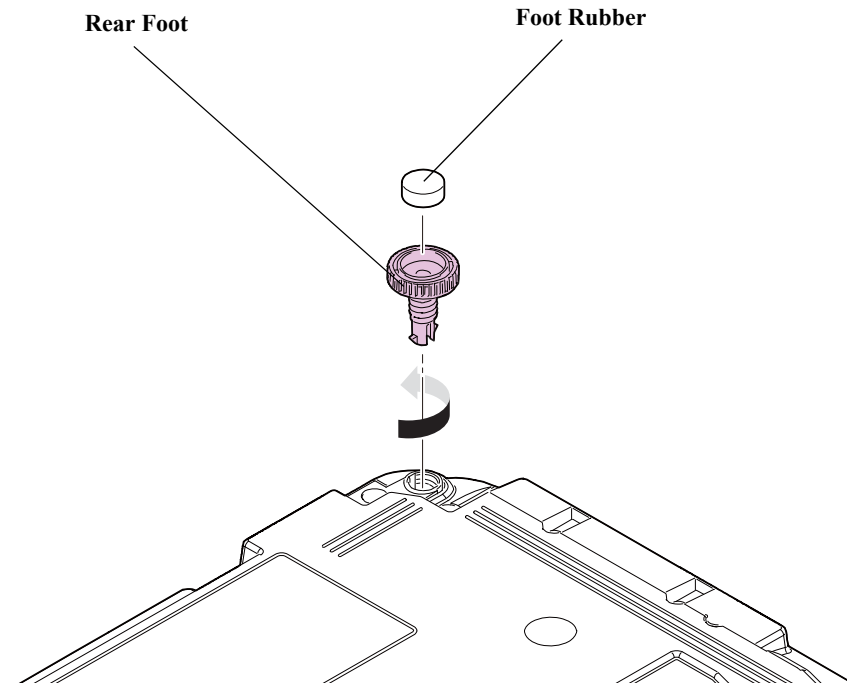
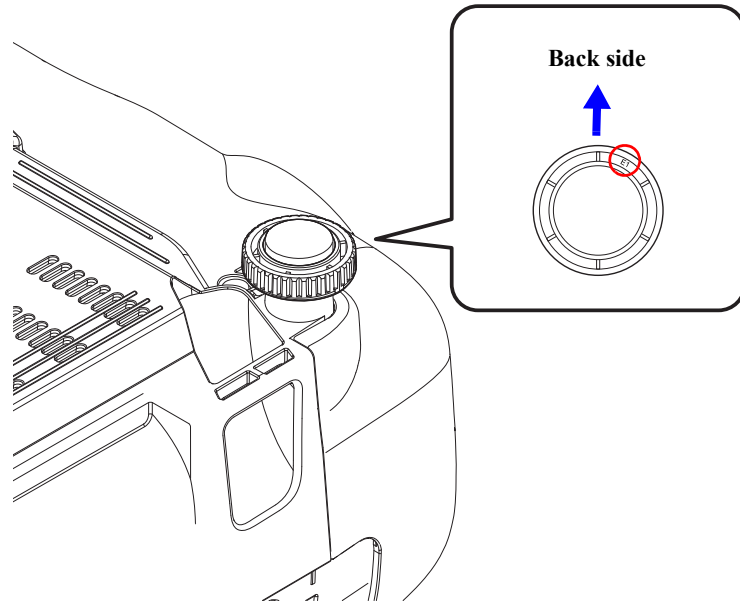





3.3.5 Rear Case

DISASSEMBLY PROCEDURE

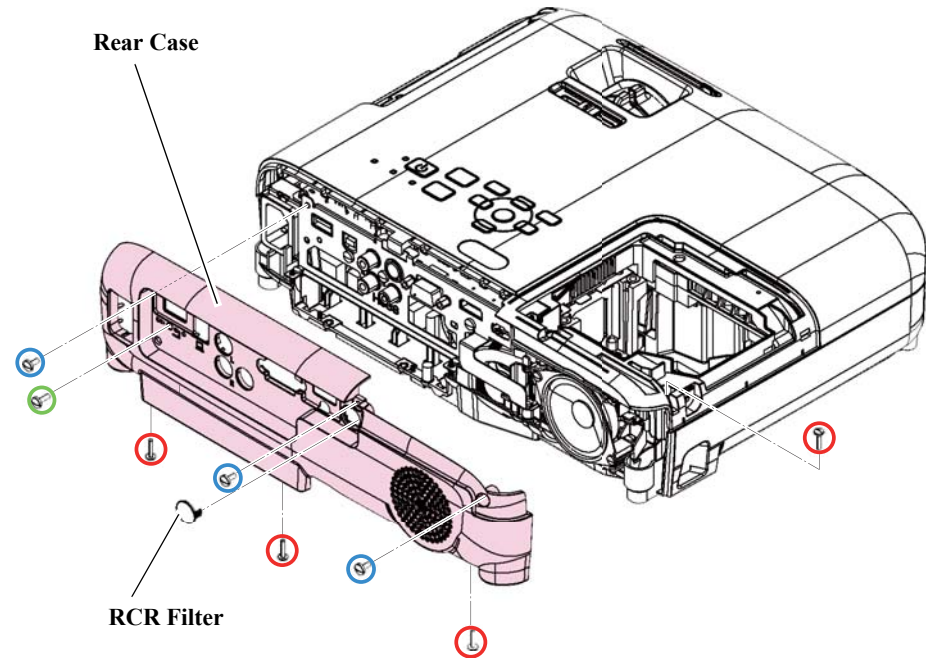
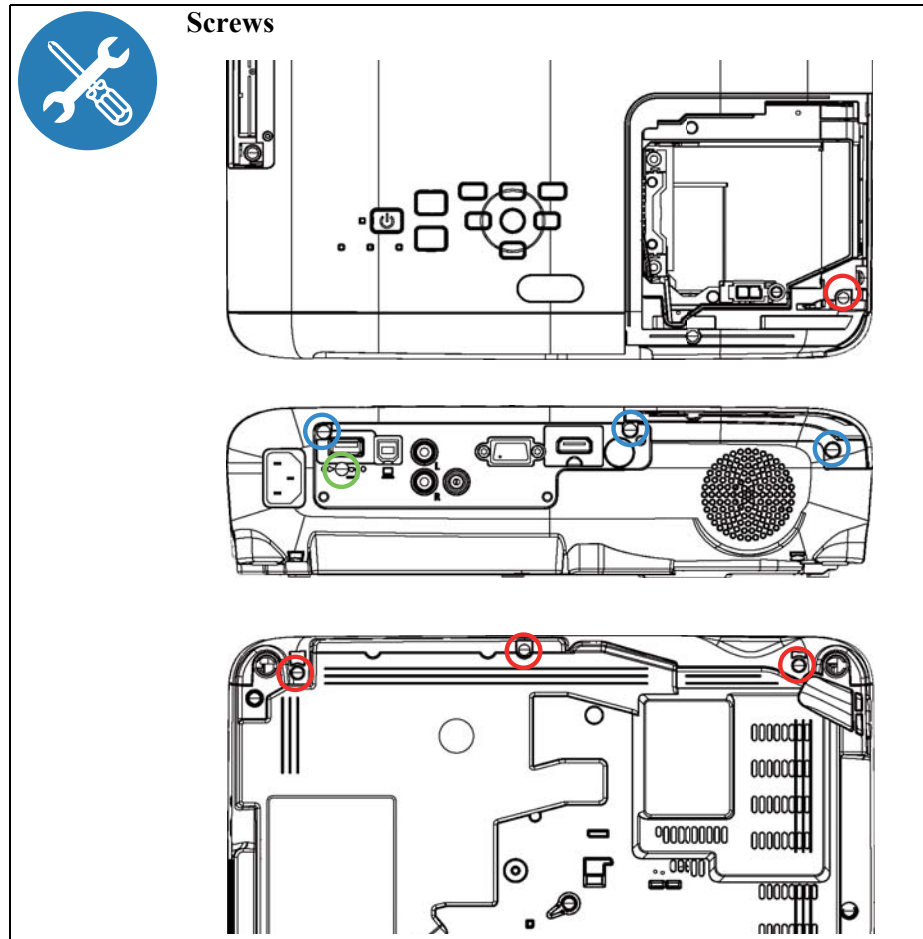
□ EB-E01/X06/W06/E10/X51/W51

1. Remove the four screws (○), the three screws (○) or the one screw (○), and remove the "Rear Case".
2. Remove the "RCR Filter" from the "Rear Case".



	C.B.P-TITE SCREW,2.5X10,F/ZN-3C
	C.B.SCREW,3X6,F/ZB-3C
	C.B.SCREW,3X8,F/NI

□ EB-FH06/FH52/E20/X49/W49/972/982W/992F/118, PL 119W, EH-TW740/TW750

1. Remove the four screws (○), the six screws (○) or the one screw (○), and remove the "Rear Case".
2. Remove the "IF Label" from the "Rear Case".

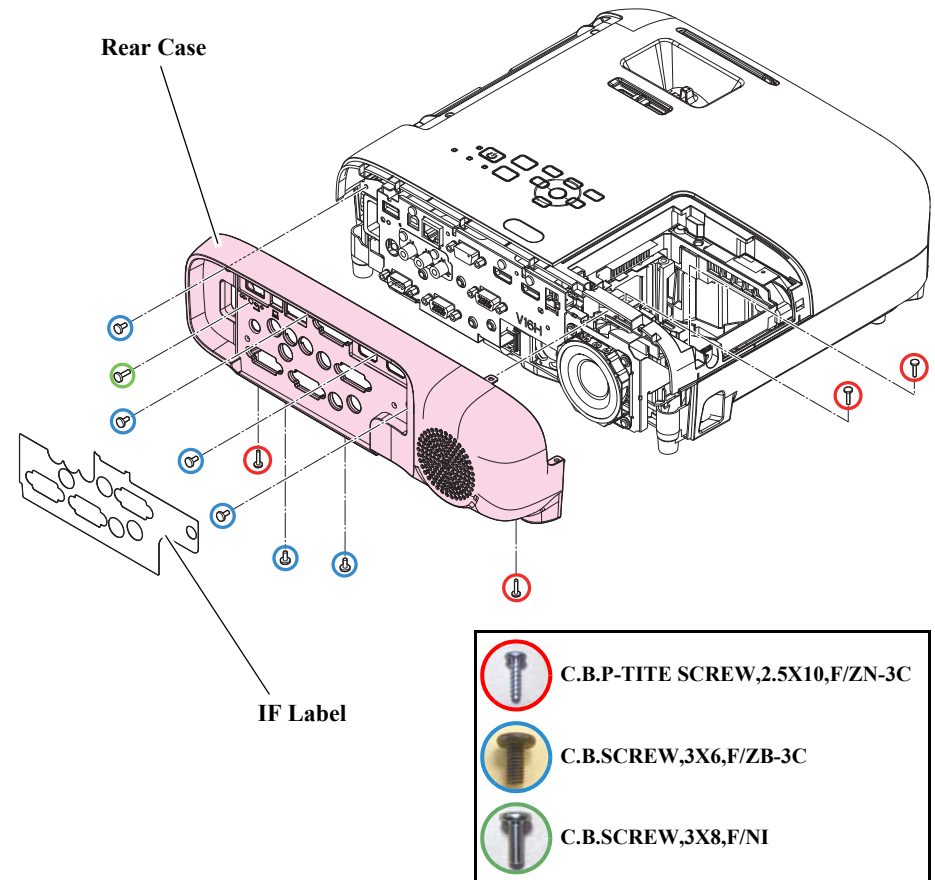
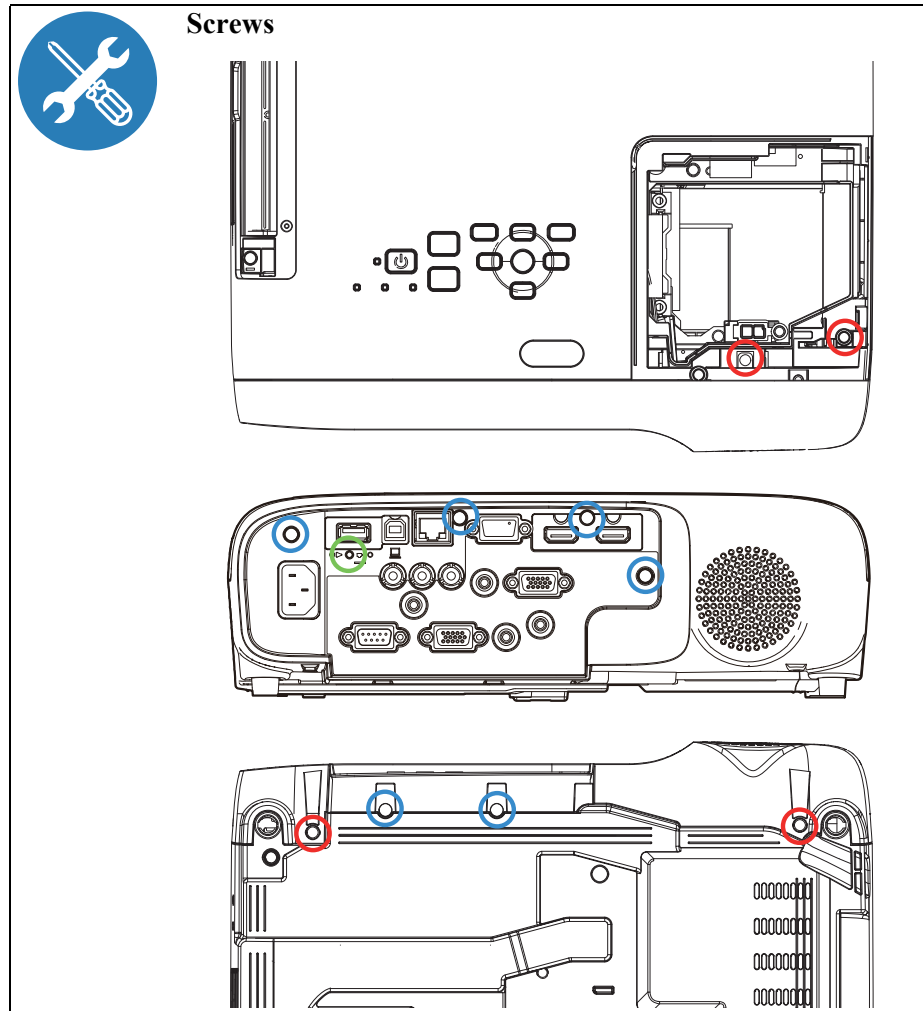

Be careful at the time of assembly, as the two clasps of the "Rear Case" may break.



□ EB-W52

1. Remove the five screws (○) and the two screws (○), and remove the "Rear Case".
2. Remove the "RCR Filter" from the "Rear Case".

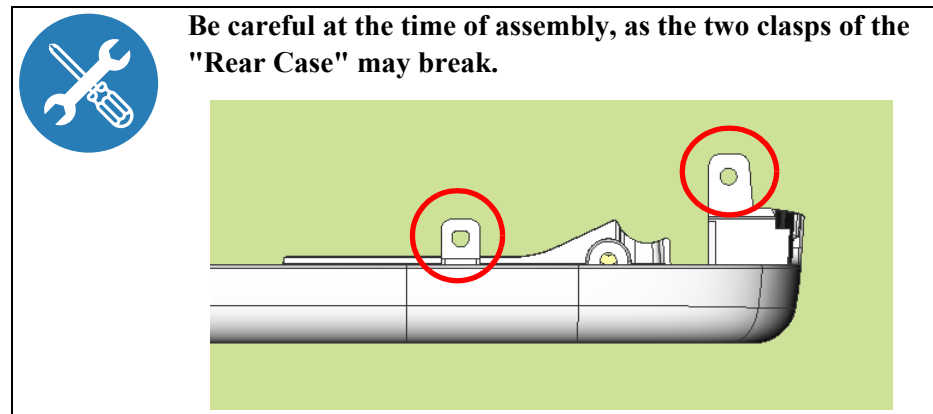
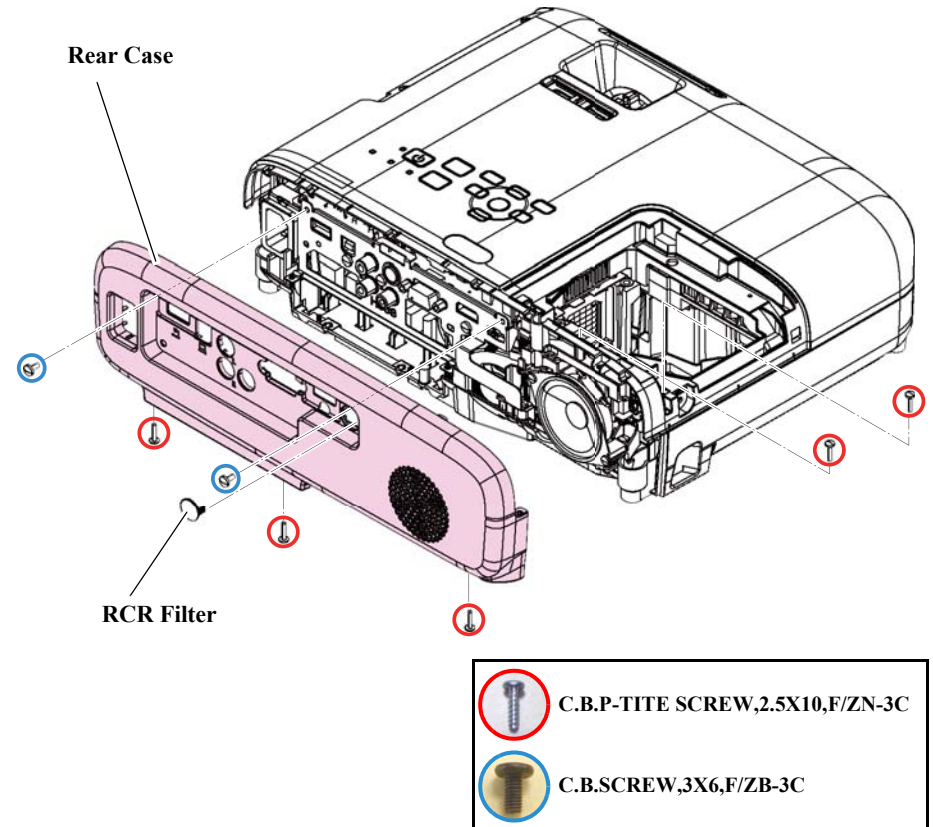
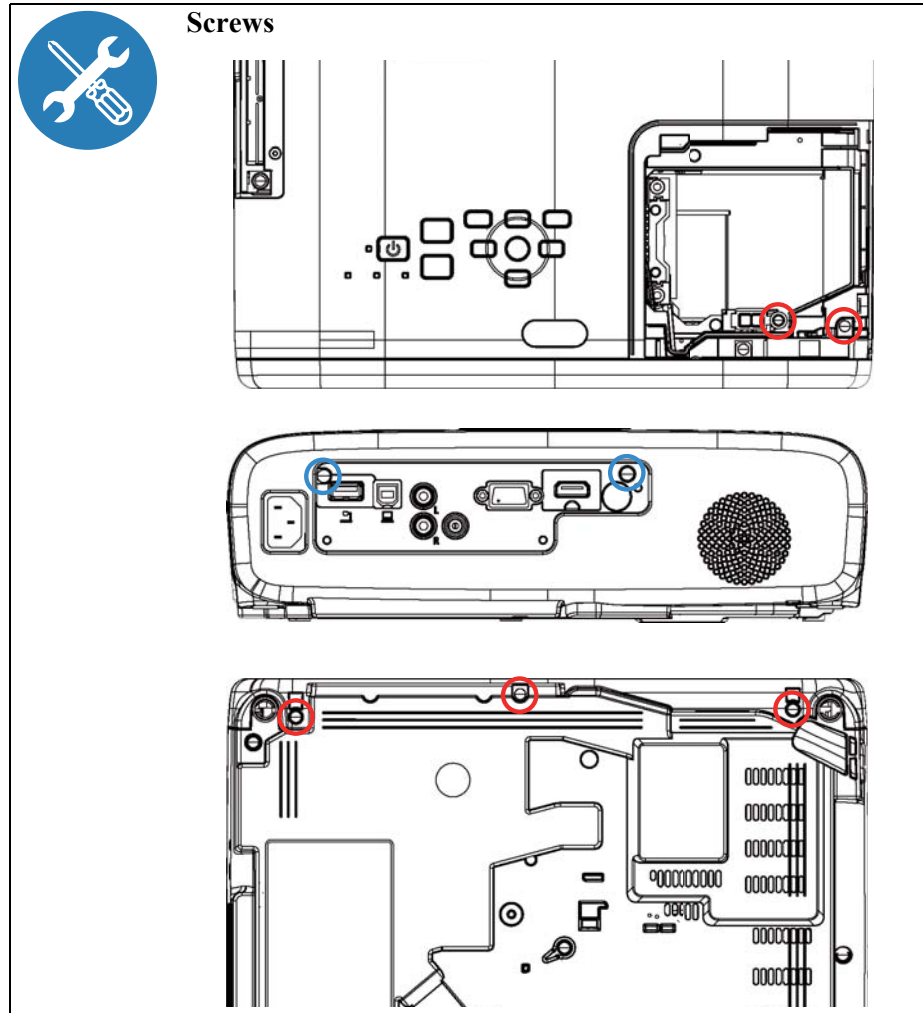

3.3.6 Upper Case (Assy)

DISASSEMBLY PROCEDURE

□ EB-E01/X06/W06/FH06/E10/X51/W51/W52/E20/X49/W49/118,
PL 119W, EH-TW740/TW750

1. See [Flowchart \(p70\)](#) and remove all parts up to the component below from the projector.
[Rear Case \(p77\)](#)
2. Remove the six screws (○) on the bottom.

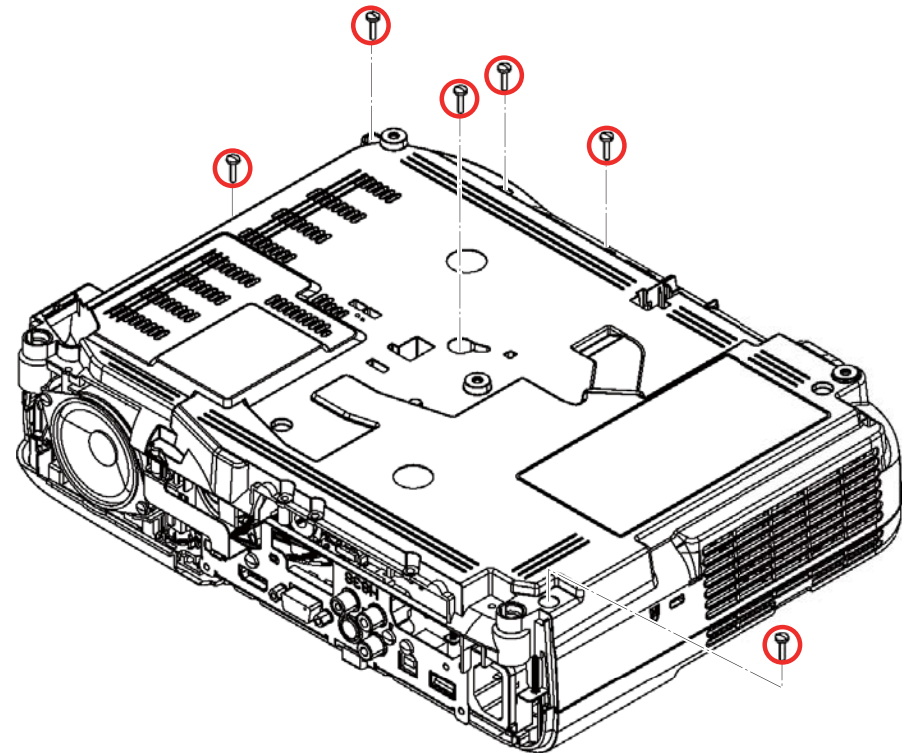
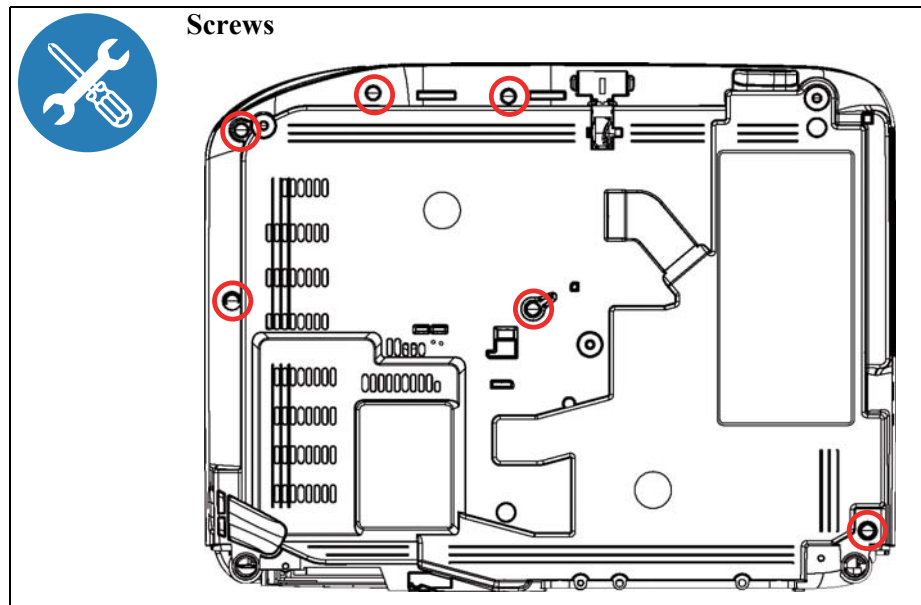



- Remove the three (four) screws (○/○) from the top.
(EB-118 and PL 119W have the ○ screws)

 **Be careful as the FFC "SW Cable" is connected to the switch board on the INT Duct side of the main unit.**

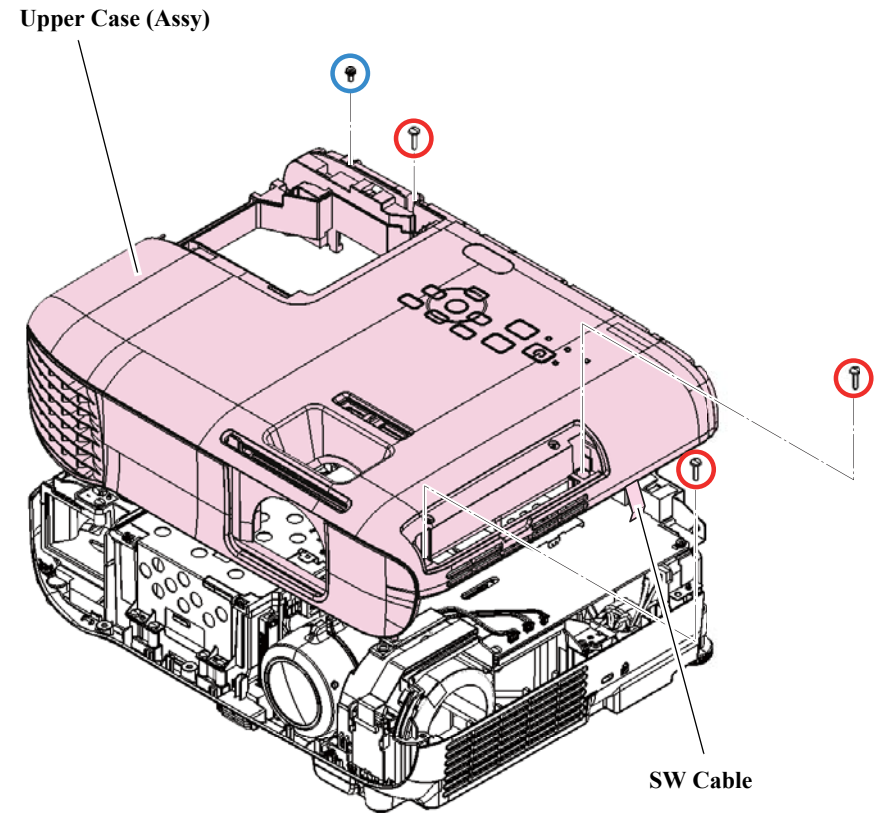
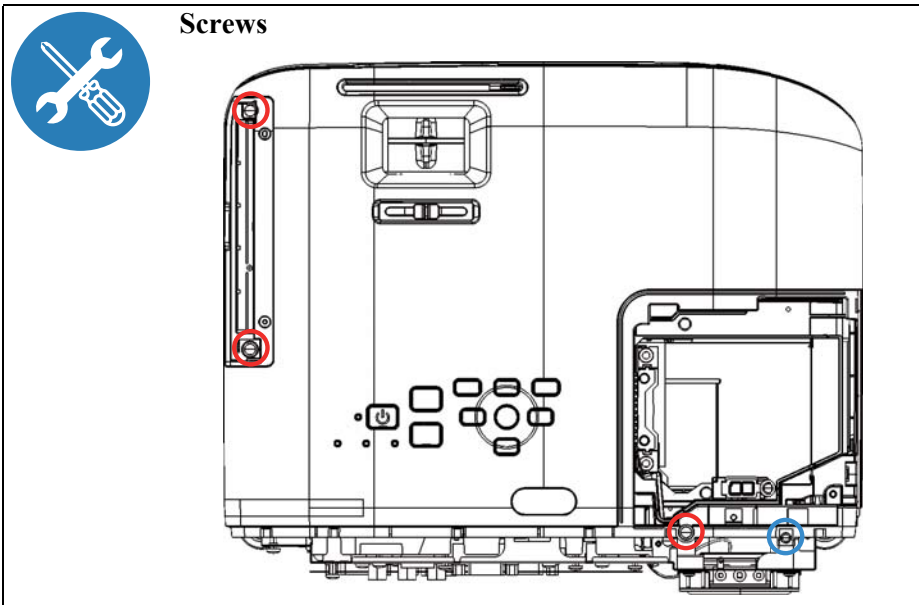
- Remove the FFC, and then remove the "Upper Case (Assy)".
(See *How to unlock connectors for FFC/FPC (p67)*)



	C.B.P-TITE SCREW,2.5X10,F/ZN-3C
	C.P.(S-P1)SCREW,2.5X6,F/ZN-3C

□ EB-FH52/972/982W/992F

1. See *Flowchart (p70)* and remove all parts up to the component below from the projector.
Rear Case (p77)
2. Remove the seven screws (○) on the bottom.

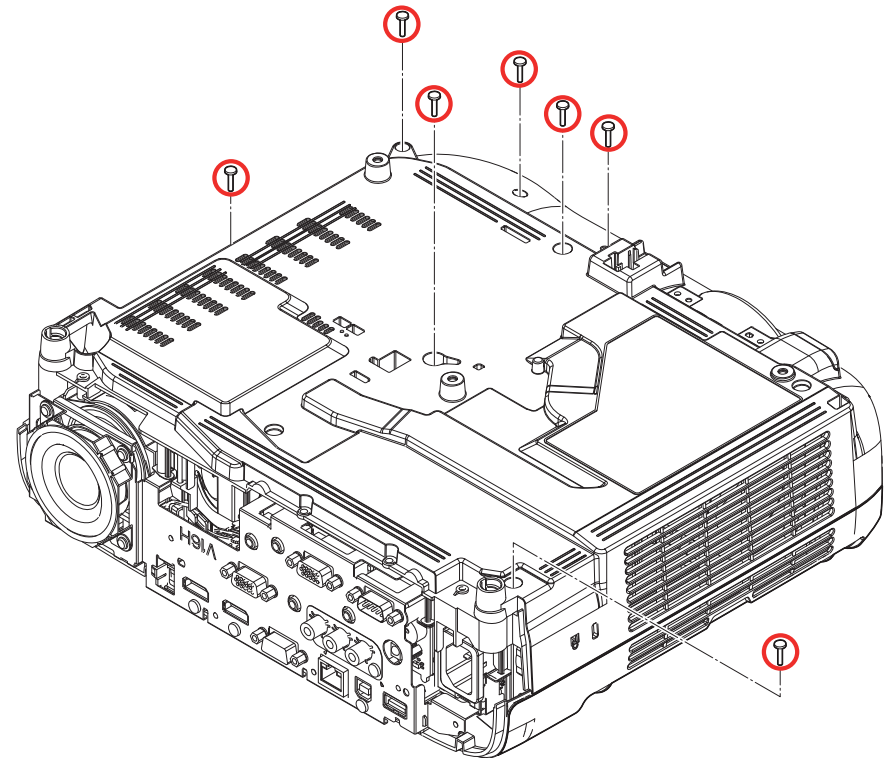
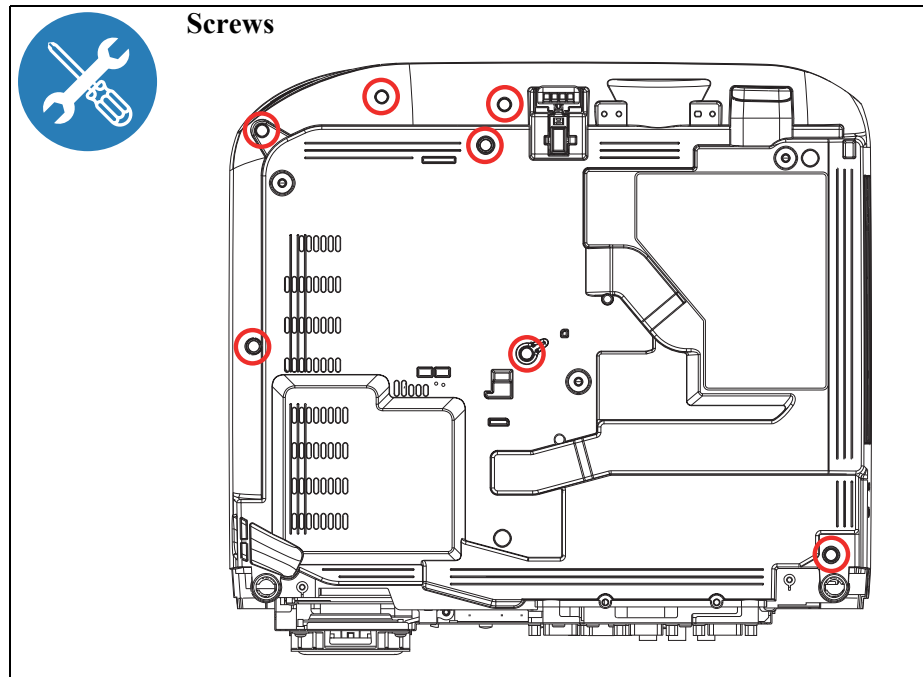



- Remove the four screws (○/○) from the top.

 **Be careful as the FFC "SW Cable" is connected to the switch board on the INT Duct side of the main unit.**

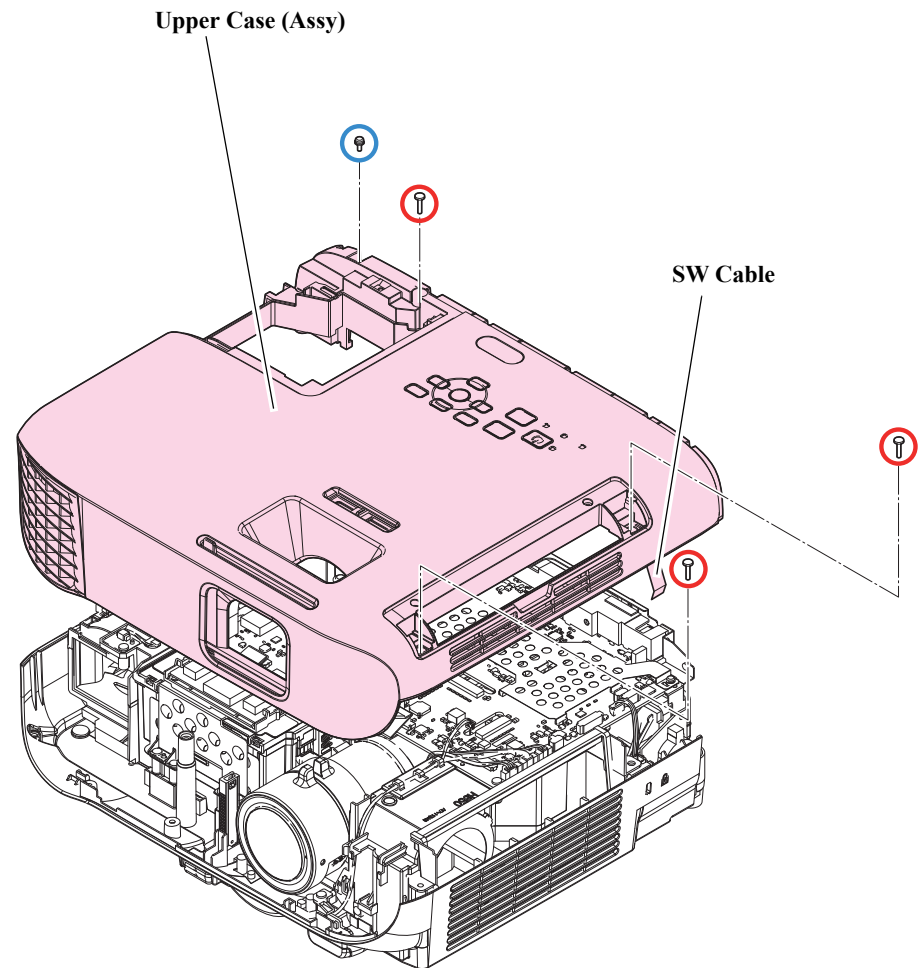
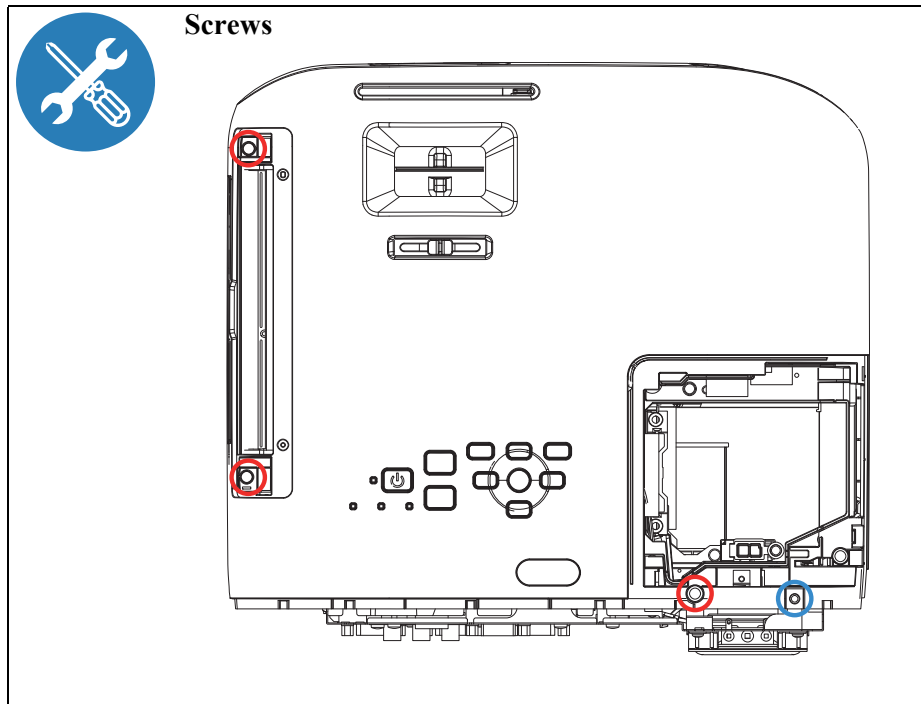
- Remove the FFC, and then remove the "Upper Case (Assy)".
(See *How to unlock connectors for FFC/FPC* (p67))



	C.B.P-TITE SCREW,2.5X10,F/ZN-3C
	C.P.(S-P1)SCREW,2.5X6,F/ZN-3C

3.3.6.1 SW Board

DISASSEMBLY PROCEDURE

1. See *Flowchart (p70)* and remove all parts up to the component below from the projector.
Upper Case (Assy) (p80)
2. Remove the five screws (○) and remove the "SW Board".
3. Remove the connector of the connected cable.
4. Remove the following parts:
 - SW Cable
(See *How to unlock connectors for FFC/FPC (p67)*)
 - LED Lens
 - SW Button
 - Power Button



When attaching the "SW Board", fasten the screws in the order shown below.

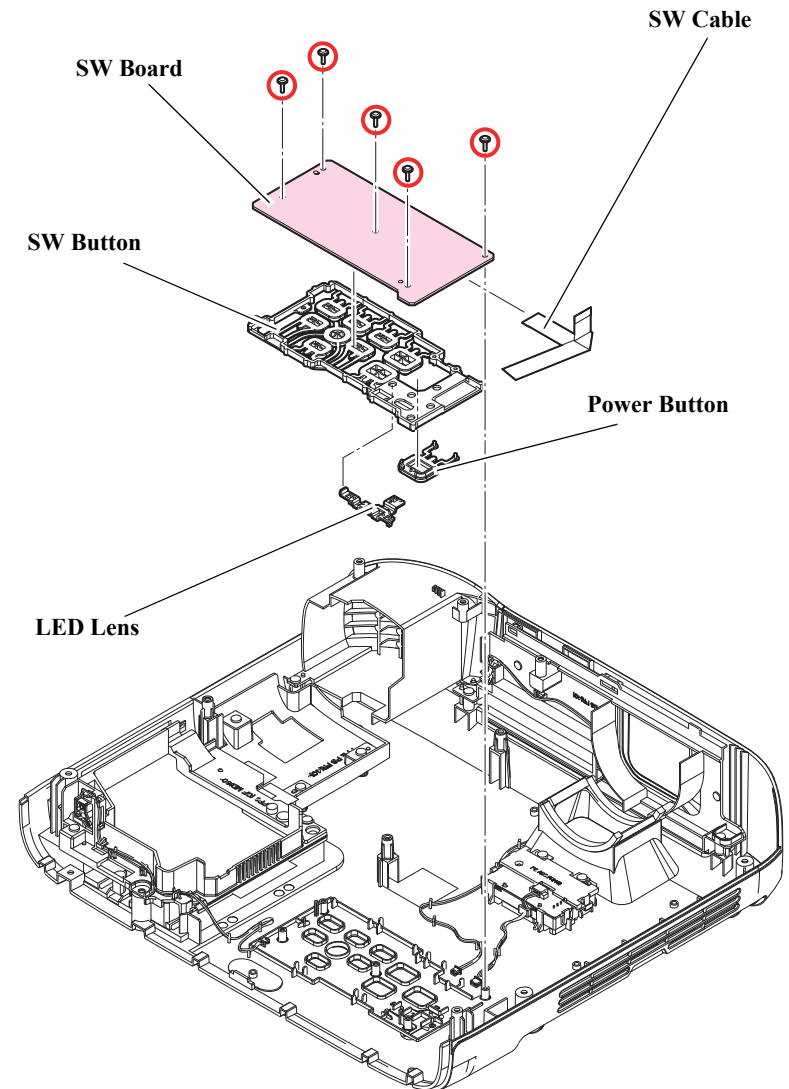
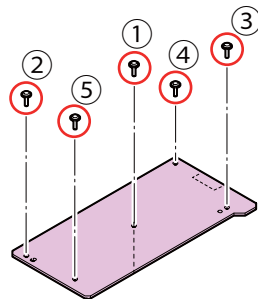

C.C.P-TITE SCREW,2X6.5,F/ZB-3C

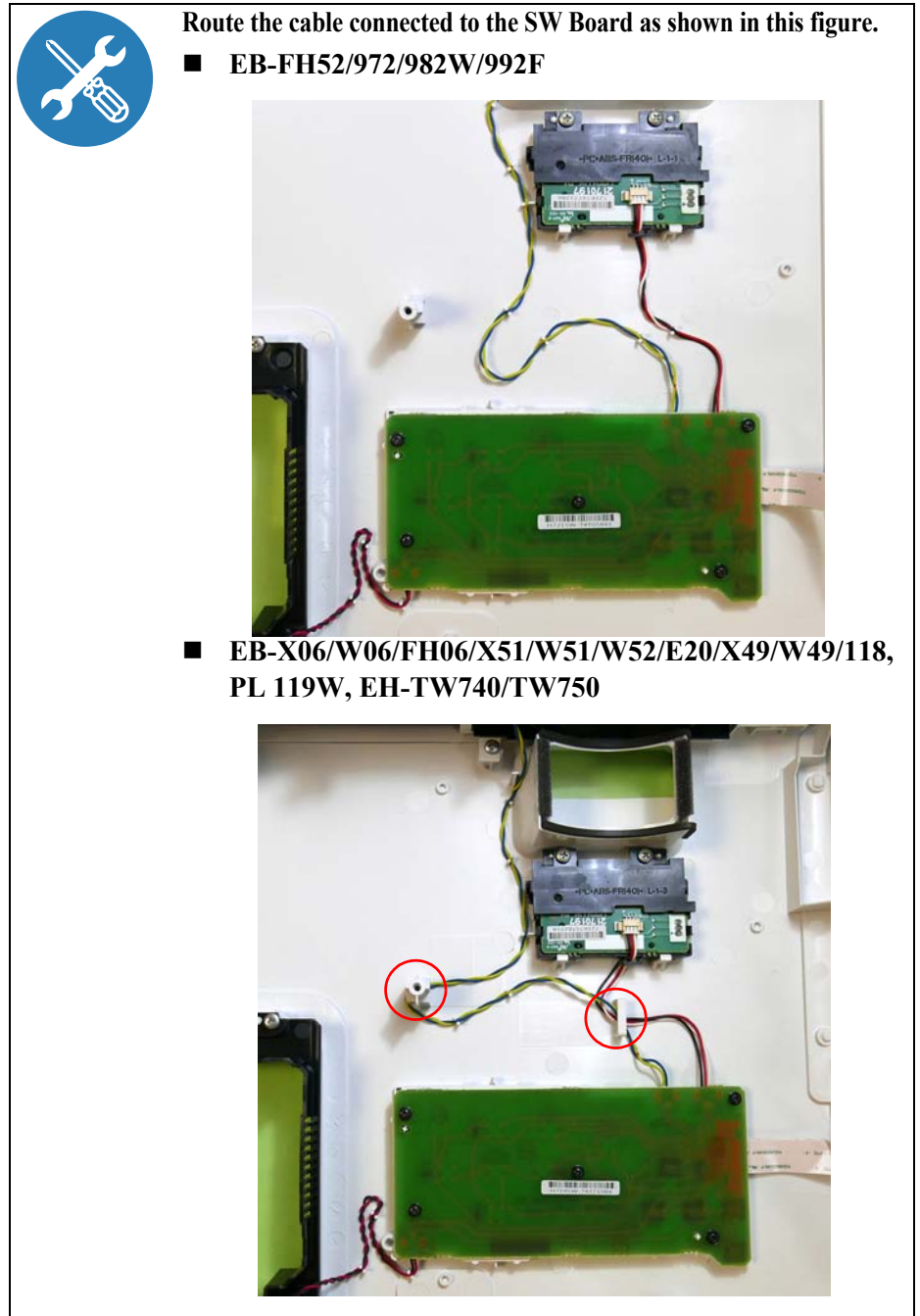
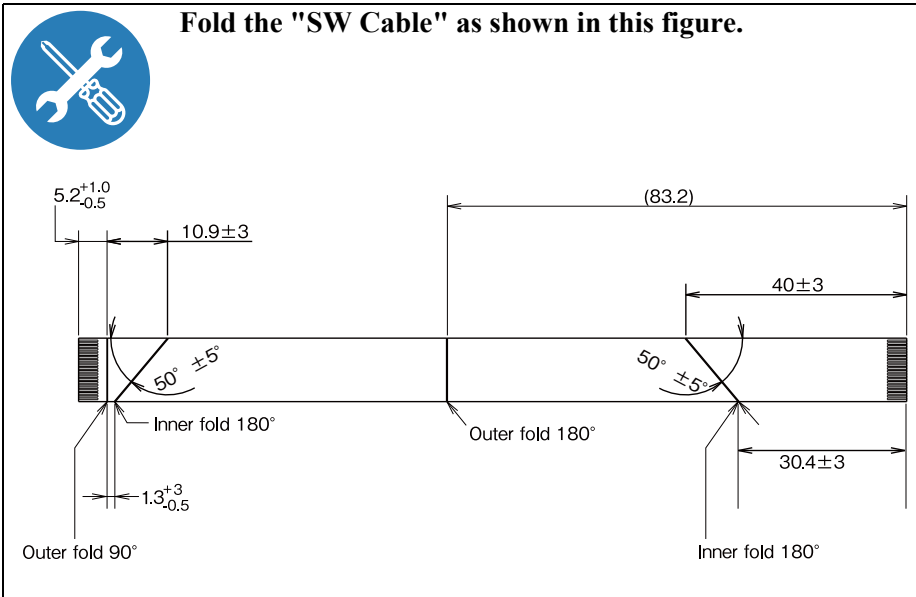

3.3.6.2 H Key Assy/Upper Case

DISASSEMBLY PROCEDURE

1. See *Flowchart (p70)* and remove all parts up to the component below from the projector.
Upper Case (Assy) (p80)
2. Remove the two screws (○) and remove the "H Key Assy".
(This procedure is not applicable to EB-E01/E10.)
3. Remove the two screws (○) and remove the "Upper Case Cover".
4. Remove the screw (○) and remove the "Lid Lamp Switch".
5. Remove the following parts:
 - Nut Plate M3 x1 (2 pcs)

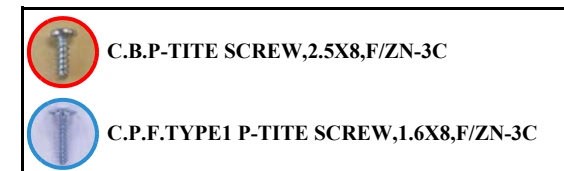
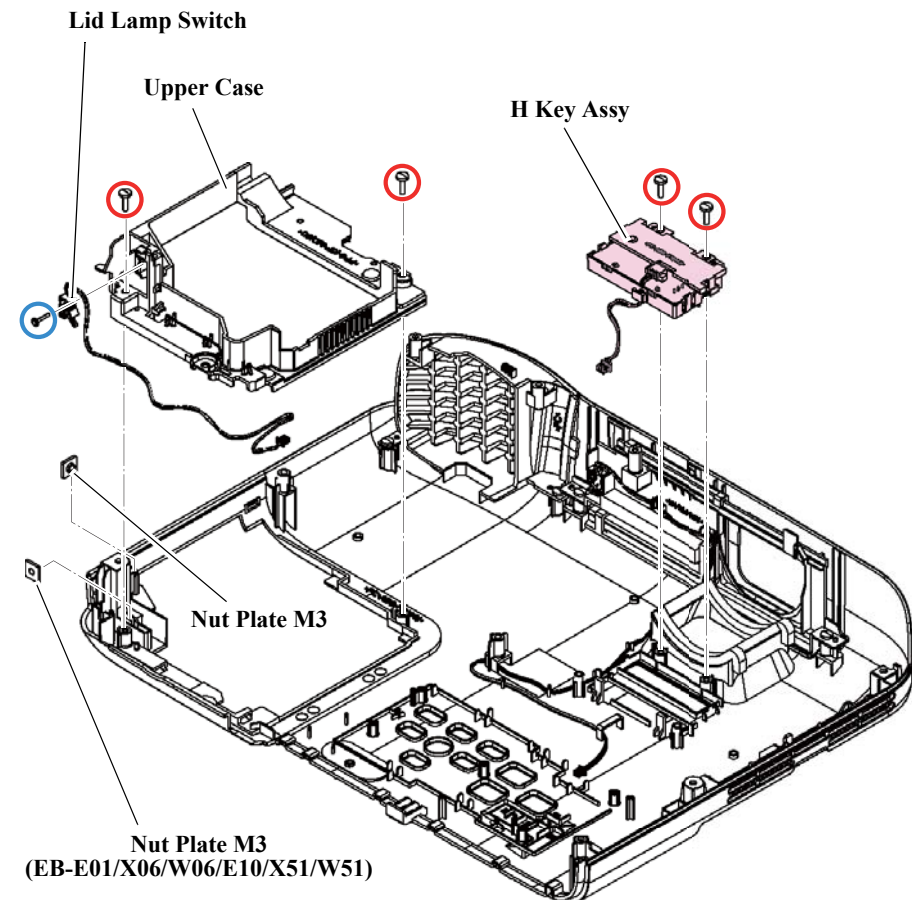
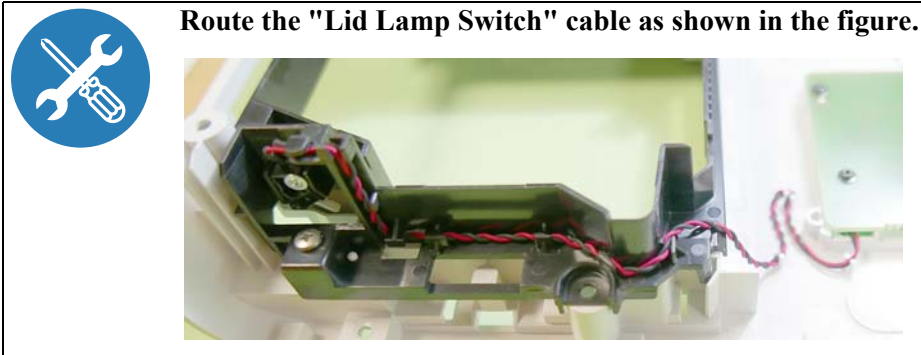

3.3.6.3 Shutter

DISASSEMBLY PROCEDURE

1. See *Flowchart (p70)* and remove all parts up to the component below from the projector.
Upper Case (Assy) (p80)
2. Remove the two screws (○) and remove the "Shutter (Assy)".
(The following procedure does not apply to EB-E01/E10.)
3. Remove the screw (○) and remove the "Switch Cable H721-A".
4. Remove the following parts:
 - Shutter frame
 - Shutter ball
 - Shutter Spring
 - Lens Shutter
 - Shutter Lens Sheet

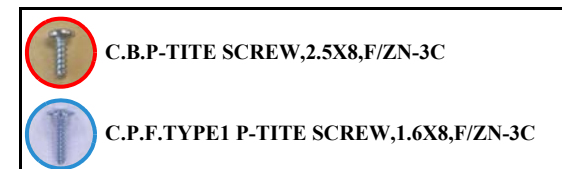
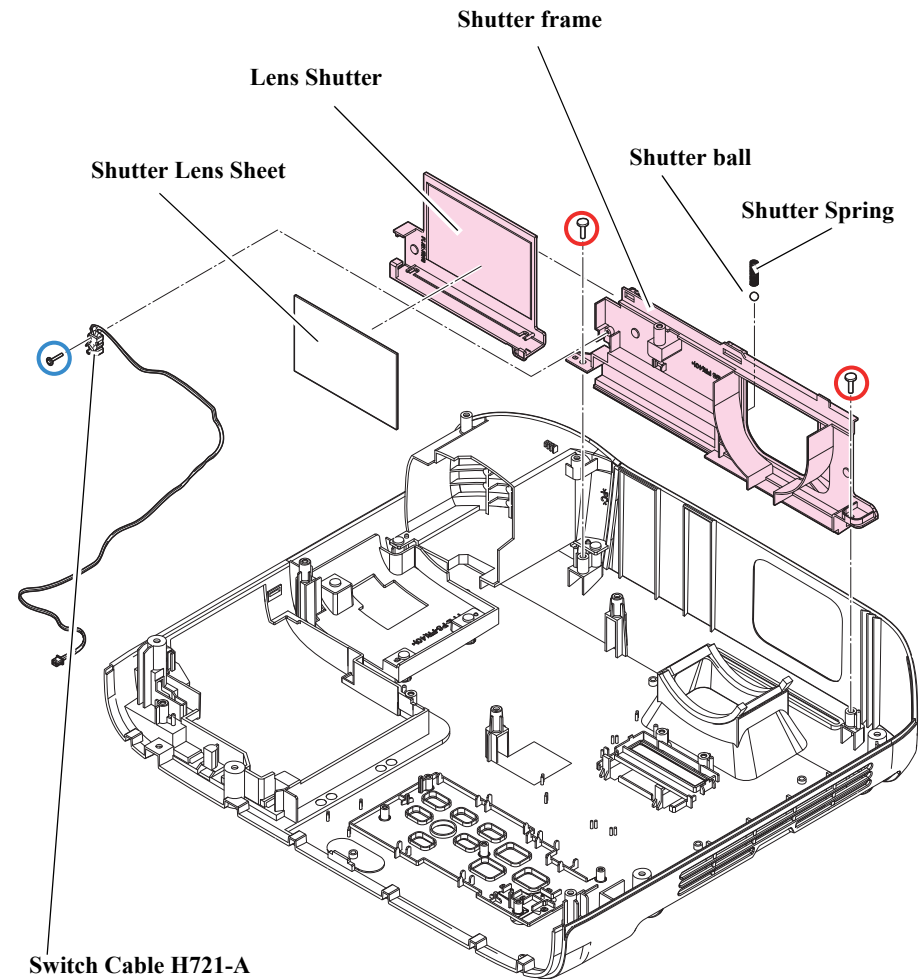



Route the "Switch Cable H721-A" as shown in the figure.

■ EB-FH52/972/982W/992F

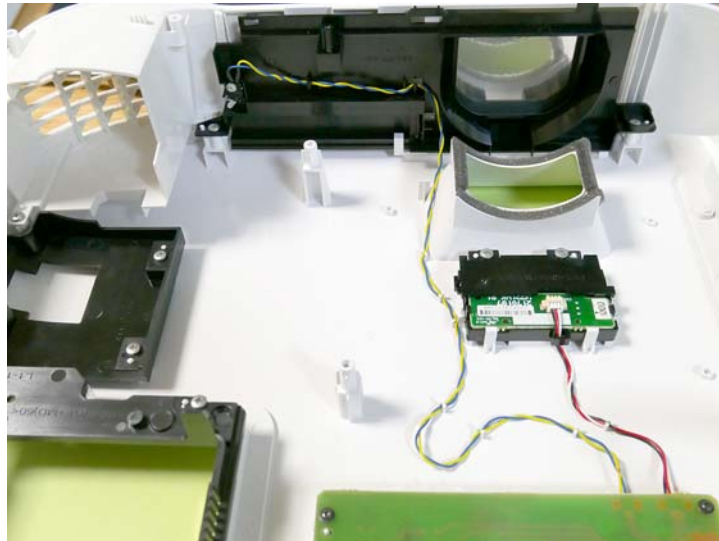

■ EB-X06/W06/FH06/X51/W51/W52/E20/X49/W49/118,
PL 119W, EH-TW740/TW750

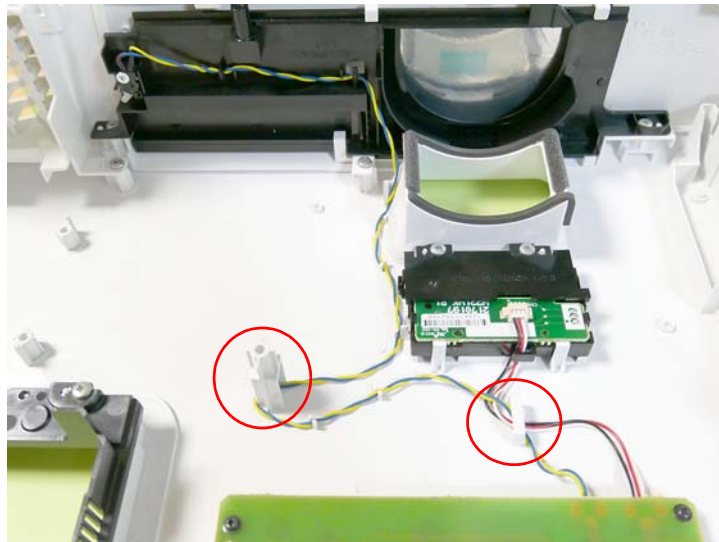

3.3.6.4 Upper Case

DISASSEMBLY PROCEDURE

See *Flowchart (p70)* and remove all parts up to the component below from the projector.

Shutter (p87)

□ A: EB-E01/X06/W06/E10

1. Remove the two screws (○) and remove the "EX Case".
2. Remove the following parts from the "Upper Case".
 - Upper Cushion A x2 pcs
 - Upper Cushion B x2 pcs

□ B: EB-X51/W51

1. Remove the three screws (○) and remove the "Front Case" and the "EX Case".
2. Remove the following parts from the "Upper Case".
 - Upper Cushion A x2 pcs
 - Upper Cushion B x2 pcs

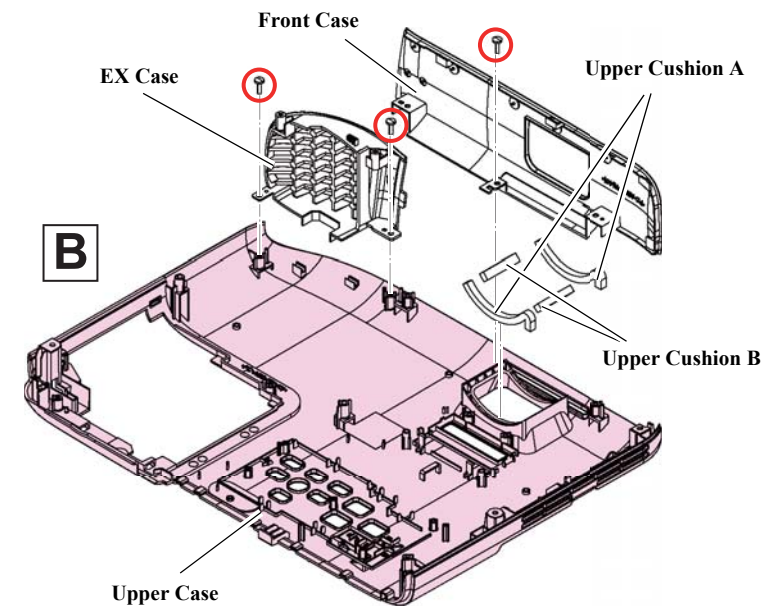
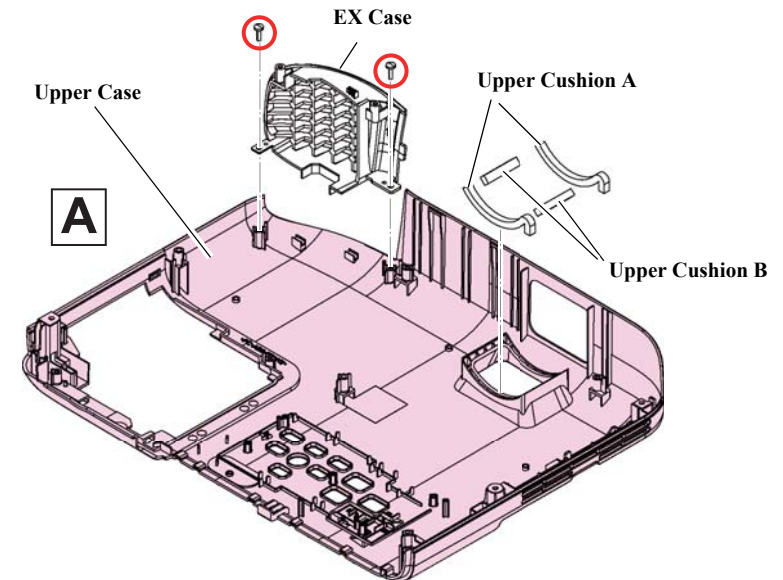

□ C: EB-972/982W

1. Remove the five screws (○) and remove the "EX Case" and the "Upper Case Inner".
2. Remove the following parts from the "Upper Case".
 - Upper Cushion A x2 pcs
 - Upper Cushion B x2 pcs
 - Sheet Upper A x2 pcs
 - Sheet Upper H854
 - Sheet Lid Lamp

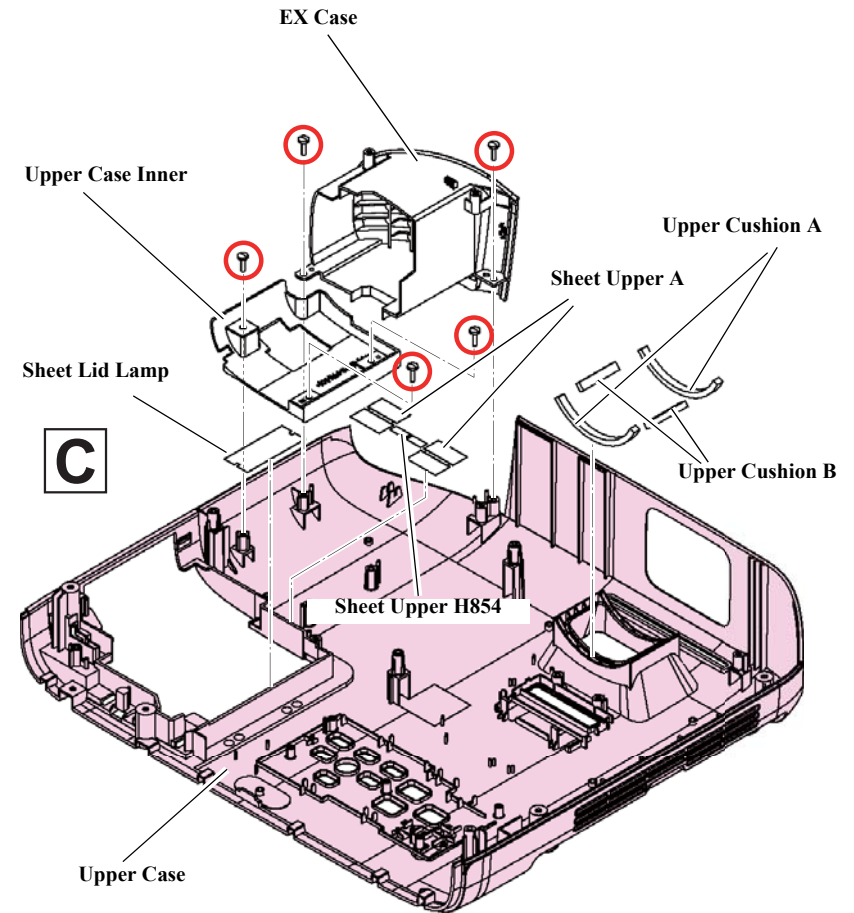

□ D: EB-FH52/992F

1. Remove the six screws (○) and remove the "EX Case", the "Front Case" and the "Upper Case Inner".
2. Remove the following parts from the "Upper Case".
 - Upper Cushion A x2 pcs
 - Upper Cushion B x2 pcs
 - Sheet Upper A x2 pcs
 - Sheet Upper H854
 - Sheet Lid Lamp

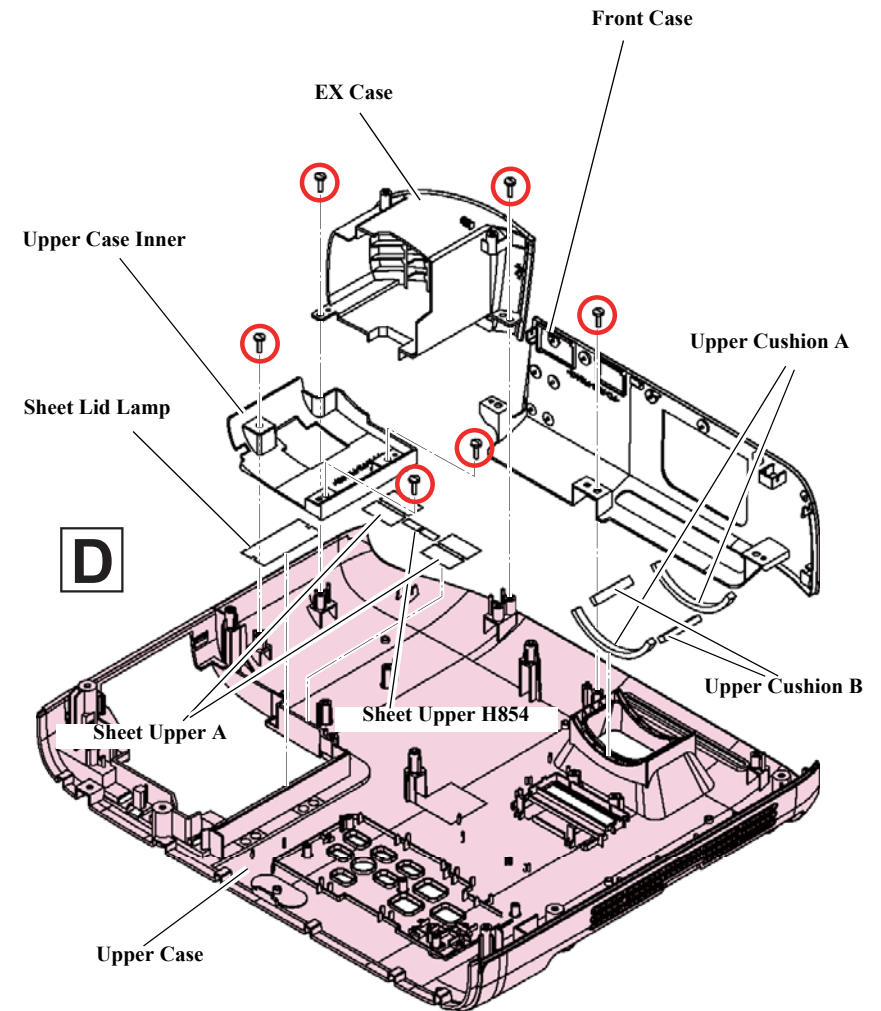

□ E: EB-FH06/E20/X49/W49/W52/118, PL 119W, EH-TW740

1. Remove the three screws (○) and remove the "EX Case" and the "Front Case".
2. Remove the following parts from the "Upper Case".
 - Upper Cushion A x2 pcs
 - Upper Cushion B x2 pcs

□ F: EH-TW750

1. Remove the three screws (○) and remove the "EX Case" and the "Front Case".
2. Remove the following parts from the "Upper Case".
 - Upper Cushion A-H722
 - Upper Cushion B x2 pcs

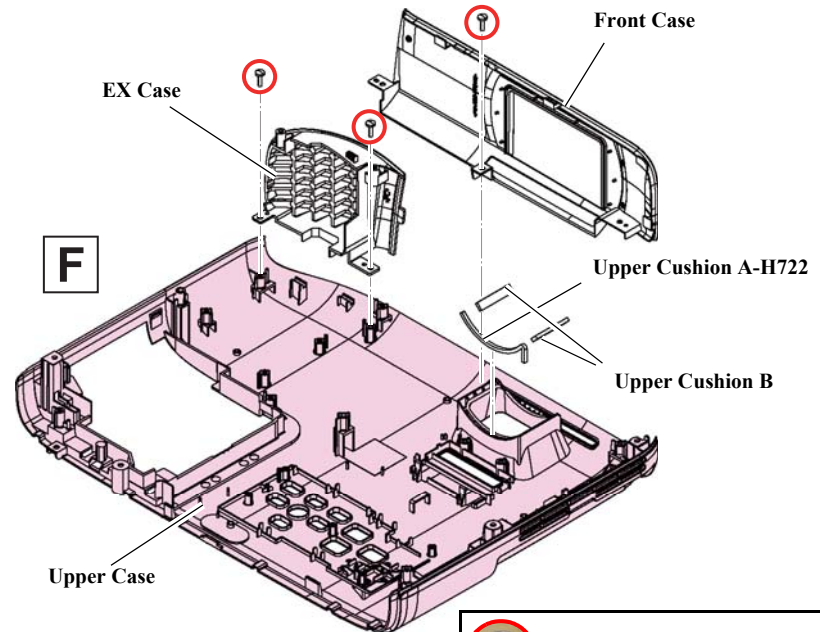
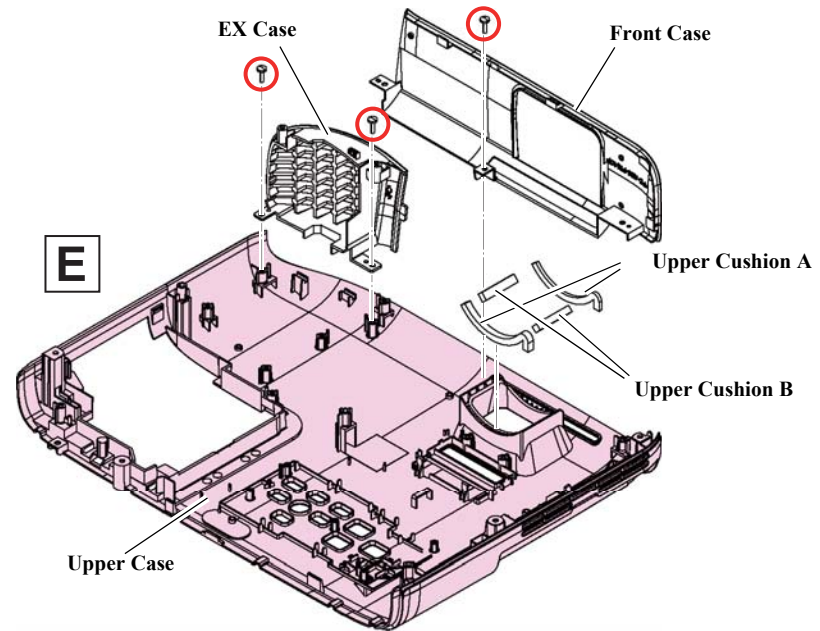



Replacing the Caution Label Sheet

The Upper Case of ASP does not have Safety Device labels as shown below. When replacing the Upper Case, peel off the labels and stick them to the new Upper Case.

Caution Label Part A

Caution Label Part B

Caution Label Part C

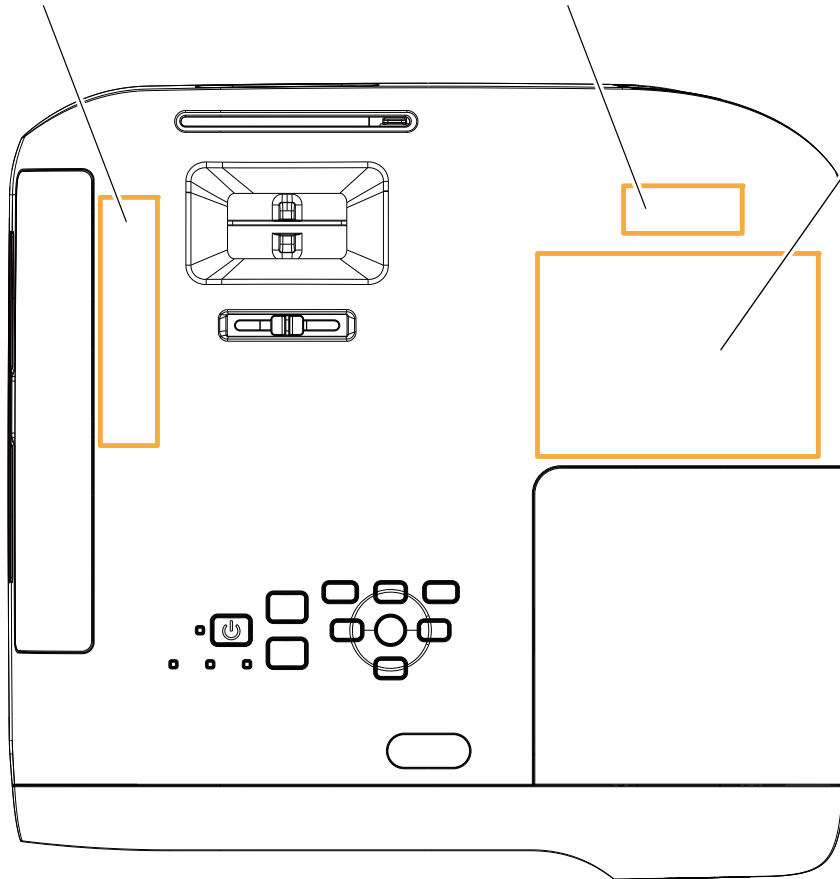

3.3.7 WFD Board

DISASSEMBLY PROCEDURE

□ EB-FH52/992F, EH-TW750

1. See *Flowchart (p70)* and remove all parts up to the component below from the projector.
Upper Case (Assy) (p80)
2. Remove the "FFC 30P" and the "FFC WFD-MA" from the connector.
(See How to unlock connectors for FFC/FPC (p67))
3. Remove the "M-CUSHION H1W10L17" and the "M-CUSHION H1W4L19".
4. Remove the four screws (○) and remove the "WFD Board" and the "WFD Shield Plate".
5. Remove the following parts:
 - M-CUSHION H1W3L29
 - M-CUSHION H1W3L39
 - M-CUSHION H1W3L54

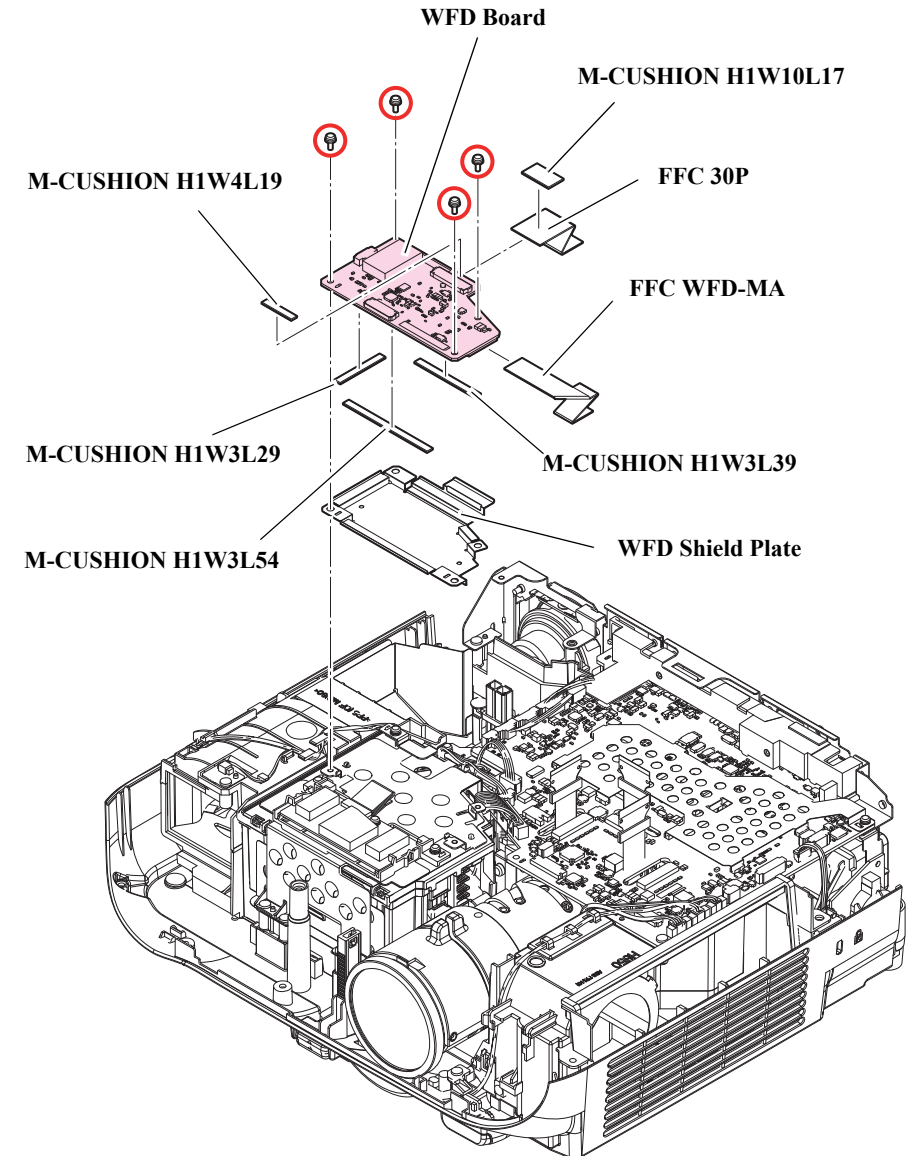



Fold the "FFC 30P" as shown in this figure.

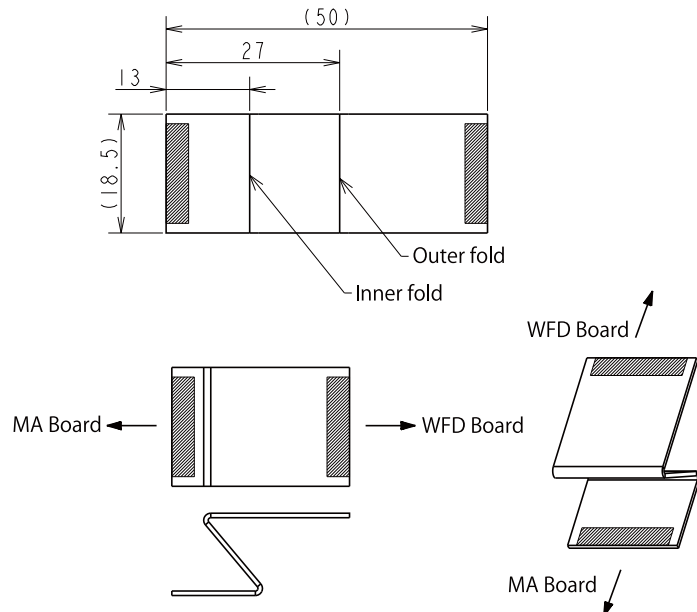

Fold the "FFC WFD-MA" as shown in this figure.

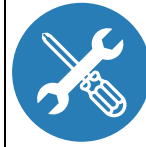
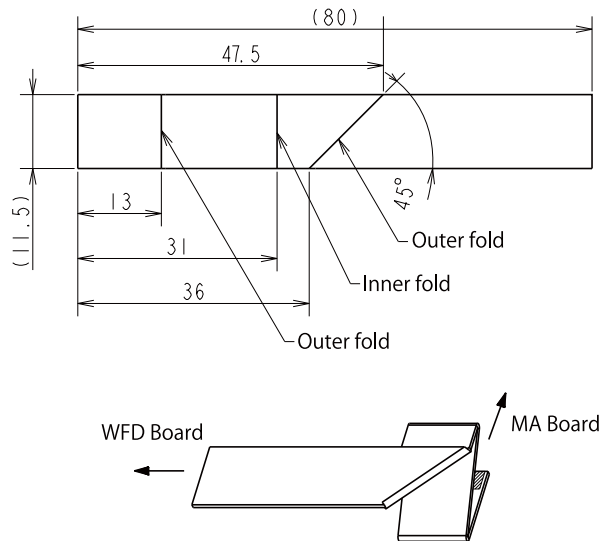

Affix each "M-CUSHION" to the positions shown in the figure.

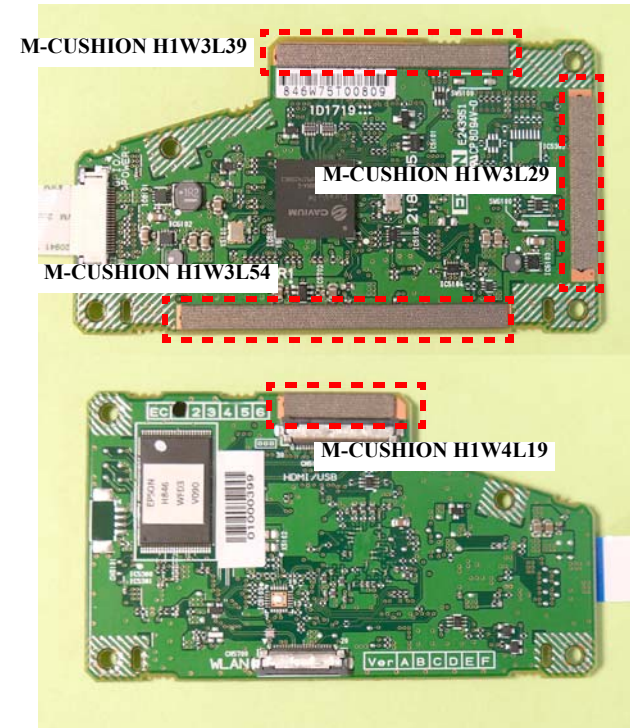

3.3.8 P3dash Module

DISASSEMBLY PROCEDURE

□ EB-FH52/992F, EH-TW750

1. See *Flowchart (p70)* and remove all parts up to the component below from the projector.
Upper Case (Assy) (p80)
2. Remove the "FFC WFD-WRF" from the connectors on both ends.
(See How to unlock connectors for FFC/FPC (p67))
3. Remove the three screws (○) and remove the "P3dash Module" and the "WRF Holder".

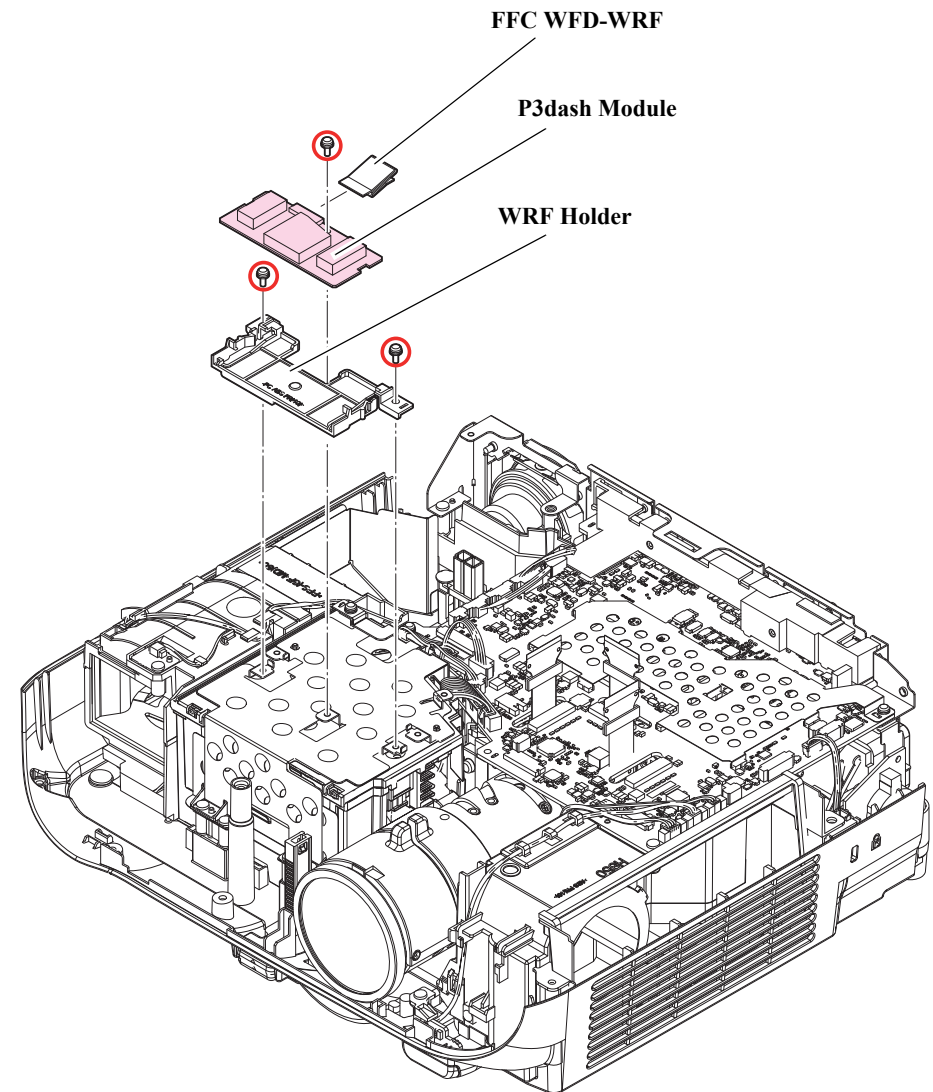
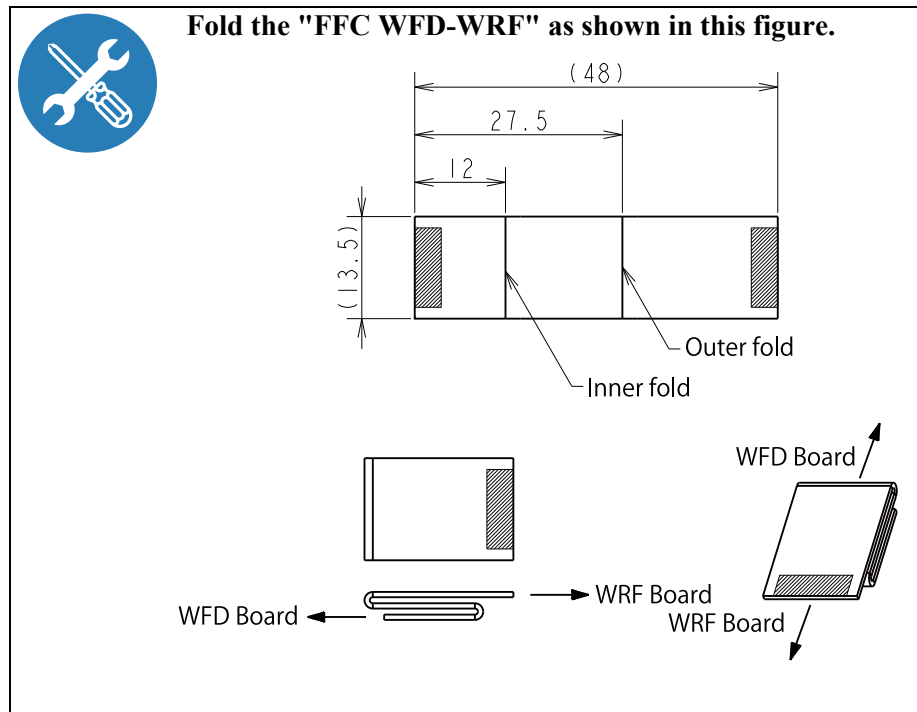

3.3.9 RTC Board

DISASSEMBLY PROCEDURE

□ EB-FH52/992F

1. See [Flowchart \(p70\)](#) and remove all parts up to the component below from the projector.
[Upper Case \(Assy\) \(p80\)](#)
2. Remove the "RTC Cable H854" from the connector.
3. Remove the "RTC Board".
4. Remove the "Lithium Battery" from the "RTC Board".



After removing the RTC Board, place it on the insulator. If the Lithium Battery is already inserted, the RTC Board may short.



When replacing the "RTC Board" for repair, be sure to execute the following:

- The information such as the time of first boot, and the time of lamp replacement for this machine is recorded in the memory on the MA Board. The user may need this information for the purpose of operation and management of this machine; therefore, when the "RTC Board" or the "MA Board ASSY" needs to be replaced, check whether this information is readable. If yes, read it using the "IPS Tool (Resume)" program (dedicated program for services and support), and write it back onto the machine after completing repairs.
(See [3.5.9 The service tools and the adjustment tasks list which required before and after parts replacement \(p148\)](#))

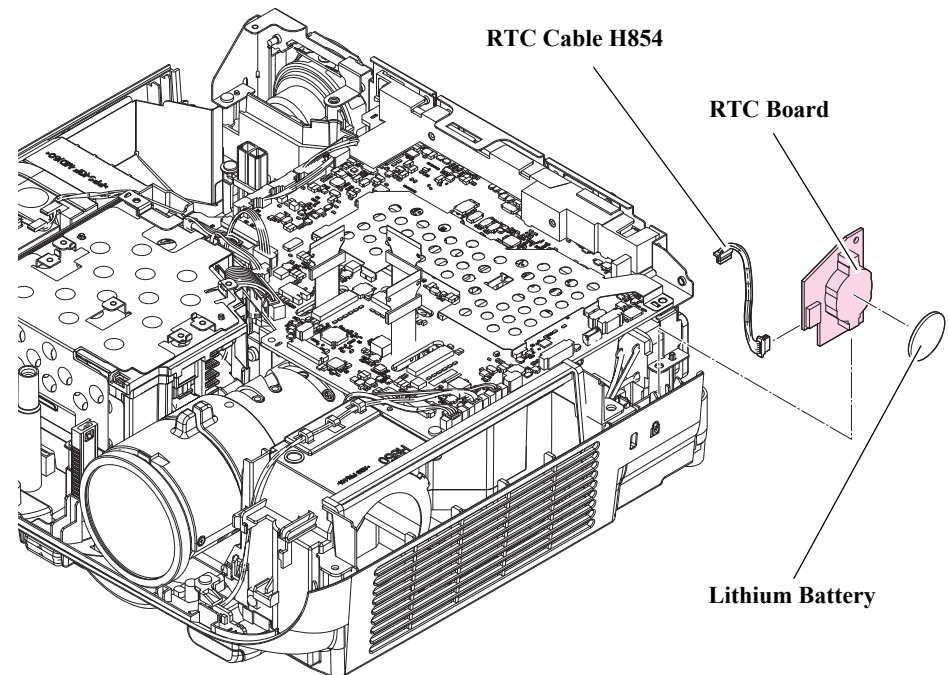



The time settings of the clock function are reset to their default values if the "RTC Board" or the Lithium Battery are replaced. Hence, you need to perform the following settings:

- **Time settings**
Set the time in the OSD menu. (The time should match the local time of the place where the projector is being used.)
- **Alert window for time setting at the time of initial startup by the user**
 1. Switch ON the power to start the projector.
 2. AS menu is displayed.
([4.1.1.1 How to enter the AS menu \(p171\)](#))
 3. While the AS menu is displayed, long press the [Source Search] button and [Right] button on the Control Panel simultaneously for five seconds or more.
 4. Restart the projector by switching off the power once and then switching it on again, and check that the following screen is displayed.

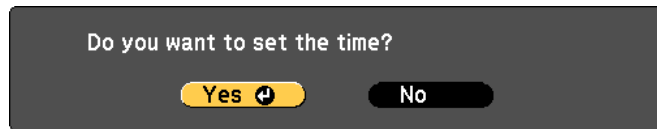

[Left Arrow]:Select [Right Arrow]:Execute

5. Switch off the power to the projector without selecting [Yes] or [No].

HOW TO REPLACE THE LITHIUM BATTERY



- There is a risk of explosion if the Lithium Battery is replaced with an incorrect type of battery. Ensure that a battery with the same model number is used.
 - When plugging or unplugging the Lithium Battery, make sure you fix the "RTC Board" such that the following conditions are satisfied.
 - There should be no arch even if the circuit board is pressed down at the time of replacement.
 - It must be fixed on an insulated stand, etc.
- Lithium Battery removal procedure
1. Place the circuit board in advance on an insulated stand that is not arched.
 2. Fix the circuit board with both hands in a flat position, and push the battery with your thumb in the direction of the arrow to release the Lithium Battery from the locking tab.
 3. The Lithium Battery is lifted up naturally by spring force. Remove the battery.

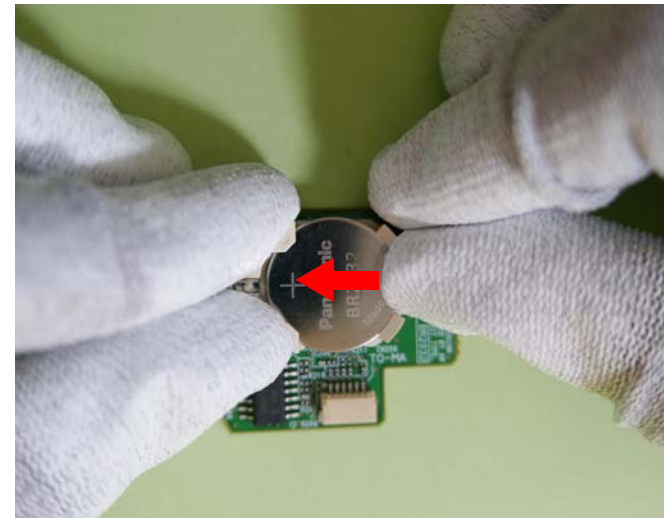



Used Lithium Battery should be treated or disposed of in the prescribed manner.

□ Lithium Battery fitting procedure

1. Place the circuit board in advance on an insulated stand that is not arched.



Ensure that the Lithium Battery is inserted by maintaining the correct angle as shown below.

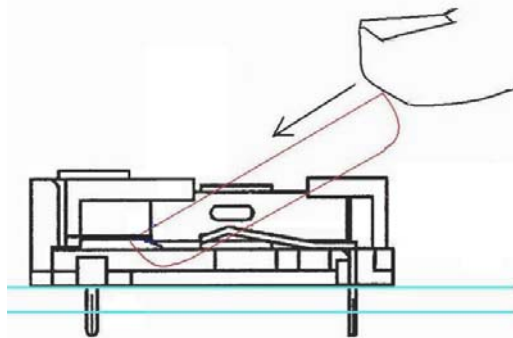

2. Fix the circuit board with both hands in a flat position, and insert the Lithium Battery in the direction of the arrow by maintaining the correct angle of insertion.

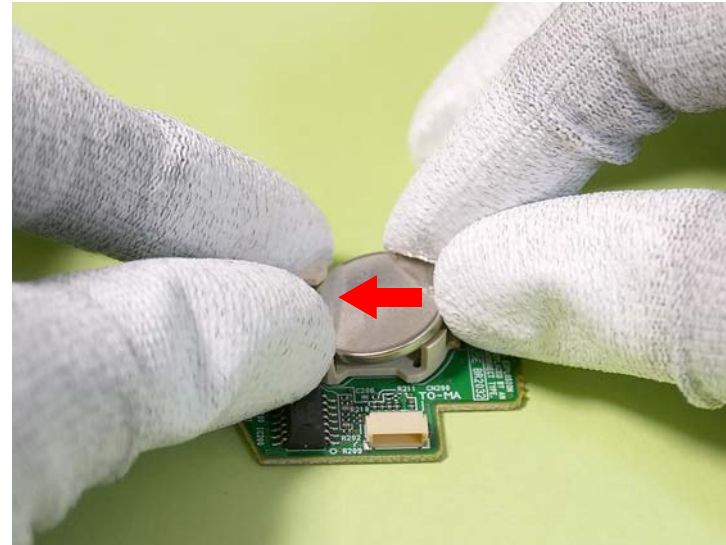

3. Check that the Lithium Battery is secured by the locking tabs as shown in the following photo.

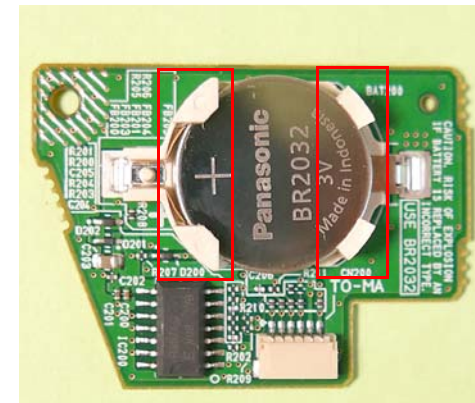

3.3.10 MA Board Assy

DISASSEMBLY PROCEDURE



- After connecting the connectors on the MA Board ASSY, check that there is no halfway or oblique insertion.
- For three connectors of the L/V FPC on the MA Board ASSY, connect the FPCs before attaching the MA Board ASSY, and make sure to lock to fix them.

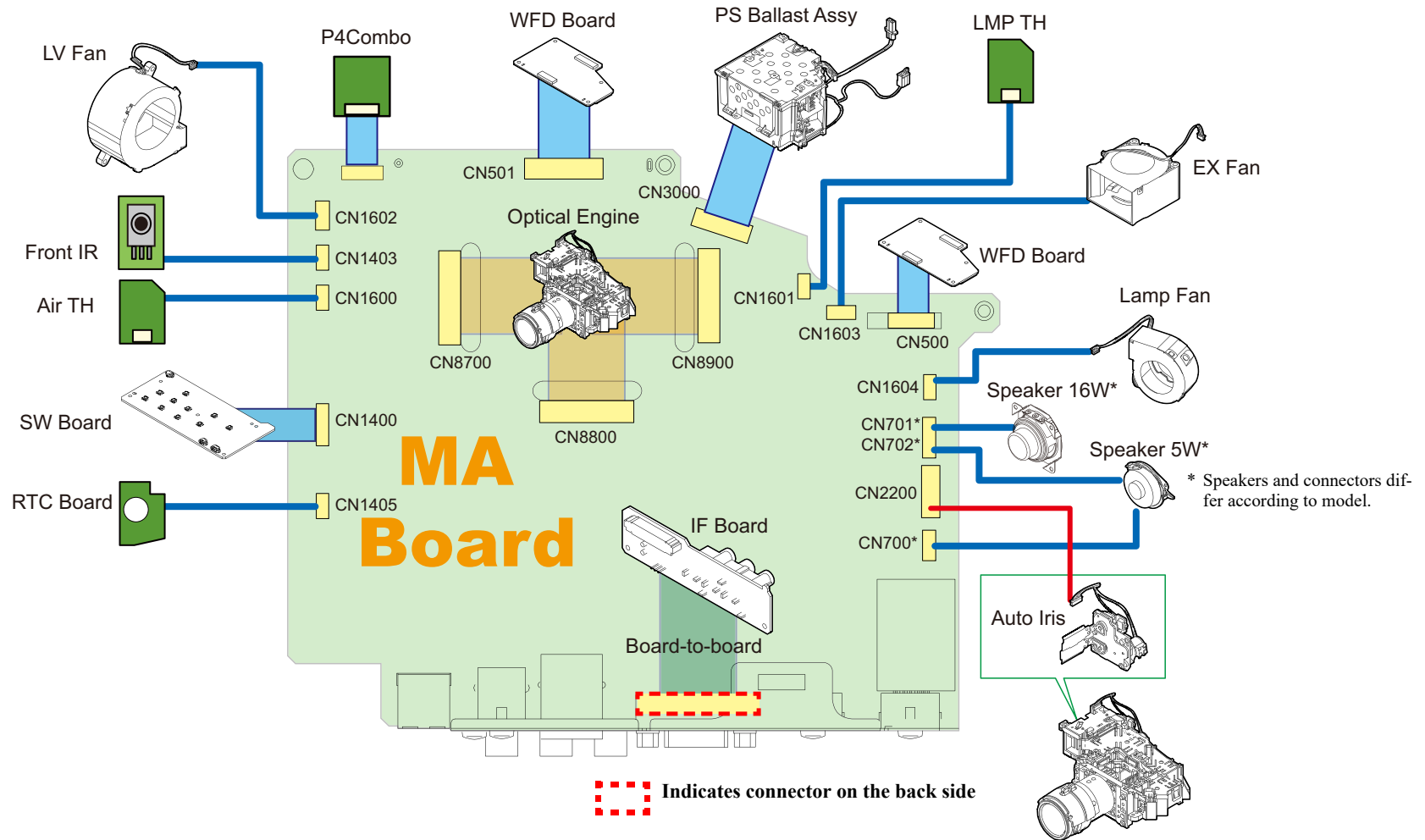

DISASSEMBLY PROCEDURE

□ EB-E01/X06/W06/E10/X51/W51/W52

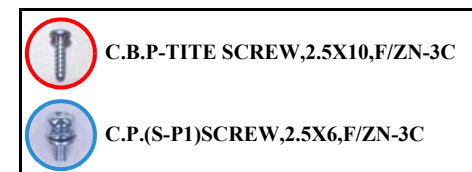
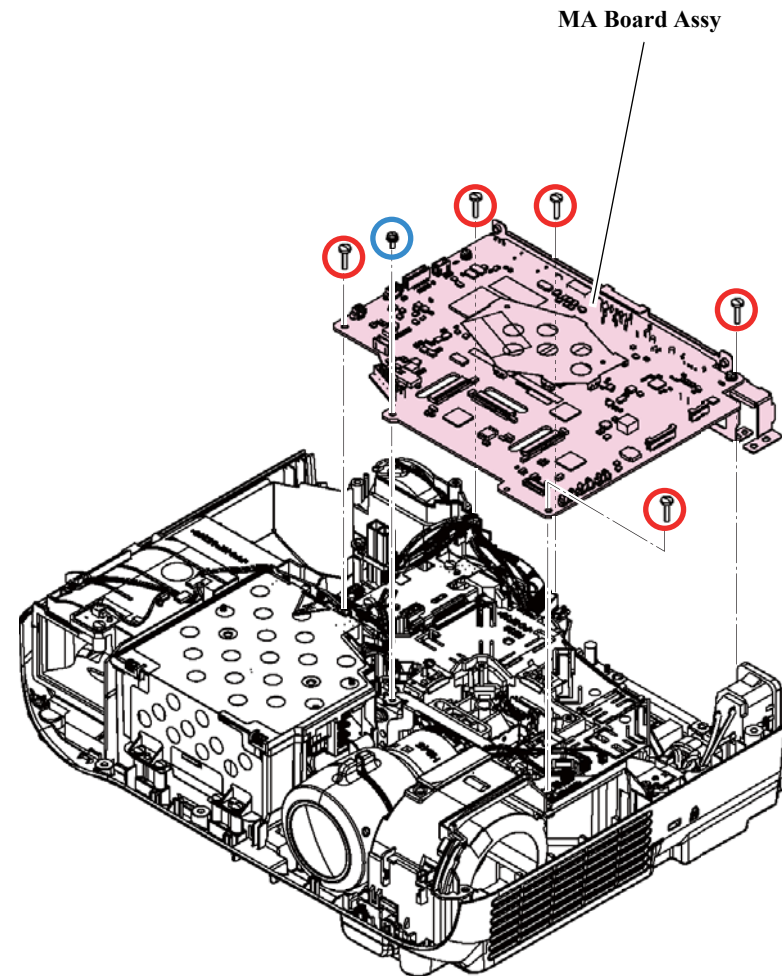
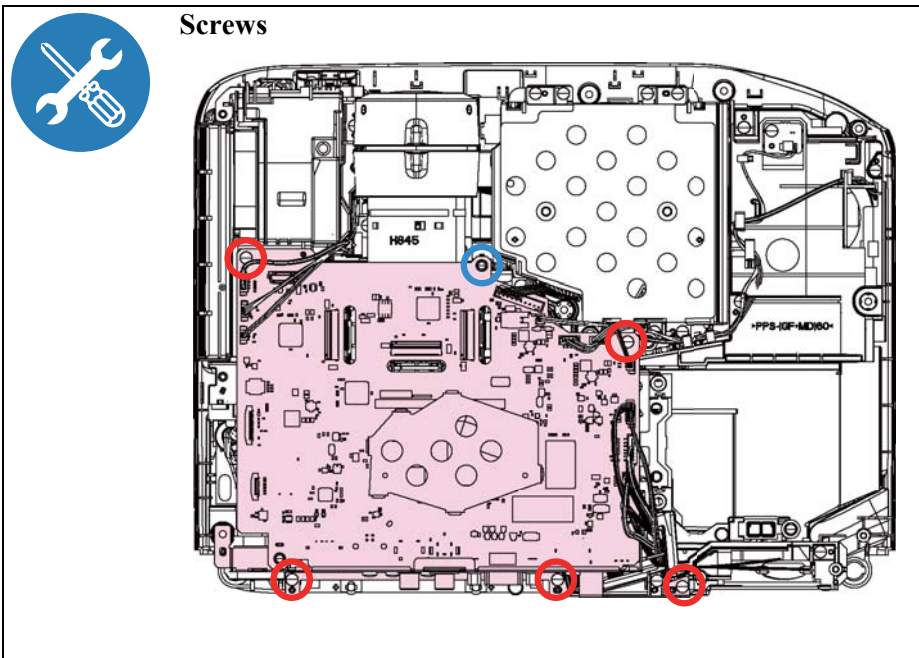

1. See *Flowchart (p70)* and remove all parts up to the component below from the projector.
Upper Case (Assy) (p80)
2. Disconnect the connectors from the "MA Board Assy".
3. Remove the six screws (○/○) and remove the "MA Board Assy".

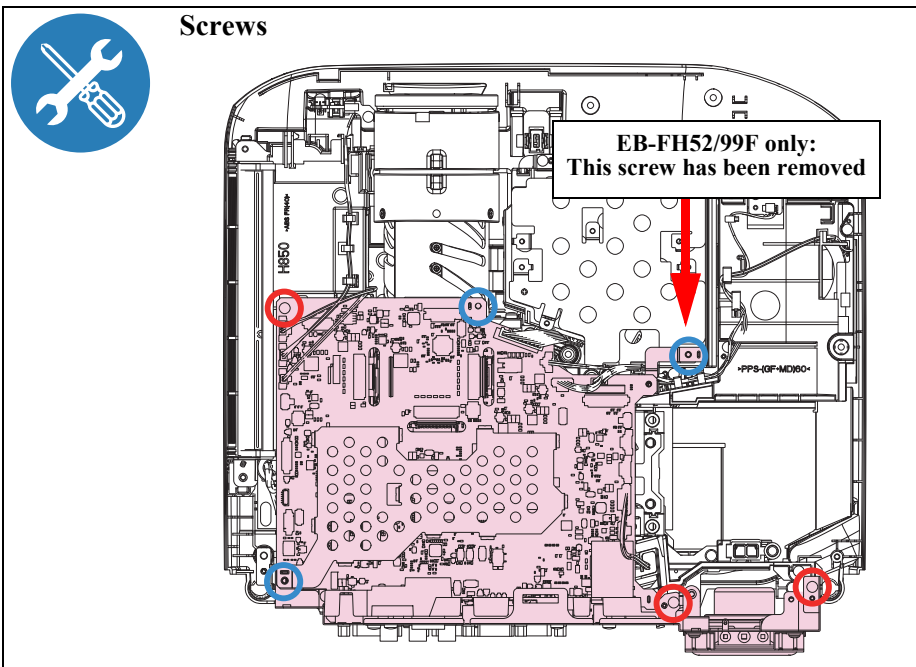
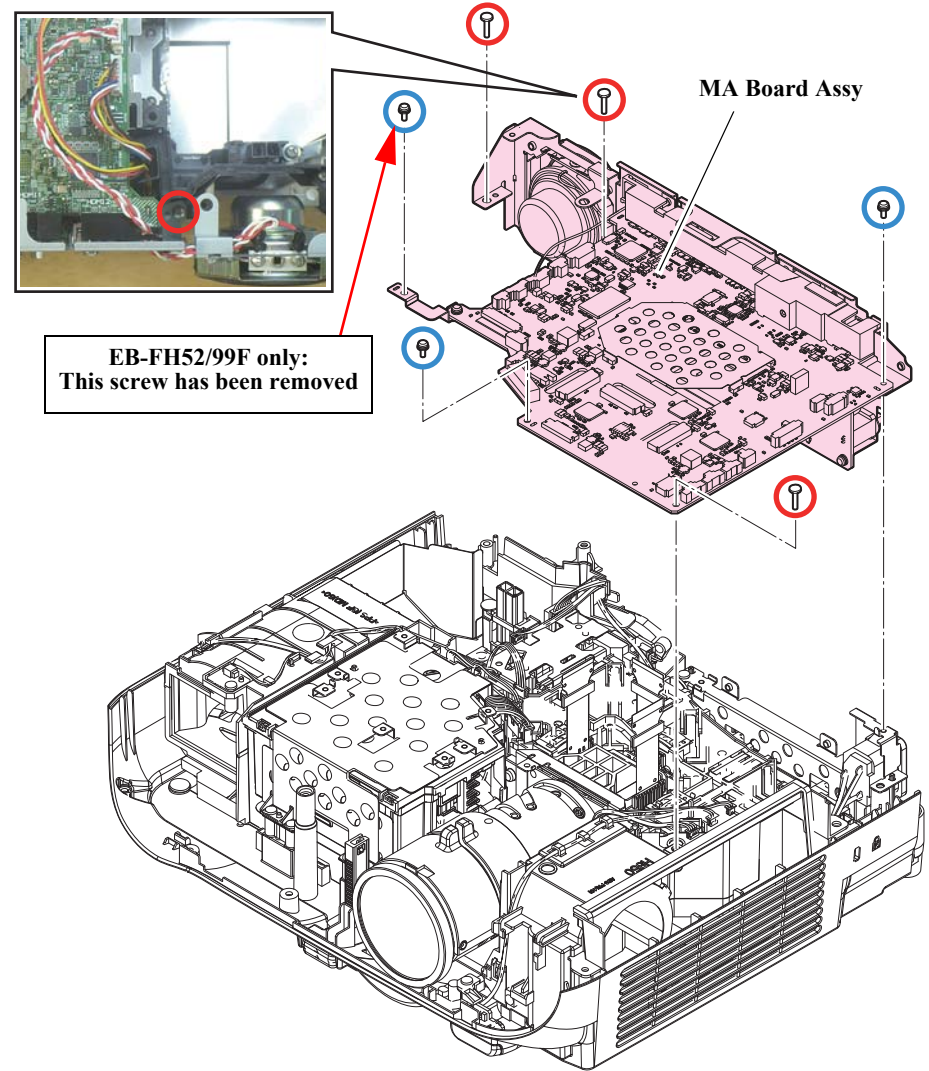

□ EB-FH52/972/982W/992F/118, PL 119W

1. See *Flowchart (p70)* and remove all parts up to the component below from the projector.
 * EB-972/982W/118, PL 119W
Upper Case (Assy) (p80)
 * EB-FH52/992F
WFD Board (p94)
2. Disconnect the connectors from the "MA Board Assy".
3. Remove the five (six) screws (○/○), and remove the "MA Board Assy".



	C.B.P-TITE SCREW,2.5X10,F/ZN-3C
	C.P.(S-P1)SCREW,2.5X6,F/ZN-3C

□ EB-E20/X49/W49/FH06, EH-TW740/TW750

1. See *Flowchart (p70)* and remove all parts up to the component below from the projector.
 - * EB-E20/X49/W49/FH06, EH-TW740
Upper Case (Assy) (p80)
 - * EH-TW750
WFD Board (p94)
2. Disconnect the connectors from the "MA Board Assy".
3. Remove the five (six) screws (○/○), and remove the "GND Cable" and the "MA Board Assy".

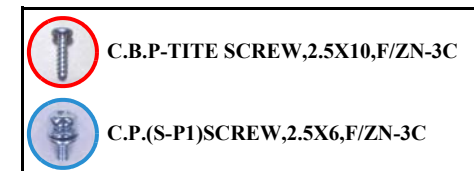
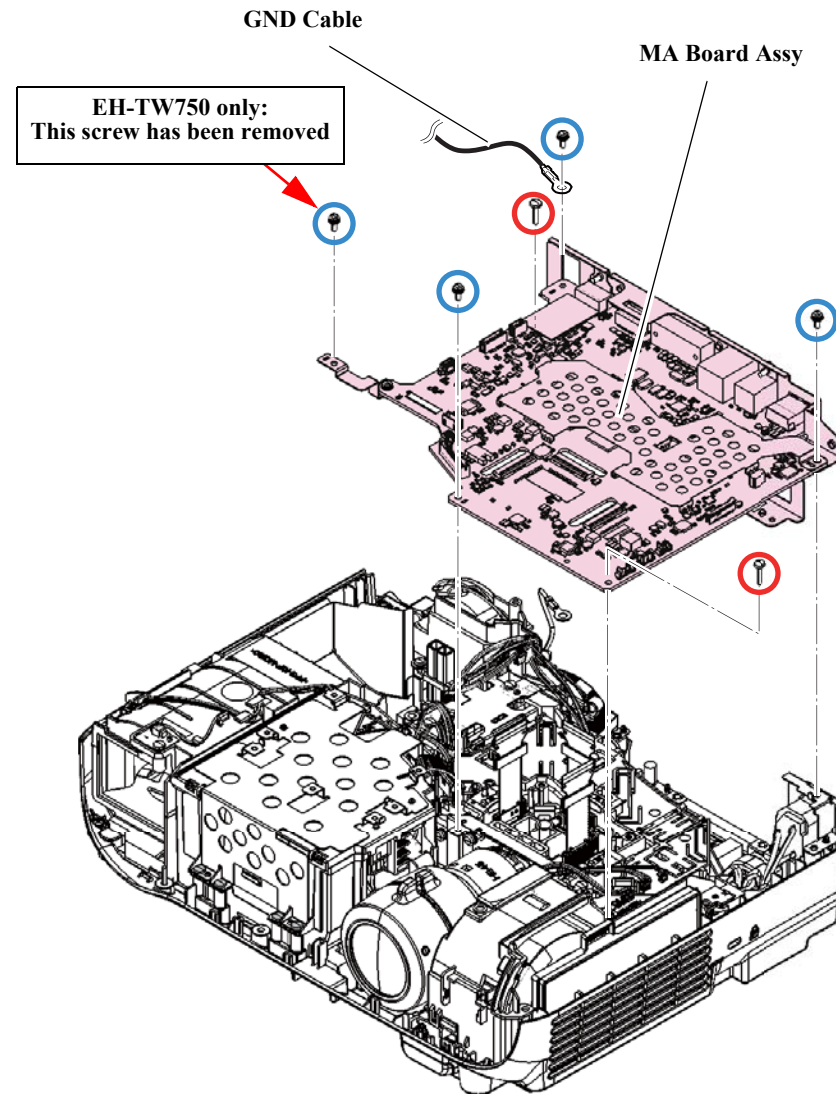
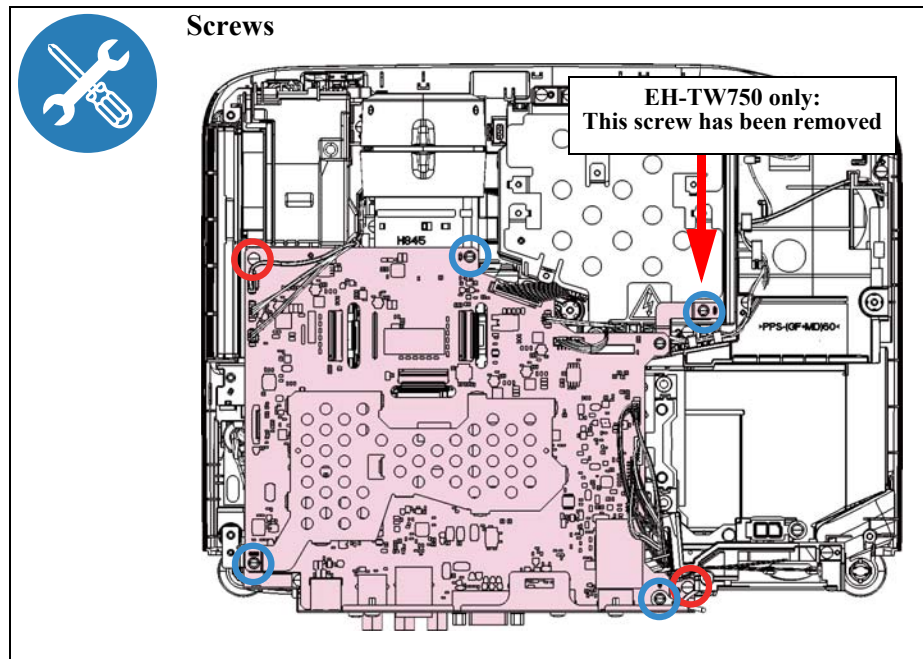



Connect the MA Board ASSY connectors as shown in this figure.

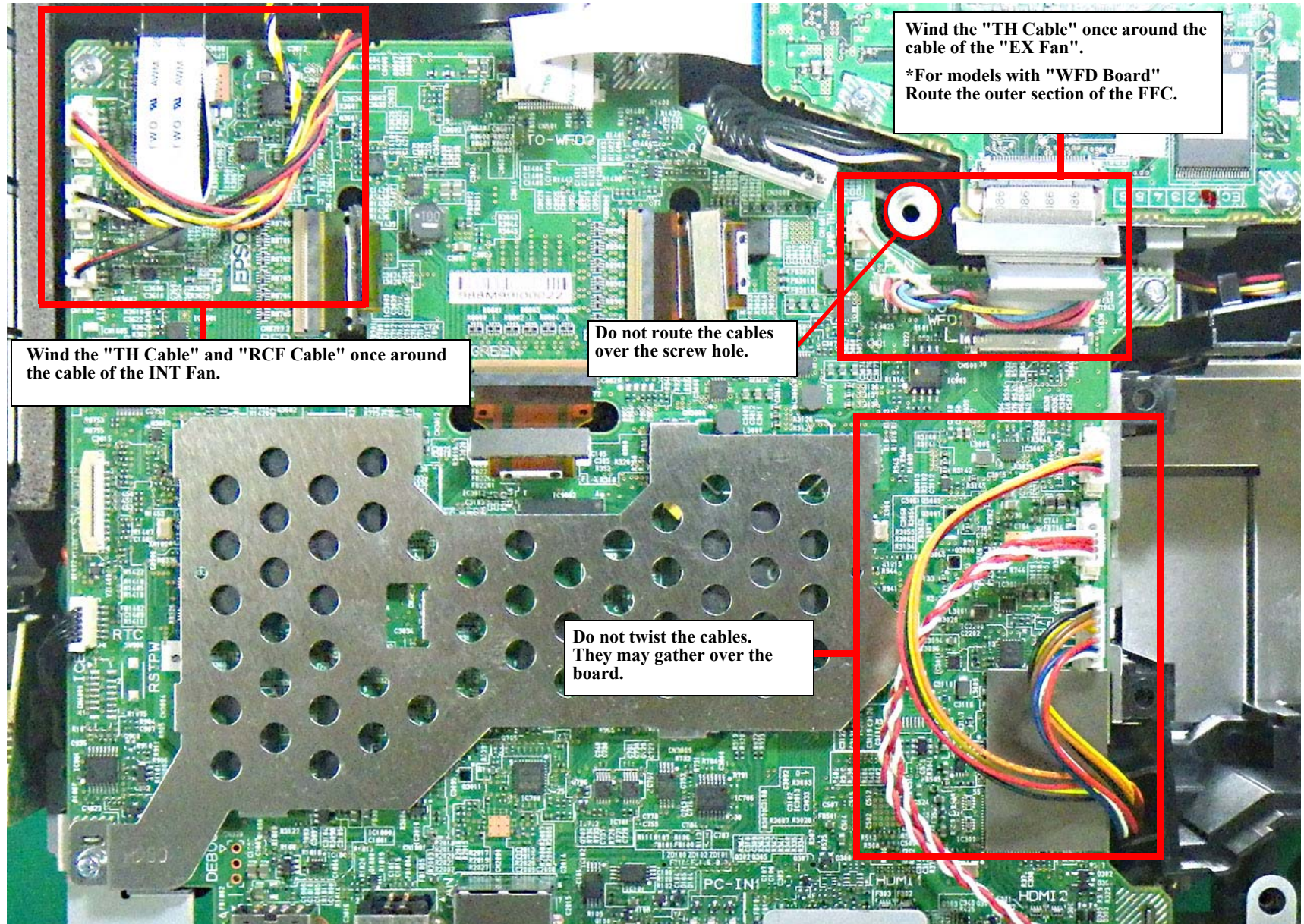

Wind the "TH Cable" and "RCF Cable" once around the cable of the INT Fan.

Do not route the cables over the screw hole.

Wind the "TH Cable" once around the cable of the "EX Fan".
*For models with "WFD Board" Route the outer section of the FFC.

Do not twist the cables. They may gather over the board.

3.3.10.1 Speaker 16W

DISASSEMBLY PROCEDURE

- EB-FH52/972/982W/992F/118, PL 119W
- 1. See [Flowchart \(p70\)](#) and remove all parts up to the component below from the projector.
[MA Board Assy \(p100\)](#)
- 2. Remove the four screws (○) and remove the "Speaker 16W".

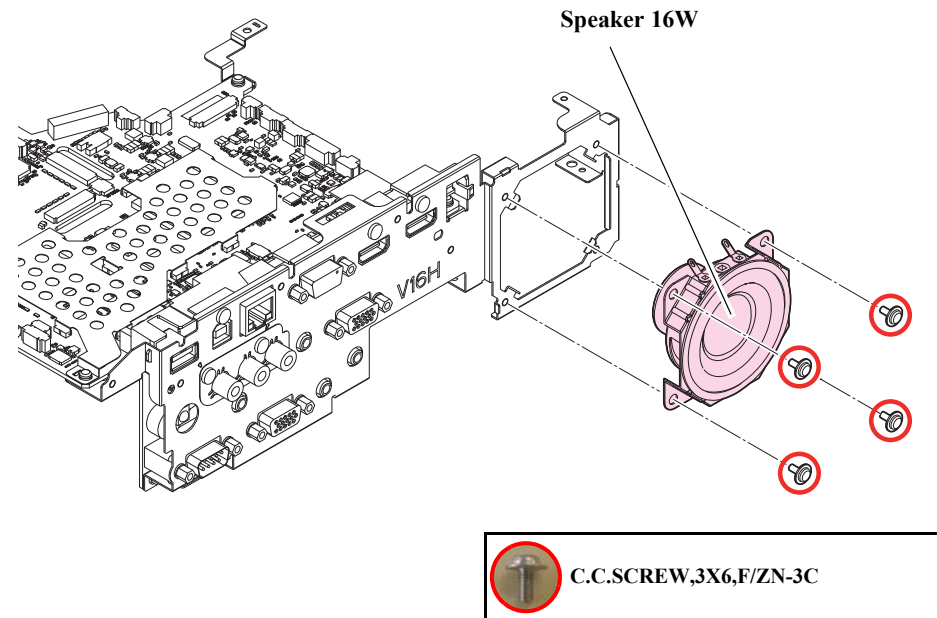





3.3.10.2 IF Board

DISASSEMBLY PROCEDURE

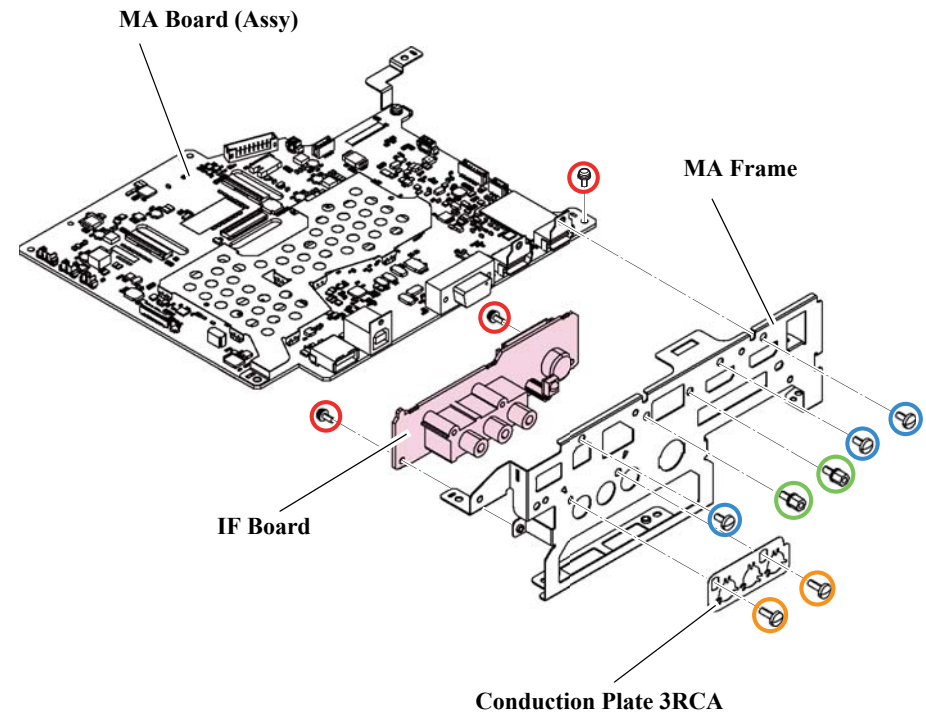
□ EB-FH06

1. See *Flowchart (p70)* and remove all parts up to the component below from the projector.
MA Board Assy (p100)
2. Remove the two screws (○) and remove the "Conduction Plate 3RCA" from the "MA Frame".
3. Remove the one screw (○), the three screws (○), the two screws (○), and remove the "MA Frame" from the "MA Board (Assy)".
4. Remove the two screws (○) and remove the "IF Board" from the "MA Board (Assy)".





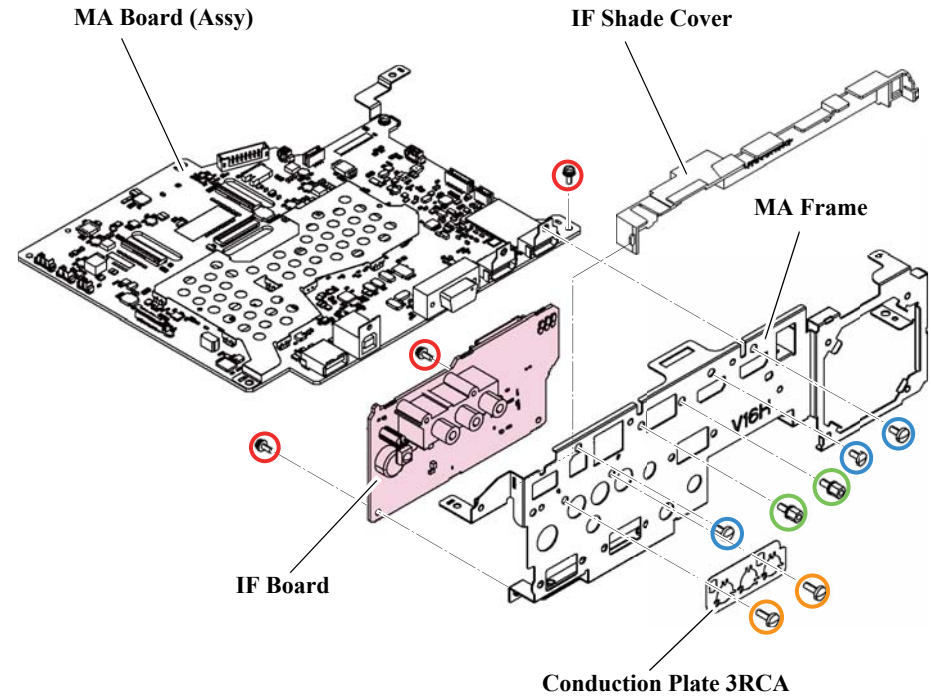

	C.P.(S-P1)SCREW,2.5X6,F/ZN-3C		1/4-40X1/4,H.H.,F/NI,O SCREW
	C.B.SCREW,3X6,F/NI		C.B.P-TITE SCREW,3X8,F/ZN-3C

□ EB-FH52

1. See *Flowchart (p70)* and remove all parts up to the component below from the projector.
MA Board Assy (p100)
2. Remove the "IF Shade Cover".
3. Remove the two screws (○) and remove the "Conduction Plate 3RCA" from the "MA Frame".
4. Remove the one screw (○), the three screws (○), the two screws (○), and remove the "MA Frame" from the "MA Board (Assy)".
5. Remove the two screws (○) and remove the "IF Board" from the "MA Board (Assy)".



	C.P.(S-P1)SCREW,2.5X6,F/ZN-3C		1/4-40X1/4,H.H.,F/NI,O SCREW
	C.B.SCREW,3X6,F/NI		C.B.P-TITE SCREW,3X8,F/ZN-3C

□ EH-TW740



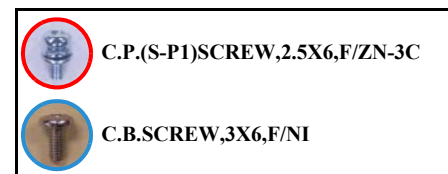
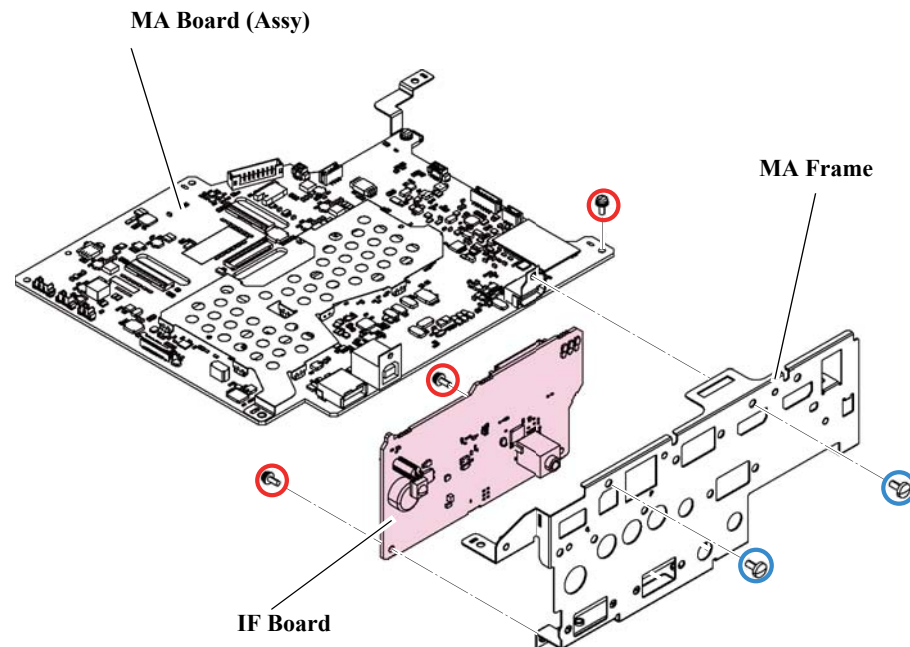

1. See *Flowchart (p70)* and remove all parts up to the component below from the projector.
MA Board Assy (p100)
2. Remove the one screw (○), the three screws (○), and remove the "MA Frame" from the "MA Board (Assy)".
3. Remove the two screws (○) and remove the "IF Board" from the "MA Board (Assy)".

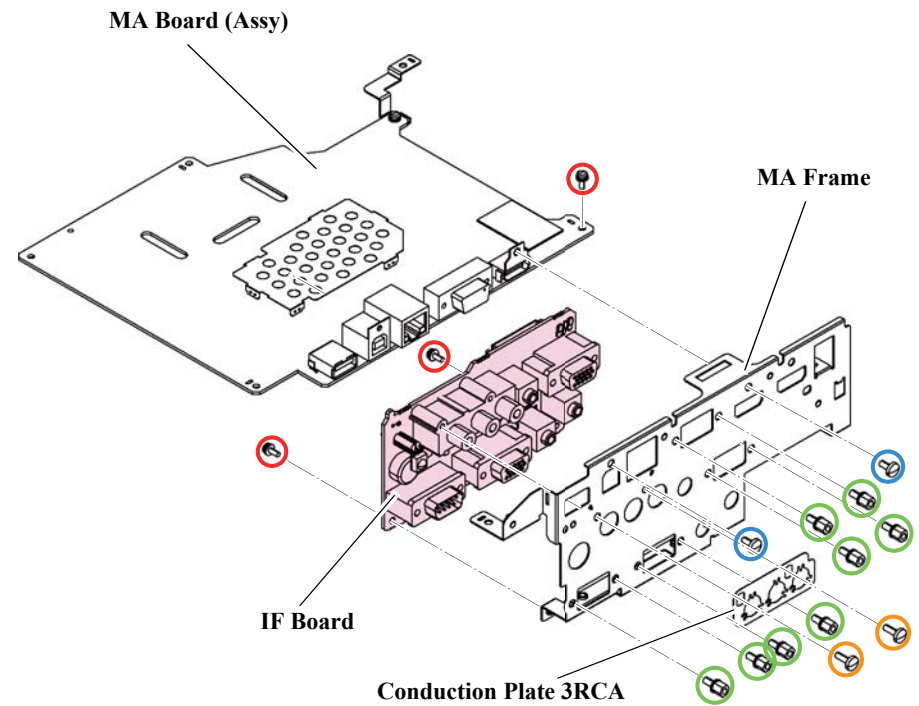

□ EB-E20/X49

1. See *Flowchart (p70)* and remove all parts up to the component below from the projector.
MA Board Assy (p100)
2. Remove the two screws (○) and remove the "Conduction Plate 3RCA" from the "MA Frame".
3. Remove the one screw (○), the two screws (○), the eight screws (○), and remove the "MA Frame" from the "MA Board (Assy)".
4. Remove the two screws (○) and remove the "IF Board" from the "MA Board (Assy)".





	C.P.(S-P1)SCREW,2.5X6,F/ZN-3C		1/4-40X1/4,H.H.,F/NI,O SCREW
	C.B.SCREW,3X6,F/NI		C.B.P-TITE SCREW,3X8,F/ZN-3C

□ EB-W49

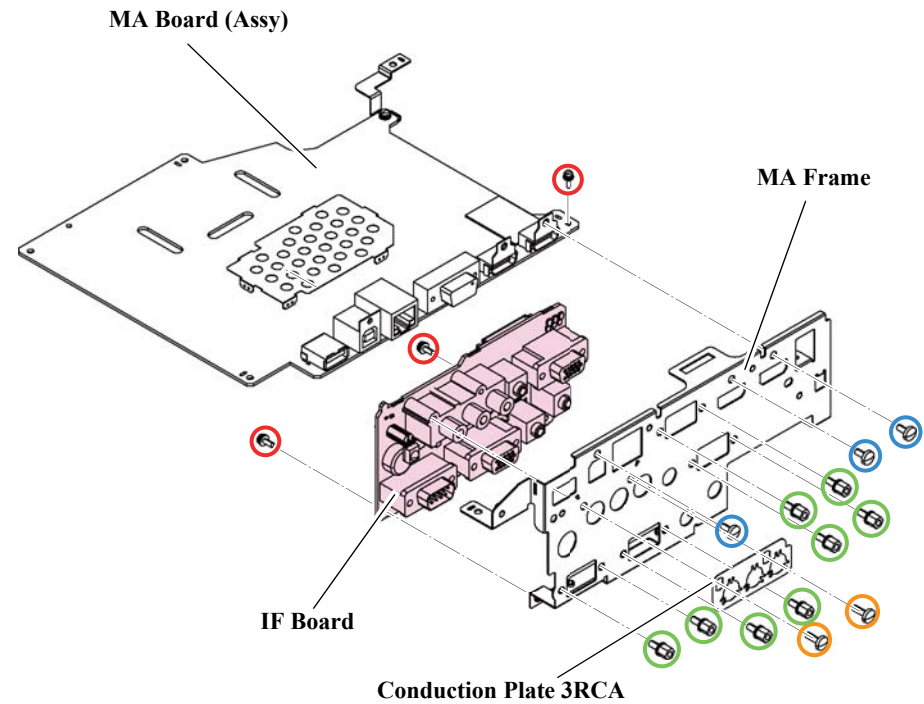
1. See *Flowchart (p70)* and remove all parts up to the component below from the projector.
MA Board Assy (p100)
2. Remove the two screws (○) and remove the "Conduction Plate 3RCA" from the "MA Frame".
3. Remove the one screw (○), the three screws (○), the eight screws (○), and remove the "MA Frame" from the "MA Board (Assy)".
4. Remove the two screws (○) and remove the "IF Board" from the "MA Board (Assy)".





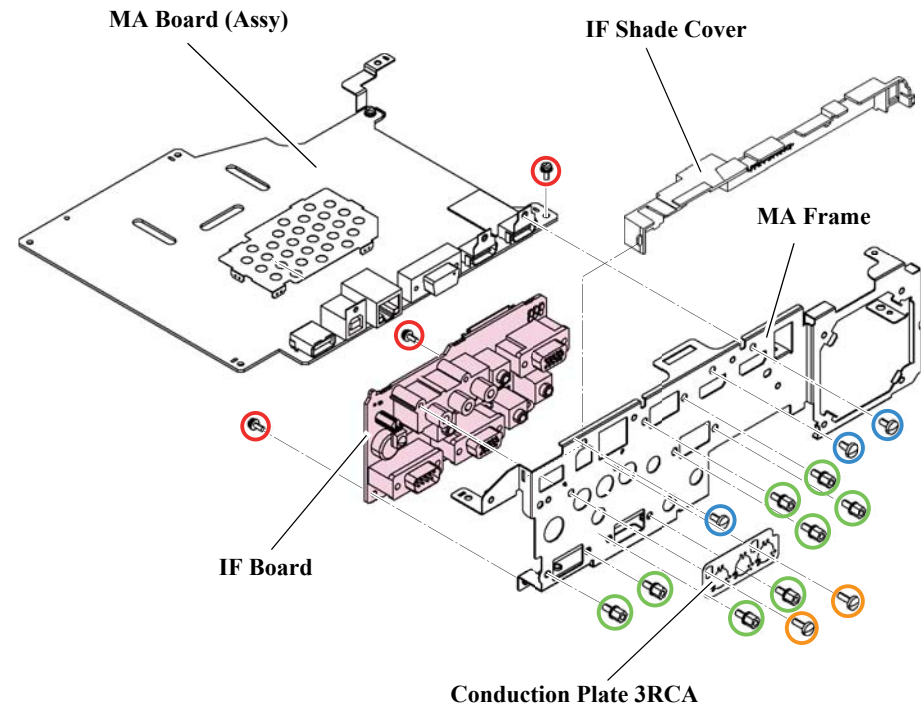

	C.P.(S-P1)SCREW,2.5X6,F/ZN-3C		1/4-40X1/4,H.H.,F/NI,O SCREW
	C.B.SCREW,3X6,F/NI		C.B.P-TITE SCREW,3X8,F/ZN-3C

□ EB-972/982W/992F/118, PL 119W

1. See *Flowchart (p70)* and remove all parts up to the component below from the projector.
MA Board Assy (p100)
2. Remove the "IF Shade Cover".
3. Remove the two screws (○) and remove the "Conduction Plate 3RCA" from the "MA Frame".
4. Remove the one screw (○), the three screws (○), the eight screws (○), and remove the "MA Frame" from the "MA Board (Assy)".
5. Remove the two screws (○) and remove the "IF Board" from the "MA Board (Assy)".





	C.P.(S-P1)SCREW,2.5X6,F/ZN-3C		1/4-40X1/4,H.H.,F/NI,O SCREW
	C.B.SCREW,3X6,F/NI		C.B.P-TITE SCREW,3X8,F/ZN-3C

□ EH-TW750

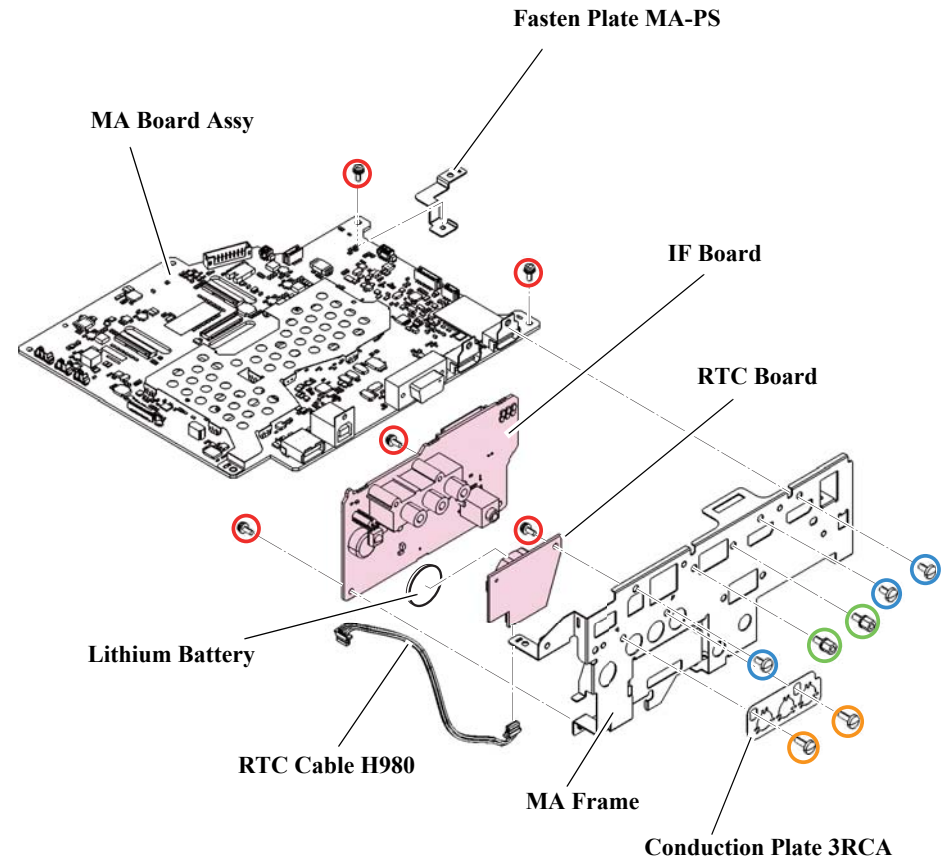
1. See [Flowchart \(p70\)](#) and remove all parts up to the component below from the projector.
[MA Board Assy \(p100\)](#)
2. Disconnect the connectors of the "RTC Cable H980" from the "MA Board (Assy)".
3. Remove the two screws (○) and remove the "Conduction Plate 3RCA" from the "MA Frame".
4. Remove the two screws (○), the three screws (○), the two screws (○), and remove the "MA Frame" and the "Fasten Plate MA-PS" from the "MA Board (Assy)".
5. Remove the two screws (○) and remove the "IF Board" from the "MA Board (Assy)".
6. Remove the one screw (○) and remove the "RTC Board" from the "MA Frame".
7. Remove the "RTC Cable H980" and the "Lithium Battery" from the "RTC Board".



When replacing the "RTC Board" or "Lithium Battery" for repairs, refer to [RTC Board \(p.97\)](#) for configuration or replacement.

	C.P.(S-P1)SCREW,2.5X6,F/ZN-3C		1/4-40X1/4,H.H.,F/NI,O SCREW
	C.B.SCREW,3X6,F/NI		C.B.P-TITE SCREW,3X8,F/ZN-3C

3.3.11 Optical Engine (Assy)

DISASSEMBLY PROCEDURE

1. See [Flowchart \(p70\)](#) and remove all parts up to the component below from the projector.
[MA Board Assy \(p100\)](#)
2. Remove the four screws (○) and remove the "Optical Engine Assy".

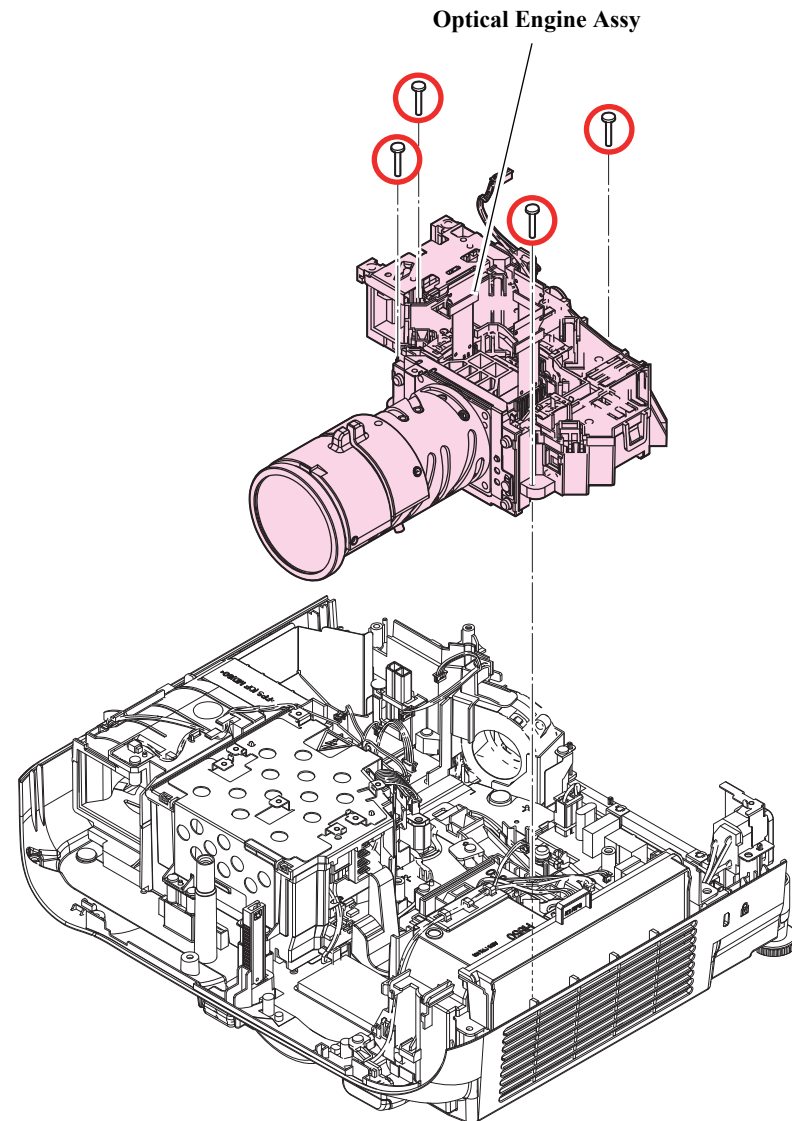
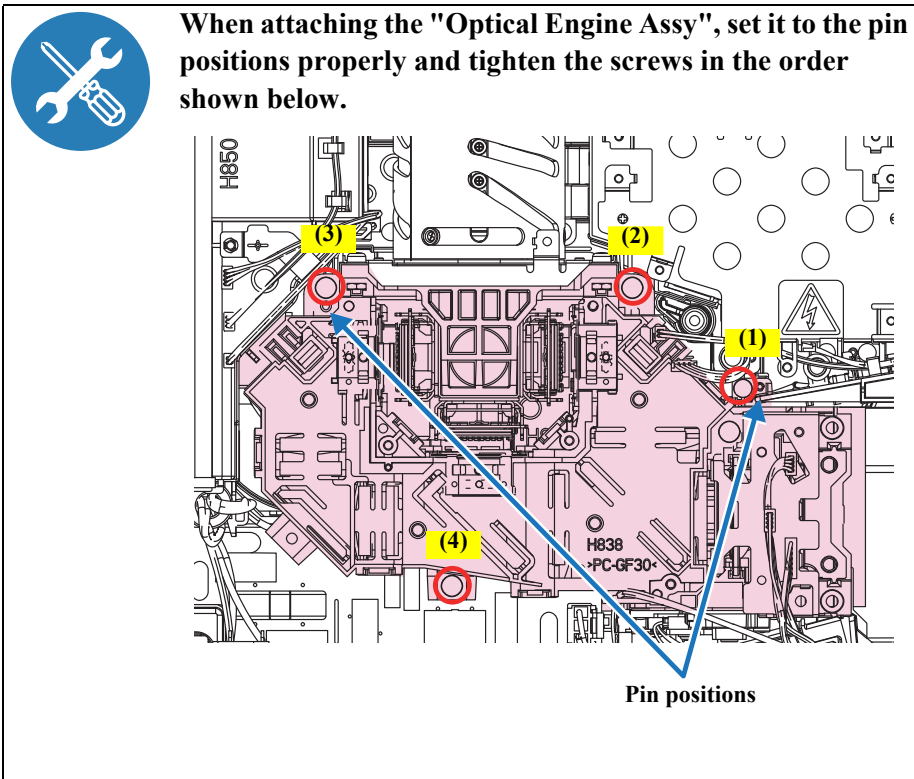



Pass the "Auto Iris Assy" cable through the two hooks.

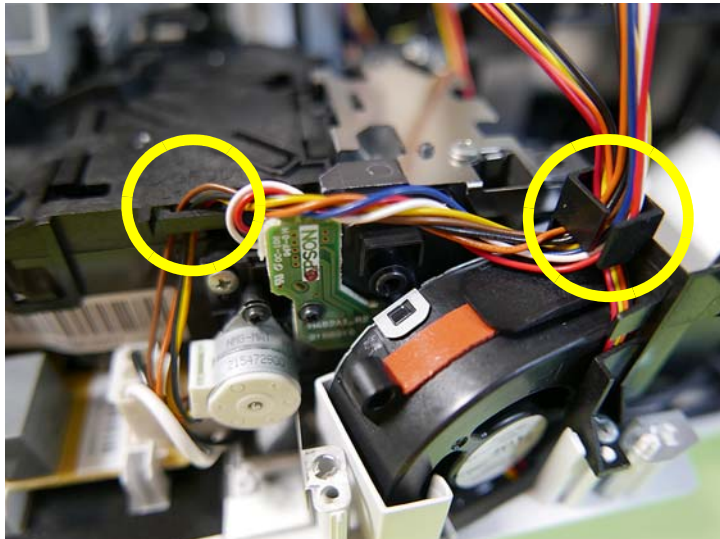

When handling the optical engine, do not apply force on the Upper Light Guide.

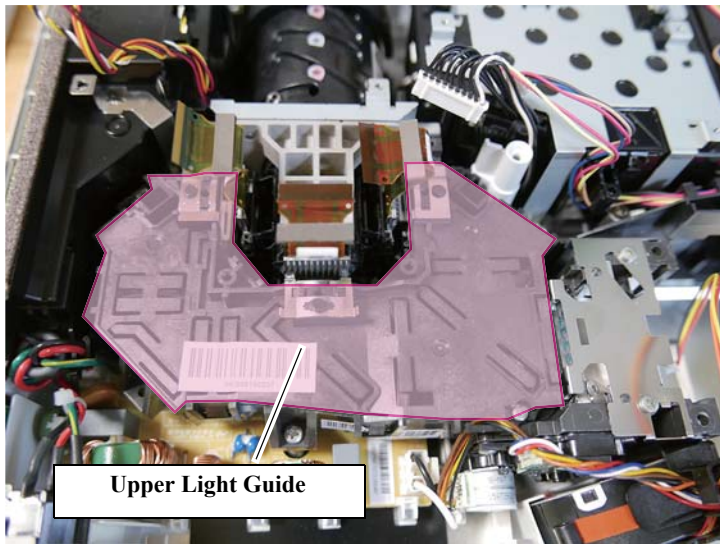

3.3.11.1 Auto Iris Assy

DISASSEMBLY PROCEDURE

1. See *Flowchart (p70)* and remove all parts up to the component below from the projector.
Optical Engine (Assy) (p113)
2. Remove the two screws (○) and remove the "Auto Iris Assy".



Before attaching or removing the "Auto Iris Assy", move the Auto Iris Blades to the home position by inserting a Phillips screw driver (No0) into the holes shown in the figure below.

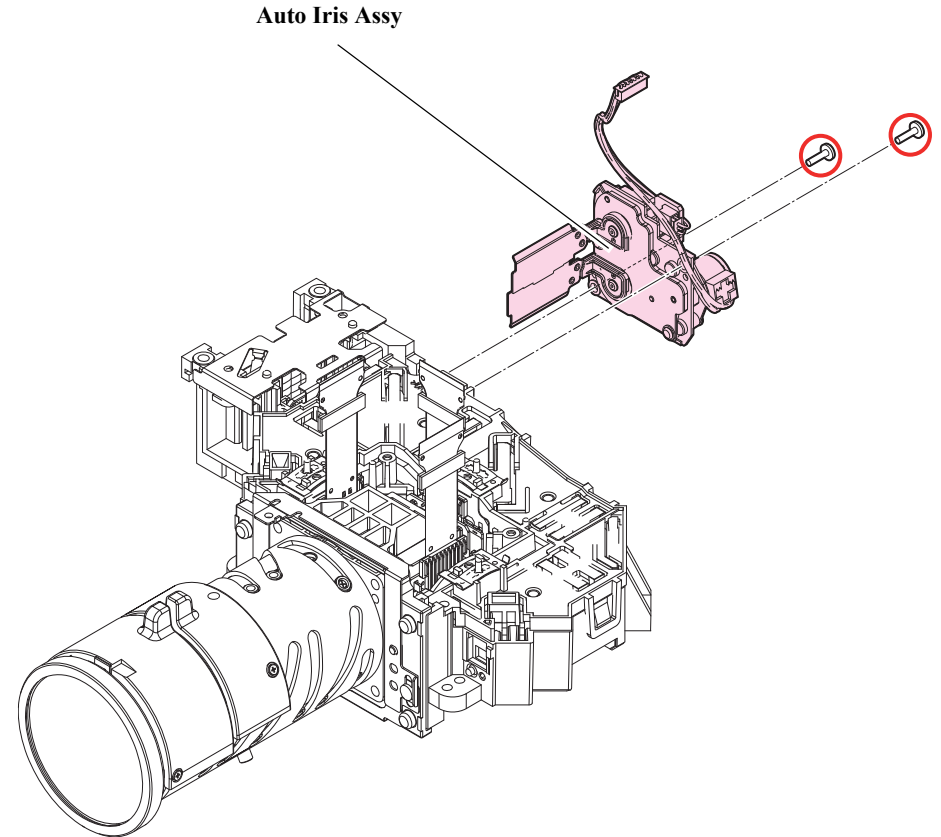
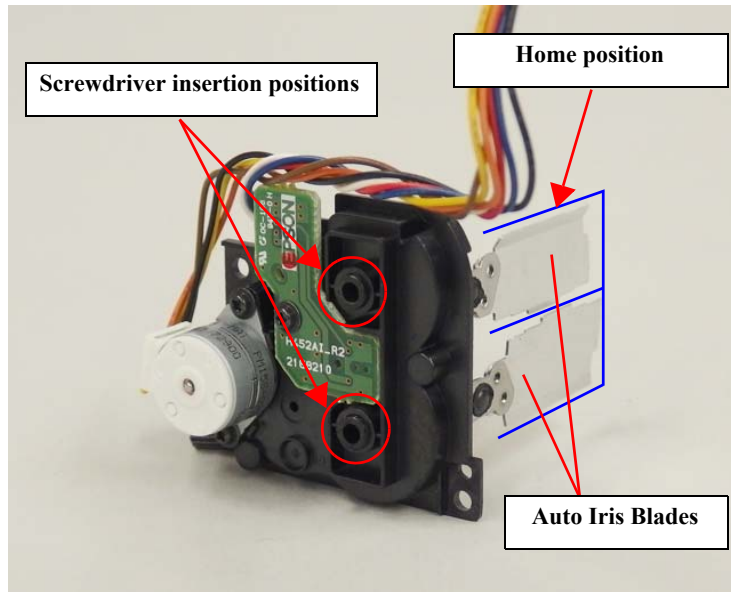

3.3.11.2 Focus Ring/Zoom Ring

DISASSEMBLY PROCEDURE

1. See *Flowchart (p70)* and remove all parts up to the component below from the projector.
Optical Engine (Assy) (p113)
2. Remove three to five screws (⊙) and remove the "Focus Ring" and the "Zoom Ring".
* Numbers of screws and types of rings to be removed depend on the model. See the figures.

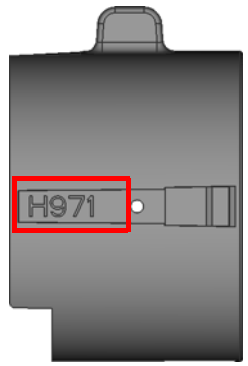
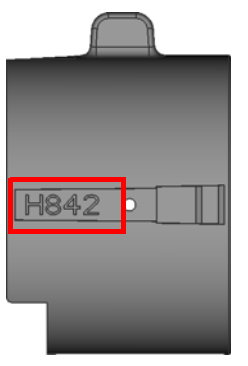

The shape of the FOCUS RING of EH-TW740 differs for EB-E01/E10/E20. Check the engraved seal before attaching.

EH-TW740	EB-E01/E10/E20
	

■ EB-E01/E10/E20, EH-TW740

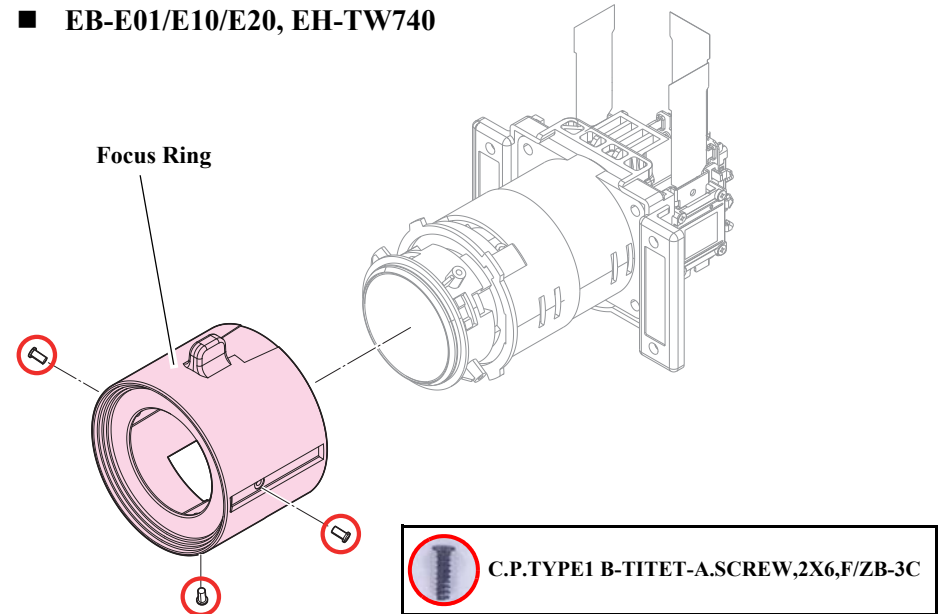

■ EB-X06/W06/FH06/X51/W51/X49/W49/W52/118, PL 119W

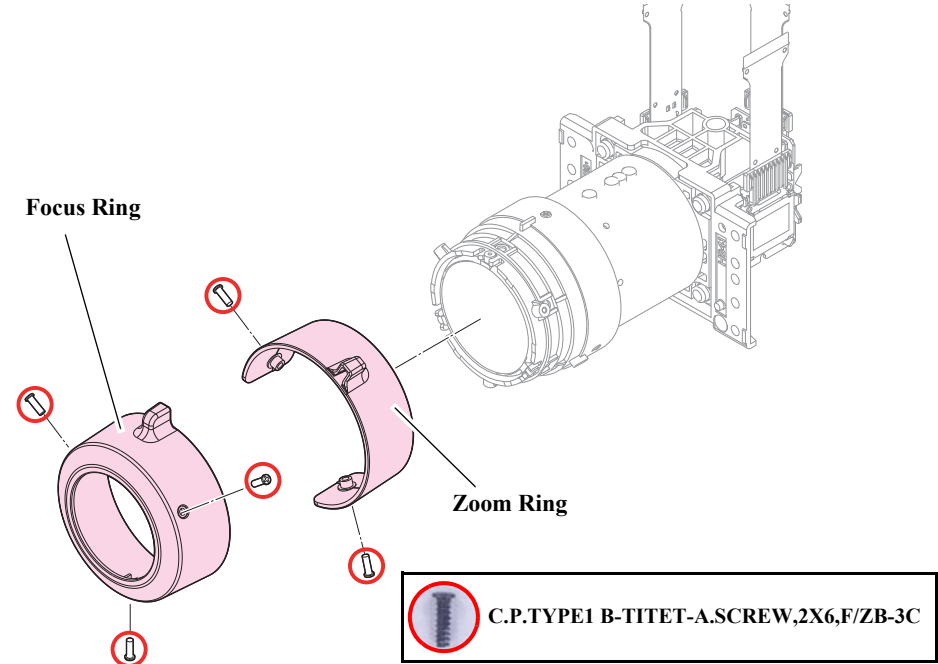

■ EH-TW750

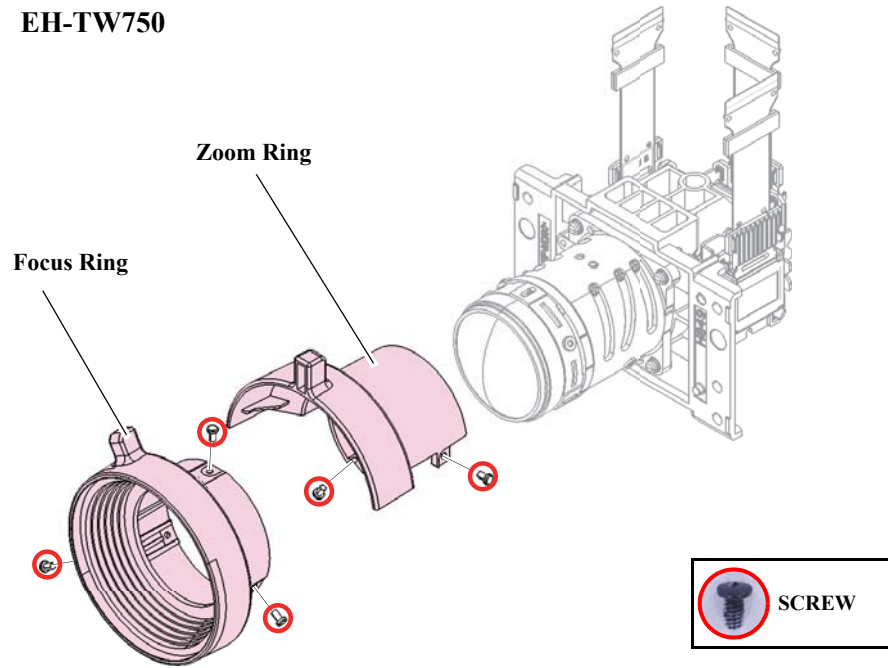

■ EB-FH52/972/982W/992F

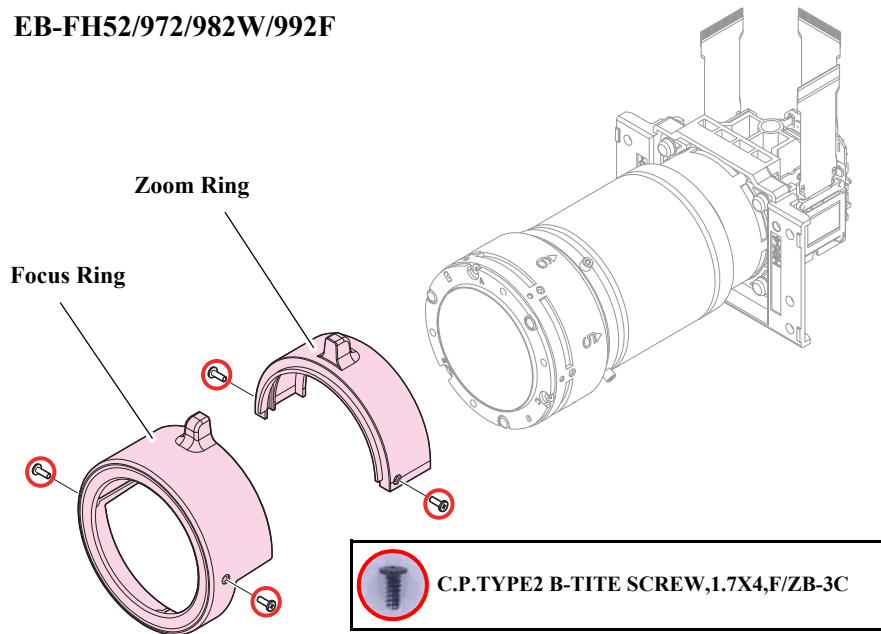

3.3.12 EX Duct (Assy)



At the area shown below, an electric shock may result if you operate carelessly because there is electric charge remaining in the Power Supply. [3.3.14 PS Ballast Assy \(p122\)](#)

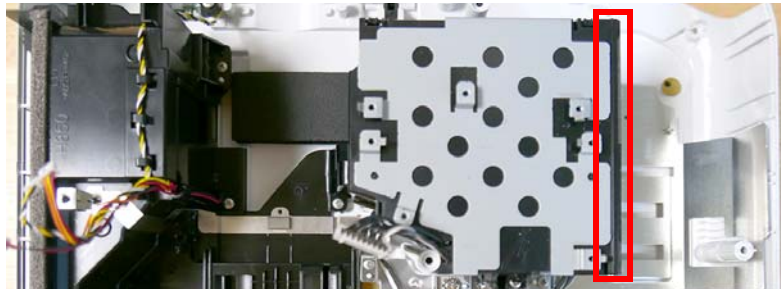

DISASSEMBLY PROCEDURE

1. See [Flowchart \(p70\)](#) and remove all parts up to the component below from the projector.
[Optical Engine \(Assy\) \(p113\)](#)
2. Remove the two screws (○) and the screw (●), remove the Thermostat of the "Cable PS-FB" and then remove the "EX Duct (Assy)".



Pass the cable through the "EX Duct (Assy)" and set the thermostat of the "Cable PS-FB" such that the surface with the letters is visible from top to bottom.

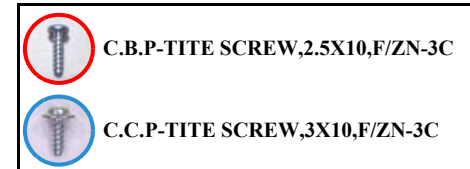
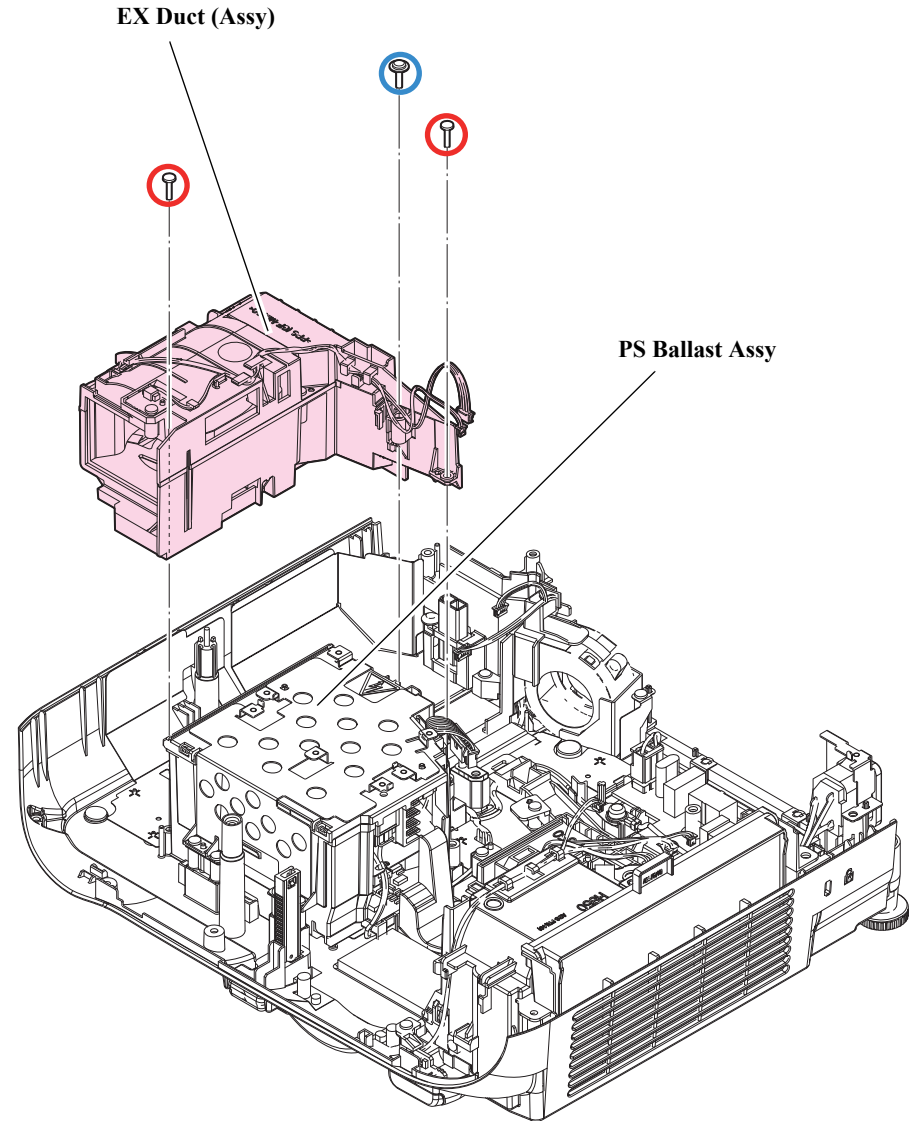
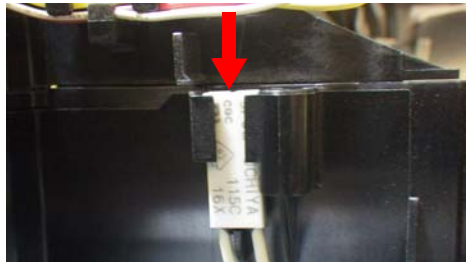

3.3.12.1 EX Fan/TH Board

DISASSEMBLY PROCEDURE

1. See [Flowchart \(p70\)](#) and remove all parts up to the component below from the projector.
[EX Duct \(Assy\) \(p118\)](#)
2. Remove the screw (○) and remove the "TH Board" and the "TH Cable H838".
3. Remove the two screws (○) and remove the "Upper EX Duct".
4. Remove the following parts from the "Lower EX Duct".
 - EX Plate
 - EX Fan
 - EX Fan Cushion A x2 pcs
 - EX Fan Cushion B

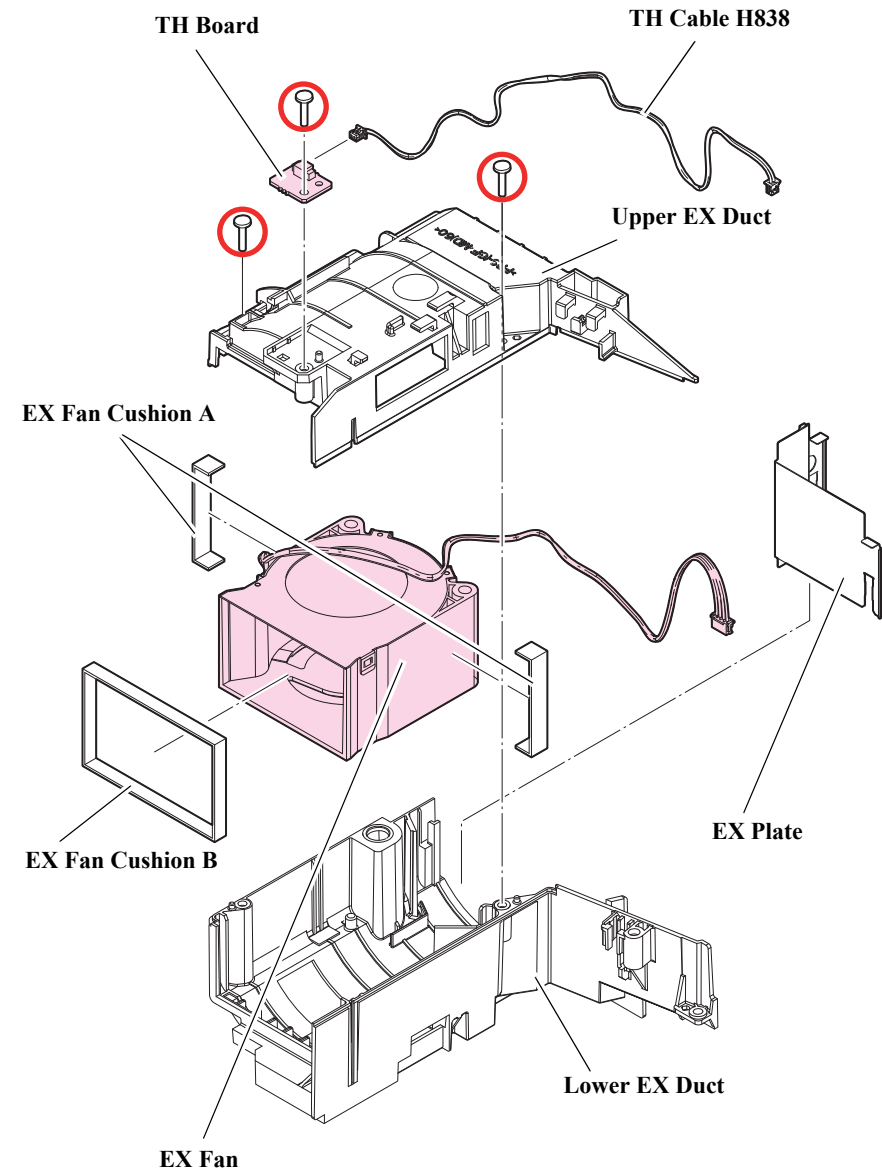

Route the cable on the EX Duct as shown in the figure below.
The cables should not be stranded by the hooks.

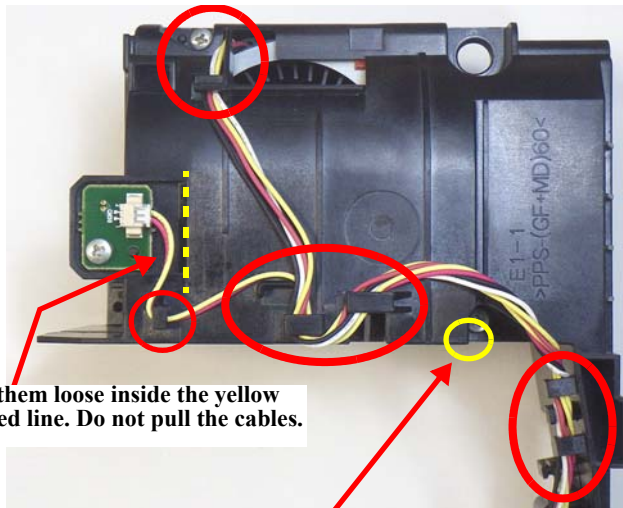

Let them loose inside the yellow dotted line. Do not pull the cables.

Twist the cables thrice clockwise and route them so that they do not affect this part.



3.3.13 Lamp Fan (Assy)

DISASSEMBLY PROCEDURE

1. See *Flowchart (p70)* and remove all parts up to the component below from the projector.
Optical Engine (Assy) (p113)
2. Remove the screw (○), and pull the "Lamp Connector" out.
3. Remove the two screws (○), and remove the "Lamp Fan (Assy)".



Pass the Lamp Connector through the "Lamp Connector Holder," and keep it pulled out until attaching. After attaching the holder, fix it with a screw.



Route the "Lamp Fan" cable as shown in the figure below.

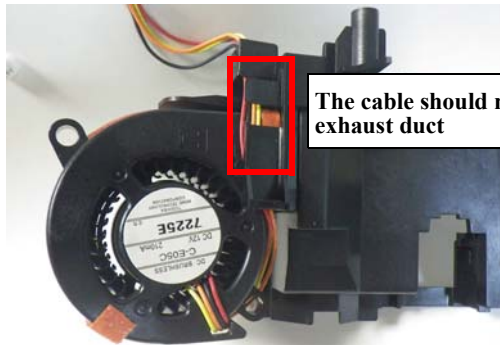

The cable should not be caught in the exhaust duct

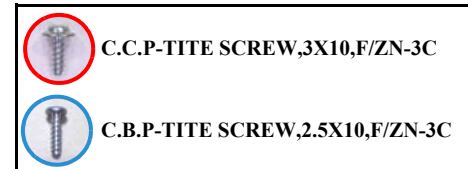
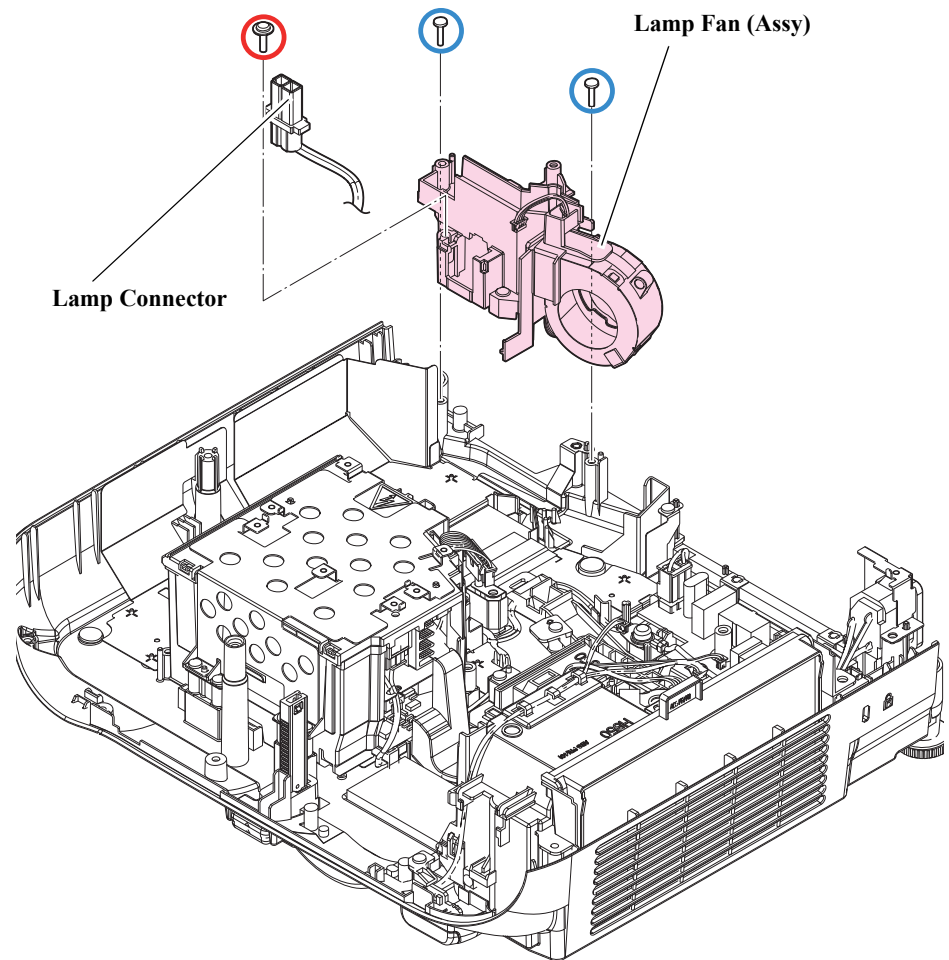

3.3.13.1 Lamp Fan/Speaker 5W

DISASSEMBLY PROCEDURE

1. See *Flowchart (p70)* and remove all parts up to the component below from the projector.
Lamp Fan (Assy) (p120)
 2. Remove the "Lamp Fan" from the "Lamp Connector Holder".
 3. Remove the "Lamp Fan Cushion A" and the two "Lamp Fan Cushion B" from the "Lamp Fan".
- EB-E01/X06/W06/FH06/E10/X51/W51/E20/X49/W49/W52, EH-TW740/TW750
4. Remove the two screws (○) and remove the "Speaker 5W".
- EB-FH06/E20/X49/W49, EH-TW740/TW750
5. Remove the "GND Cable".

■ EB-FH52/972/982W/992F/118, PL 119W

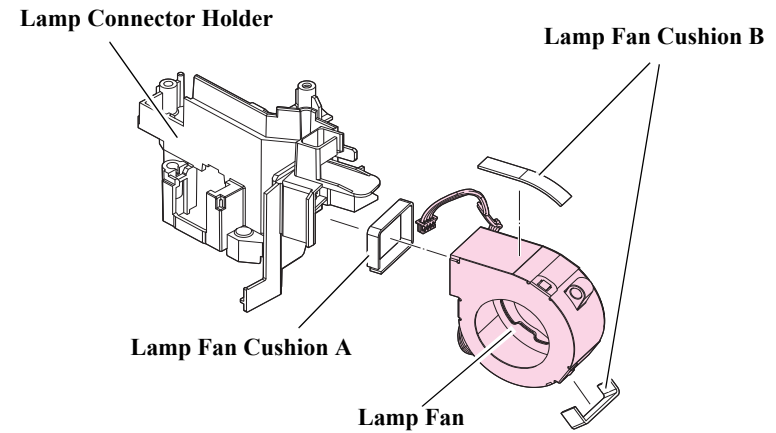

■ EB-E01/X06/W06/FH06/E10/X51/W51/E20/X49/W49/W52, EH-TW740/TW750

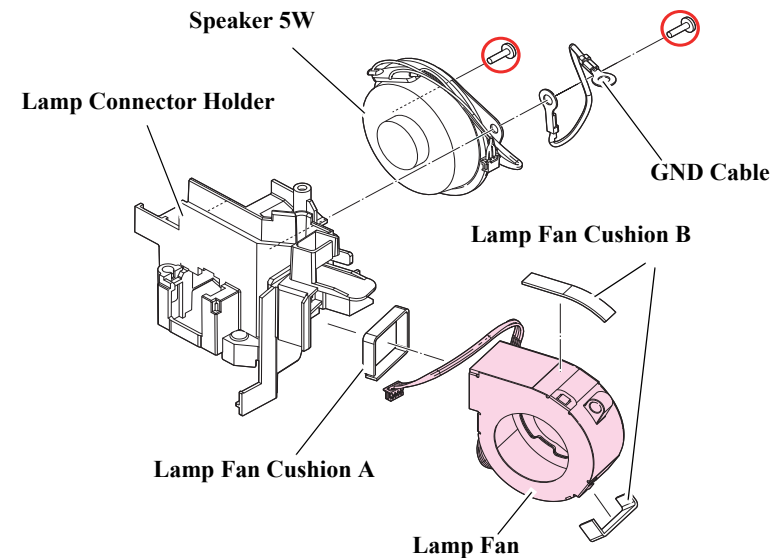

3.3.14 PS Ballast Assy



重点保安部品

This part is designated as the Safety Device. When removing/replacing the part for repair, be sure to refer to [3.5.1 Safety Check after Servicing \(p142\)](#). After serving, follow the procedures specified in the Safety Check after Servicing.

WARNING

- At the area shown below, an electric shock may result if you operate carelessly because there is electric charge remaining to reduce power consumption in the Power Supply.

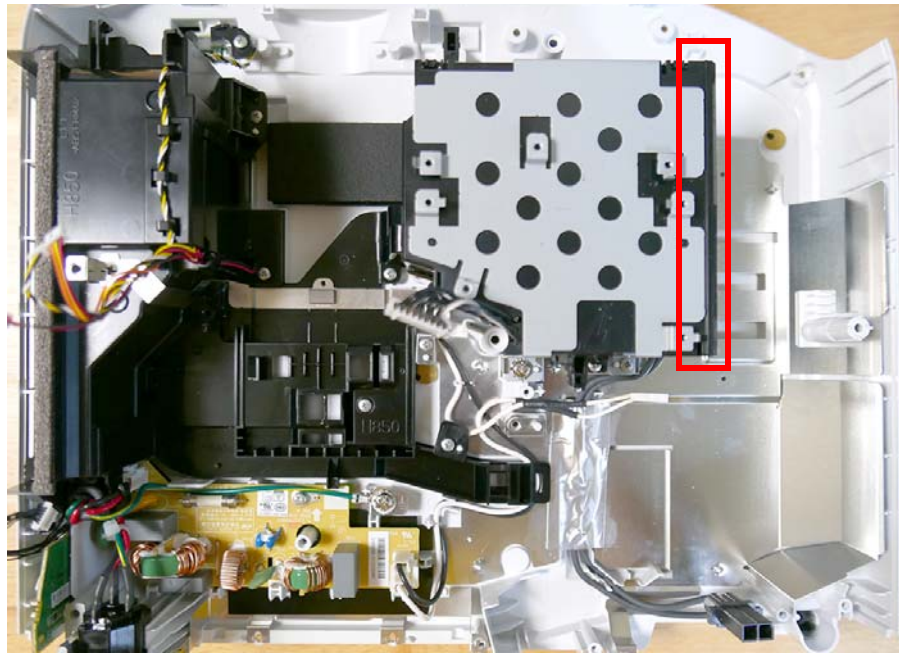

WARNING

- To repair after turning on, extract the charges by the following procedures.
- Press a discharge resistance between the 2pin of T301 and the heat sink for three seconds to discharge.

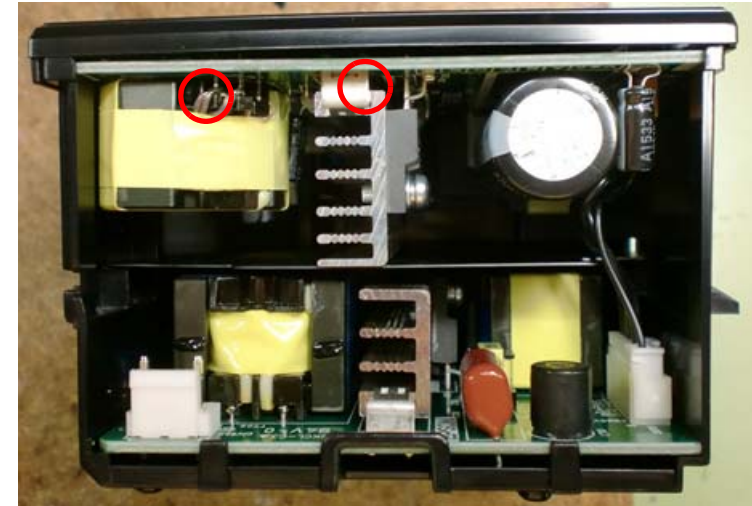
<A Type>

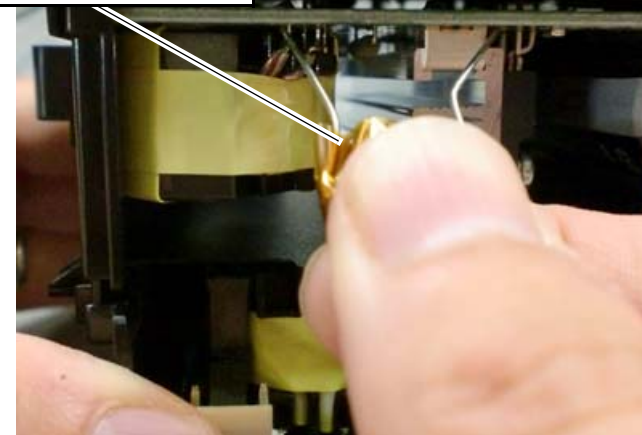

Discharge resistor (1kΩ)



⚠ WARNING

- Press a discharge resistance between the D6002 and the heat sink for three seconds to discharge.

<B Type>

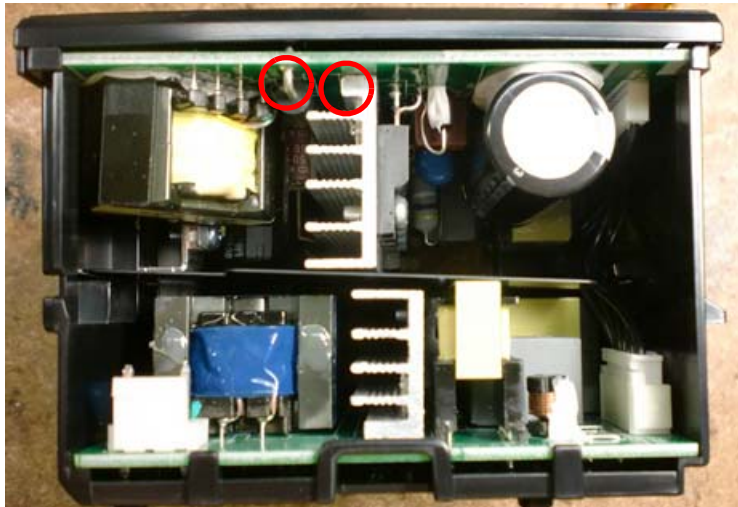

Discharge resistor (1k Ω)

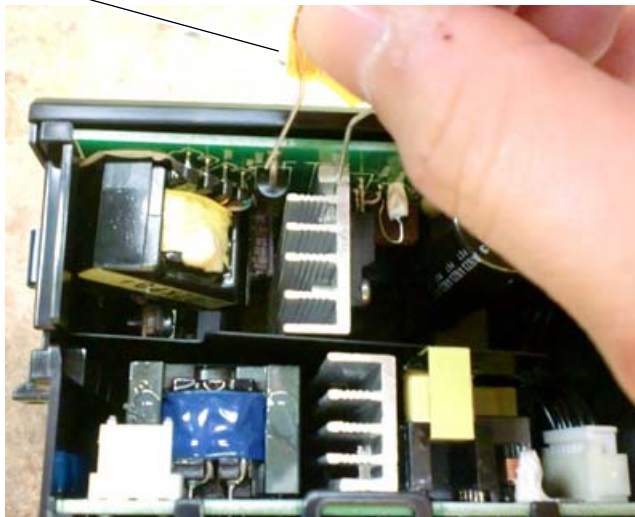



DISASSEMBLY PROCEDURE

□ EB-E01/X06/W06/E10/X51/W51/W52

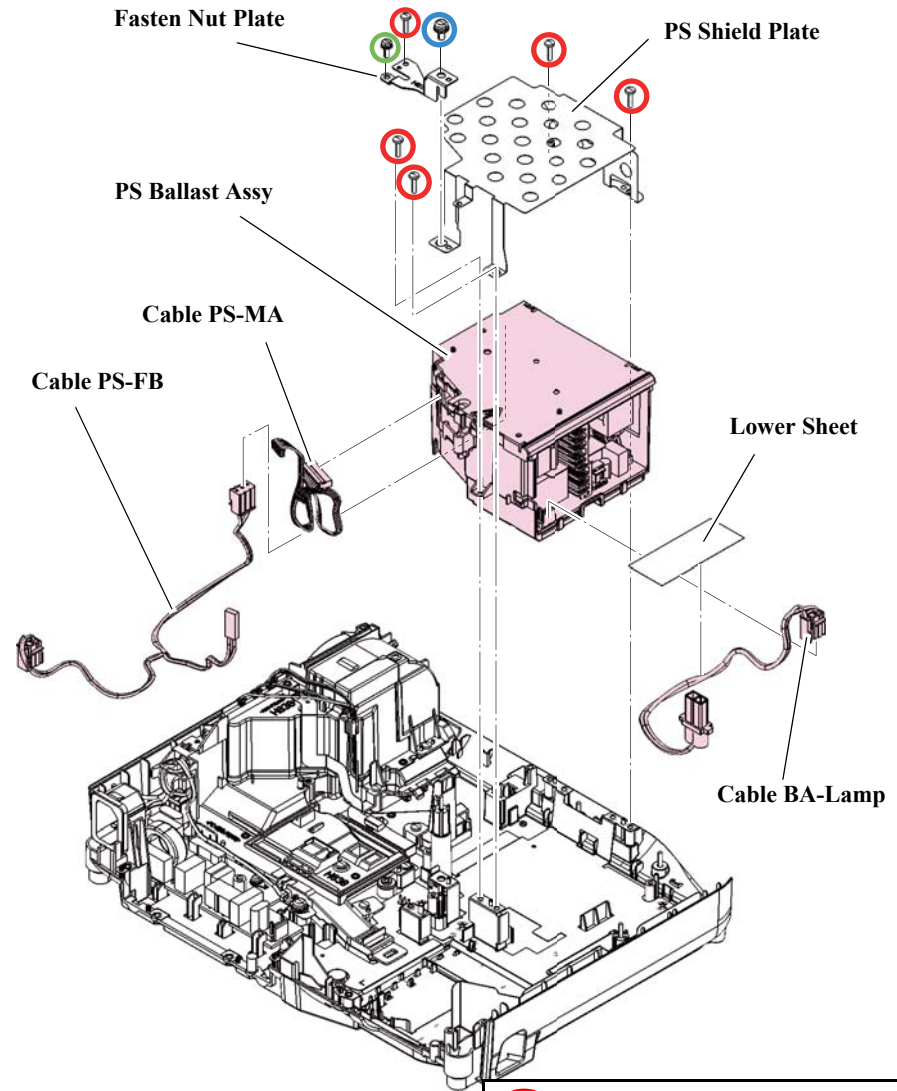
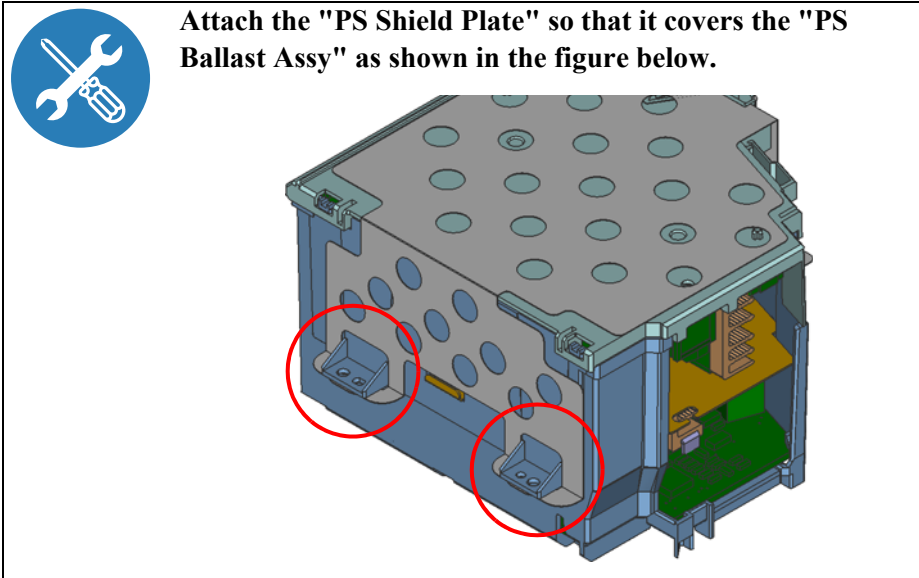
1. See *Flowchart (p70)* and remove all parts up to the component below from the projector.
- Lamp Fan (Assy) (p120)*
2. Remove the three screws (○/○/○) and remove the "Fasten Nut Plate".
3. Remove the "Lower Sheet".
4. Remove the four screws (○) and remove the "PS Ballast Assy" while the "PS Shield Plate" is still attached.
5. Remove the following parts from the "PS Ballast Assy".
 - PS Shield Plate
 - Cable PS-MA
 - Cable PS-FB
 - Cable BA-Lamp





-  C.B.P-TITE SCREW,2.5X10,F/ZN-3C
-  C.P.(O)SCREW,4X6,F/NI
-  C.P.(S-P1)SCREW,3X5,F/ZN-3C

□ EB-FH06/FH52/E20/X49/W49/972/982W/992F/118, PL 119W/
EH-TW740/TW750

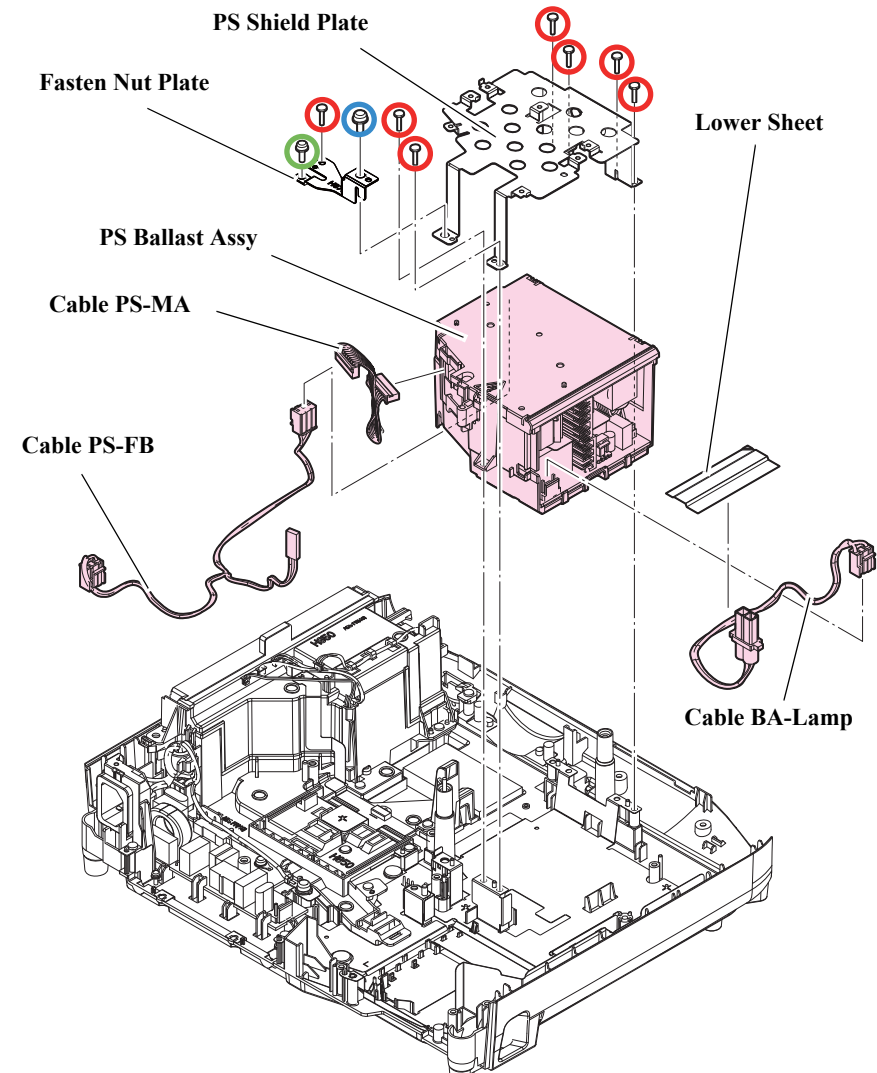
1. See *Flowchart (p70)* and remove all parts up to the component below from the projector.
Lamp Fan (Assy) (p120)
2. Remove the three screws (○/○/○) and remove the "Fasten Nut Plate".
3. Remove the "Lower Sheet".
4. Remove the six screws (○) and remove the "PS Shield Plate" and the "PS Ballast Assy".
5. Remove the following parts from the "PS Ballast Assy".
 - Cable PS-MA
 - Cable PS-FB
 - Cable BA-Lamp



	C.B.P-TITE SCREW,2.5X10,F/ZN-3C
	C.P.(O)SCREW,4X6,F/NI
	C.P.(S-P1)SCREW,3X5,F/ZN-3C



Route the "Cable PS-MA", the "Cable PS-FB", and the "Cable BA-Lamp" as shown below.

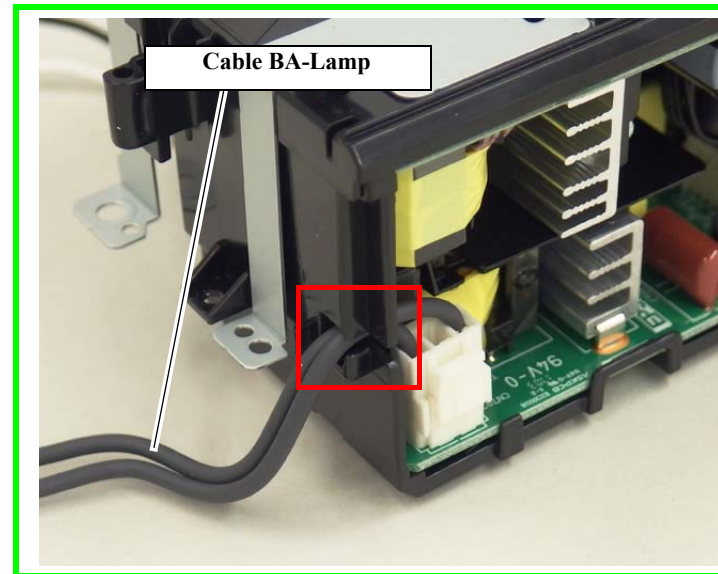
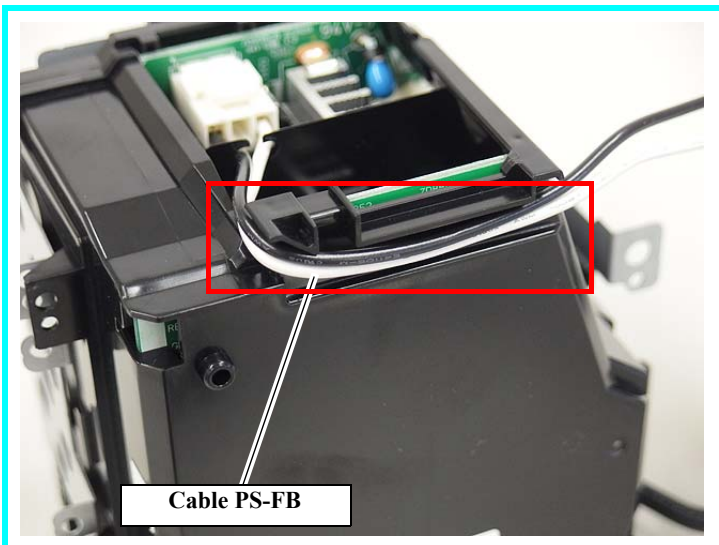
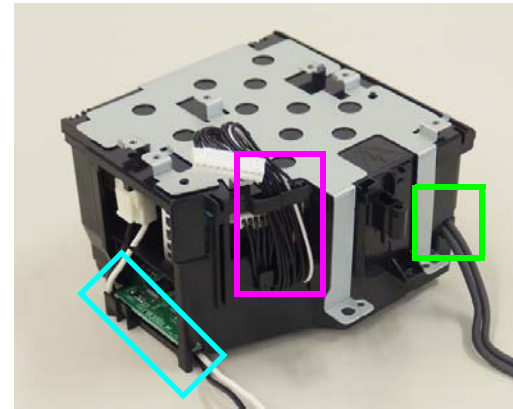
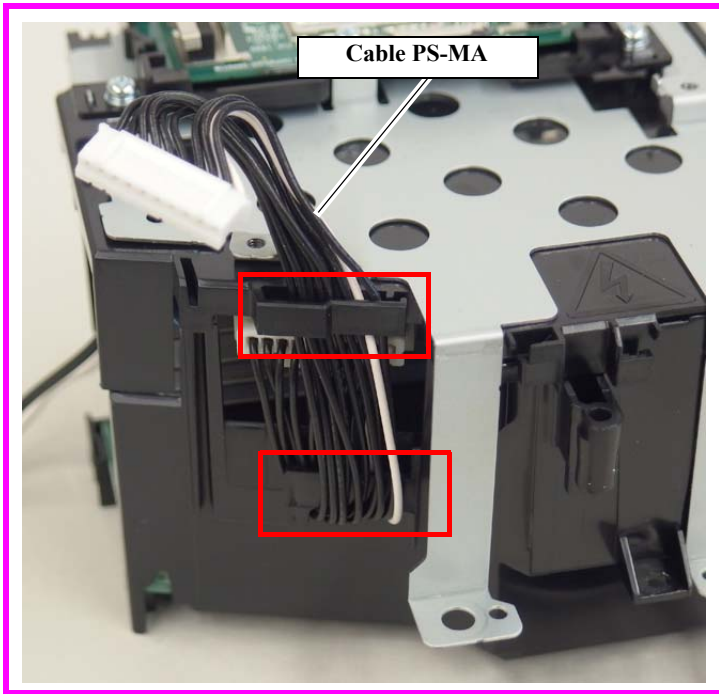

 Hook



Route the "Cable PS-FB" and the "Cable BA-Lamp" to the "Lower Case" as shown in the figure, and affix the "Lower Sheet". Attach the "Fasten Nut Plate" to the position shown in the figure.

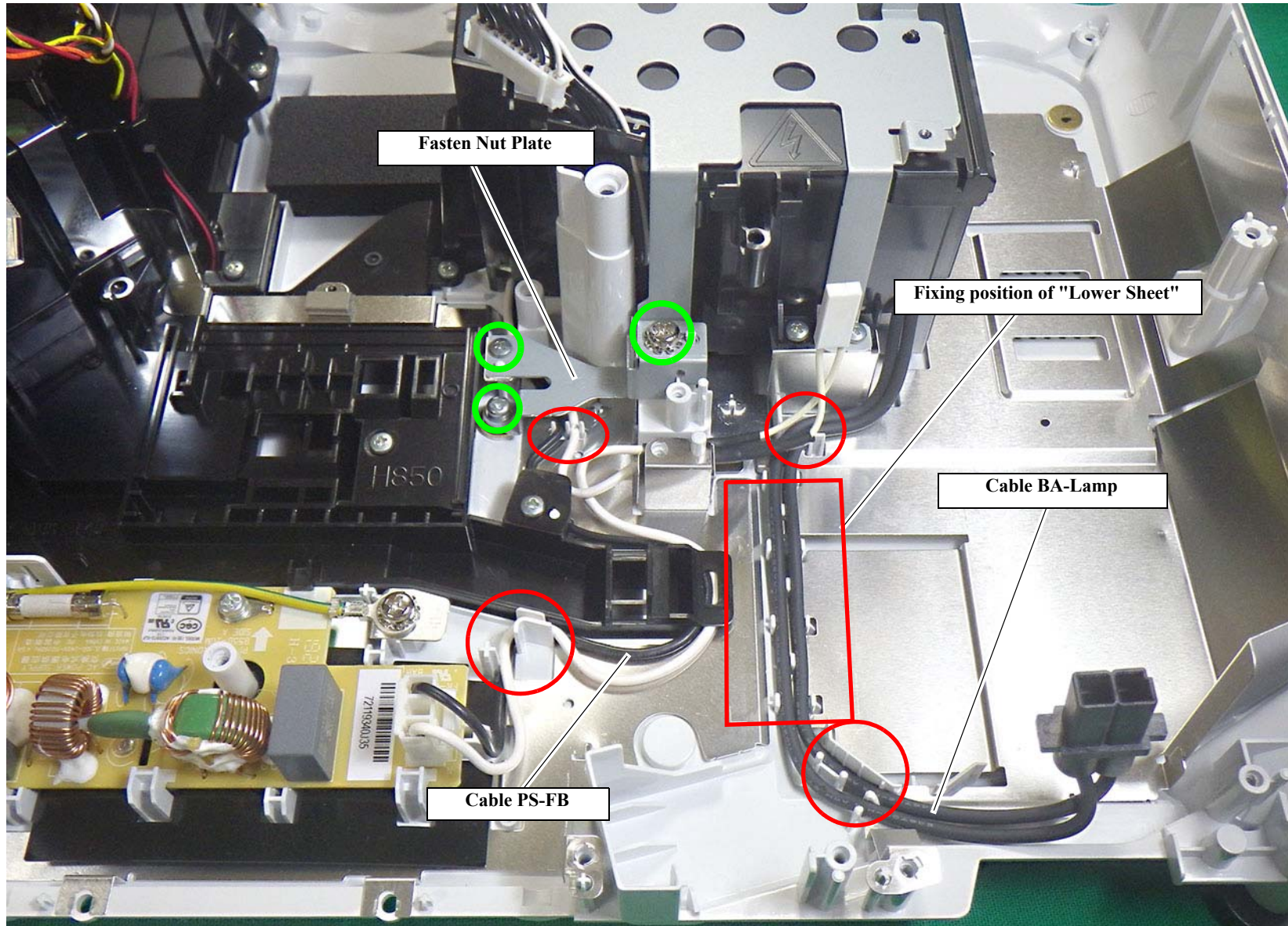

3.3.15 P4combo Module

DISASSEMBLY PROCEDURE

□ EB-FH52/992F/W52, EH-TW750

1. See *Flowchart (p70)* and remove all parts up to the component below from the projector.
INT Duct (Assy) (p129)
2. Remove the two screws (○) and remove the "P4combo Module" and the "FFC 15P".

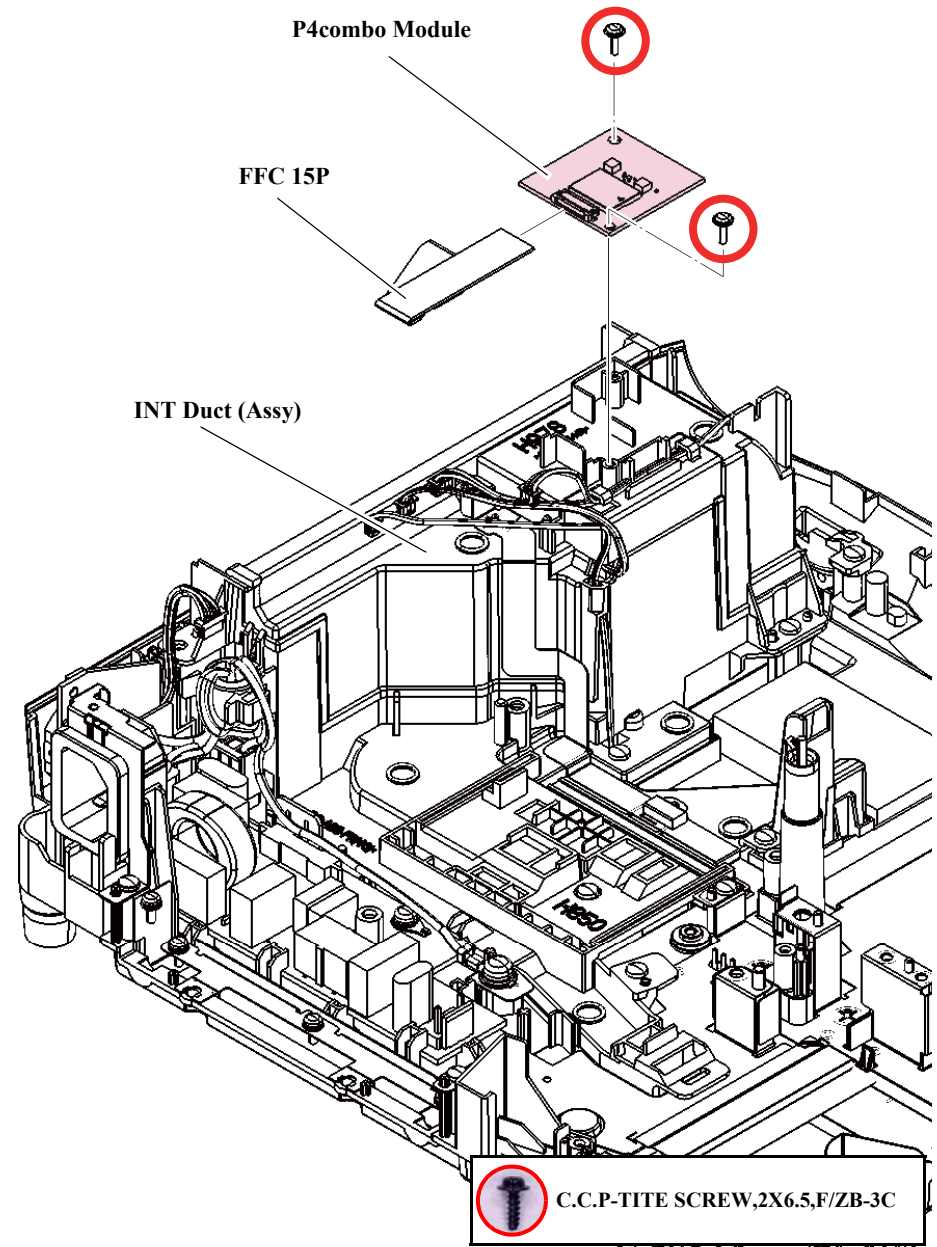
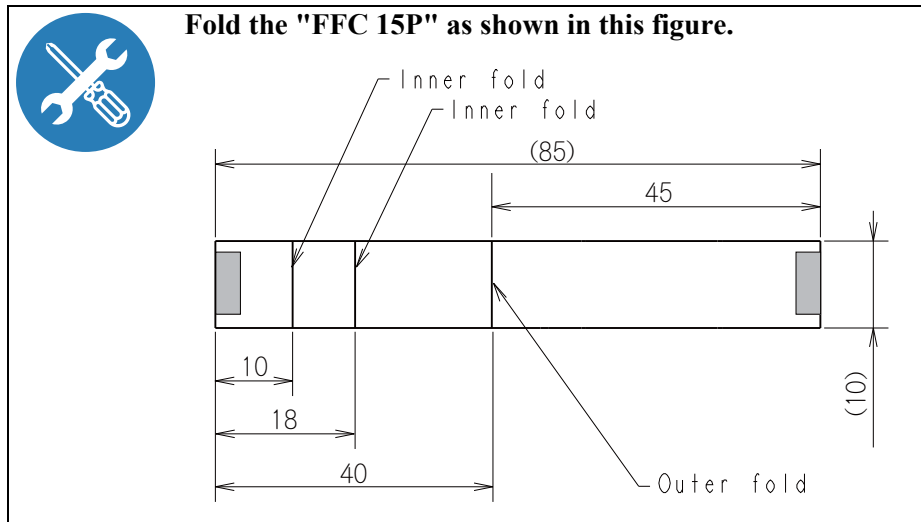

3.3.16 INT Duct (Assy)

DISASSEMBLY PROCEDURE

1. See *Flowchart (p70)* and remove all parts up to the component below from the projector.
Optical Engine (Assy) (p113)
2. Remove the five screws (○) and remove the "INT Duct (Assy)".
3. Remove the following parts from the "INT Duct (Assy)".
 - Lower Conduction Plate
 - Conduction Cushion

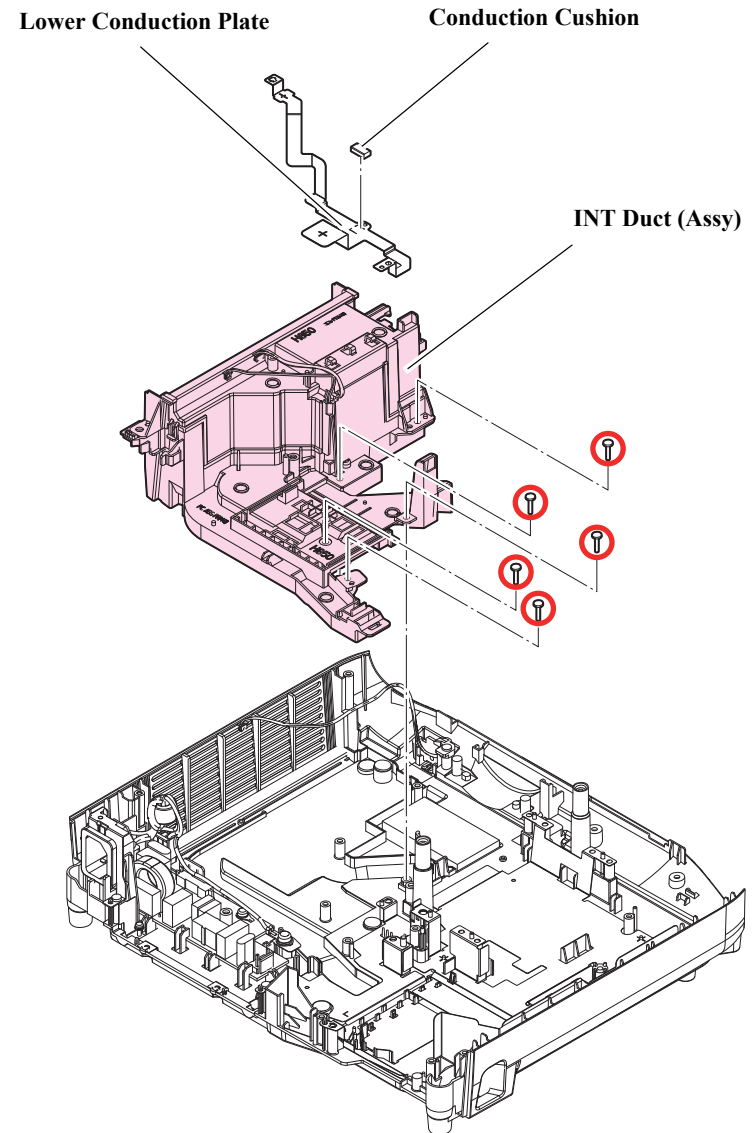
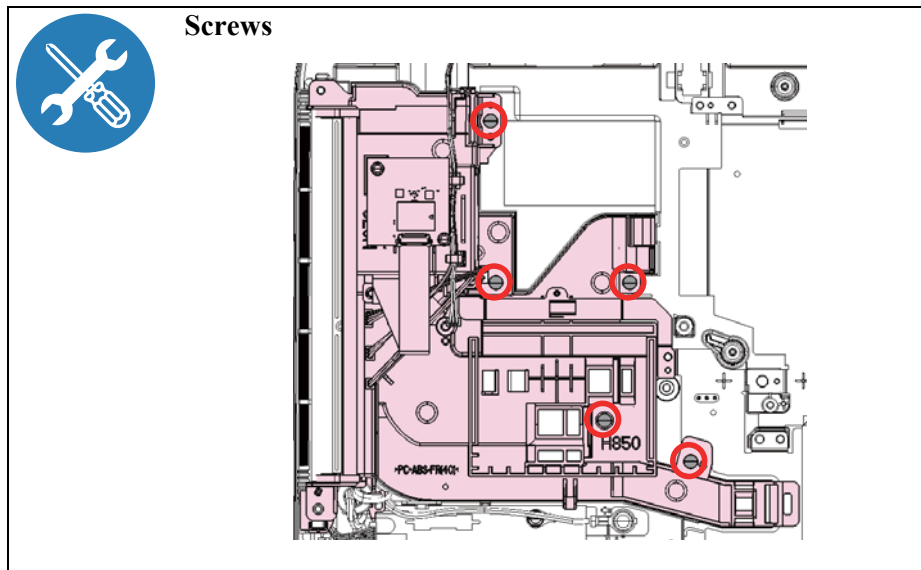



Attach the ferrite core of the "Inlet Cable" as shown in the figure below. Pass the cables from the connector through the hook.



■ EB-FH52/972/982W/992F

Route the "RCF Cable" connected to the "IR Board" on the INT Duct as shown in the figure below.

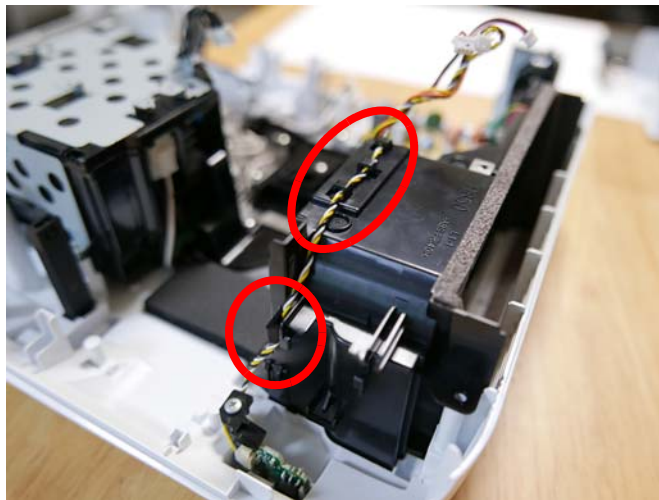

3.3.16.1 IR Board

DISASSEMBLY PROCEDURE

- EB-E01/X06/W06/FH06/E10/X51/W51/W52/E20/X49/W49/118, PL 119W, EH-TW740/TW750
1. See *Flowchart (p70)* and remove all parts up to the component below from the projector.
INT Duct (Assy) (p129)
 2. Remove the screw (⊙) and remove the "IR Board" and the "RCF Cable".



Route the "RCF Cable" connected to the "IR Board" on the INT Duct as shown in the figure below.

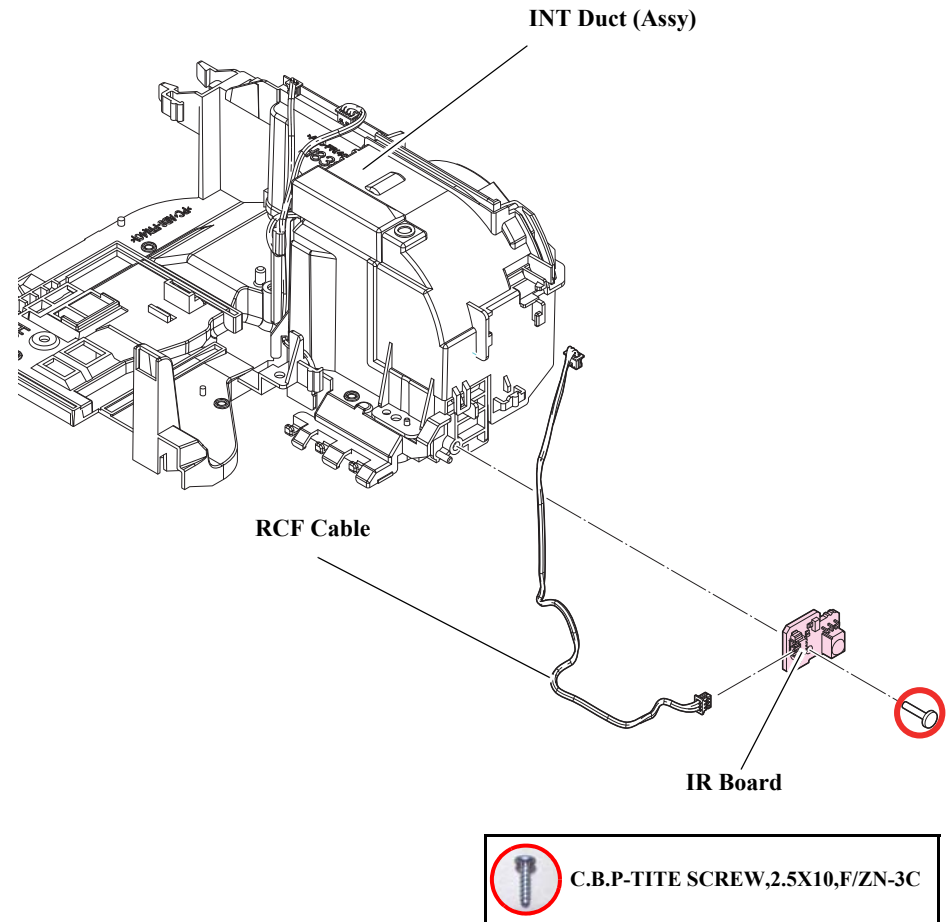
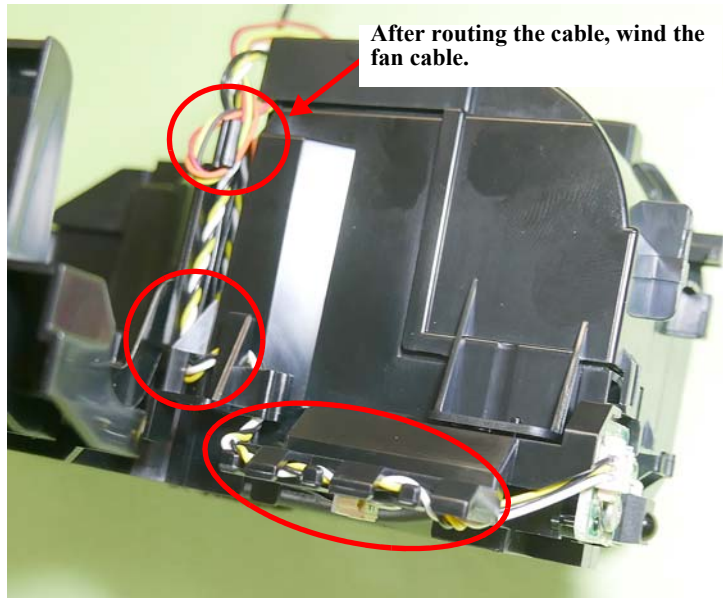

3.3.16.2 INT Fan/TH Board

DISASSEMBLY PROCEDURE

□ EB-FH52/972/982W/992F

1. See *Flowchart (p70)* and remove all parts up to the component below from the projector.
PS Ballast Assy (p122)
2. Remove the screw (○) and remove the "TH Board" and the "TH Cable H309".
3. Remove the "INT Duct B".
4. Remove the following parts from the "INT Duct B".
 - INT Duct Cushion Seal C
 - INT Duct Cushion Seal D x2 pcs
5. Remove the two screws (○) and remove the "INT Fan".
6. Remove the following parts from the "INT Fan".
 - INT Duct Cushion Seal C
 - Cable Fasten Tape x3 pcs

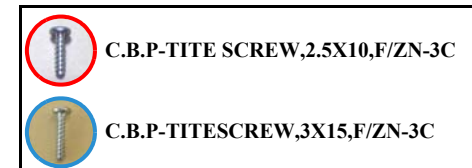
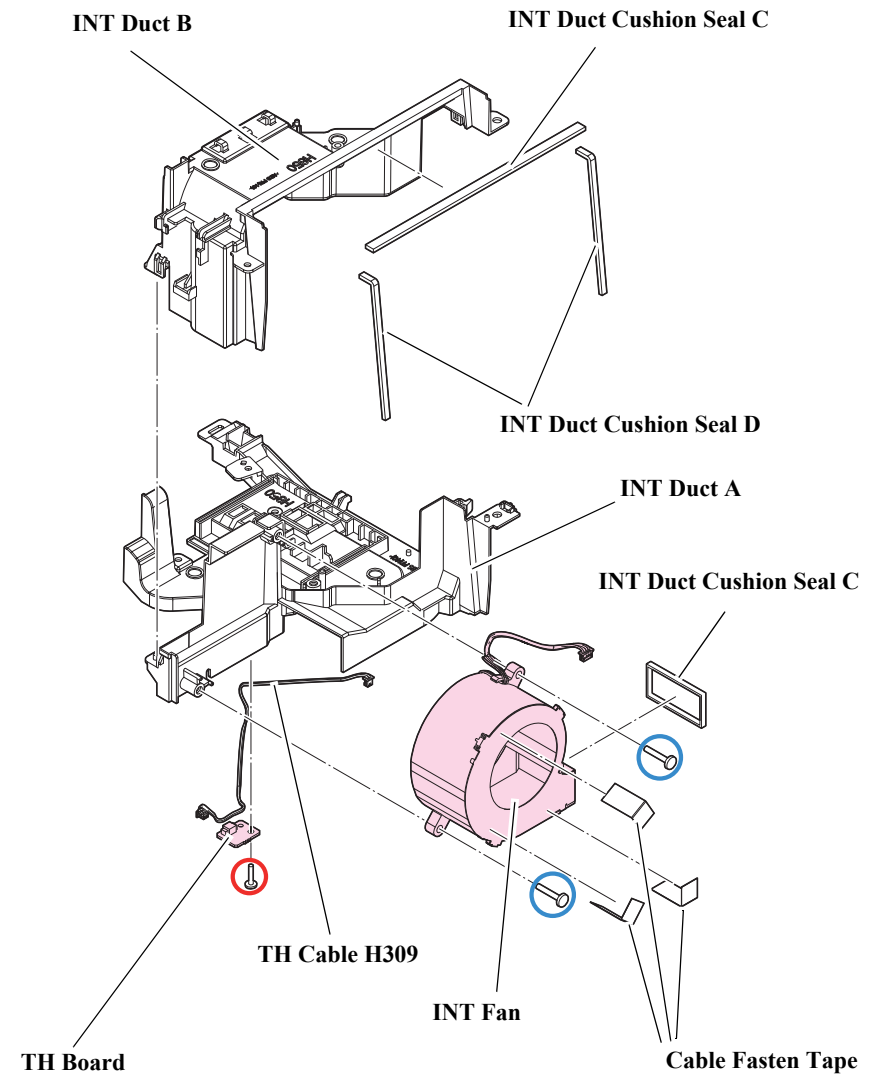

- EB-E01/X06/W06/FH06/E10/X51/W51/W52/E20/X49/W49/118,
PL 119W, EH-TW740/TW750

1. See *Flowchart (p70)* and remove all parts up to the component below from the projector.
PS Ballast Assy (p122)
2. Remove the screw (○) and remove the "TH Board" and the "TH Cable H550".
3. Remove the "INT Duct B".
4. Remove the two screws (○) and remove the "INT Fan".
5. Remove the following parts from the "INT Fan".
 - INT Duct Cushion Seal C
 - Cable Fasten Tape x3 pcs

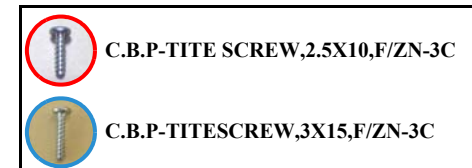
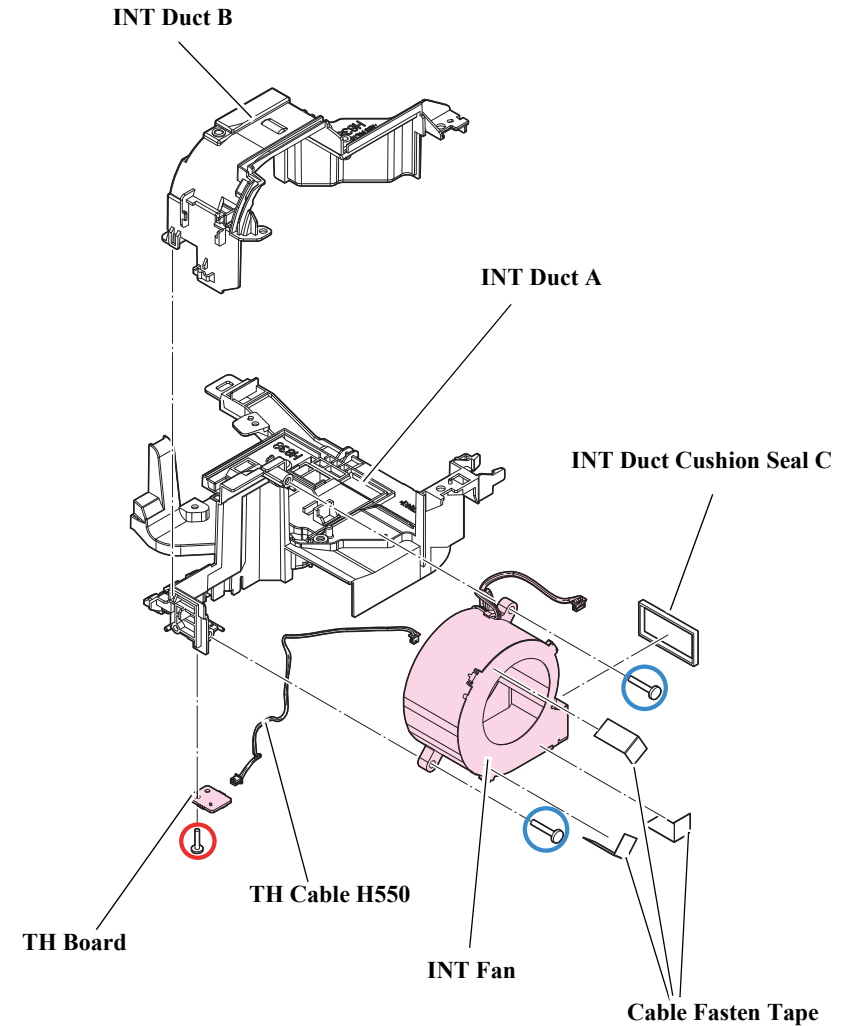



Route the cable as shown below.

- EB-FH52/972/982W/992F

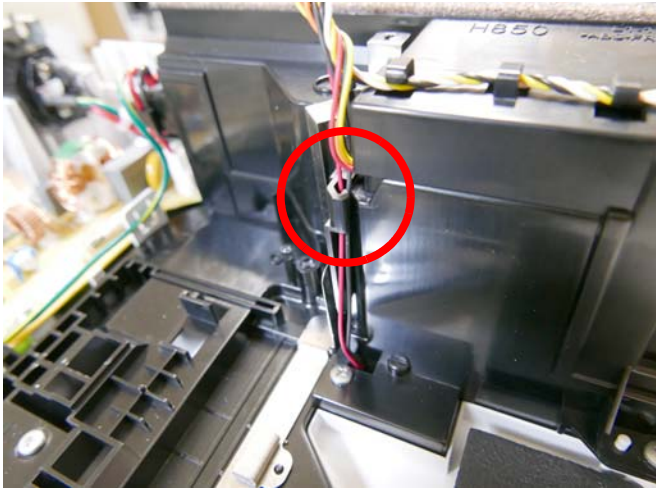

- EB-E01/X06/W06/FH06/E10/X51/W51/W52/E20/X49/W49/118, PL 119W, EH-TW740/TW750

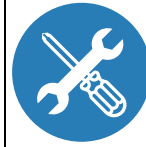
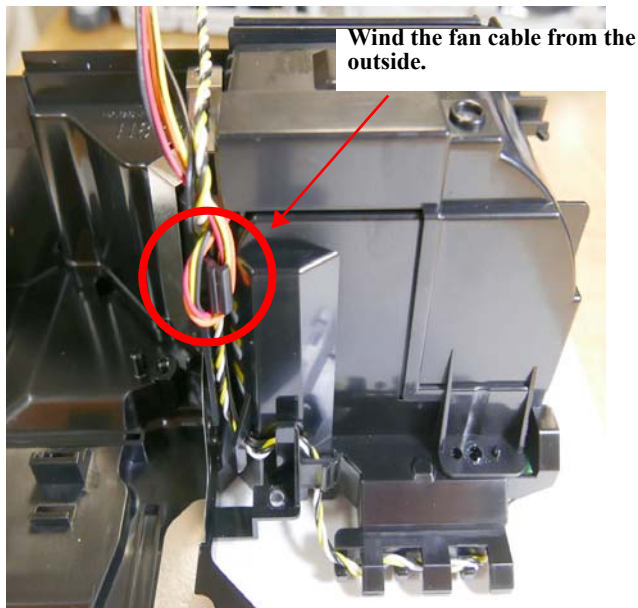

Route the cable of the TH Board as shown in the figure below.

- EB-FH52/972/982W/992F

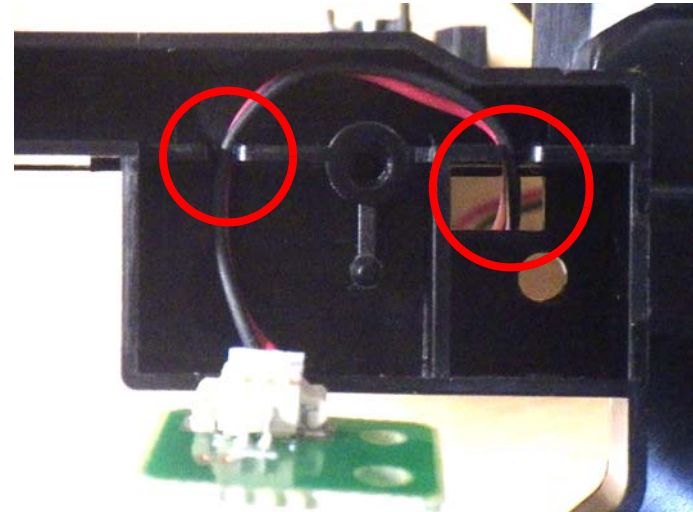

- EB-E01/X06/W06/FH06/E10/X51/W51/W52/E20/X49/W49/118, PL 119W, EH-TW740/TW750

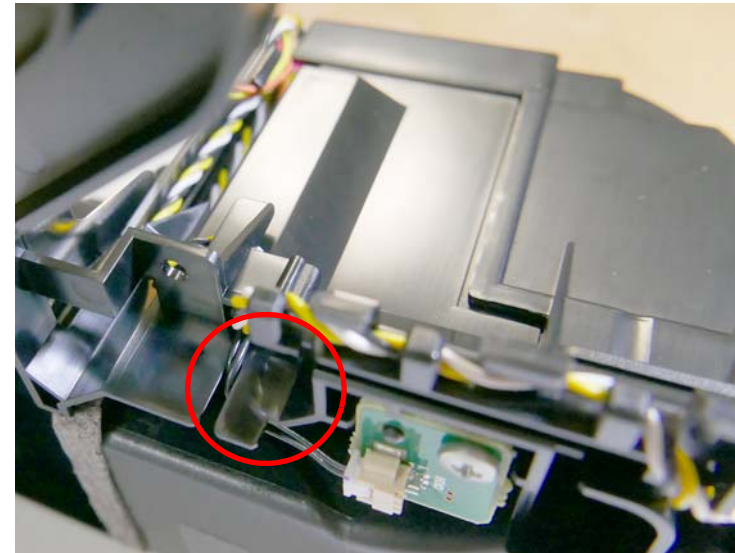

3.3.17 Filter Boards



This part is designated as the Safety Device. When removing/replacing the part for repair, be sure to refer to **3.5.1 Safety Check after Servicing (p142)**. After serving, follow the procedures specified in the Safety Check after Servicing.

DISASSEMBLY PROCEDURE

1. See *Flowchart (p70)* and remove all parts up to the component below from the projector.
PS Ballast Assy (p122)
2. Remove the screw (○) and remove the "Inlet Fasten Plate".
(This procedure is not applicable to EB-E01/X06/W06/E10/X51/W51/W52)
3. Remove the screw (○) and remove the "Inlet Cable".
4. Remove the screw (○), release the hook (□), and remove the "Filter Board" and the "FB Insulation Sheet".

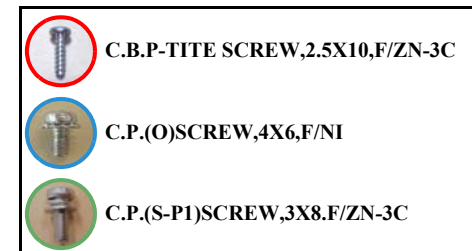
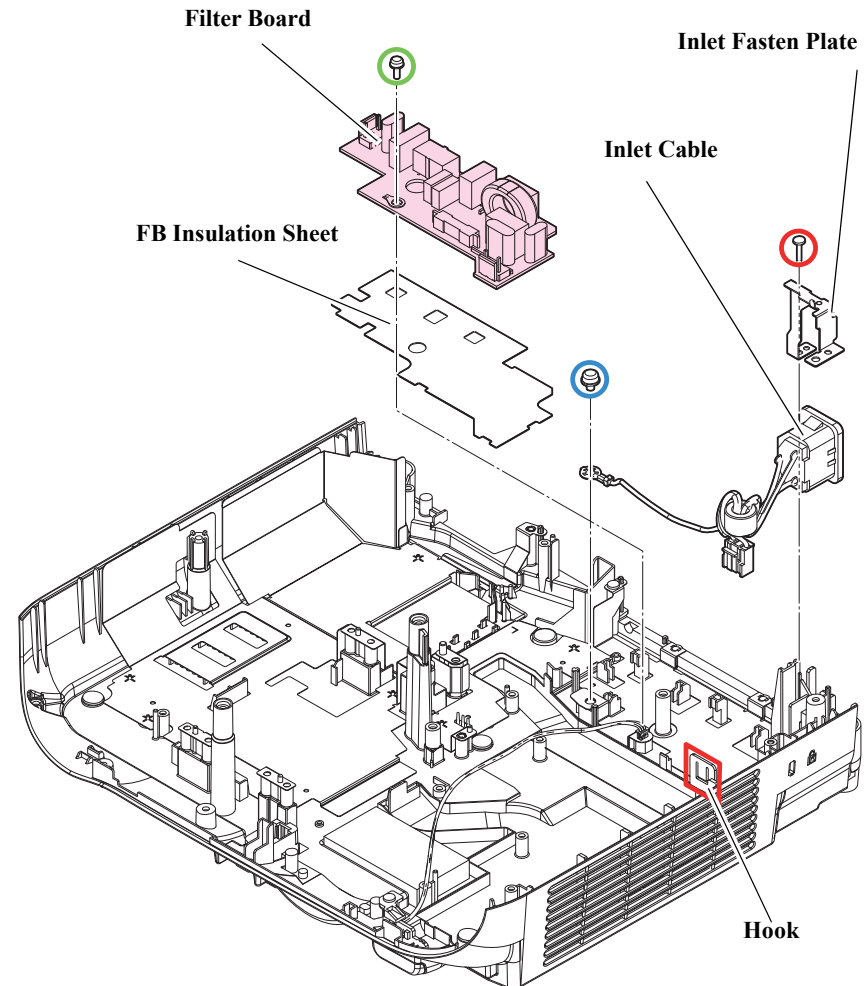

3.3.18 Lower Case/IR Board

DISASSEMBLY PROCEDURE

- See [Flowchart \(p70\)](#) and remove all parts up to the component below from the projector.
[Filter Boards \(p135\)](#)
 - Remove the screw (○) and remove the following parts:
(EB-FH52/972/982W/992F)
 - PS Holder
 - IR Board
 - RCF Cable
 - Remove the following parts from the "Lower Case".
 - Lower Shield Plate A
 - Lower Shield Plate B
 - RC Filter
 - 6N-A,4,B/NI x2 pcs (○)
 - H.N.-3,3,F/ZN-3C(○)
- EB-FH52/972/982W/992F only
- Lower Cushion Seal
 - Lower Cushion



Be careful while routing as the parts shown in the figure are easily breakable.

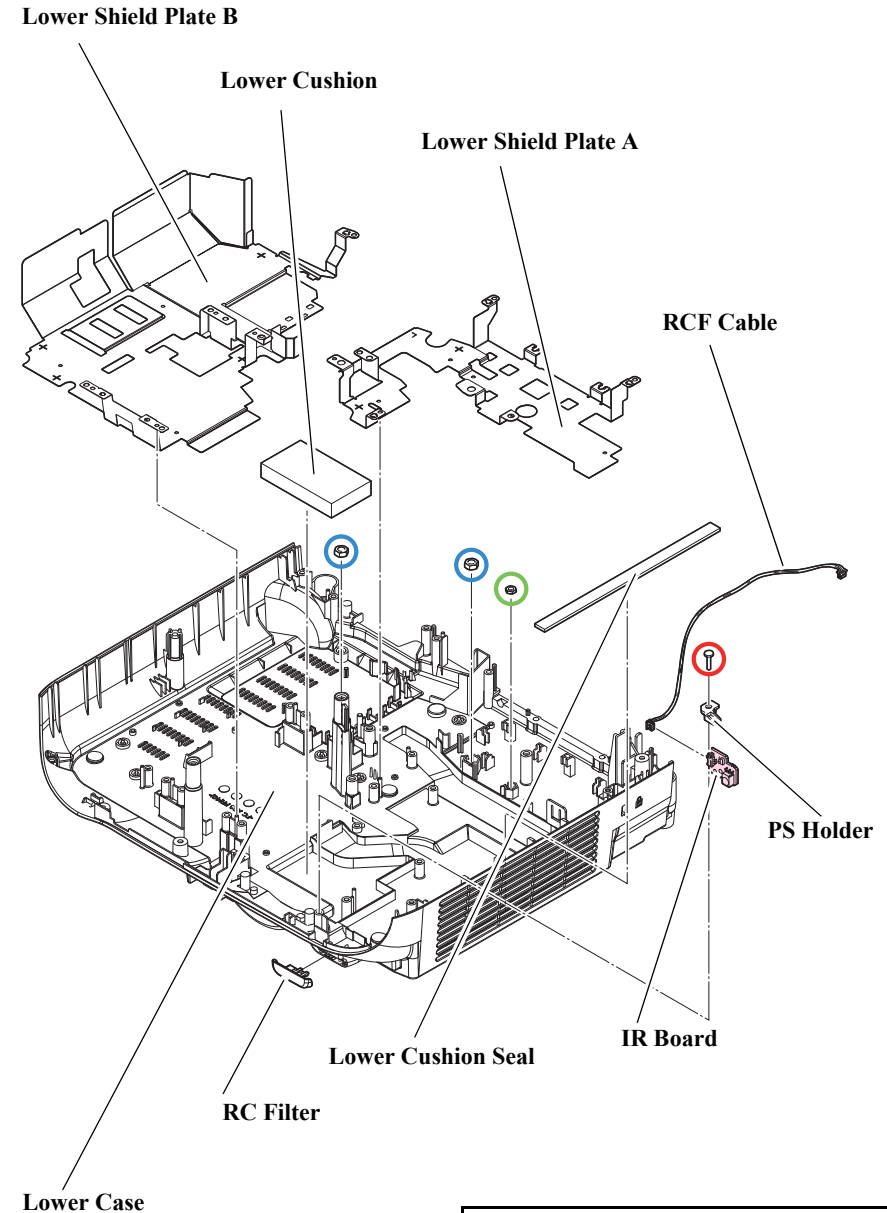
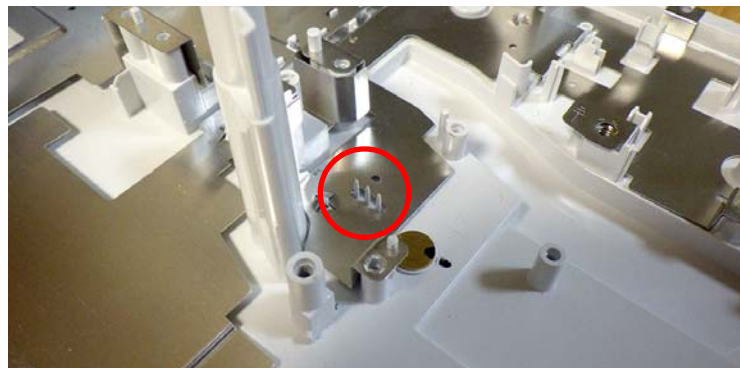

3.4 Shortest removal procedures of identified failed parts

If you can identify a failed part, the following parts can be removed in shortest ways different from the ordinal disassembling procedures.

3.4.1 Speaker

PART NAME

- Speaker 5W
(EB-E01/X06/W06/FH06/E10/X51/W51/W52/E20/X49/W49, EH-TW740/TW750)
- Speaker 16W
(EB-FH52/972/982W/992F/118, PL 119W)

DISASSEMBLY PROCEDURE

1. See [Flowchart \(p70\)](#) and remove all parts up to the component below from the projector.
[Upper Case \(Assy\) \(p80\)](#)
2. Remove the two screws (○) and remove the "Speaker 5W".
(EB-E01/X06/W06/FH06/E10/X51/W51/W52/E20/X49/W49, EH-TW740/TW750)
3. Remove the four screws (○) and remove the "Speaker 16W".
(EB-FH52/972/982W/992F/118, PL 119W)

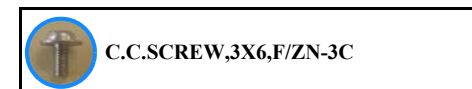
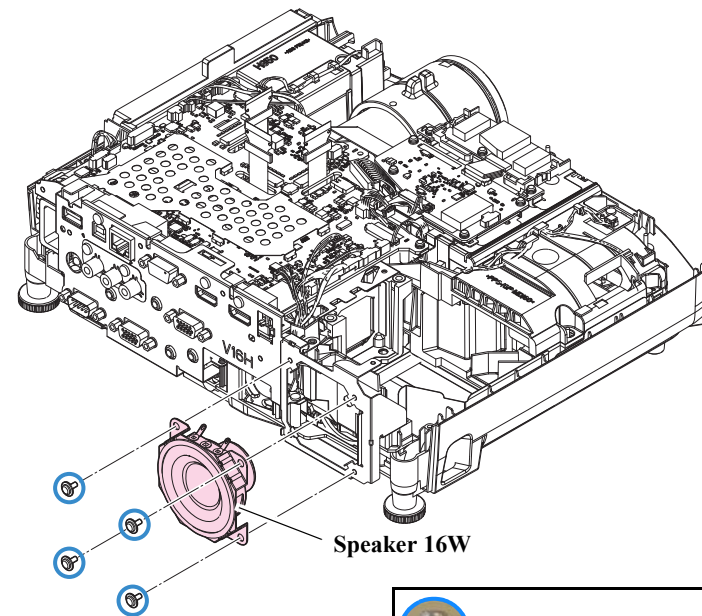
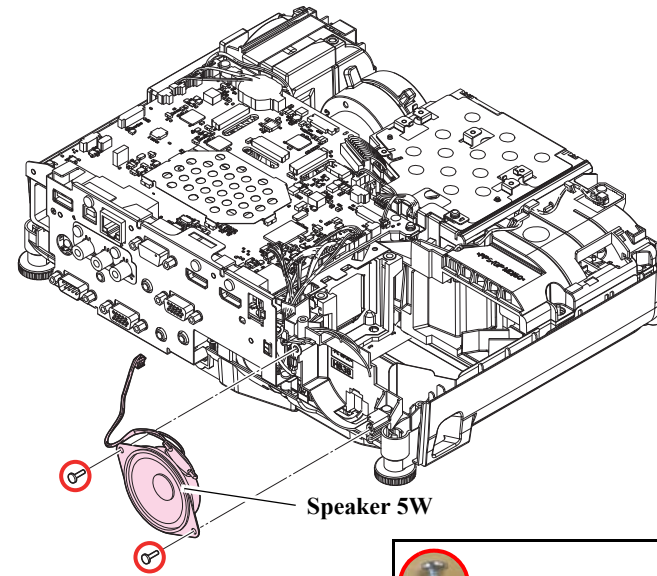

3.4.2 IR Board

PART NAME

- IR Board
(EB-FH52/972/982W/992F)

DISASSEMBLY PROCEDURE

1. See *Flowchart (p70)* and remove all parts up to the component below from the projector.
Upper Case (Assy) (p80)
2. Remove the connector of the cable from the "IR Board".
3. Remove the screw (○) and remove the "PS Holder" and the "IR Board".

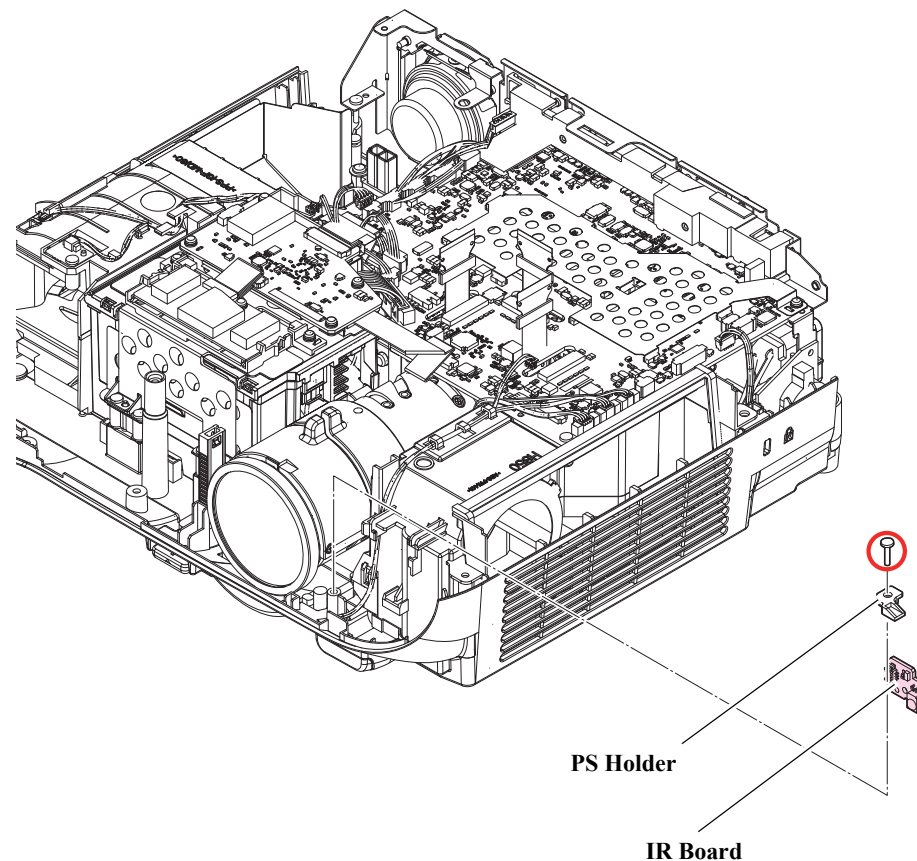

3.4.3 LMP Thermistor

PART NAME

TH Board

DISASSEMBLY PROCEDURE

1. See *Flowchart (p70)* and remove all parts up to the component below from the projector.
Upper Case (Assy) (p80)
2. Remove the connector of the "TH Cable H838" from the "TH Board".
3. Remove the screw (○) and remove the "TH Board".

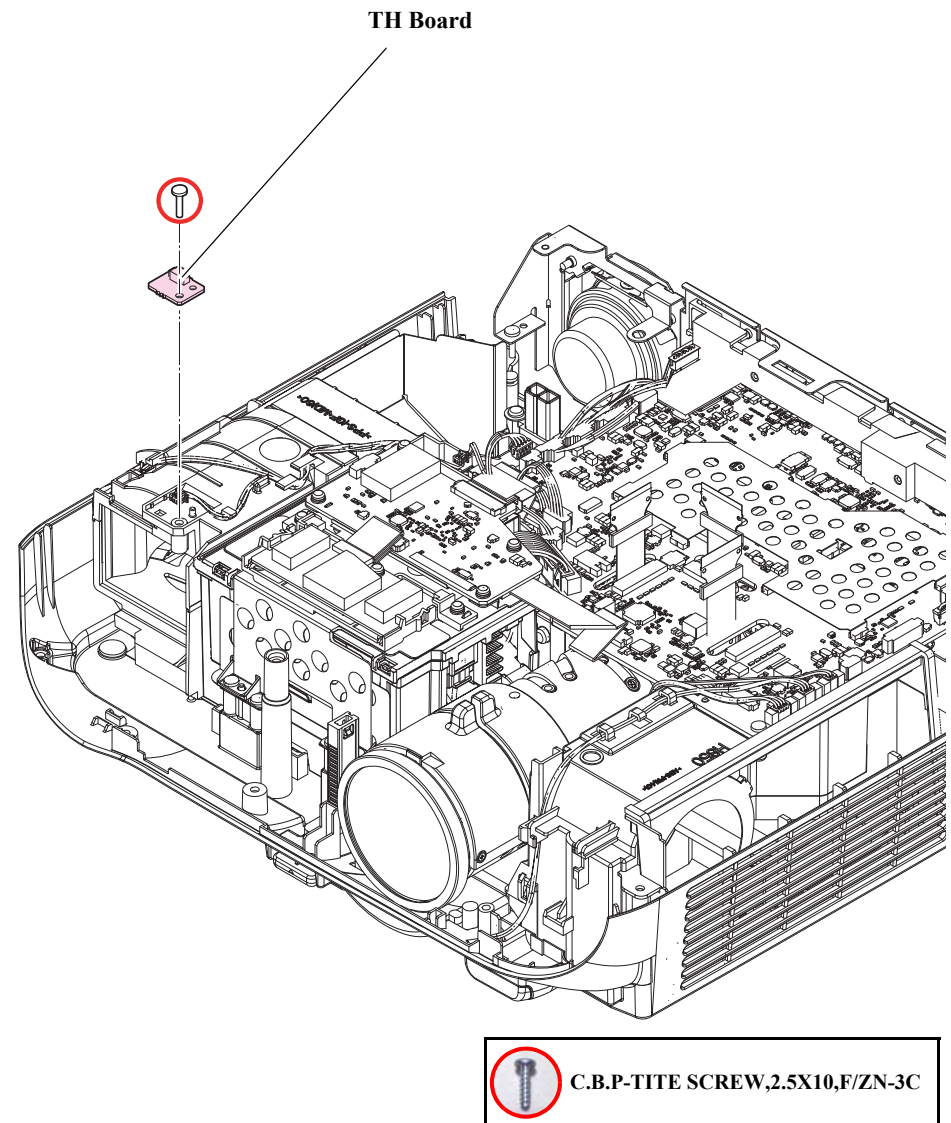

3.4.4 EX Fan

PART NAME

EX Fan

DISASSEMBLY PROCEDURE

1. See [Flowchart \(p70\)](#) and remove all parts up to the component below from the projector.
[MA Board Assy \(p100\)](#)
2. Remove the two screws (○) and remove the "Upper EX Duct".
3. Remove the "EX Fan".

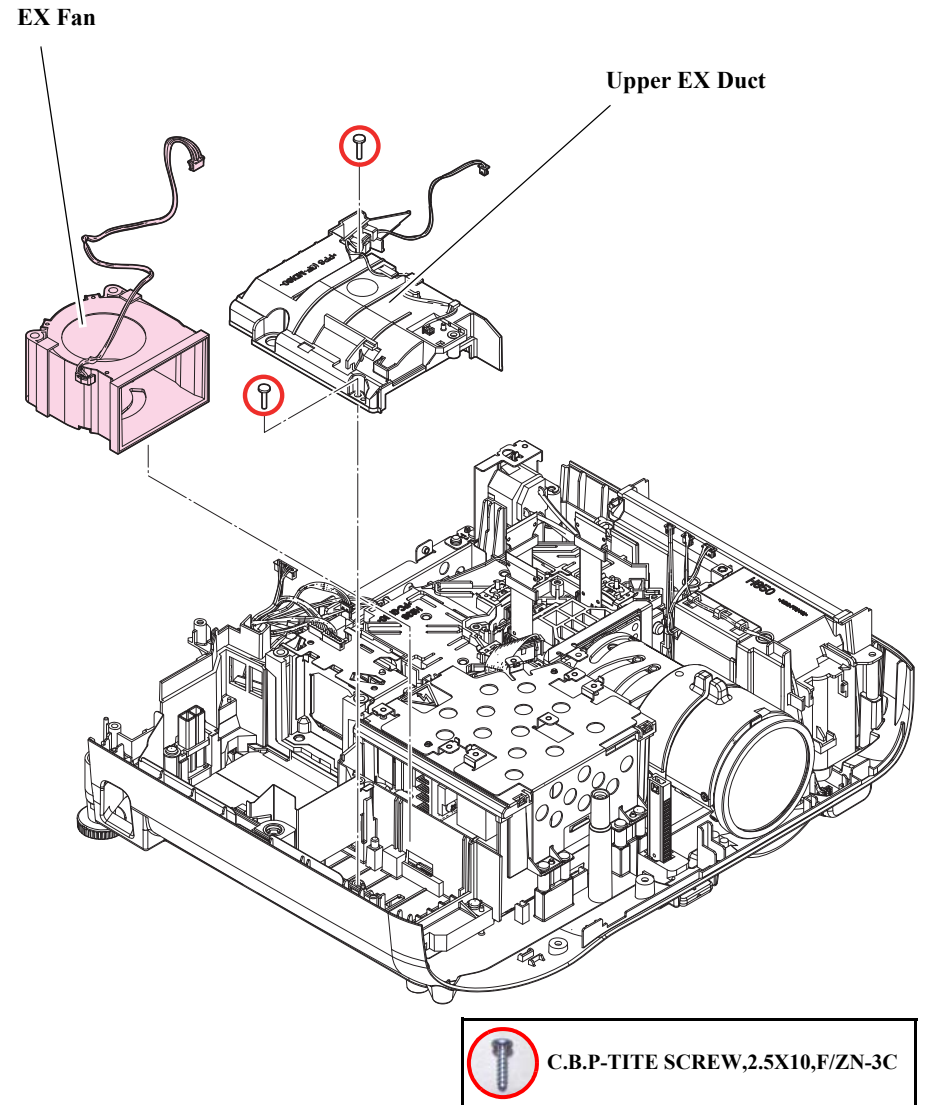

3.5 Individual Function Check After Repair

After performing repair work such as parts replacement of this projector, or disassembling/reassembling the projector, carry out the safety check and the basic operation check of the functions of the projector following the instructions in this section.

REPAIRING PART - OPERATION AND SAFETY CHECK AFTER REPAIR TABLE

When repairing the part indicated as "Repairing part" in the left column on the table, operate the work marked with "o".

The work indicated on the table is the basic items. Put necessary work into effect additionally according to the situation of the repaired product.

Repairing part	Operation and Safety Check						
	Safety Check	Initialization Check	Operation Check for Control Panel	Operation Check for Remote Controller	Operation Check for Video Input/Output	Operation Check for Audio Input/Output	Communication Check
Power Button		o	o				
Remote Controller		o		o			
Video Input/Output		o			o		
Audio Input/Output		o				o	
Safety Device	o	o	o	o	o	o	
MA Board		o					
Optical engine		o					o
Communication							o
Reference	P.142	P.145	P.145	P.145	P.146	P.146	P.147

3.5.1 Safety Check after Servicing

To maintain the safeness of the projector whose safety devices are replaced or which is disassembled and reassembled, make sure to carry out the safety check following the instructions in this section after performing repair work.

SAFETY DEVICE/FUNCTIONS ARE:

- The parts that become unsafe if their specifications or functions are nonconforming.
- The parts that require attention to the safety precautions of the customer.

The parts that are designated by the public safety regulations or the like.

UNSAFE STATE:

“Unsafe state” is the state of a part that may cause or contain the risk of the following:• Personal injuries• Damages to the property• Abnormal heat generation• Smoking• Fire• Explosion• Damage to the part to be installed• Disturbance to/from the peripheral device (EMC disturbance)• Chemical substances regulated by the law

THE SAFETY CONTROL POINTS ARE:

- The processes that Safety Devices/Functions are manufactured, or checked.
- The processes that require the management to maintain the workers' safety.

SAFETY DEVICES/FUNCTIONS OF THIS PRODUCT

- PS Ballast Assy (p122)
- Filter Boards (p135)
- Caution Label Sheet (p93)

TEST ITEMS

- Insulation resistance test
- Ground continuity check
- Illumination check

PROCEDURE

Carry out the check in the order given below.

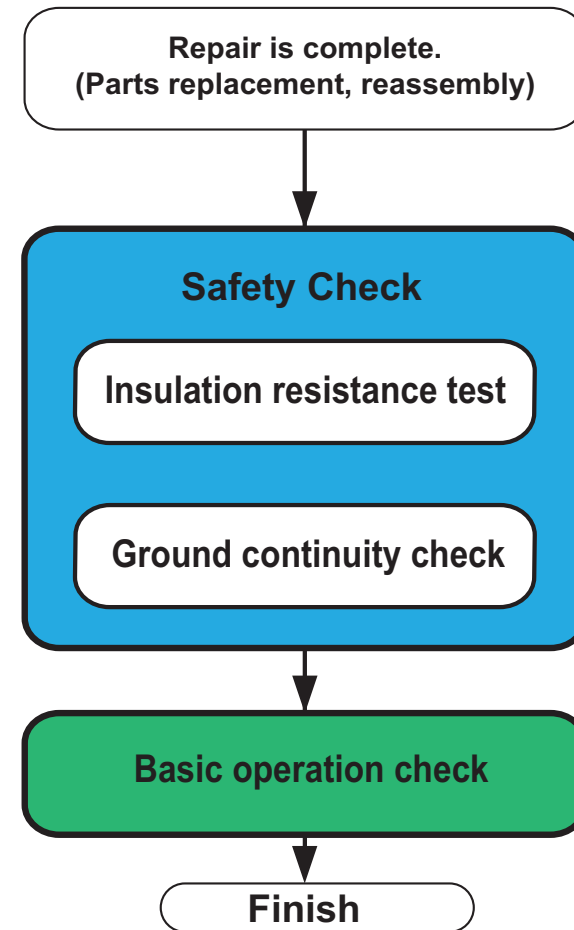

3.5.1.1 Insulation resistance test

Testing apparatus

Insulation ohmmeter (Rating: 500 V/100 MΩ)

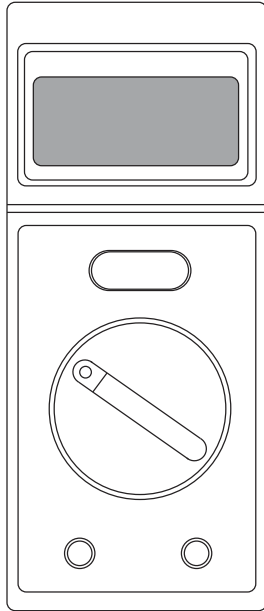

- Measurement range: Select "500 V"
- Tester lead wires:
 - Black lead wire: Connect it to the "EARTH" terminal.
 - Red lead wire: Connect it to the "LINE" terminal

Standard/Judgment level

Insulation resistance should be 10 MW or more.

Testing procedure



Because high voltage (500 V) is present, do not touch the probe during testing.

1. Connect the crocodile clip of the black lead wire to "C" of the projector's Computer terminal.
2. Put the probe of the red lead wire to "A" on the AC inlet of the projector.
3. Set the measure switch to LOCK, and wait for one minute.
4. Measure the insulation resistance between "A" and "C" (1) after one minute.
5. Check that the insulation resistance after one minute is 10 MΩ or more.
6. Measure the insulation resistance between "B" and "C" (2) in the same way as for (1).
7. Check that the insulation resistance of (2) after one minute is 10 MΩ or more.

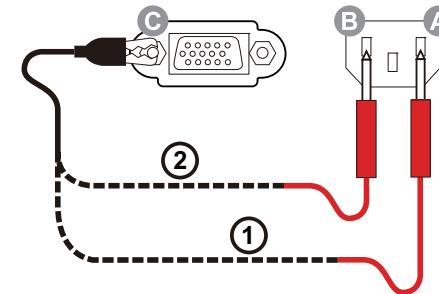

3.5.1.2 Ground continuity check

- Testing apparatus

Multimeter (with sensitivity down to 0.1Ω)

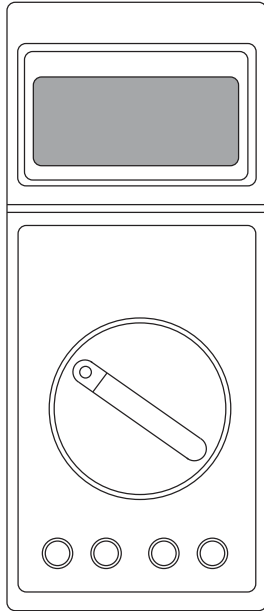

- Measurement range: Select " Ω "
- Tester lead wires:
 - Black lead wire: Connect it to the "COM" terminal.
 - Red lead wire: Connect it to the "V/ Ω /Hz" terminal.

- Standard/Judgment level

Should be no resistance (0.5Ω or less)

- Testing procedure

1. Turn the tester on.
2. Check that the resistance between "C" of the Computer terminal and "G" of the AC inlet of the projector (1) is 0.5Ω or less.

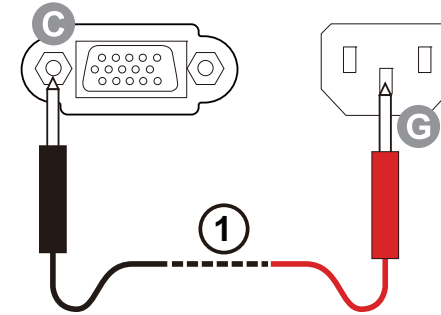

3.5.1.3 Illumination check

- Test conditions

Input a PC or video signal and check the illumination for about 5 minutes.

1. Judgment
 - Projector should operate normally with no smoke or fire.

3.5.2 Initialization

After repairing this product, carry out the following initialization check. When repairing a Safety Device, refer to "[3.5.1 Safety Check after Servicing \(p142\)](#)" and carry out the necessary procedure for safety.

Procedure	Check items
1. Connect the power cable.	Does the [Power] LED light blue?
2. Press the [Power] button on the projector to turn it on.	Does the [Power] LED flash blue, then light blue?
	Does the lamp light?

3.5.3 Operation Check for control panel

After replacing/removing the control panel, carry out the check below following the instructions. (See "[Troubleshooting on Operation Abnormality \(p49\)](#)")

Procedure	Check items
1. Press the [Power] button on the projector to turn it on. 2. Check each button on the control panel if it works properly.	Does the [Power] button switch on/off the projector?
	Does the [Source Search] button switch the sources?
	Does the [Home] button display/close the home screen?
	Does the [Menu] button display/close the menu?
	Is the screen corrected to the standard with the [H/V] button?
	Does the [Esc] button stop the current function?

3.5.4 Operation Check for remote controller

After repairing the remote controller, carry out the check below following the instructions. (See "[Troubleshooting on Operation Abnormality \(p49\)](#)")

Procedure	Check items
Press the [Power] button on the remote controller to turn the projector on.	Does the [Power] button on the controller switch on/off the projector?

3.5.5 Operation Check for video input/output

After repairing the parts related with audio input/output, carry out the check below following the instructions.

Procedure	Check items
1. Set the projector on an even workbench.	Does the lamp light?
2. Press the [Power] button to turn the power ON.	Is the image projected after the lamp lit?
3. Adjust the projection angle with the Foot.	Is "No Signal" message displayed on the screen?
4. Adjust the focus with the Focus Ring.	Are focusing available?
5. Adjust the zoom with the Zoom Ring.	Do the rings smoothly work and focus correctly?
6. Remove the strain using the horizontal correction slider. (Or else, use the [H/V] button on the remote controller to remove the strain.)	Is the image of the selected input source projected?
7. Connect all the IF cables and display an image..	Is image vivid enough?
8. Press the [Source Search] button, and select the corresponding source.	Is the image turned on/off?
9. Check the [A/V Mute] function by opening/closing the Shutter.	
10. Check the [A/V Mute] function by pressing the [A/V Mute] button on the remote controller.	

3.5.6 Operation Check for audio input/output

After repairing the parts related with audio input/output, carry out the check below following the instructions.

(See "[TroubleShooting on Audio Input/Output \(p48\)](#)")

Procedure	Check items
1. Connect your PC to video and audio input terminals of the MA Board.	Does sound come out from speaker?
2. Press the [Source Search] button and switch to the corresponding source.	
3. Input audio signal to the projector from your PC, and output sound from the built-in speaker.	Can you control the volume with the volume buttons on Remote Controller?
4. Check the [A/V Mute] function by opening/closing the Shutter.	
5. Check the [A/V Mute] function by pressing the [A/V Mute] button on the remote controller.	Does sound stop/play with image?

3.5.7 Communication Check

After replacing the parts related with communication, carry out the check below following the instructions.

Procedure	Check items
1. See User's Guide.	Do images and sound outputted from the projector?

3.5.8 Internal Cable Connection Check



Before starting the check, be sure to turn OFF the power switch and pull out the power cable from the projector.

When replacing/removing/repairing the MA Board, make sure to confirm all the cables are connected correctly referring to "[2.5.5 Cable connection on the MA Board and error symptoms \(p53\)](#)".

3.5.9 The service tools and the adjustment tasks list which required before and after parts replacement

The following table describes the service tools and adjustment tasks which required before and after parts replacement. Please refer to "The service tool list" about their basic operation manuals.

	<p>** : Require for applied model only.</p> <p>*1 : Instruction: Write the current firmware immediately after MA Board is replaced.</p> <p>*2 : Instruction: Write the DR data to MA Board before calibration.</p> <p>Gray out: Non-applied for this model.</p>
---	---

Replaced part name	Power on was possible/ impossible	Before/after replacement	Required adjustment tasks (service tools name)	Reference for the tasks
Optical Engine and MA Board set	Possible	Before	Read out the lamp operation time from the old MA Board. (IPS Tool)	" 3.5.10 Service tool list (p150)"
		After	*1 Write the current firmware by "USB for Updater" or "EasyMP Network for Updater" or (IPS Tool/IDOL).	" 3.5.10 Service tool list (p150)"
			Set the destination. (RESCUE)	" 3.5.10 Service tool list (p150)"
			Calibrate G-sensor.**	" 3.7 G Sensor Calibration (p161)"
			Calibrate on for (Screen Fit/Frame Fit/Easy setup)**	Non-applied for this model.
			Set the commander and receiver for stack 3D display.**	Non-applied for this model.
			Set the "local time".**	" 3.3.9 RTC Board (p97)"
			Write the lamp operation time to the new MA Board. (IPS Tool)	" 3.5.10 Service tool list (p150)"
Optical Engine and MA Board set	Impossible	After	*1 Write the current firmware by "USB for Updater" or "EasyMP Network for Updater" or (IPS Tool/IDOL).	" 3.5.10 Service tool list (p150)"
			Set the destination. (RESCUE)	" 3.5.10 Service tool list (p150)"
			Calibrate G-sensor.**	" 3.7 G Sensor Calibration (p161)"
			Calibrate on for (Screen Fit/Frame Fit/Easy setup)**	Non-applied for this model.
			Set the commander and receiver for stack 3D display.**	Non-applied for this model.
			Set the "local time".**	" 3.3.9 RTC Board (p97)"

Replaced part name	Power on was possible/impossible	Before/after replacement	Required adjustment tasks (service tools name)	Reference for the tasks
MA Board	Possible	Before	Read out the lamp operation time from the old MA Board. (IPS Tool)	" 3.5.10 Service tool list (p150)"
			Back up the DR data of Optical Engine from the old MA Board. (CAT)	" 3.6 Writing the DR Data (p152)"
		After	*1 Write the current firmware by "USB for Updater" or "EasyMP Network for Updater" or (IPS Tool/IDOL).	" 3.5.10 Service tool list (p150)"
			Set the destination. (RESCUE)	" 3.5.10 Service tool list (p150)"
			Write the DR data of Optical Engine to the new MA Board. (CAT)	" 3.6 Writing the DR Data (p152)"
			Calibrate G-sensor.**	" 3.7 G Sensor Calibration (p161)"
			*2: Calibrate on for (Screen Fit/Frame Fit/Easy setup).**	Non-applied for this model.
			Set the commander and receiver for stack 3D display.**	Non-applied for this model.
			Set the "local time".**	" 3.3.9 RTC Board (p97)"
			Write the lamp operation time to the new MA Board. (IPS Tool)	" 3.5.10 Service tool list (p150)"
			Perform the Panel Alignment. **	" 3.8 LCD Alignment (p162)"
MA Board	Impossible	Before	Take the DR data from the "Intramart" data base. (Intramart)	" 3.5.10 Service tool list (p150)"
		After	*1 Write the current firmware by "USB for Updater" or "EasyMP Network for Updater" or (IPS Tool/IDOL).	" 3.5.10 Service tool list (p150)"
			Set the destination. (RESCUE)	" 3.5.10 Service tool list (p150)"
			Write the DR data of Optical Engine to the new MA Board. (CAT)	" 3.6 Writing the DR Data (p152)"
			Calibrate G-sensor.**	" 3.7 G Sensor Calibration (p161)"
			*2: Calibrate on for (Screen Fit/Frame Fit/Easy setup).**	Non-applied for this model.
			Set the commander and receiver for stack 3D display.**	Non-applied for this model.
			Set the "local time".**	" 3.3.9 RTC Board (p97)"
			Perform the Panel Alignment. **	" 3.8 LCD Alignment (p162)"

Replaced part name	Power on was possible/impossible	Before/after replacement	Required adjustment tasks (service tools name)	Reference for the tasks
Optical engine	---	---	Take the DR data from the "Intramart" data base. (Intramart)	" 3.5.10 Service tool list (p150)"
			Write the DR data of Optical Engine to the MA Board. (CAT)	" 3.6 Writing the DR Data (p152)"
			*2: Calibrate on for (Screen Fit/Frame Fit/Easy setup).**	Non-applied for this model.
			Perform the Panel Alignment. **	" 3.8 LCD Alignment (p162)"
Lamp	---	---	Initialize the Lamp information. (AS menu)	" 4.1.3 Initializing (Resetting) (p190)"

3.5.10 Service tool list

The following table describes the link of the basic operation manuals and the function about the service tools at [3.5.9 The service tools and the adjustment tasks list which required before and after parts replacement \(p148\)](#).

Tool Name		Necessary to update	Function	Basic operation manuals		
				TI-No	Reference	File name
IPS Tool	Referring to the projector information.		Obtaining the AS menu information.	AP14-0916-01	Tech Exchange TI (Utility/Tool)	IPS-Tool_Manual(E).xlsx
	Writing the projector IPS-Tool_Manual (E).xlsx information.		Reading out the lamp operation time from the MA Board. Writing the lamp operation time to the MA Board.			
	Updating firmware.		Writing the firmware to the LCP.			
CAT		o	Reading the DR data from the old MA Board of a failed LCP and save them as file on PC. Writing the DR-data from PC to the new MA Board of the LCP.	AP08-0912E	Tech Exchange TI (Utility/Tool)	SERVICE_TOOL_MANUAL_E_*.pdf
Intra-mart			Delivery system for the DR data.	AP08-0912E	Tech Exchange TI (Utility/Tool)	
RESCUE		o	Set the destination.	RE001	Tech Exchange TI (Utility/Tool)	
USB firmware for updater			Writing the firmware to the LCP by USB or USB cable.		Tech Exchange TI (General)	Firmware Ver.** (bin file) release for USB Updater
Easy MP Network firmware for updater Firmware			Updating the firmware of the LCP by wire network.		Tech Exchange TI (General)	Firmware Ver.** (bin file) release for EasyMP Network Update

Preparation Tools to operate the service tools

Tool Name	Necessary to update	Function	Basic operation manuals		
			TI-No	Reference	File name
USB COM Driver	-	This driver enables the connection between the USB cable and PC. It is required for operating the IPS Tool/CAT/RESCURE.	DR09-0602-01	Tech Exchange TI(Driver)	New VCOM2 Driver
Microsoft .Net Framework 3.5 or later	-	This environment is required for operating the IPS Tool.	-	-	-

3.6 Writing the DR Data

3.6.1 Overview

In this case (a new combination of them), you will write the DR data adjusted for the characteristics of the Optical Engine (current or replaced) into the newly-combined MA Board according to the specified procedure. This section describes the specific repair process including how to write the DR data.

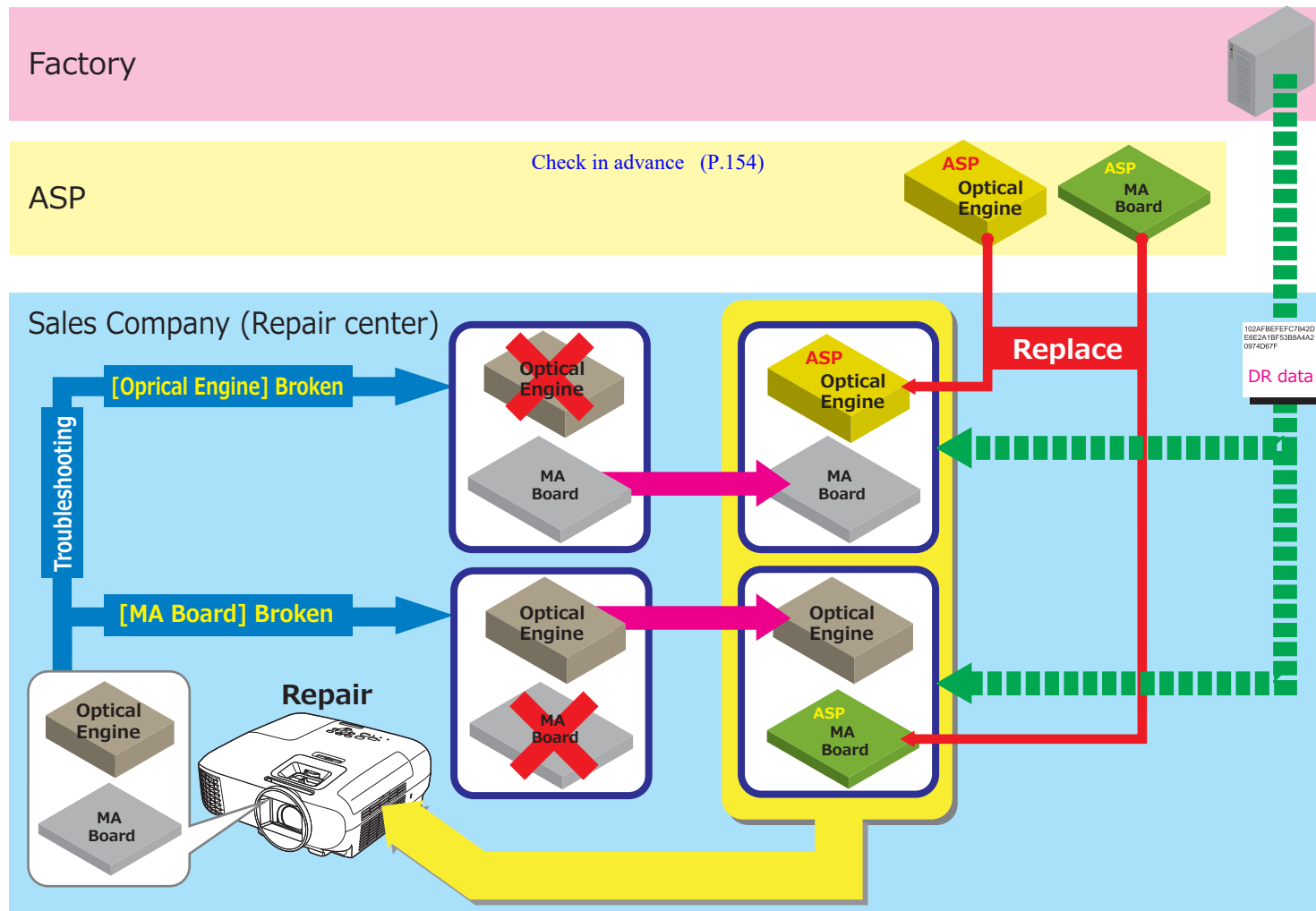

Conceptual diagram of the replacement using DR data

3.6.2 Preparation

Obtain the following tools from the Tech Exchange in advance.

Tool Name	Remark
CAT (IRIS/CAT)* ¹	Install it in your PC.
"IRIS_MENT.zip" file* ²	Save this file to the specified folder.
Model Group List* ²	Necessary for selecting the current model on the CAT, and also for preparing the correct ASP for the projector to be repaired.

Note *1:(Definition file)

*2:Use the latest ones referring to "TI18-25E".

3.6.3 Operating Procedure

3.6.3.1 Workflow

The whole replacing operation work flow is shown below.

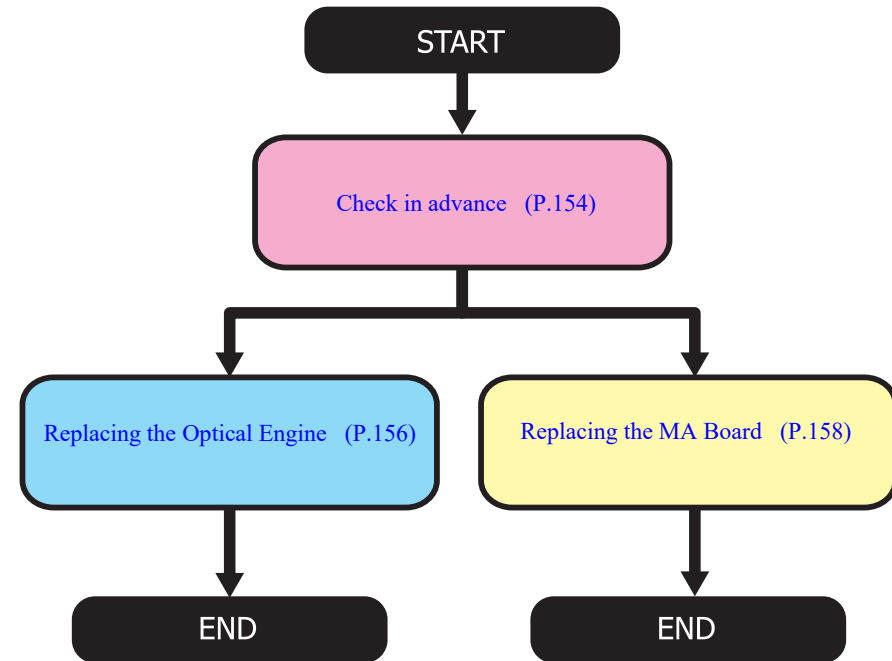

Workflow for the replacement using DR data



In the following procedure, refer to the "CAT Operation Manual" published as the technical information "AP08-0912E" for more detailed operation procedures of CAT.

3.6.3.2 Check in advance

This check inspects the Optical Engine and the MA Board to specify the current trouble is occurring either in the Optical Engine or in the MA Board.

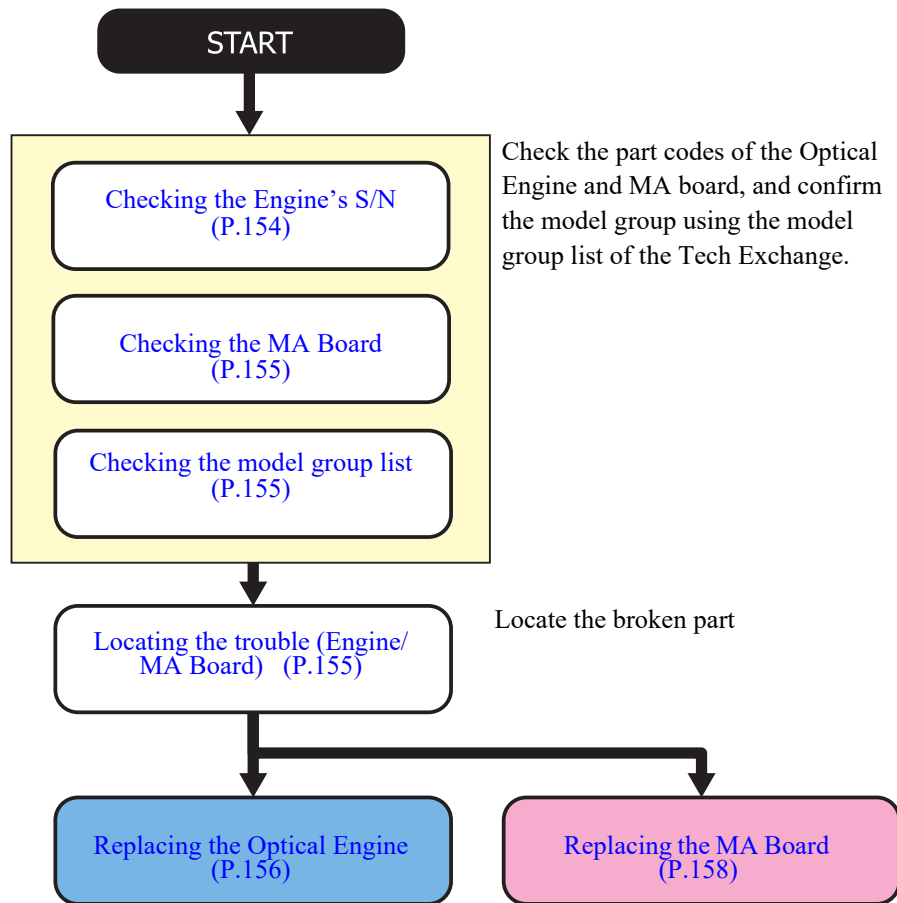

Flow for the check in advance

PROCEDURE FOR CHECK IN ADVANCE

1. Checking the Engine's S/N

Write down the serial number (11digits) on the label attached on the Optical Engine.

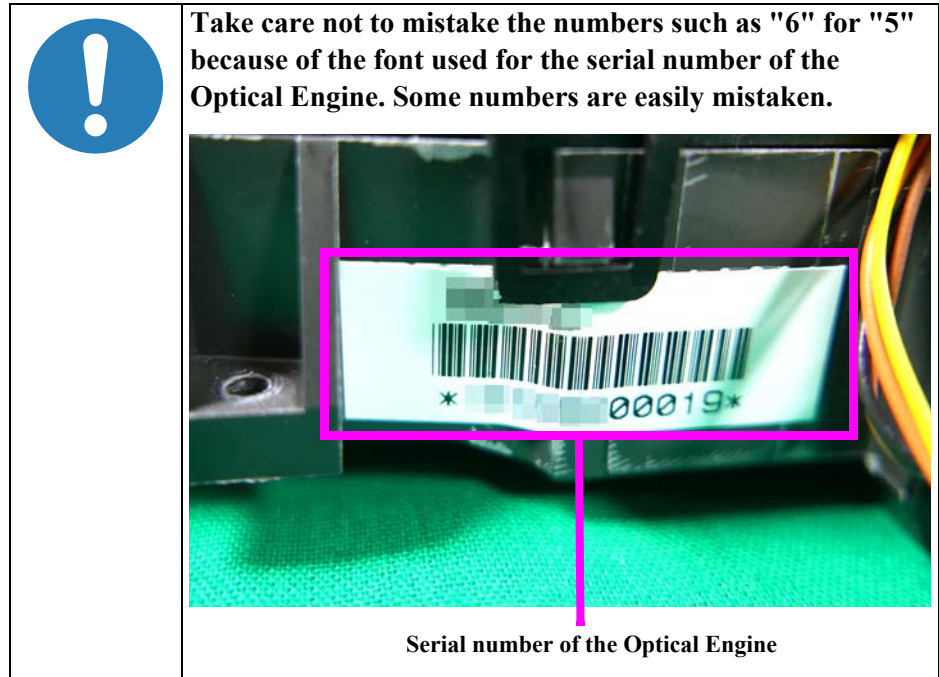

(Continued on the next page)

2. Checking the MA Board

Check the following on the MA Board.

- Check the label attached on the MA Board for the current model.
- Confirm the check marks in the marking box.

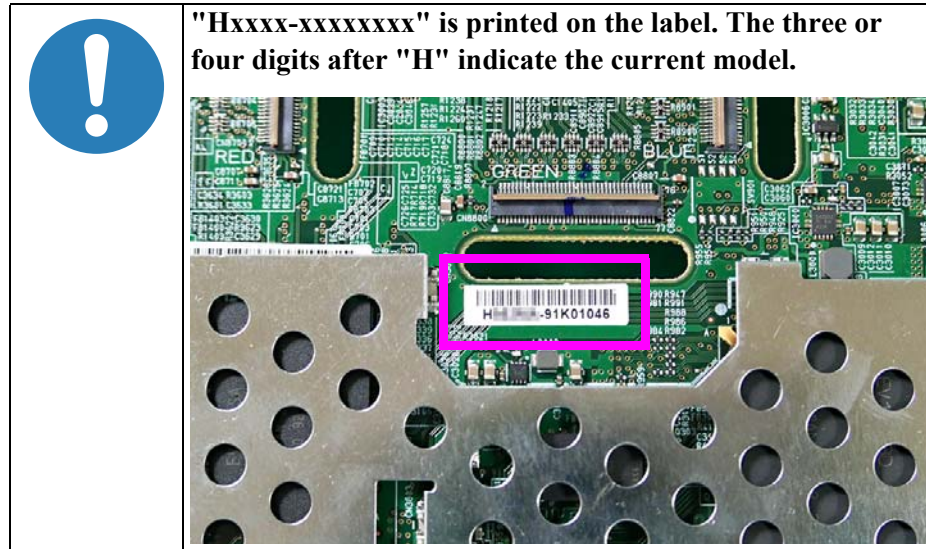

4. Locating the trouble (Engine/MA Board)

Prepare both a good engine and an MA board, and check either of the engine or the MA board has trouble by changing it with the good one.

3. Checking the model group list

Refer to the Technical Information "AP08-0912E" and obtain the latest model group list, then check which group the current MA Board belongs to.

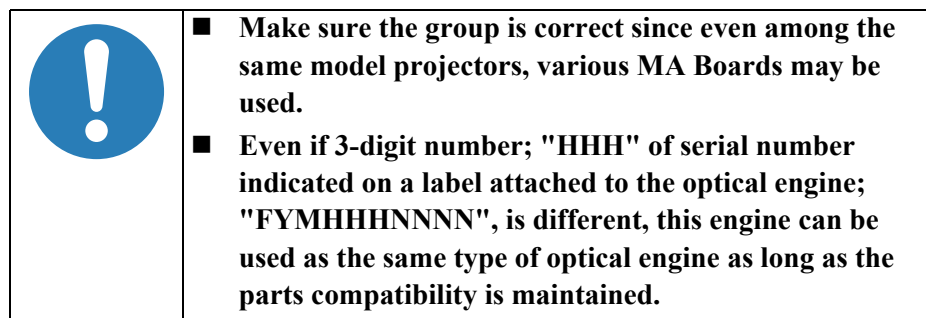

3.6.3.3 Replacing the Optical Engine

This section describes how to repair when the optical engine is broken.

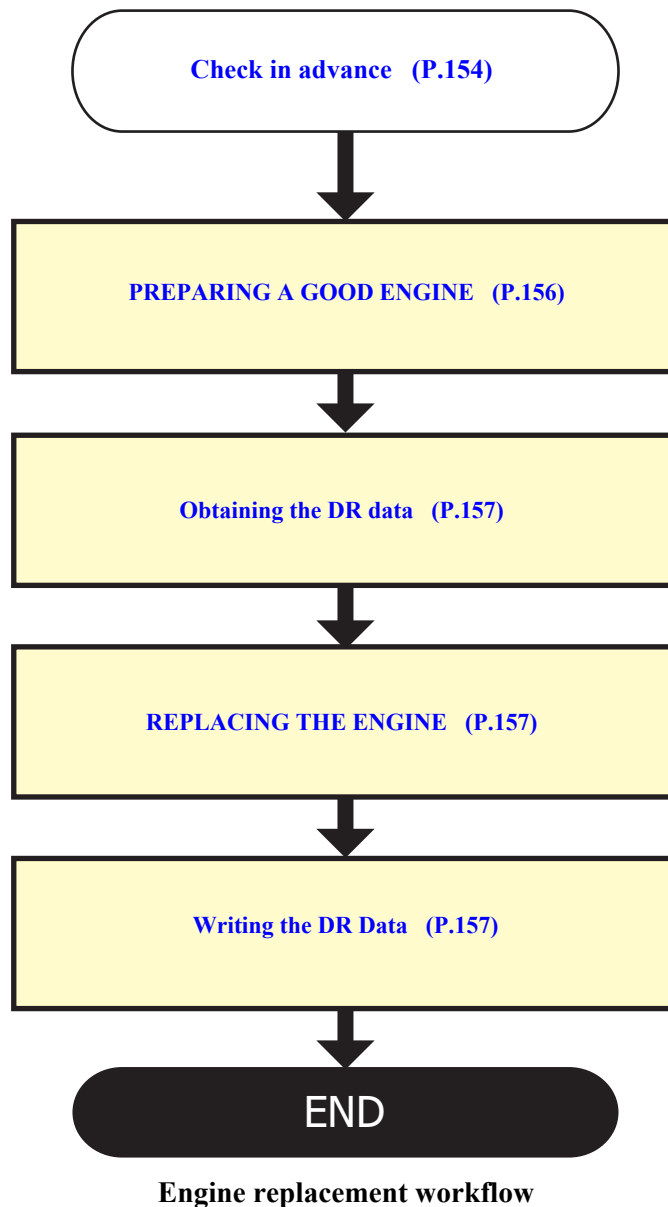

PREPARING A GOOD ENGINE

1. Preparing a good engine for replacement
 - Prepare a good Optical Engine belonging to the same model group as the current MA Board for replacement.
 - Write down the serial number (11 digits) on the label attached on the Optical Engine.

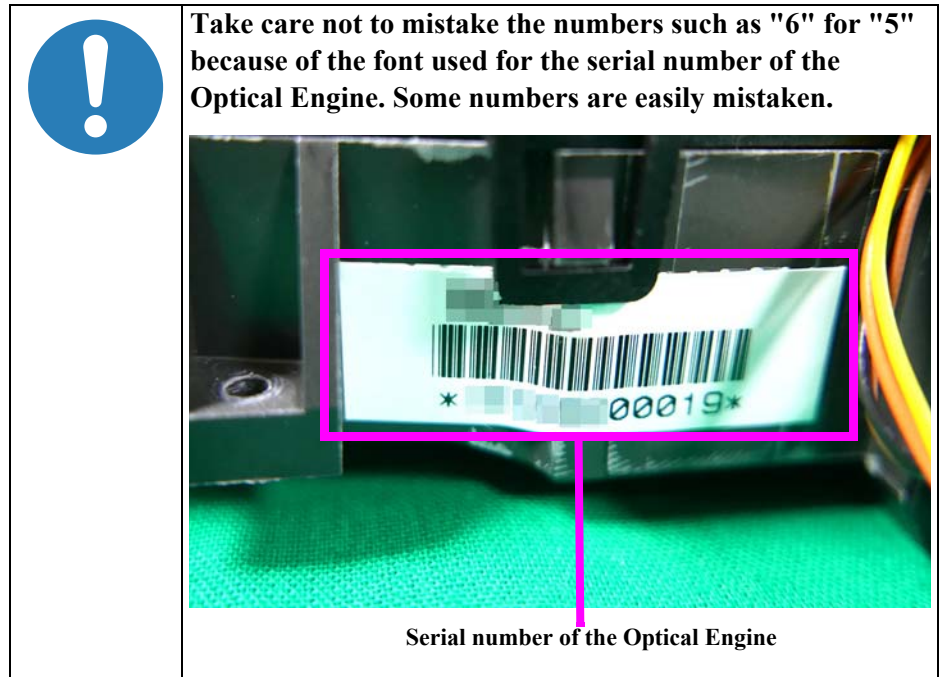

(Continued on the next page)

3.6.3.4 Replacing the MA Board

This section describes how to repair when the MA Board is broken but the projector can be powered on.

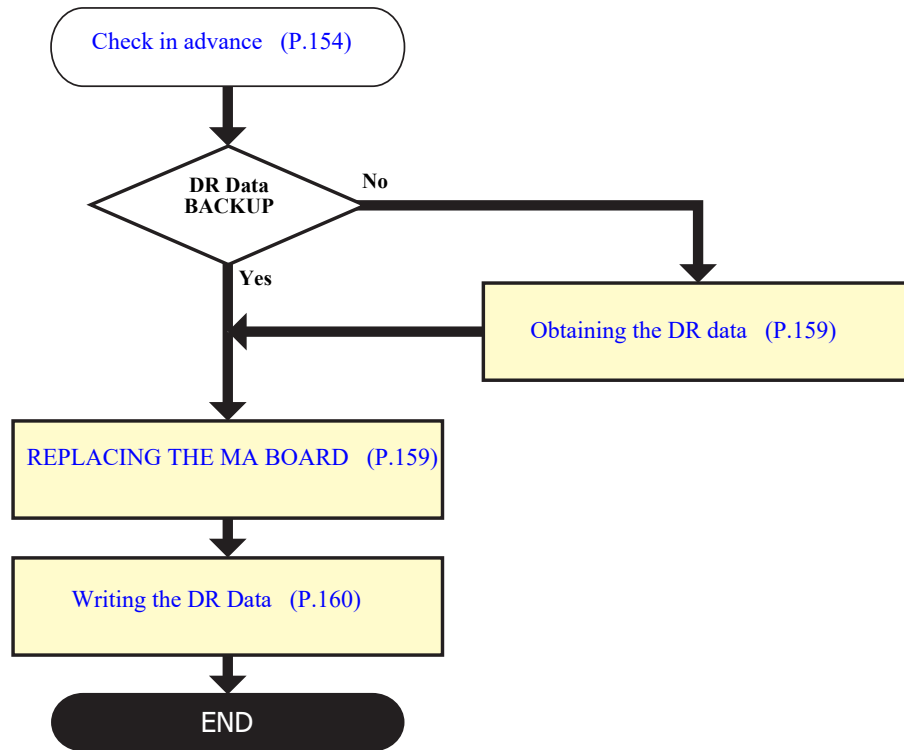

MA Board replacement workflow

BACKING UP THE DR DATA

1. Turning on the projector and Connecting to the PC
 - Connecting using RS-232C cable
 1. Press the [Power] button on the projector or the remote controller to turn on the projector.
 2. Connect the projector to the PC using RS-232C cable.



See "User's Guide" for the method to configure serial communication.

- Connecting using USB cable
 1. Disconnect the power cord from the projector and check that all of the indicators on the projector are off.
 2. Connect the power cord to the projector while pressing the [Enter] button on the Control Panel or remote controller. When the LED panel on the projector flashes four times and then lights up, release the [Enter] button.
 3. Connect the projector to the PC using USB cable.

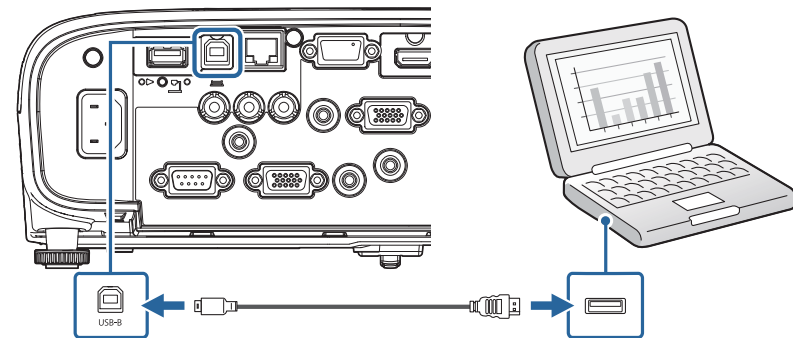

4. Press the [Power] button on the projector or the remote controller.

2. Backing up the DR data

- 2-1. Start up the CAT.
- 2-2. Select [SETUP]-[SELECT MODEL], and choose the group matched with the model group list.
- 2-3. Run "BACKUP".



Even if the model number; Hxxx that indicated on a label attached to the MA board, is not matching to the model number indicated on the serial number label of the optical engine, you can still execute BACKUP operation by selecting the "group" in the Model Group List for [SELECT MODEL] menu.

BACKUP: SUCCEEDED

Go to "REPLACING THE MA BOARD".

BACKUP: FAILED

Obtaining the DR data

1. Obtaining the DR data

Obtain the corresponding DR data referring to the Technical Information AP08-0912E.

2. Saving the data to the PC

Save the DR data file to the following folder in the PC.

C:\IRIS\DRDATA



- **RESTORE** cannot operate correctly if the DR data is not saved in the specified folder. (RESTORE will not operate correctly if the file cannot be checked.)
- **Do not change the name of the DR data file.**

REPLACING THE MA BOARD

1. Replacing it with a good MA Board

Prepare a good MA Board belonging to the same model group, and replace the boards.

2. Turning on the projector and Connecting to the PC

- Connecting using RS-232C cable

1. Press the [Power] button on the projector or the remote controller to turn on the projector.
2. Connect the projector to the PC using RS-232C cable.



See "User's Guide" for the method to configure serial communication.

- Connecting using USB cable

1. Disconnect the power cord from the projector and check that all of the indicators on the projector are off.
2. Connect the power cord to the projector while pressing the [Enter] button on the Control Panel or remote controller. When the LED panel on the projector flashes four times and then lights up, release the [Enter] button.
3. Connect the projector to the PC using USB cable.

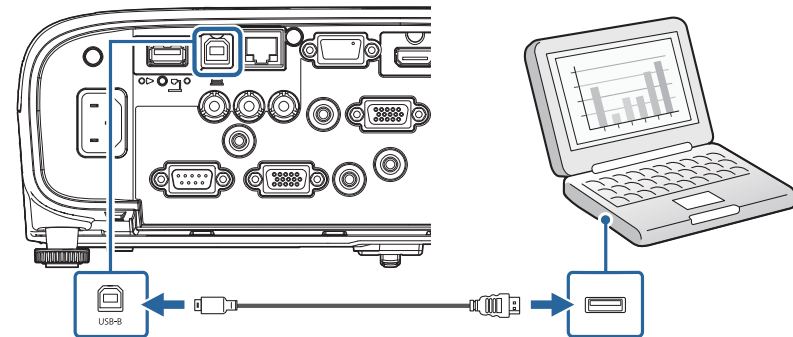

4. Press the [Power] button on the projector or the remote controller.

WRITING THE DR DATA

3. Writing the DR Data

- 3-1. Start up the CAT.
- 3-2. Select the group from SETUP / SELECT MODEL menu, by referring to the number; ******* and **xx**, that can be found in a file name; "**H***_xx_yyy_zzzzz_zzzzzz_zzzzzz.bin**" of supplied DR data.
- 3-3. Enter the 11-digit serial number of the engine noted in advance, and run "RESTORE".



The DR data is not stored on a brand-new MA board, and due to this, "\$\$\$\$\$\$\$" appear on the menu screen when trying to restore the DR data, but a restore operation itself can be completed normally.

4. Image/Operation check

Restart the projector (Power OFF → Power ON) once, and confirm there is no problem in the projected image and operation.

3.7 G Sensor Calibration

3.7.1 Overview

The G Sensor is mounted on the MA Board to detect the inclination of the projector. To compensate the variation of the accuracy of the G Sensor detection among the products, perform this calibration after replacing and/or reassembling any parts which require the replacement of the MA board at the same time.

(Not compatible with EB-E01/E10/E20, EH-TW740)

3.7.2 Preparation

1. Be sure that all feet of the projector for which you perform this calibration are completely retracted.
2. Place the projector on an even and stable place such as on the top of a table.

3.7.3 Procedure

1. Connect the power cable and then press the [Power] button.
2. Check if the Power LED flashes blue, then lights blue.
3. After the LED lights up, long-press the [Home] button and the [Source Search] button together for five seconds or more.

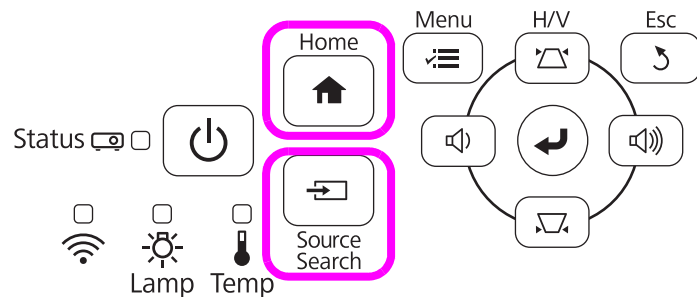

4. When the buzzer sounds, calibration is completed.
5. Confirm that the keystone function does not work when all feet are retracted. (menu value: 0)

3.8 LCD Alignment

3.8.1 Overview

This projector is equipped with a function to adjust the color shift of the pixels of the LCD panel.

□ Compatible models: EB-FH06/FH52/EB-992F, EH-TW740/TW750

Color shift can be adjusted within a range of ± 1.0 pixels in increments of 1.0 pixels in horizontal and vertical directions.

Only the entire screen can be adjusted. Individual parts of the screen cannot be adjusted.

This section explains the specific method of LCD alignment.

3.8.2 Pixel color shift confirmation method



If the MA Board and the Optical Engine Assy is replaced, check for color shift of pixels after replacement, and if color shift is identified, use this function to adjust it.

1. Disconnect the power cord from the projector and check that all of the indicators on the projector are off.
2. Put power cord in the body while pressing [Enter] button. When the indicator on the projector flashes five times and then lights up, release the [Enter] button.
3. Press the [Power] button to turn on the projector.
4. Press and hold the [Esc] button for three seconds or more.

5. When the internal patterns are displayed, display the pattern for checking the pixel color shift using the [Left] and [Right] buttons.



Pattern for checking the pixel color shift

6. Check the color shift of the pixels for the entire screen.
7. If color shift is detected, adjust it as shown below.

3.8.3 LCD alignment activation method



- **This function is exclusive to the after service, as is not open to end users.**
- **When starting up, use the software DIP-SW to display the menu, and use it again to close the menu after adjustment.**

Start the LCD alignment using the operation panel (or the remote controller) according to the procedure below.

1. Press and hold the [Menu] button for five seconds or more.
2. Release the [Menu] button, and within four seconds press the [Esc] button twice consecutively.

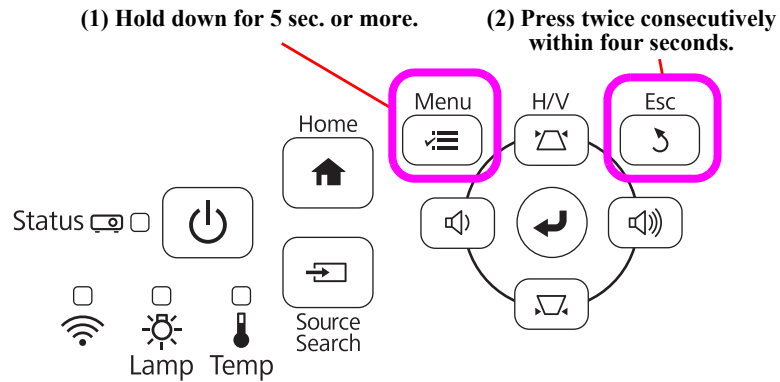

3. AS menu will be displayed.
4. Repeat the steps 1 and 2 while the AS menu is displayed.
5. The software DIP-SW is displayed. (Not displayed at the time of communication command)

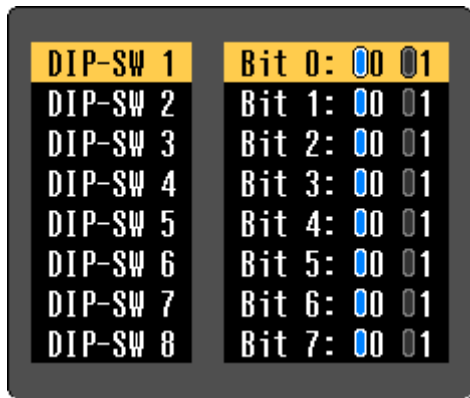

6. Select the DIP-SW 6 and then press the [Enter] button.
7. Select Bit 5, and switch between 0 and 1 using the [Left] and [Right] buttons.
8. Close the software DIP-SW by pressing the [Menu] button.

9. Restart the projector to reflect the changes in settings.
10. After restarting the projector, press the [Menu] button.
11. Select [Enlargement Settings] and then press the [Enter] button.
12. Select [Display Settings] and then press the [Enter] button.
13. Select [LCD Alignment] and then press the [Enter] button.

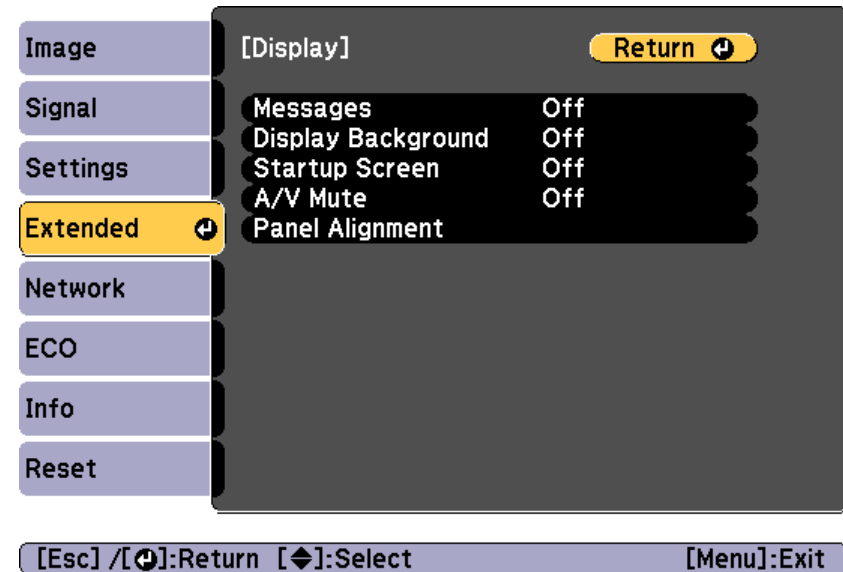

3.8.3.1 Adjustment method

1. Enable [LCD Alignment].

1-1. Select [LCD Alignment] and then press the [Enter] button.

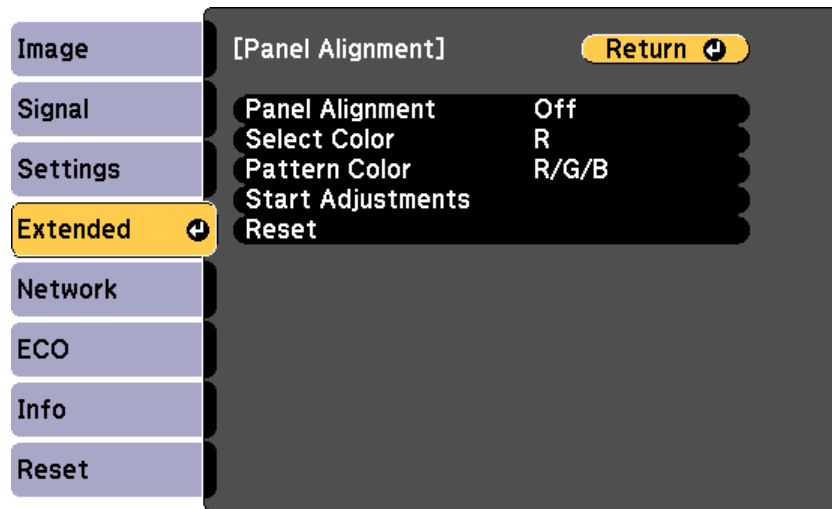

[Esc] / [Enter]:Return [Enter]:Select [Menu]:Exit

1-2. Select [ON] and then press the [Enter] button.

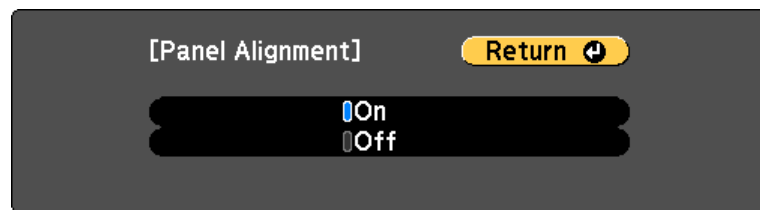

[Esc] / [Enter]:Return [Enter]:Select [Menu]:Exit

1-3. Press the [Esc] button to return to the previous screen.

2. Select the color you want to adjust.

2-1. Select [Adjustment Color] and then press the [Enter] button.

2-2. Select either [R] (Red) or [B] (Blue) and then press the [Enter] button.

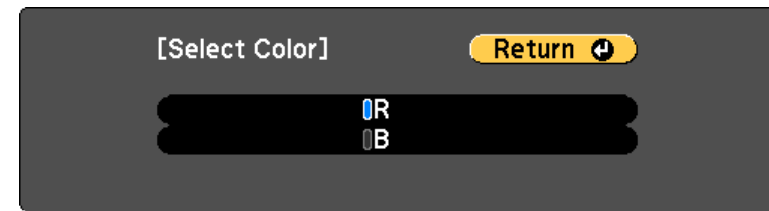

[Esc] / [Enter]:Return [Enter]:Select [Menu]:Exit

2-3. Press the [Esc] button to return to the previous screen.

3. In [Pattern Color], select the color of the grid displayed at the time of adjustment.

3-1. Select [Pattern Color] and then press the [Enter] button.

3-2. Select a combination of R (Red), G (Green) and B (Blue) for the grid color.

[R/G/B]: Three-color display with R, G, B. The color of the actual grid is white.

[R/G]: Can be selected when [R] is selected as the [Adjustment Color]. Two-color display with R, G. The color of the actual grid is yellow.

[G/B]: Can be selected when [B] is selected as the [Adjustment Color]. Two-color display with G, B. The color of the actual grid is cyan.

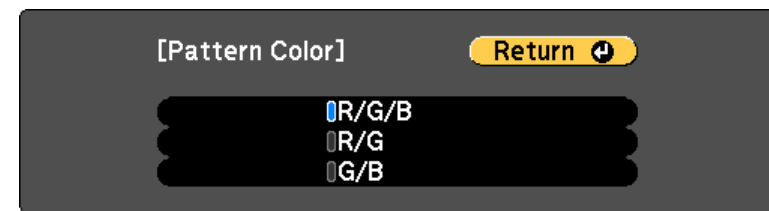

[Esc] / [Enter]:Return [Enter]:Select [Menu]:Exit

3-3. Press the [Esc] button to return to the previous screen.

4. Select [Start Adjustment] and then press the [Enter] button.
5. Adjust using the [Up], [Down], [Left], and [Right] buttons, and press the [Esc] button when the adjustment is complete.
(Adjustment Guide is displayed at the bottom right of the screen during adjustment)

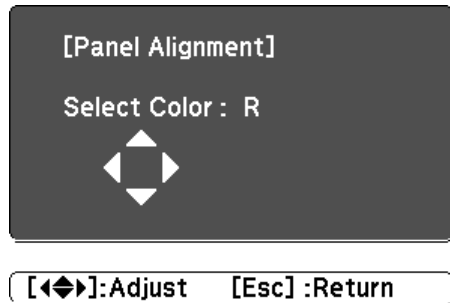

The color of the \triangle symbols in the four direction have the following meanings.



:The state of being in the initial position (position when this function is started)



:The state when the point of adjustment has moved to the end of the range, and no further movement is possible in that direction.

6. Press the [Menu] button to complete the LCD Alignment.
7. According to [3.8.3 LCD alignment activation method \(p162\)](#), switch between 1 and 0 for Bit 5 of DIP-SW 6.
8. Close the software DIP-SW by pressing the [Menu] button.
9. Restart the projector to reflect the changes in settings.
10. After restarting the projector, press the [Menu] button.
11. Select [Enlargement Settings] and then press the [Enter] button.
12. Select [Display Settings] and then press the [Enter] button.

13. Check that [LCD Alignment] is not displayed on the Display Settings screen.

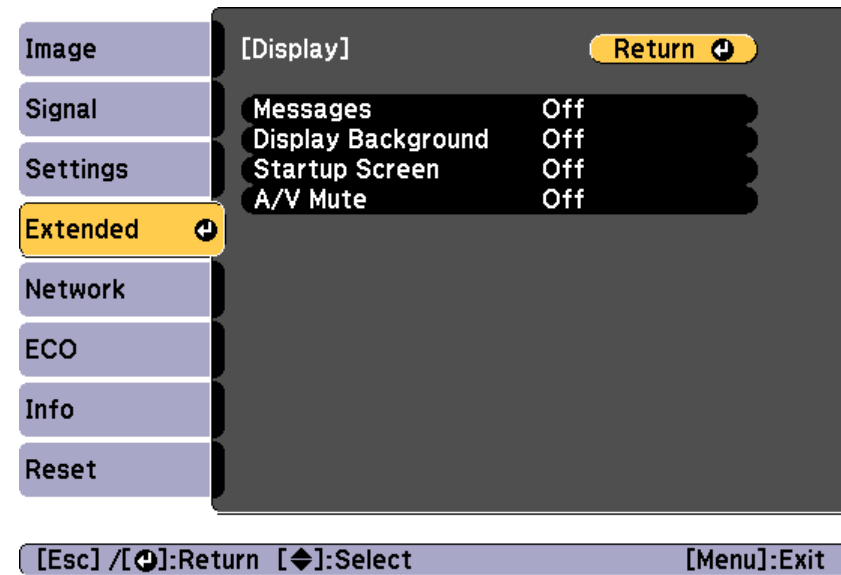

3.9 Part Names List

Part names are written as abbreviations in this manual. Below is the correspondence table of the abbreviations and SPI notation of the part names.

PART NAMES LIST

Name used in this manual	SPI Parts Name
Optical Engine Assy	OPT ENGINE ASSY-X;H971;PH;AS
	OPT ENGINE ASSY-X;H972;PH;AS
	OPT ENGINE ASSY-X;H975;PH;AS
	OPT ENGINE ASSY-X;H976;PH;AS
	OPT ENGINE ASSY-X;H981;PH;AS
	OPT ENGINE ASSY-X;H982;PH;AS
	OPT ENGINE ASSY-X;HA03;PH;AS
	OPT ENGINE ASSY-X;H986;PH;AS
	OPT ENGINE ASSY-WX;H973;PH;AS
	OPT ENGINE ASSY-WX;H983;PH;AS
	OPT ENGINE ASSY-WX;H987;PH;AS
	OPT ENGINE ASSY-FH;H974;PH;AS
	OPT ENGINE ASSY-FH;H978;PH;AS
	OPT ENGINE ASSY-FH;H979;PH;AS
	OPT ENGINE ASSY-FH;H980;PH;AS
Lamp Assy	LAMP ASSY;H950;AS
Lower Case	CASE UNIT,LOWER;K1-WH;PH
	CASE UNIT,LOWER;K1-BK;PH
	CASE UNIT,LOWER;D1-WH;PH
	CASE UNIT,LOWER;D1-BK;PH
RC Filter	FILTER,RC
Front Foot	FOOT UNIT,FRONT
Rear Foot	FOOT,REAR,AS_CKD
Lower Shield Plate A	SHIELD PLATE,LOWER;A;PH
Lower Shield Plate B	SHIELD PLATE,LOWER;B;PH
FB Insulation Sheet	SHEET,INSULATION,FB;H838;PH
Filter Board	FILTER BOARD UNIT;H838;PI;2

Name used in this manual	SPI Parts Name
Inlet Cable	CABLE,INLET-H838;PH
IR Board	PCB ASSY;H980IR-MP;PH
RCF Cable	CABLE,RC FRONT-H850;PH;2
PS Holder	HOLDER,PS
Lower Cushion Seal	CUSHION,SEAL,LOWER;H850;PH
Lower Cushion	CUSHION,LOWER;H850;PH
Inlet Fasten Plate	PLATE,FASTEN,INLET;KH;PH
	PLATE,FASTEN,INLET;V16H;PH
INT Duct A	DUCT,INTAKE;A;K;PH
	DUCT,INTAKE;A;D;PH
INT Duct B	DUCT,INTAKE;B;K;2;PH
	DUCT,INTAKE;B;H978;PH
	DUCT,INTAKE;B;H980;PH
INT Fan	FAN;SR7039-THT-H838
Cable Fasten Tape	TAPE,CABLE FASTEN;PH
INT Duct Cushion Seal C	CUSHION,SEAL,DUCT INTAKE;C-H850;PH
INT Duct Cushion Seal D	CUSHION,SEAL,DUCT INTAKE;D-H850;PH
TH Board	PCB ASSY;H980TH-MP;PH
TH Cable H550	CABLE,TH-H550;PH;2
TH Cable H309	CABLE,TH-H309;PH;2
P4combo Module	P4combo module;MP
FFC 15P	FFC,SHIELD,15-H978
Lower Conduction Plate	PLATE,CONDUCTION,LOWER;K;2;PH
	PLATE,CONDUCTION,LOWER;V;PH
Conduction Cushion	CUSHION,CONDUCTION;PH
PS Ballast Assy	PS BALLAST UNIT ASSY;H838;EP;PH2;5
Cable PS-MA	CABLE,PS-MA-H838-B;PH;2
Cable PS-FB	CABLE,PS-FB-H838;PH
Cable BA-Lamp	CABLE,BA-LAMP-H838
PS Shield Plate	SHILED PLATE,PS;A;PH
	SHIELD PLATE,PS;B;PH

Name used in this manual	SPI Parts Name
Fasten Nut Plate	PLATE,FASTEN,NUT;A;PH
	PLATE,FASTEN,NUT;B;PH
Lower Sheet	SHEET,LOWER;A;PH
Lamp Fan	FAN,LAMP
Lamp Fan Cushion A	CUSHION,LAMP FAN;A-H971;PH
Lamp Fan Cushion B	CUSHION,LAMP FAN;B-H971;PH
Lamp Connector Holder	HOLDER,CONNECTOR,LAMP;K;PH
	HOLDER,CONNECTOR,LAMP;D;PH
Speaker 5W	SPEAKER;5W-MT-H838
	SPEAKER;5W-LY-H854
GND Cable	CABLE, GND;2
Lower EX Duct	DUCT,EXHAUST,LOWER;PH
EX Plate	PLATE,EXHAUST;PH
EX Fan	FAN;TB6035-NMB-H838
EX Fan Cushion A	CUSHION,EX FAN;A-H971;PH
EX Fan Cushion B	CUSHION,EX FAN;B-H971;PH
Upper EX Duct	DUCT,EXHAUST,UPPER;PH
TH Cable H838	CABLE,TH-H838;PH;2
Auto Iris Assy	AUTO IRIS ASSY;H838;PH;AS
Focus Ring	FOCUS RING;PH
	FOCUS RING
	FOCUS RING.
	RING,FOCUS;H971;PH
	FOCUS RING;C;PH
Zoom Ring	ZOOM RING
	ZOOM RING.
	ZOOM RING;C;PH
RTC Board	PCB ASSY;H980RTC-MP;PH
RTC Cable H854	CABLE,RTC-H854;PH
RTC Cable H980	CABLE,RTC-H980;PH
Lithium Battery	LITHIUM BATTERY

Name used in this manual	SPI Parts Name
MA Board Assy	MA BOARD ASSY;H971;PH;AS
	MA BOARD ASSY;H972;PH;AS
	MA BOARD ASSY;H975;PH;AS
	MA BOARD ASSY;H976;PH;AS
	MA BOARD ASSY;H981;PH;AS
	MA BOARD ASSY;H982;PH;AS
	MA BOARD ASSY;HA03;PH;AS
	MA BOARD ASSY;H986;PH;AS
	MA BOARD ASSY;H973;PH;AS
	MA BOARD ASSY;H977;PH;AS
	MA BOARD ASSY;HA02;PH;AS
	MA BOARD ASSY;H983;PH;AS
	MA BOARD ASSY;H985;PH;AS
	MA BOARD ASSY;H987;PH;AS
	MA BOARD ASSY;H974;PH;AS
MA BOARD ASSY;H978;PH;AS	
IF Board	MA BOARD ASSY;H988;PH;AS
	MA BOARD ASSY;H979;PH;AS
	MA BOARD ASSY;H980;PH;AS
	PCB ASSY;H981IF-MP;PH
	PCB ASSY;H982IF-MP;PH
	PCB ASSY;HA03IF-MP;PH
	PCB ASSY;H974IF-MP;PH
	PCB ASSY;H978IF-MP;PH
PCB ASSY;H979IF-MP;PH	
PCB ASSY;H980IF-MP;PH	
Conduction Plate 3RCA	PLATE,CONDUCTION,3RCA;KH;PH
Speaker 16W	SPEAKER;16W-MT-H978
MA Frame	FRAME,MA;H980;PH
Fasten Plate MA-PS	PLATE,FASTEN,MA-PS;PH
IF Shade Cover	COVER,SHADE,IF;V;PH
WFD Board	WFD BOARD ASSY;K;H846;PH;AS

Name used in this manual	SPI Parts Name
M-CUSHION H1W3L29	M-CUSHION,SHIELD;H1W3L29;PH
M-CUSHION H1W3L39	M-CUSHION,SHIELD;H1W3L39;PH
M-CUSHION H1W3L54	M-CUSHION,SHIELD;H1W3L54;PH
M-CUSHION H1W4L19	M-CUSHION,SHIELD;H1W4L19
M-CUSHION H1W10L17	M-CUSHION,SHIELD;H1W10L17;PH
WFD Shield Plate	SHIELD PLATE,WFD;K;PH
FFC 30P	FFC,SHIELD,30P-H838
FFC WFD-MA	FFC,WFD-MA;22;H824
FFC WFD-WRF	FFC,SHIELD,WFD-WRF;20;H814
WRF Holder	HOLDER,WRF;K;PH
P3dash Module	P3dash module
Upper Case	CASE,UPPER;H971-WH;PH
	CASE,UPPER;KB-WH-J;PH
	CASE,UPPER;KB-WH-E;PH
	CASE,UPPER;KAL-WH-E;PH
	CASE,UPPER;KAH-WH-E4;PH
	CASE,UPPER;KAH-WH-E3;PH
	CASE,UPPER;V-WH-E;PH
	CASE,UPPER;V-WH-J;PH
	CASE,UPPER;KAH-WH-E;PH
	CASE,UPPER;KAH-BK-E;PH
	CASE,UPPER;H978-WH-J;PH
	CASE,UPPER;H978-WH;PH
	CASE,UPPER;V-BK-E4;PH
	CASE,UPPER;V-WH-J1;PH
	CASE,UPPER;V-WH-E1;PH
CASE,UPPER;KAH-WH-E1;PH	
Upper Cushion A	CUSHION,UPPER;A
	CUSHION,PROLENS,A
Upper Cushion A-H722	CUSHION,UPPER;A-H722;PH

Name used in this manual	SPI Parts Name
Upper Cushion B	CUSHION,UPPER;B,PH
	CUSHION CASE UPPER;A
	CUSHION,UPPER;B,PH
Sheet Upper A	SHEET,UPPER;A-H850;PH
Sheet Lid Lamp	SHEET,LID LAMP;H850;PH
Sheet Upper H854	SHEET,UPPER;H854;PH
Upper Case	COVER,CASE UPPER;PH
	COVER,CASE UPPER;V;PH;2
Lid Lamp Switch	SWITCH,LID LAMP;PH;2
H Key Assy	H KEY ASSY;H972;PH;AS
LED Lens	LENS,LED;A;PH
SW Button	BUTTON,SW;H971;PH
	BUTTON,SW;a-WH;PH
	BUTTON,SW;a-BK;PH
Power Button	BUTTON,POWER;AW
	BUTTON,POWER;AB
SW Cable	CABLE,SW; Au;PH;2
SW Board	PCB ASSY;H971SW-MP;PH
	PCB ASSY;H981SW-MP;PH
	PCB ASSY;H972SW-MP;PH
	PCB ASSY;H980SW-MP;PH
Front Case	CASE UNIT,FRONT;H976;PH
	CASE,FRONT;KH1a-WH;PH
	CASE UNIT,FRONT;H974-WH;PH
	CASE UNIT,FRONT;H974-SV;PH
	CASE UNIT,FRONT;H978a;PH
	CASE UNIT,FRONT;H980;PH
Shutter frame	FRAME,SHUTTER;KL;PH
	FRAME,SHUTTER;KH;PH
	FRAME,SHUTTER;V;PH
	FRAME,SHUTTER;KH1;PH
Switch Cable H721-A	CABLE,SWITCH-H721-A;PH;2

Name used in this manual	SPI Parts Name
Shutter ball	BALL,SHUTTER
Shutter Spring	SPRING,SHUTTER
Lens Shutter	SHUTTER,LENS;KL-WH;PH
	SHUTTER,LENS;KL-BK;PH
	SHUTTER,LENS;KH-WH;PH
	SHUTTER,LENS;V;PH
	SHUTTER,LENS;KH-BK;PH
	SHUTTER,LENS;H978;PH
Shutter Lens Sheet	SHEET,SHUTTER LENS;KL-H838;PH
	SHEET,SHUTTER LENS;KH-H838;PH
EX Case	CASE,EX;KL-WH;PH
	CASE,EX;KL-BK;PH
	CASE,EX;KH-WH;PH
	CASE,EX;V-BK;PH
	CASE,EX;V;PH
	CASE,EX;KH-BK;PH
Upper Case Inner	COVER,UPPER,INNER;PH
Air Filter Cover Band	BAND,COVER,AIRFILTER
Air Filter Cover	LID,AIR FILTER;KL-WH;PH
	LID,AIR FILTER;KH-WH;PH
	LID,AIR FILTER;KH-BK;PH
	LID,AIR FILTER;V;PH
	LID,AIR FILTER;V-BK;PH

Name used in this manual	SPI Parts Name
Rear Case	CASE,REAR;H971-WH;PH
	CASE,REAR;KL-WH-J1;PH
	CASE,REAR;KL-WH-E1;PH
	CASE,REAR;H981-WH;PH
	CASE,REAR;V5-WH-EX;PH
	CASE,REAR;V5-WH-E1;PH
	CASE,REAR;V16L-WH-E3;PH
	CASE,REAR;V16H-WH-E2;PH
	CASE,REAR;HA02-WH;PH
	CASE,REAR;KH-WH-E4;PH
	CASE,REAR;KH-BK-E4;PH
	CASE,REAR;H978-WH-J;PH
	CASE,REAR;H978-WH;PH
	CASE,REAR;H978-BK;PH
	CASE,REAR;V16H-WH-E3;PH
CASE,REAR;H979-WH;PH	
CASE,REAR;H980-WH;PH	
RCR Filter	FILTER,RC;A
IF Label	LABEL,IF;H981-WH;PH
	LABEL,IF;H982-WH;PH
	LABEL,IF;H983-WH;PH
	LABEL,IF;H984-WH;PH
	LABEL,IF;H986-WH-J;PH
	LABEL,IF;H986-WH;PH
	LABEL,IF;H980-WH;PH
Lamp Cover	LID UNIT,LAMP;KL-WH;PH
	LID UNIT,LAMP;KH-WH;PH
	LID UNIT,LAMP;KH-BK;PH
	LID UNIT,LAMP;V;PH
	LID UNIT,LAMP;V-BK;PH
Air Filter Assy	AIR FILTER ASSY;AS
	AIR FILTER ASSY;DL;H850;PH;AS

CHAPTER

4

APPENDIX

4.1 AS (After Service) Menu



The contents of this chapter are only for use of Epson Authorized Services. Do not disclose them to the end-users.

The body operation Historical Information by which a record was preserved in the projector and the way to confirm the details of error Historical Information are explained by this item.

4.1.1 How To Display the AS (After Service) Menu

4.1.1.1 How to enter the AS menu

Start the AS menu with the operation panel (or the remote controller) using the procedure below.

1. Press and hold the [Menu] button for five seconds or more.
2. Release the [Menu] button, and within four seconds press the [Esc] button twice consecutively.

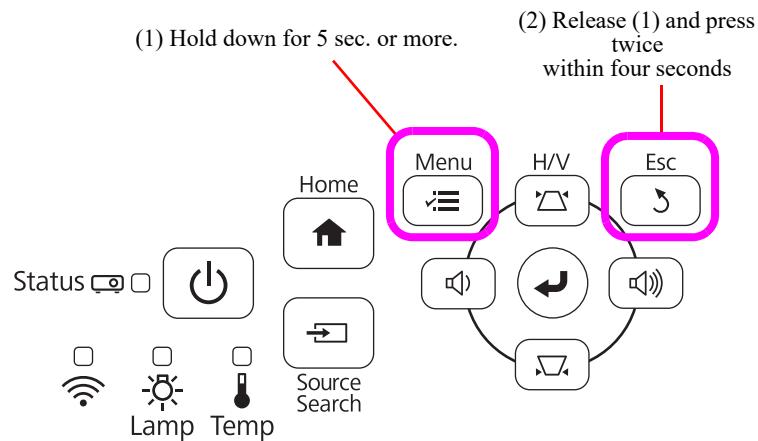

4.1.1.2 Menu Contents

The AS menu for this projector consists of eight pages. These pages can be switched by pressing the [Right]/[Left] button.

The contents/information displayed on each page are as follows.

Page	Description	
1st Page	Information relates to the visual data which is currently projected.	<input type="checkbox"/> Input source <input type="checkbox"/> Signal details
	Operation history of the lamp	<input type="checkbox"/> Total lamp operation time <input type="checkbox"/> Lamp replacement times, etc.
	Other product information	
2nd Page	Version information	<input type="checkbox"/> Firmware for the main unit <input type="checkbox"/> Firmware for subsystem
3rd Page	Time information (EB-FH52/992F, EH-TW750)	
4th Page	Error/Warning counts	
5th Page	Error/Warning details (Error Info)	
6th Page	Temperature log (Temp Info)	
7th Page	Operation Log (Operation Info)	
8th Page	Ballast error log	<input type="checkbox"/> Status when the error log is written. <input type="checkbox"/> Contents of the error log

Note: The contents displayed on the screen vary depending on the input source.

AS MENU: 1ST PAGE

The general operational history of the projector is displayed. The contents displayed on the screen vary depending on the input source.

□ PC/HDMI

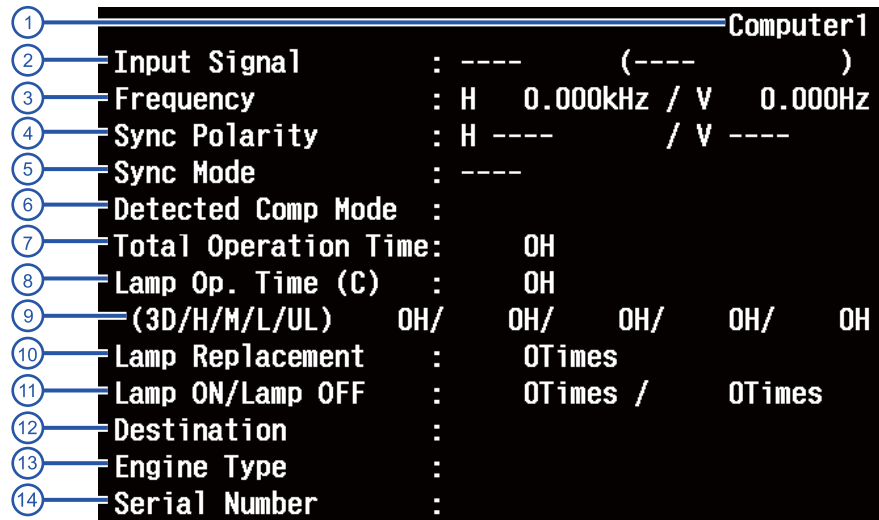

No.	Item
1	Current input source
2	Set value and detected value of the input signal
3	Horizontal/Vertical frequency
4	Horizontal/Vertical synchronization polarity
5	Synchronization mode
6	Detected computer mode
7	Total lamp operation time
8	Lamp operation time (converted into low brightness operation)
9	Lamp operation time of each brightness 3D: 3D image H: High-intensity mode M: Low noise mode L: Low-intensity mode UL: Ultra-low-intensity mode
10	Lamp replacement times
11	Lamp ON/OFF times
12	Destination
13	Type of optical engine
14	Serial number

□ VIDEO

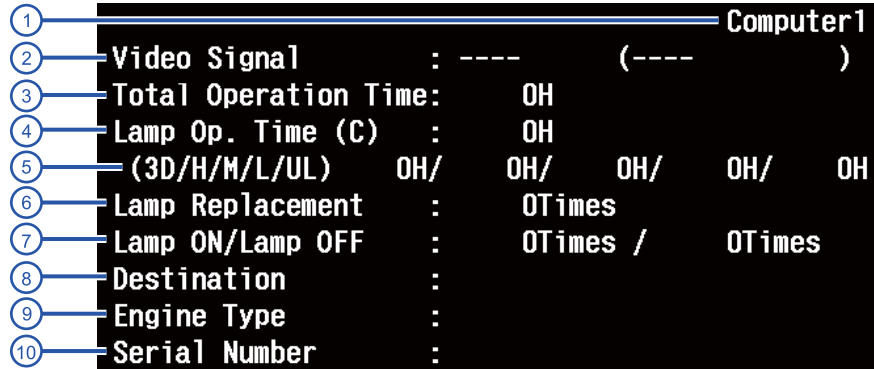

No.	Item
1	Current input source
2	Set value and detected value of the video signal
3	Total lamp operation time
4	Lamp operation time (converted into low brightness operation)
5	Lamp operation time of each brightness H : High-intensity mode L : Low-intensity mode 3D : 3D image M : Low noise mode UL : Ultra-low-intensity mode
6	Lamp replacement times
7	Lamp ON/OFF times
8	Destination
9	Type of optical engine
10	Serial number

AS MENU: 2ND PAGE

Firmware versions of this projector are displayed.

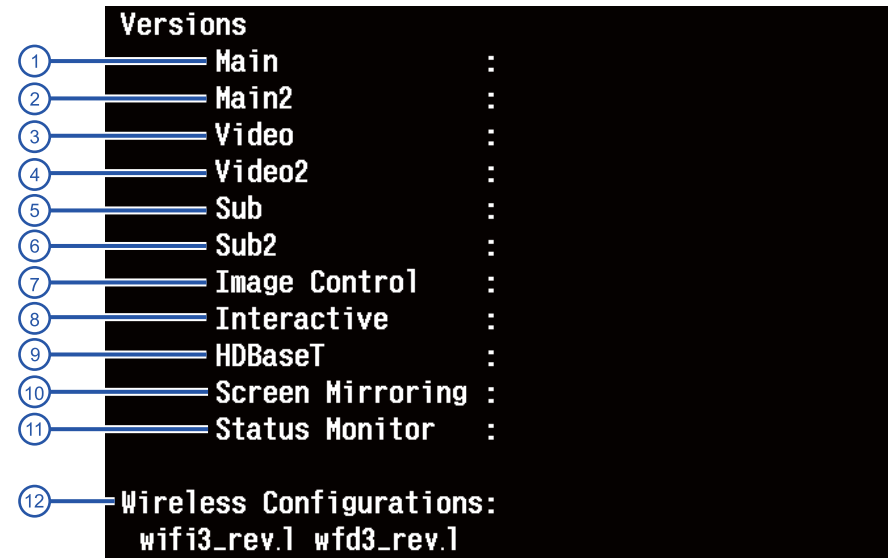

No.	Item
1	Main firmware version
2	Main2 firmware version
3	Video processor firmware version
4	Video2 processor firmware version
5	Sub firmware version
6	Sub2 firmware version
7	Image Control firmware version
8	Interactive firmware version
9	HDBaseT firmware version
10	Screen Mirroring firmware version
11	Status Monitor firmware version
12	Wireless device configurations

AS MENU: 3RD PAGE

Time information is displayed.

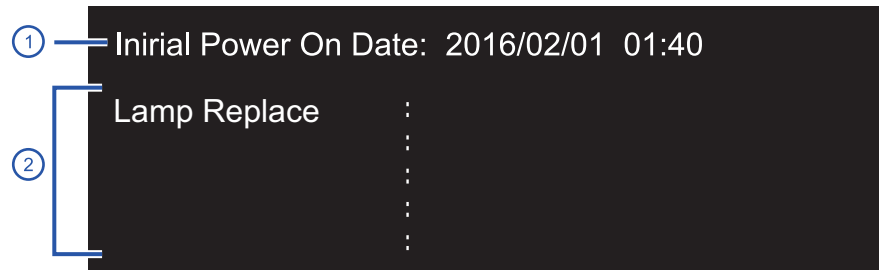

No.	Item
1	Time when the unit is first switched on by the user
2	Time of replacing the Lamp

AS MENU: 4TH PAGE

Error and warning histories are displayed.

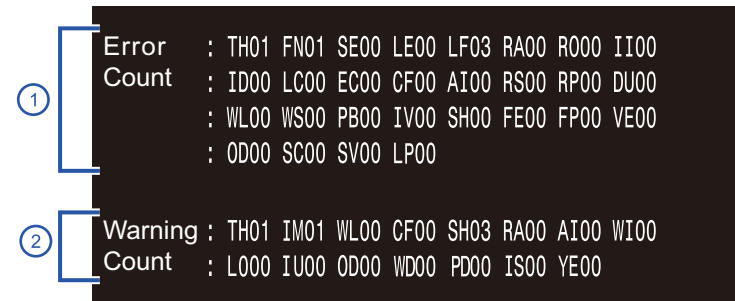

No.	Item
1	Error count
2	Warning count

About the information of Fan (FN), Sensor of temperature (SE) (=Thermostat) and Internal Error (II) in the “CD (Error Name)” displayed the “Error Log”, you can identify the trouble part by seeing ID (Device Code) and the following table. (ID information: [Troubleshooting from the Device Names](#))

Displayed with 2-digit number (00-99). For over 99, “99” is displayed. (Not cleared to “0”).

Item	Error Code	Description	Representation
Error Count	TH	Internal overheat	Displayed with 2-digit number (00-99). For over 99, "99" is displayed. (Not cleared to "0").
	FN	Fan error	
	SE	Thermistor error	
	LE	Lamp burnt out	
	LF	Lighting failure	
	RA	Internal error (RAM)	
	RO	Internal error (ROM)	
	II	Internal error (I2C)	
	ID	Internal error (DR)	
	LC	Lamp cover open	
	EC	Electric double layer condenser connection error	
	CF	Cinema filter error	
	AI	Auto Iris Error	
	RS	Sub System error (ROM)	
	RP	Sub-system communication error (PW error)	
	DU	DVD Unit error	
	WL	wind lowered	
	WS	Wind Sensor error	
	PB	Power Supply (Ballast) Error	
	IV	Internal error (Video sub-processor error)	
SH	Shutter error		
FE	Cooling system error (Peltier device)		
FP	Cooling System error (Pomp)		
Error Count	VE	Exhaust Duct Shutter error	Displayed with 2-digit number (00-99). For over 99, "99" is displayed. (Not cleared to "0").
	OD	Obstruction Detecting error	
	SC	Stack Communication error	
	SV	Stack communication error (Version)	

Item	Error Code	Description	Representation
Warning Count	TH	High Temp Warning	Displayed with 2-digit number (00-99). For over 99, "99" is displayed. (Not cleared to "0").
	IM	Easy MP internal error	
	WL	wind lowered	
	CF	Cinema Filter warning	
	SH	Shutter warning	
	LI	Lens Iris warning	
	AI	Static Iris warning	
	WI	Wireless HD warning	
	LO	Lens Cover warning	
	IU	Interactive unit Internal error	
	OD	Obstruction Detecting warning	
	WD	Wireless Display internal error count	

AS MENU: 5TH PAGE

Warning histories are displayed. The last 4 error logs are displayed (the latest on top). You can switch the pages by up/down button of the remote controller.

None is displayed if there is no error.

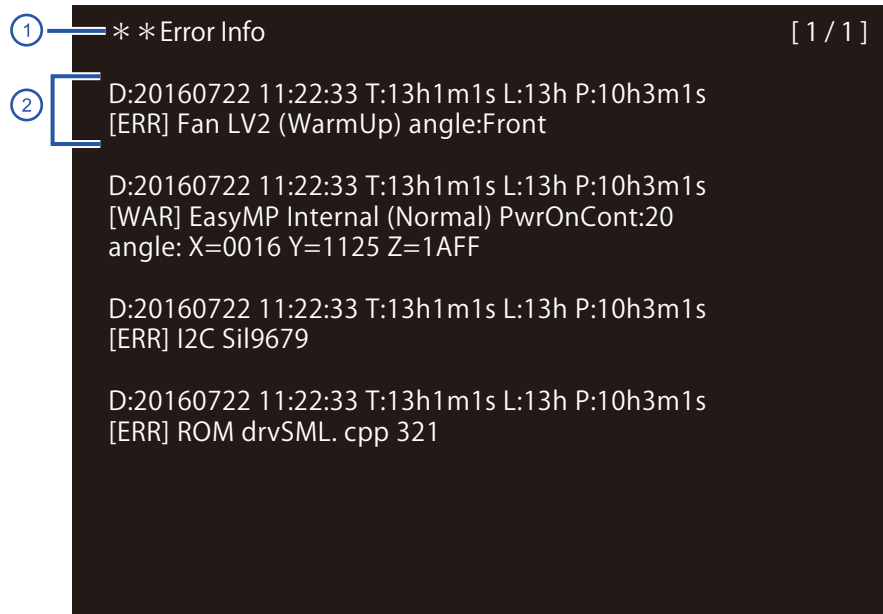

No.	Item
1	Warning item
2	Warning log (The latest warning log is displayed on the top.)

Error Log	
D: Date Time T: Lamp Time 1 L: Lamp Time 2 P: Lamp Time 3 [ERR] Error name (Error code), Device ID, Angle Error Detail Information	
Date	yyyy_mm_dd
Time	hh_mm_ss
Lamp Time 1	Total Time
Lamp Time 2	Low Brightness Time
Lamp Time 3	Elapsed Time
Error name	Error Name P.179
Error Name	Error Name P.179
Device ID	*Grey cell is Non-applied ID for this model. P.179 Device ID name (sensor error) P.180 Device ID name (internal error) P.182
Error Detail Information	IC2 error: Add slave/sub address
	ROM error: Add Inspection of Troubling Location
	Lens shift error: Add Lens shift position
Angle	x=0000 y=0000 z=0000

Warning Log	
D: Date Time T: Lamp Time 1 L: Lamp Time 2 P: Lamp Time 3 [WAR] Warning Name (Warning Code)	
Date	yyyy_mm_dd
Time	hh_mm_ss
Lamp Time 1	Total Time
Lamp Time 2	Low Brightness Time
Lamp Time 3	Elapsed Time
Error name	Warning name P.179
Error Name	Warning name P.179

AS MENU: 6TH PAGE

State of when temperature errors are displayed.

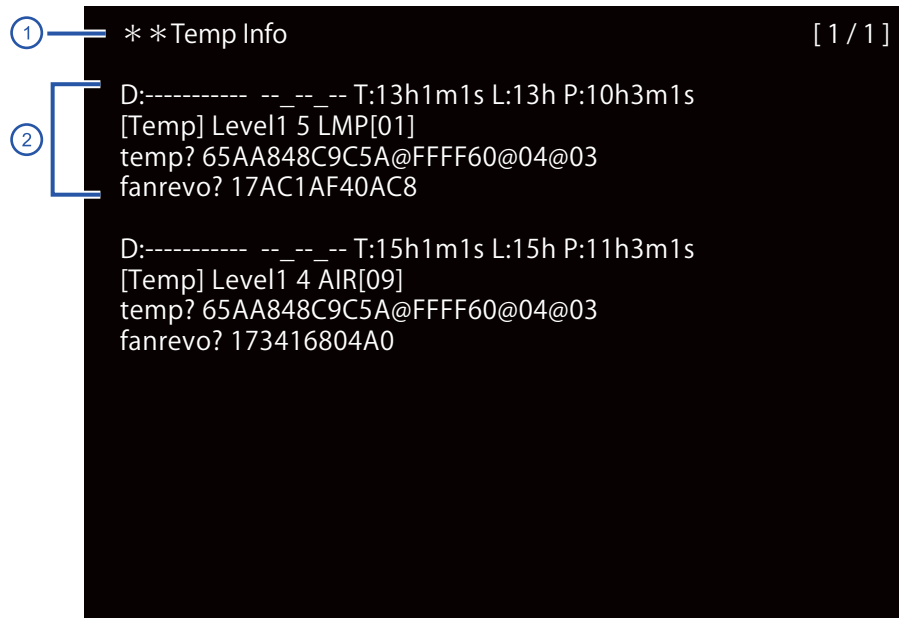

No.	Item
1	Warning item
2	Warning log (The latest warning log is displayed on the top.)

Temperature Log	
D: Date Time T: Lamp Time 1 L: Lamp Time 2 P: Lamp Time 3 [TEMP]Level Device ID temp? <Temperature Information> fanrevo? <FAN Information>	
Date	yyyy_mm_dd
Time	hh_mm_ss
Lamp Time 1	Total Time
Lamp Time 2	Low Brightness Time
Lamp Time 3	Elapsed Time
Level	Level nn (When nn is larger than 3)
Device ID	Device ID name (sensor error) P.180
Temperature Information	Value obtained by temp?
FAN Information	Value obtained by fanrevo?

AS MENU: 7TH PAGE

Information obtained when the following operations are performed is displayed.

The type of the operation is displayed on the second line.

- [Power On] Power On
- [Power Off] Power Off
- [CMODE] Color Mode Switching
- [INFO] Input Source Switching

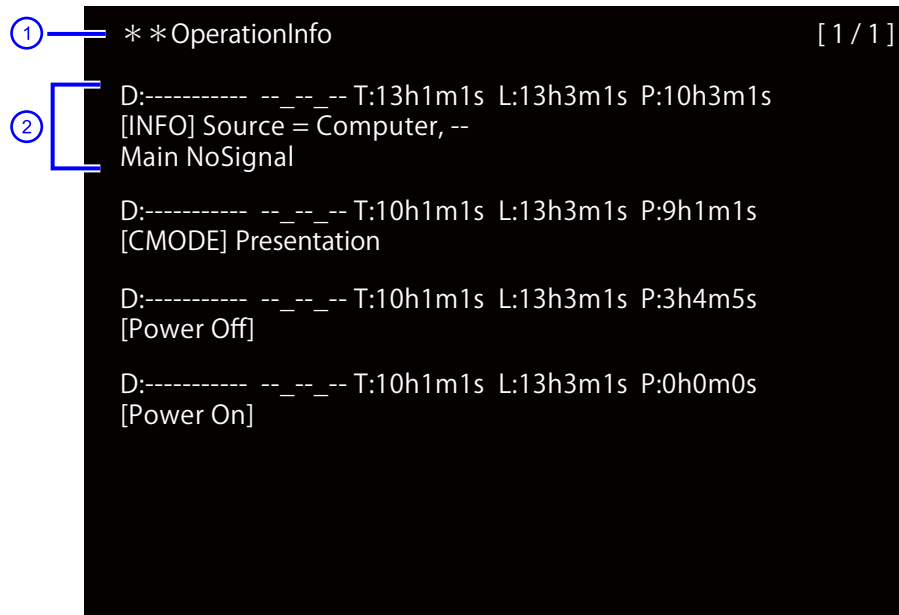

No.	Item
1	Warning item
2	Error log (The latest warning log is displayed on the top.)

Operation Log (Operation Info)	
D: Date Time T: Lamp Time 1 L: Lamp Time 2 P: Lamp Time 3 [Power On]/[Power Off]/[CMODE] Cmode/[INFO] Source Main Sub Main Signal Information*1 Sub Signal Information*1	
Date	yyyy_mm_dd
Time	hh_mm_ss
Lamp Time 1	Total Time
Lamp Time 2	Low Brightness Time
Lamp Time 3	Elapsed Time
Cmode *2	Set color mode
Main Source*1	Source name P.182
Sub Source*1	Source name P.182
Main Signal Information*1	Main Signal Information (includes image on the left side) No Signal is displayed if there is no signal.
Sub Signal Information*1	Signal Information of image on the left side of two images. Nothing is displayed if not Split Screen is selected.

Note: *1 Only displayed for [INFO]
*2 Only displayed for [CMODE]

□ Error Name/Warning Name/Device ID/Source Name List

*Grey cell is Non-applied ID for this model.

■ Error Name

Error	Display
Upper layer inner error	Inner (RO)
Sensor error	Thermistor (SE)
Temperature error	Temp (TH)
Fan error	Fan (FN)
Lamp error	Lamp (PB)
Lamp lit error	Lamp On (LF)
Lamp Failure	Lamp Off (LF)
Lamp cover open error	Cover Open (LC)
RAM H/W error	RAM (RA)
ROM H/W error	ROM (RO)
I2C H/W error	I2C (II)
DR inner H/W error	DR (ID)
Other H/W error	Other HW (RO)
Sub system communication error	Sub System (RP)
Sub System error (ROM)	Sub System ROM (RS)
Electric capacitor error	Capacitor (EC)
Ballast error	Ballast (PB)
wind lowered	Air (WL)
Wind sensor error	Air Sensor (WS)
Exhaust Duct Shutter error	Exhaust Shutter (VE)
Auto Iris Error	Auto Iris (AI)
Obstruction Detecting error	Obstacle (OD)
IF Board discrimination error	IF Mismatch (IC)
Stack communication error (SC)	Stack (SC)
Stack communication error (SV)	Stack Ver (SV)
Ballast mismatch error	Ballast Mismatch (BA)
No Lens error	Lens Attach (LA)
Lens shift error	Lens Shift (LP)

Error	Display
Out of Lens shift range	Lens Out (LP)
Cinema filter error	Cinema Filter (CF)
Laser error	Laser (YE)
Quartz N Polarizer error	Laser CPD (AP)
Peltier error	Peltier (FE)
Pump error	Pump (Fp)
Instability error	Voltage (PV)
Portrait Lamp life error	P Lamp Life (LL)

■ Warning name

Error	Display
High Temp Warning	Temp (TH)
Warning to replace Lamp	Lamp Life (LL)
Easy MP internal error	EasyMP (IM)
wind lowered	Air (WL)
Filter cleaning	Filter Clean (WT)
No filter warning	Filter (WN)
Application error (IML connecting error)	Application (IM)
Pre-obstruction detecting warning	Obstacle Pre (OD)
Obstruction Detecting warning	Obstacle (OD)
WFD error	WFD (WD)
Posture warning	Posture (PD)
Setting value warning	Set Posture (IS)
Cinema filter warning	Cinema Filter (CF)
Laser warning	Laser (YE)

■ Device ID name (fan error)

ID	Display
00	LV0
01	LV1
03	LMP

ID	Display
04	PBS
05	EX
06	PBS2
07	EX1
10	POWER
11	LV2
12	LV3
13	LUMI
14	PS
15	PB
16	LMP2
17	PS2
18	EX2
19	PEL
1A	LMP3
1B	PUMP
1C	PEL1
1D	PEL2
1E	YLD
1F	PHW
22	LD1
23	LD2
24	BDM
25	ROUT1
26	ROUT2
27	RIN1
28	RIN2
29	LVR
2A	LVG
2B	LVB
2C	LSM

ID	Display
2D	EX3
2E	PWIN
2F	PWOUT
30	LDDR
31	PEL3
32	PEL4

■ Device ID name (sensor error)

ID	Display
00	LV
01	LMP
02	LMA
03	PBS
04	AMIBENT
05	PWR
06	WIND
07	IRIS
08	SCI
09	AIR
0A	PB
0B	LWR
0C	PS2
0D	WIHD
0E	IM
0F	LV2
10	EX
11	YLD
12	PHW
13	BLD
14	YDR
15	BDR

ID	Display
16	PJ1
17	PJ2
18	PJ3
19	Filter_Block
1A	AU_TH
1B	SQ_TH
1C	LMP(2)
1D	PS (1)
1E	BA(Ballast)2
1F	PEL
20	POP
22	DR_TH
23	PFC (1)
24	HDBT
25	VIC
26	SWL
27	BB1
28	BB2
29	P-Shift
2A	LVR
2B	LVG
2C	LVB
2D	BAA
2E	PSA
2F	LD1
30	LD2
31	PFC2
32	PS0
33	PFC0
34	PS3
35	PFC3

ID	Display
36	PS4
37	PFC4
38	AIR2
39	CPIN
3A	CPOUT
3B	CA1
3C	CA2
3D	INA1
3E	LDIN1
3F	LDOUT1
40	LDIN2
41	LDOUT2
42	EX1
43	EX2
44	DIF
45	LLC0
46	LLC1
47	LLC2
48	LLC3
49	LLC4
4A	LDDR0
4B	LDDR1
4C	LDDR2
4D	LDDR3
4E	LDDR4
4F	SML1
50	SML2
51	FOCUS_AIR
52	FOCUS_LENS
53	FOCUS_PB
54	LDAVE

■ Device ID name (laser error, warning)

ID	Display
01	Ary1
02	Ary2
03	Ary3
04	Ary4
05	Ary5
06	Ary6
0B	Drv1
0C	Drv2
0D	Drv3
0E	Drv4
0F	Drv5
10	Drv6
15	Drv Com
16	Motor
17	Motor Com
1B	Ary1
1C	Ary1
1D	Ary2
1E	Ary2
1F	Ary3
20	Ary3
25	Drv1
26	Drv2
27	Drv3
28	Drv4
29	Drv5
2A	Drv6
2B	Src

■ Device ID name (internal error)

ID	Display
00	CAMERA

■ Source name

Source	Display
C-VIDEO	Video
S-VIDEO	S-Video
BNC	BNC
DSUB	Computer
DSUB2	Computer2
DVI	DVI
HDMI	HDMI
HDMI2	HDMI2
HDMI3	HDMI3
DisplayPort	DisplayPort
SDI	SDI
HDBaseT	HDBaseT
WFD	Screen Mirroring
USB	USB
USB Display	USB Display
LAN	LAN
MessageBroadcast	Message Broadcast
NW Menu	Network Menu
Schedule	Schedule Menu
WB Menu	White Board Menu
USB	USB
USB2	USB2
WhiteBoard	WhiteBoard
MPP	Participant list
RDP	RDP

AS Menu: 8th Page

The error log of the ballast is displayed. The last 7 error logs are displayed (the latest on top). None is displayed if there is no error.

```

①—PB Log 1:
ERR      LOG      CD
②— FFFFFFFF FFFFFFFF LE
  FFFFFFFF FFFFFFFF FF
  FFFFFFFF FFFFFFFF LF
  FFFFFFFF FFFFFFFF FF
  FFFFFFFF FFFFFFFF LE
  FFFFFFFF FFFFFFFF FF
  FFFFFFFF FFFFFFFF LF
  FFFFFFFF FFFFFFFF FF
  FFFFFFFF FFFFFFFF LE
  FFFFFFFF FFFFFFFF FF
    
```

No.	Item
1	Page number of ballast error log
2	Log on ballast error Second paragraph is information of TEMP.

4.1.2 Confirmation method using IPS tool

Even when a projector can't be projected, the error name can be checked by connecting PC or using USB memory.

4.1.2.1 Preparation

1. Get the latest edition of the following tool from Tech Exchange.

Tool Name	Remark
IPS tool*1	Please install in PC beforehand.
V com Driver*2	Please install in PC beforehand.

(*1) The latest edition can be downloaded from TI No.AP14-0916-01 [1103]. The operating method details of IPS tool can be confirmed by TI No. "The Operation Guide to use IPS-Tool".

(*2) The latest edition can be downloaded from Tech Exchange No. DR09-0602-01. Please download the latest edition.

4.1.2.2 Confirmation method which connects PC with projector

It's connected by a USB cable (Type-A-Type-B) and checked using IPS tool.

4.1.2.2.1 Confirmation method

1. Disconnect the power cord from the projector and check that all of the indicators on the projector are off.
2. Connect the power cord to the projector while pressing the [Enter] button on the Control Panel or remote controller. When the LED panel on the projector flashes four times and then lights up, release the [Enter] button.
3. Connect the projector to the PC using USB cable.

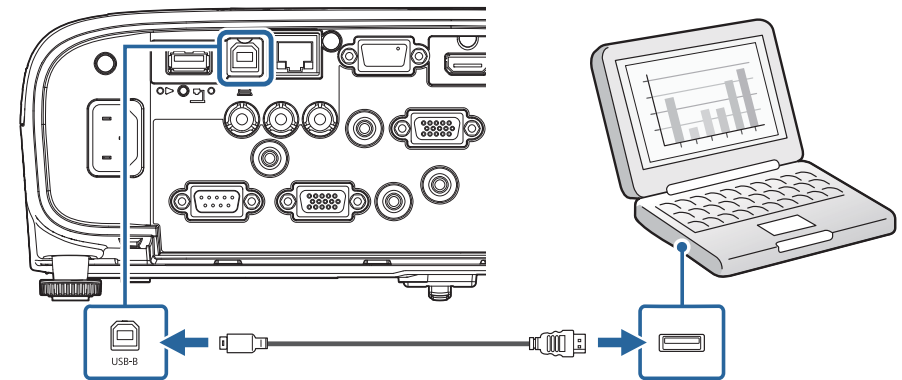

4. Press the [Power] button on the projector or the remote controller.
5. Start IPS tool.

6. Click to the [COM Port Setting].

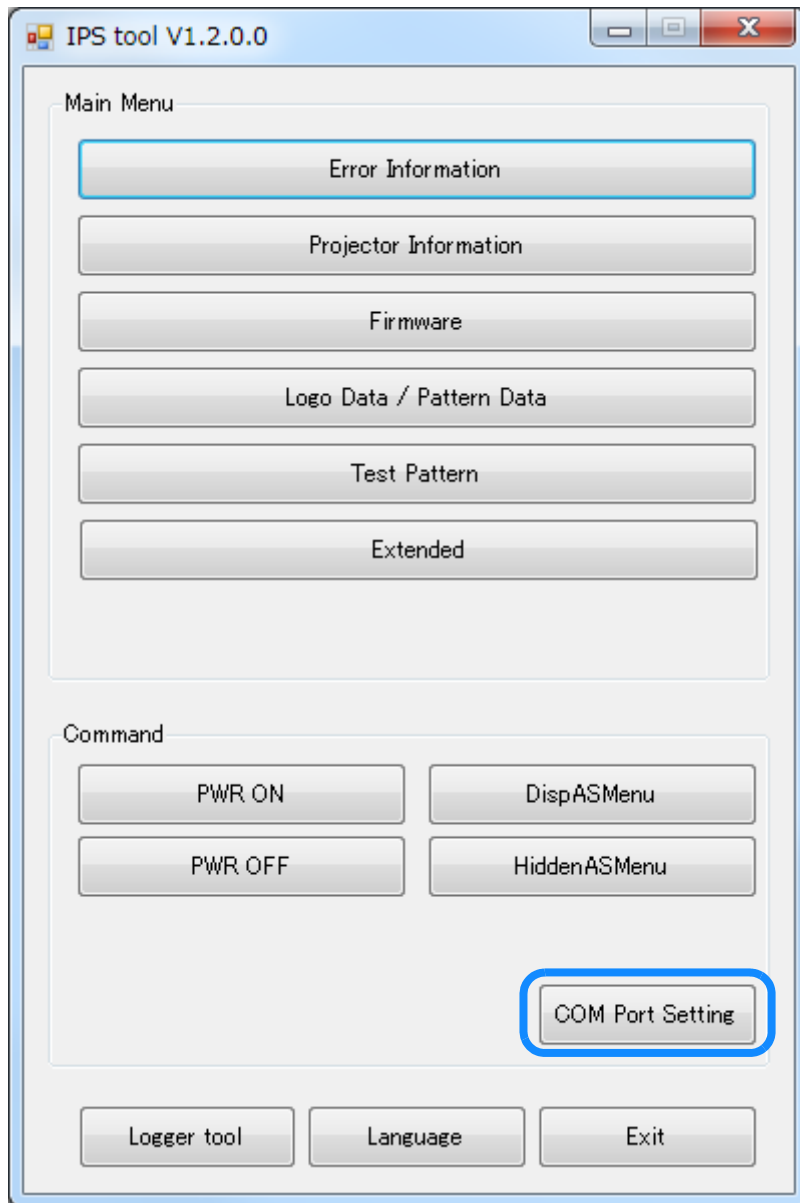

7. Select an arbitrary port and click [Connect test]

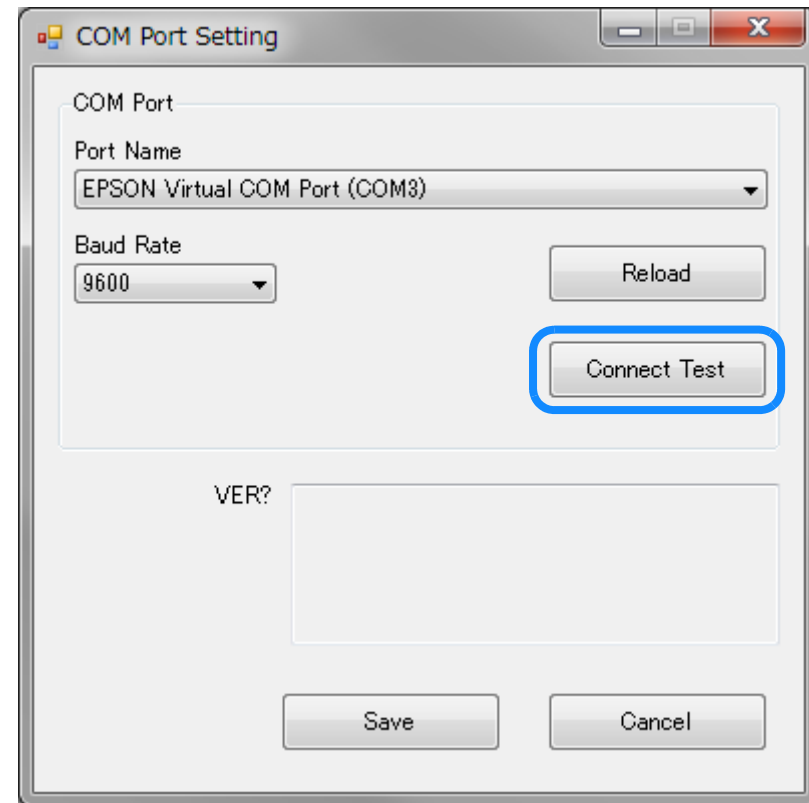

8. When the communication succeeds, [OK] is clicked.

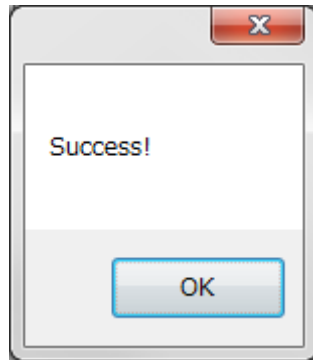

9. Confirm the firmware version in the VER? Column.

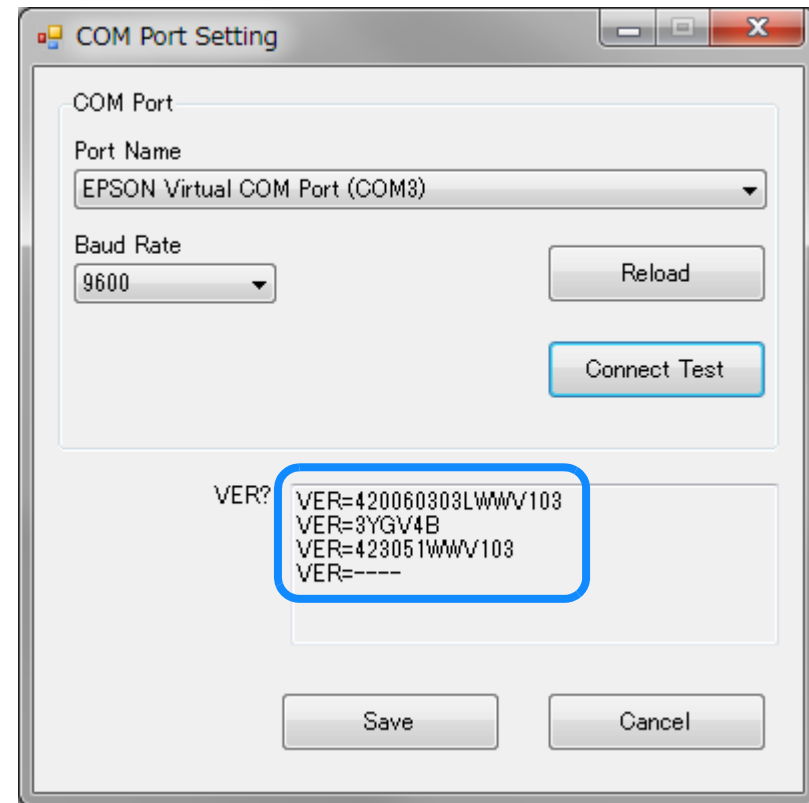

When the communication is not normal then error is displayed. Please confirm the communication status.

10. If setting is OK, [Save] is clicked.

11. [Error Information] of TOP menu is clicked.

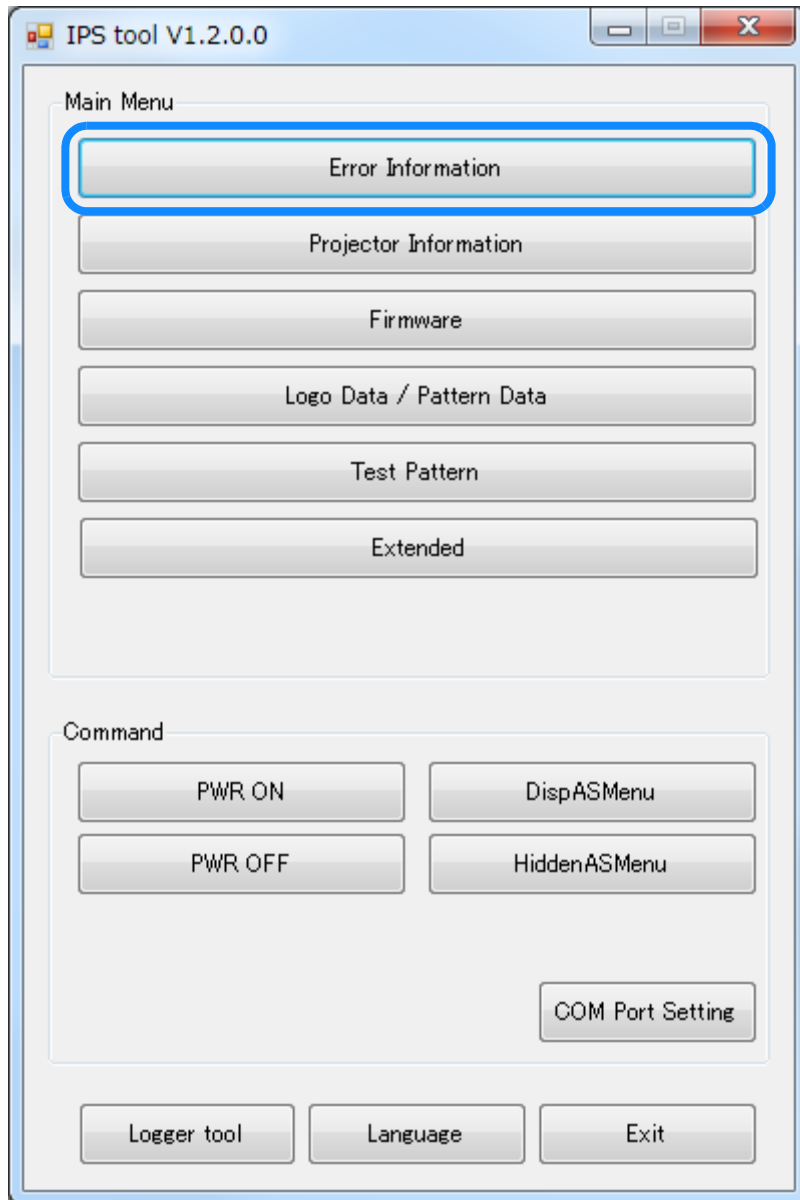

12. [Detect Projector] and [Get Data] is clicked and display the error information. The cell with the numerical value is displayed in red. (Excluding the Time information)

Note: Please disregard it though “Lamp ON Counter / Lamp OFF Counter” is displayed in red. (This is a specification of IPS tool.)

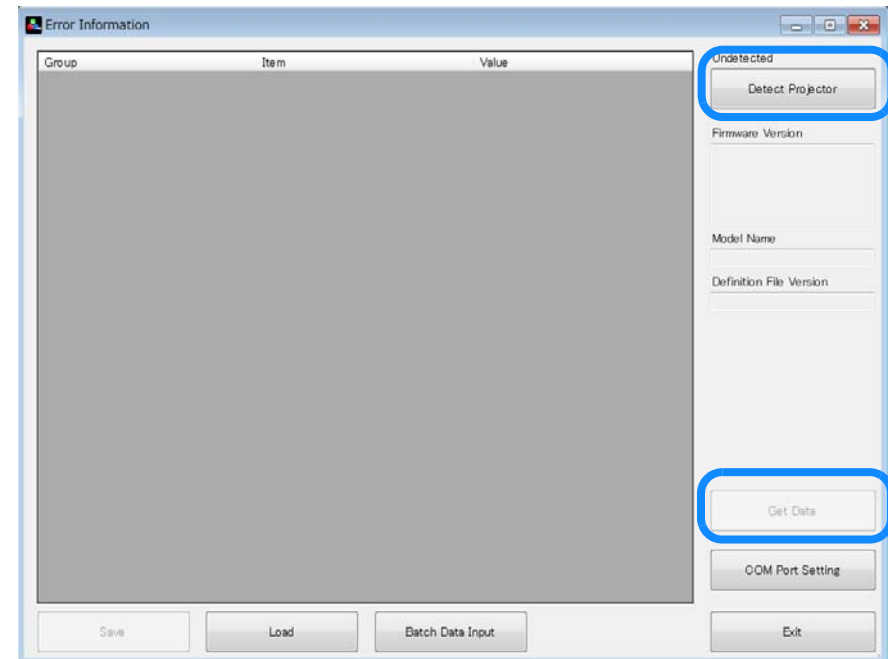

13. When the acquired data is preserved, [Save] is clicked to an arbitrary folder. By sharing the saved file, the IPS tool user can check the error information.

14. [Load] is clicked, you can read the preserved data from an arbitrary folder.

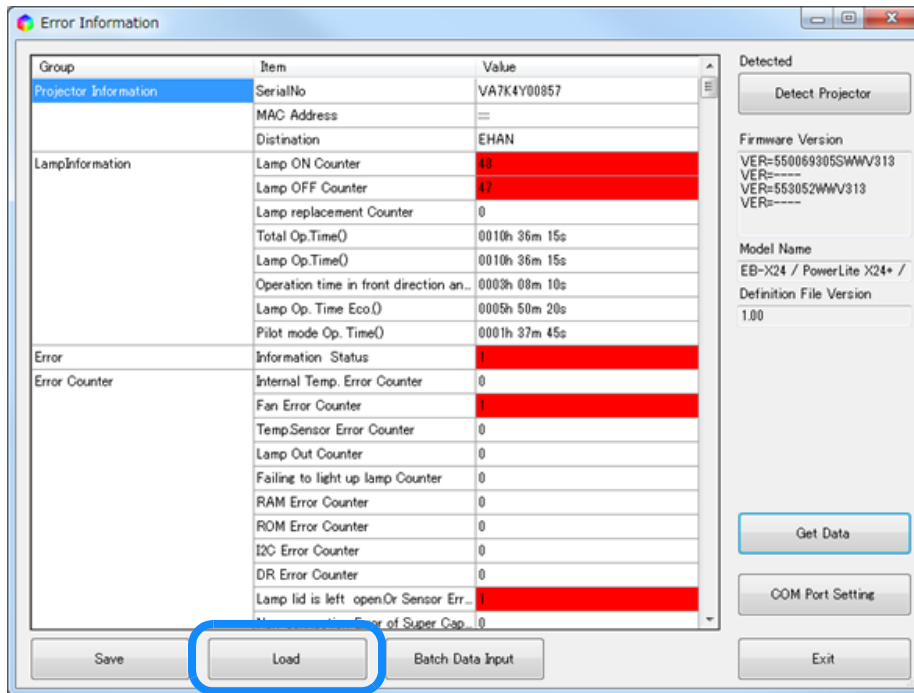

15. The sub screen closes when [Exit] is clicked, and the main screen is displayed.

16. Close a main screen of a IPS tool and take out power cord of the body after the confirmation.

4.1.2.3 Confirmation method using a USB memory

A data file of the body is preserved to a USB memory. The data in the USB memory is confirmed using ISP Tool.

4.1.2.3.1 Acquisition method of data file

A data file of the body is preserved and acquired to a USB memory by the following procedure.

1. Disconnect the power cord from the projector and check that all of the indicators on the projector are off.
2. Connect a USB memory to the USB-A terminal of the projector.

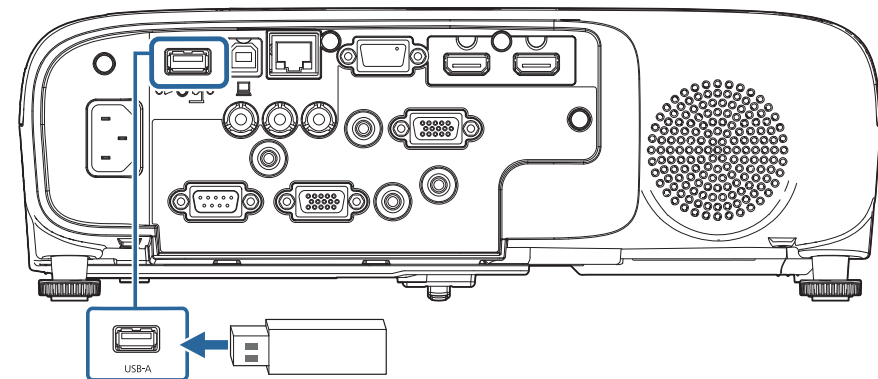

3. Put power cord in the body while pressing the [Esc] button of the remote controller.

4. When all indicators light up, release the [Esc] button.
When the indicator changes to flash, the data file is written to the USB memory. When the writing is completed successfully, the projector turns into the stand-by state.

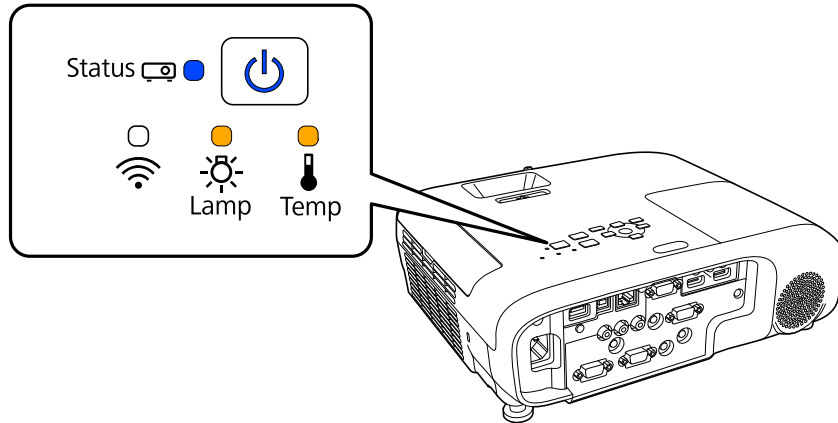

CAUTION

- During writing a data file in, don't remove power cord or USB memory from a projector. If the power cord or the USB memory is removed, the projector may not start normally.

5. Remove the USB memory.

4.1.2.3.2 Confirmation method

1. Connect the USB memory in which a data file was written to PC.
2. Start IPS tool, and click [Error Information]. (PC screen: [Confirmation method which connects PC with projector P.184](#))
3. When [Batch data input] is clicked, [PJCONFDATA.BIN] is read from USB memory.

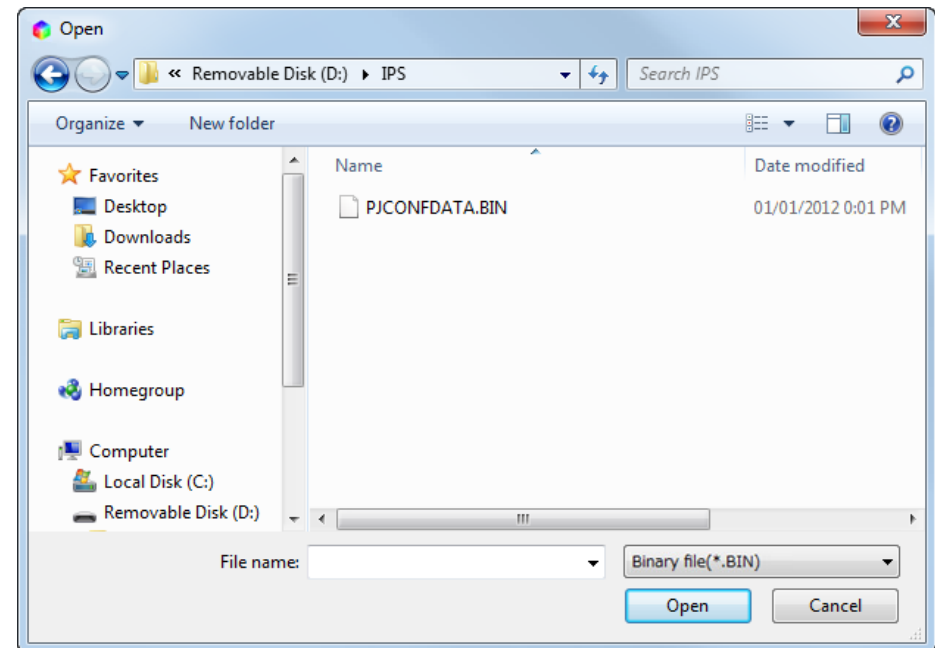

4. Acquired information is indicated. (PC screen: [Confirmation method which connects PC with projector P.184](#))

4.1.3 Initializing (Resetting)

Initialization of the following information can be done by performing the procedure below when the AS menu is displayed.

Type	Clearing the Lamp Information	Clearing the AS Information	Clearing the Log Information
Operation Item	While the AS menu is displayed, press and hold the [Source Search] and [Up] buttons together on the projector for 10 seconds.	While the AS menu is displayed, press and hold the [Source Search] and [Down] buttons together on the projector for 10 seconds.	While the AS menu is displayed, press and hold the [Right] button on the projector (or the remote controller) for 5 seconds or more, and press and hold the [Enter] button for 2 seconds or more within 3 seconds after that.
Total Operation Time	N/A	Reset to 0	N/A
Lamp Operation Time (3D/H/M/L/UL)	Reset to 0	Reset to 0	N/A
Lamp ON	Reset to 1	Reset to 1	N/A
Lamp OFF	Reset to 0	Reset to 0	N/A
Lamp Replacement	Add 1 to the current value	Reset to 0	N/A
Error Log	N/A	N/A	Spacing (Initialized to the status of acquiring none)
Error Count	N/A	N/A	Reset to 0
PB Log 1	N/A	N/A	Spacing (Initialized to the status of acquiring none)
Information	N/A	N/A	Delete
Other	Record the time of operation in the time of Lamp replacement. (EB-FH52/992F, EH-TW750)	Initializes the forced low brightness transfer times. (to 0)	Initializes the warning count.