

CD43-E CD53-E

Outdoor Dome Camera

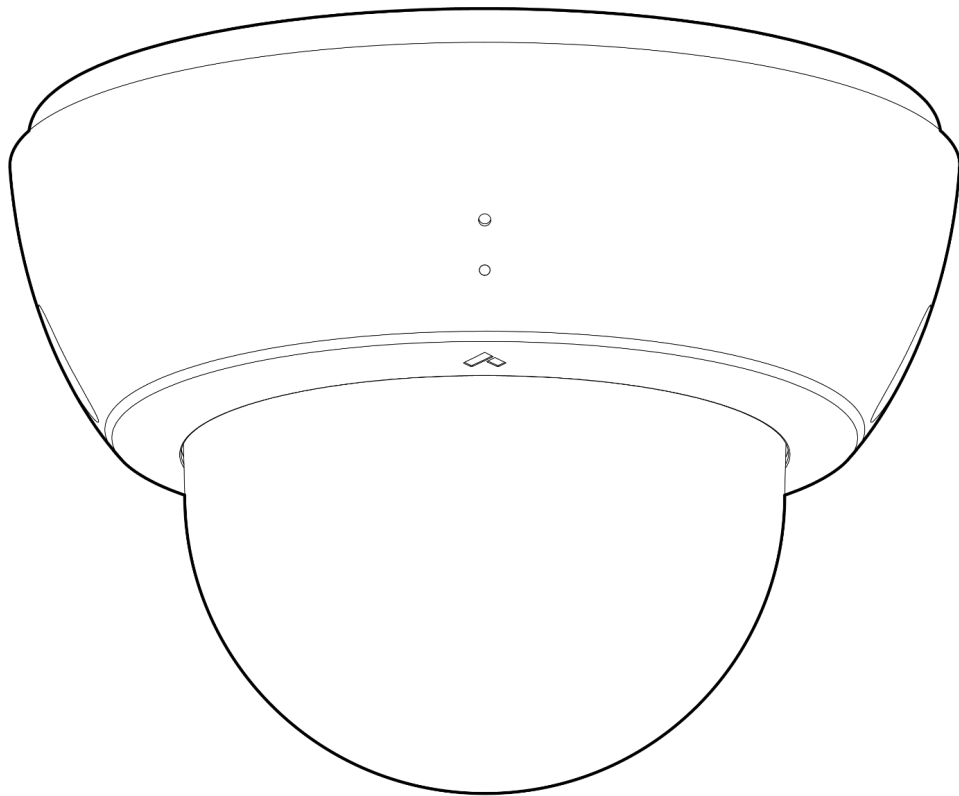

Document

Document Details

Version

V1.0 20250122

(V1.0 published 20250122)

Product Models

This install guide pertains to model CD43-E-HW,
CD53-E-HW.



© Copyright 2025 Verkada Inc. All rights reserved.

Verkada and the Verkada logo are registered trademarks or service marks of Verkada Inc. (“Verkada”). All other trademarks are the property of their respective owners.

Verkada may make changes to this document at any time without notice. The information presented herein may be inaccurate or outdated, and Verkada is under no obligation to maintain it. ALL INFORMATION IS PROVIDED “AS-IS” AND WITHOUT ANY WARRANTIES, IMPLIED, EXPRESS, OR OTHERWISE. VERKADA DISCLAIMS LIABILITY FOR ALL DAMAGES, INCLUDING WITHOUT LIMITATION ANY DIRECT, INDIRECT, SPECIAL, INCIDENTAL, PUNITIVE, OR CONSEQUENTIAL DAMAGES, ARISING OUT OF USE OF THIS DOCUMENT.

Any intellectual property rights relating to Verkada products are and shall remain Verkada’s exclusive property. Use of any Verkada product is subject to Verkada’s end user agreement or other executed agreement with Verkada. No license, either expressed or implied, to use or distribute any Verkada product is granted under this document.

This document may not be sold, resold, licensed or sublicensed and may not be transferred without Verkada’s prior written consent. No part of this document may be reproduced in whole or in part without the express written consent of Verkada.



What's in the box

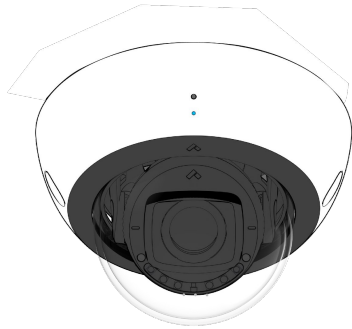

Outdoor Dome Camera

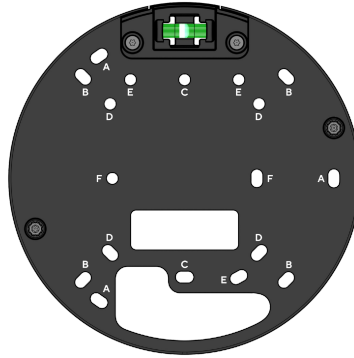

Mount plate
(Attached to camera)



T10 Torx Security Screwdriver

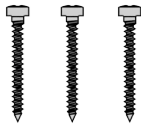

Wall Mount Screws (3 pcs)
Length: 25mm Diameter: 4mm
Drive: #2 Phillips



Desiccant (1 pc)

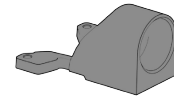

Conduit Adapter

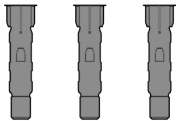

Wall Anchors (3 pcs)



Cable Gland (1 pc)
Size: 6.5-7.5mm



Cable Gland (1 pc)
Size: 5.0-6.5mm
(Attached to camera)

What you'll need

- A working Internet connection.
- 802.3at/af Power over Ethernet (PoE) switch, or a PoE injector. For operation below -20°C , use 802.3at PoE
- A smartphone or laptop
- A #2 Phillips screwdriver or power drill with a #2 Phillips driver bit
- 1/4 inch (6.5mm) drill bit for wall anchors
- 1/8 inch (3mm) drill bit for pilot holes
- A Cat5 or Cat6 Ethernet cable with a 0.2-0.3 inch outside diameter (5-7.5mm)

Connect

For easy registration and setup, scan the QR code on the product.

If you prefer to manually register your product, please proceed to: verkada.com/start



Overview

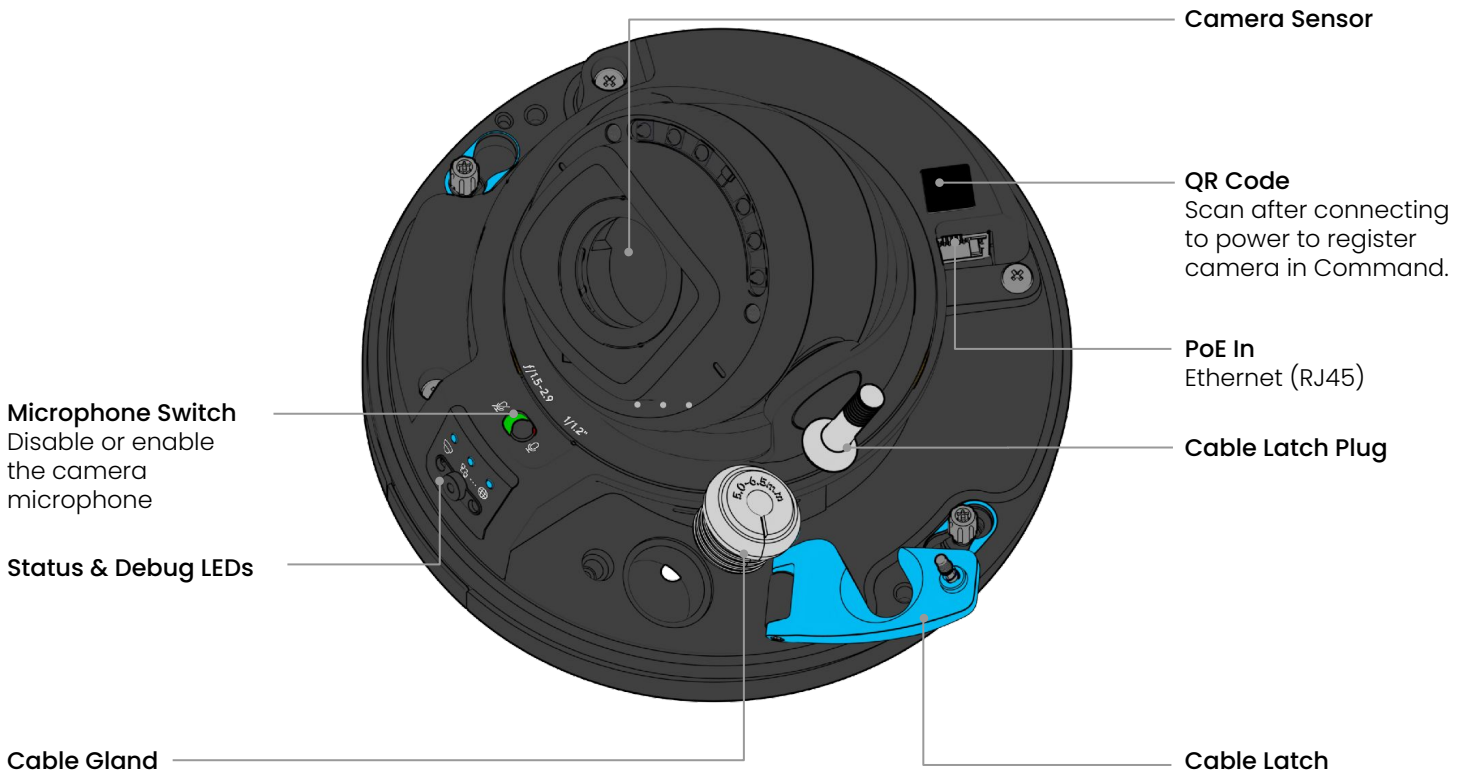

Mount Plate

- A Wall Mount
- B 4" Square Junction Box
- C Single Gang Junction Box
- D 3.5" Round Junction Box
- E Double Gang Junction Box
- F European Junction Box

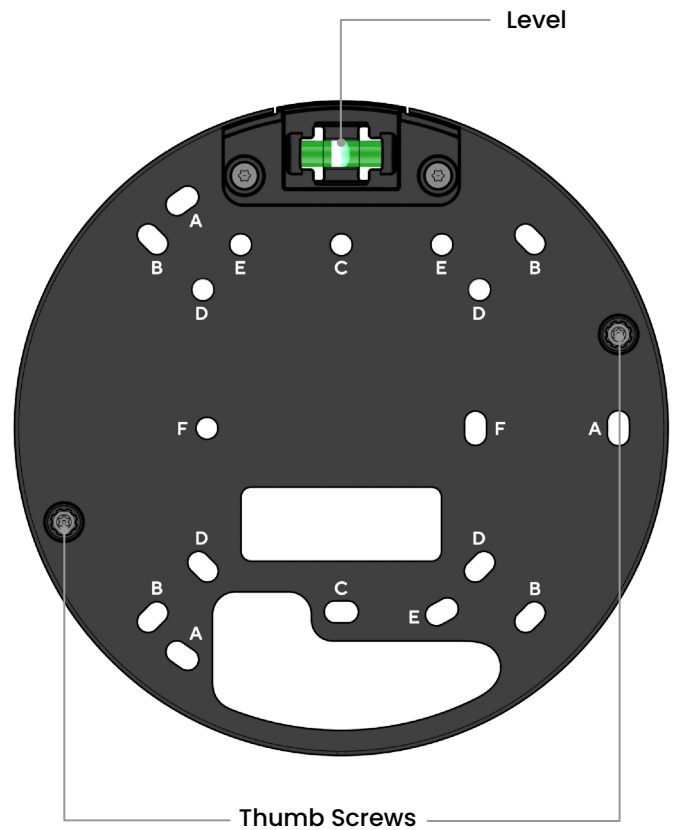

Introduction

Microphone Switch

The microphone switch allows you to physically disconnect the microphone in the camera unit, guaranteeing that no audio will be recorded.

Camera Audio is enabled by default.

To disable Camera Audio, move the switch into the left position.

Alternatively, Camera Audio can be disabled in your Command account.

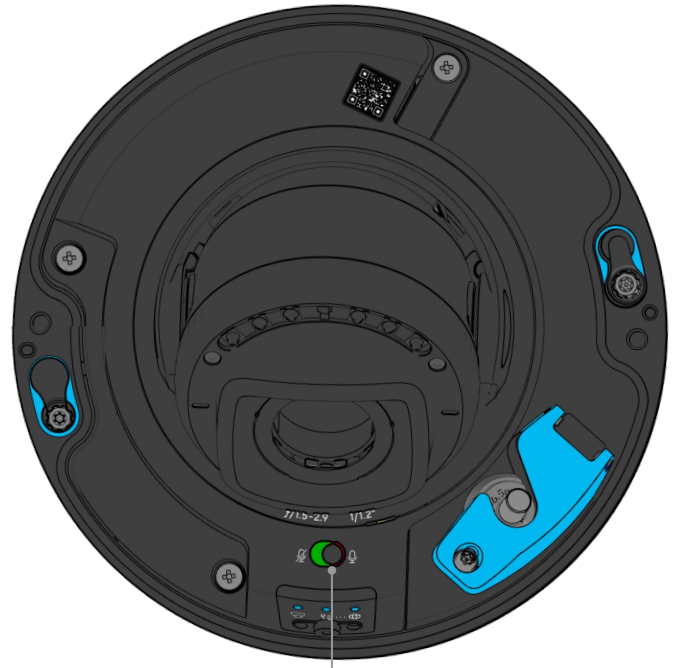

Microphone Switch

Microphone Enabled

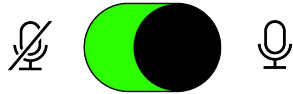

Microphone Disabled

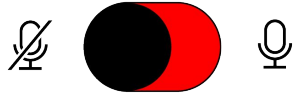

Placement

Mount the camera on the wall or ceiling. Try to keep the camera 8 to 10 feet above the ground.

For best night vision, avoid overhangs or obstructions, which may reflect the camera's IR illumination and reduce the image clarity in night mode.

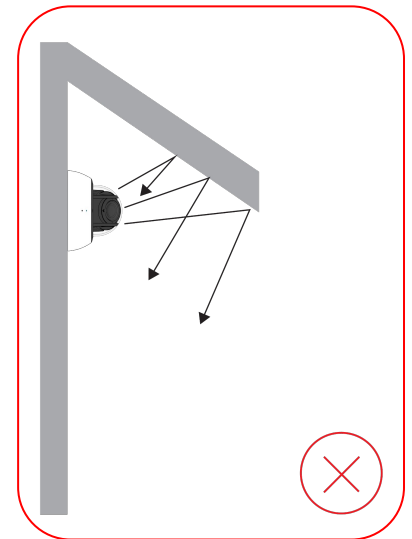
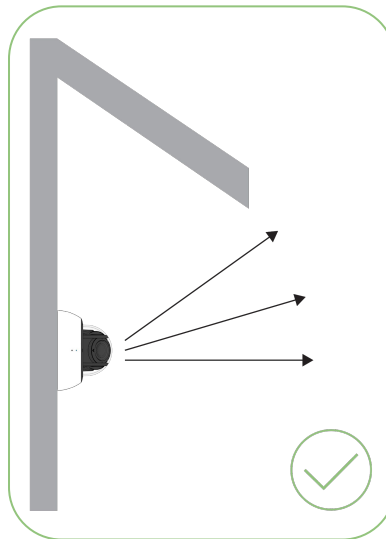

Exterior LED Behavior

General operation

- **Solid Blue**
Camera is running, connected, and recording data.
- **Solid Orange**
Camera is on and booting up.
- ☀ **Flashing Orange**
Camera is updating firmware.
- ☀ **Flashing Red**
Specific error, see "Network errors" below.
- **Solid Red**
Contact support.

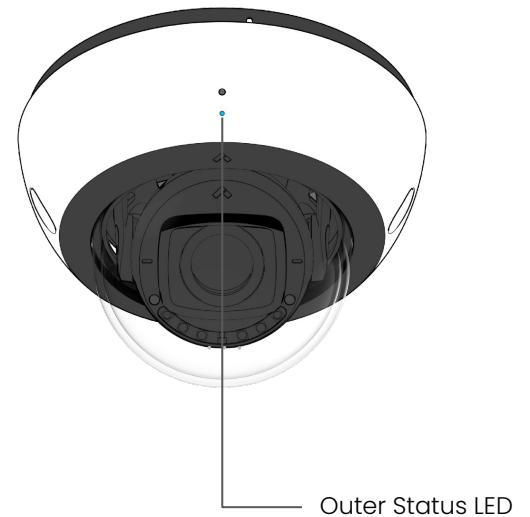

Network errors

When the camera top cover is on, an error will be communicated through the outer Status LED, which will flash a specific number of times depending on the error state.

1 Red - No IP Address

Camera has not received an IP address.

2 Red - Duplicate IP

Camera has detected duplicate IP addresses on the LAN.

3 Red - No Gateway

Camera is not able reach the configured Gateway.

4 Red - No Switch

Camera is connected with PoE, but unable to connect to the Switch.



Example of **5 Red** flashes on Outer Status LED

5 Red - DNS error

Camera is not able to resolve Verkada hostnames.

6 Red - NTP Error

Camera is not able to receive a response from the NTP Server.

7 Red - Not Connected to Command

Verkada endpoints are not reachable after boot up.

Interior LED Behavior

General operation

- **Solid Blue**
Camera is running, connected, and recording data.
- **Solid Orange**
Camera is on and booting up.
- ☀️ **Flashing Orange**
Camera is updating firmware.
- 🔴 **Flashing Red**
Specific error, see "Network errors" below.
- **Solid Red (x3)**
Contact support

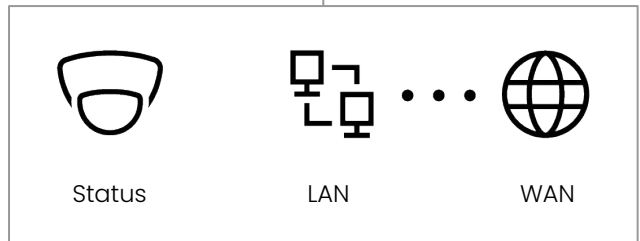
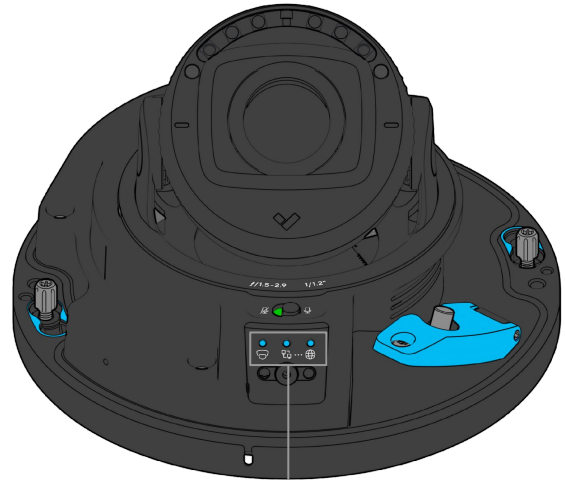

Network errors (Interior 'Debug' LEDs)

When the camera top cover is removed, the specific error will be communicated locally on the LAN or WAN debug LED, while the device Status LED will show solid red.



Example of **2 Red** flashes on LAN Debug LED

LAN errors

1 Red - No IP Address

Camera has not received an IP address.

2 Red - Duplicate IP

Camera has detected duplicate IP addresses on the LAN.

3 Red - No Gateway

Camera is not able reach the configured Gateway.

4 Red - No Switch

Camera is connected with PoE, but unable to connect to the Switch.

WAN errors

1 Red - DNS error

Camera is not able to resolve Verkada hostnames.

2 Red - NTP Error

Camera is not able to receive a response from the NTP Server.

3 Red - Not Connected to Command

Verkada endpoints are not reachable after boot up.



Preparation

Connect Device

Note: This step can be done after mounting, although registering the product first will ensure it is in working order prior to mounting.

Connect the CD43-E/53-E to your network using the Ethernet port located behind the cable door on the device.

For easy registration and setup, scan the QR code on the product.

If you prefer to manually register your product, please proceed to:

verkada.com/start

Enter the serial number printed on the back of the device, the packaging, or the order number.

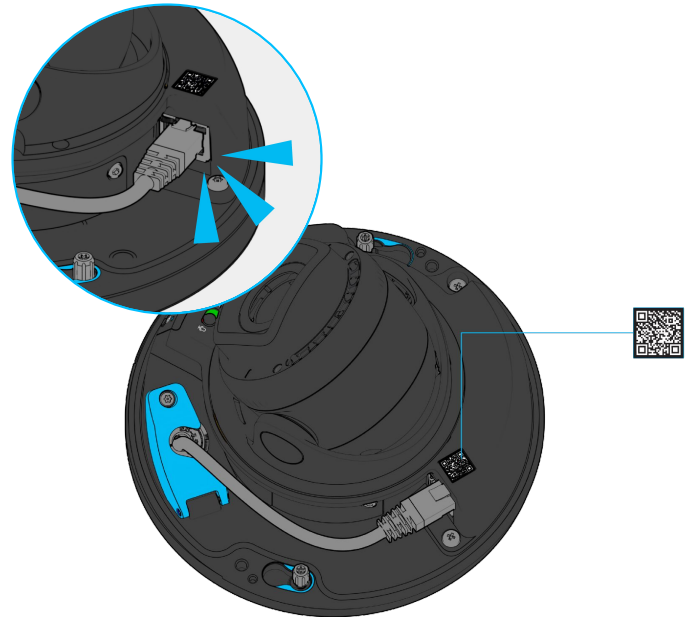

Installation

Mounting 1/6

Please keep the protective film adhered to the clear bubble until completing the final step of installation.

Unscrew the 2 Torx security screws on the top cover.

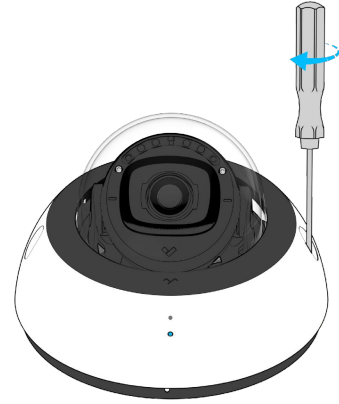

Lift the top cover and set it aside. Be careful to not scratch the clear bubble.

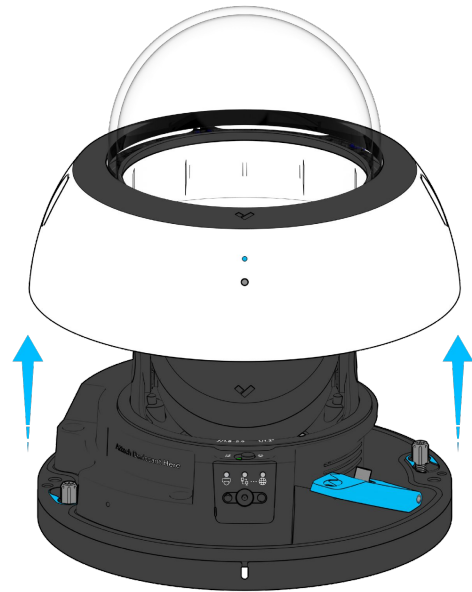

Installation

Mounting 2/6

Loosen the two thumbscrews on the mount plate, using the T10 Security Torx Screwdriver.

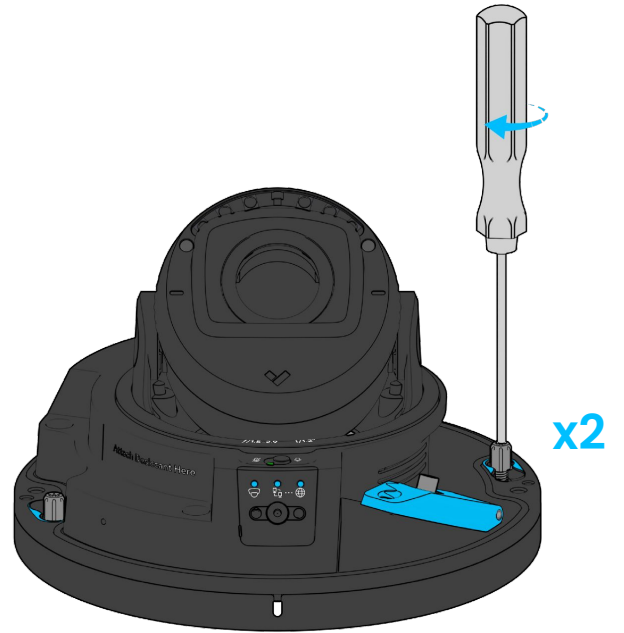

Twist the camera counter-clockwise and lift the camera off of the mount plate.

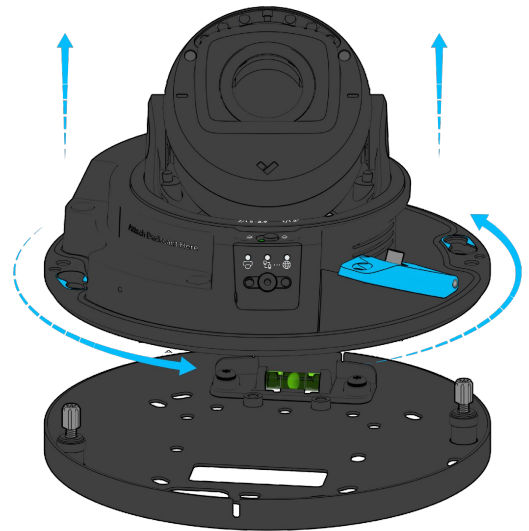

Remove and discard the desiccant adhered to the camera base.

Set the camera aside.

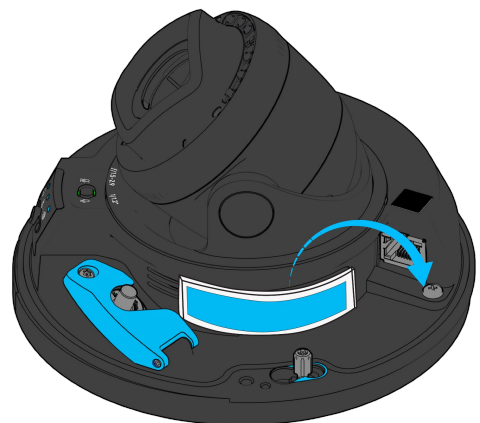

Installation

Mounting 3/6

Use the mount plate as a template to mark mounting holes and the the cutout for the cable.

Drill 5/64 inch (2mm) pilot holes.

If using wall anchors, drill 1/4" (6mm) pilot holes.

For a junction box mount, refer to the "hole pattern" page to use the appropriate hole pattern for mounting.

For a solid material like wood or metal, drill 1/8 inch pilot holes. Drive mounting screws directly into the pilot holes.

For drywall, drill 1/4 inch holes. Insert plastic anchors into holes and drive mounting screws into anchors.

Lead the Ethernet cable through the opening on the mount plate.

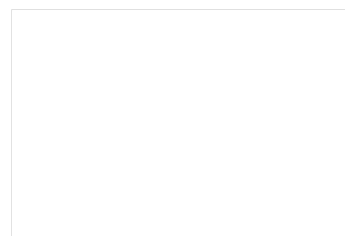
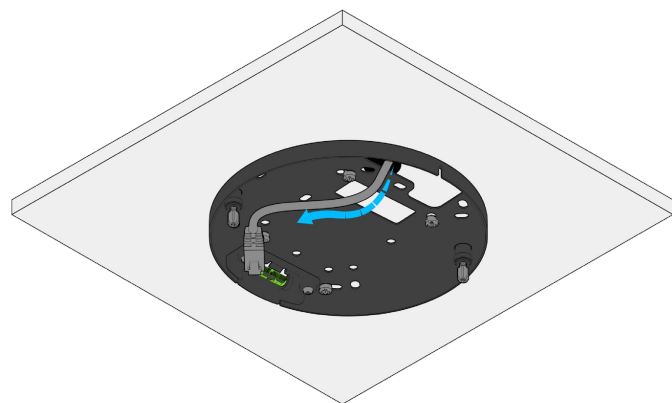
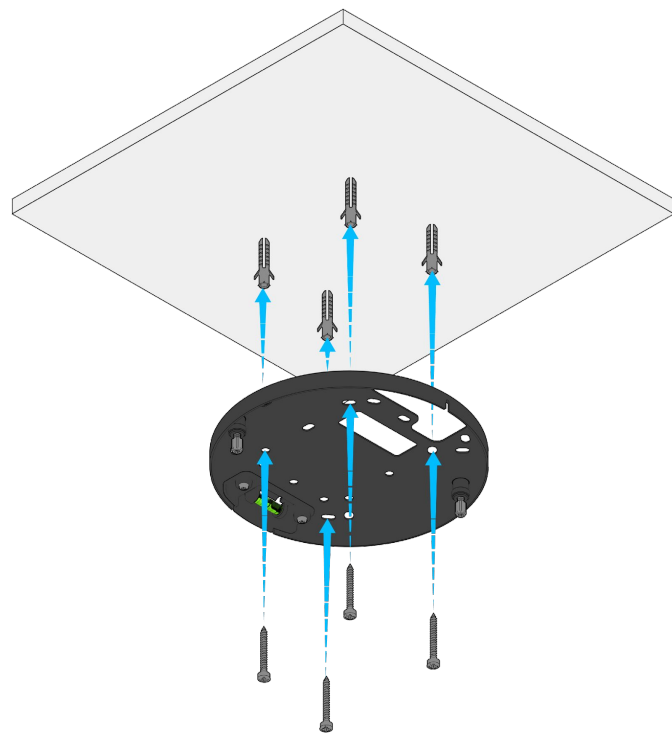

Installation

Mounting 4/6

Retrieve the camera.

Loosen the screw on the cable latch, using the T10 Torx Security Screwdriver.

Open the cable latch.

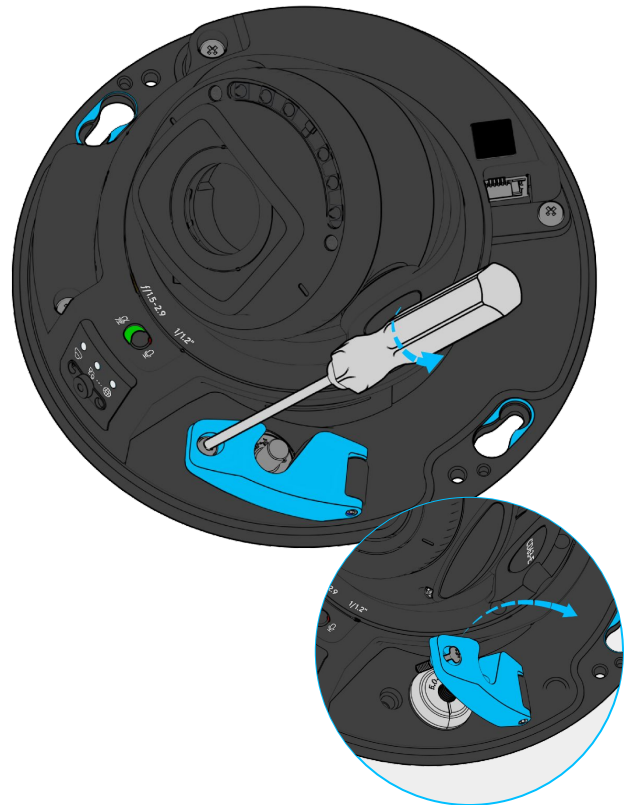

Remove the cable gland and set it aside.

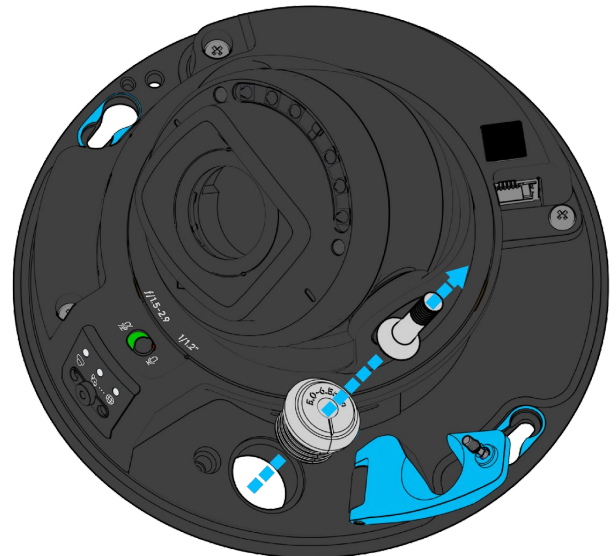

Installation

Mounting 5/6

Select the appropriate size cable gland and wrap it around the Ethernet cable.

Press the cable gland into cable gland hole. Lead Ethernet cable through the cable cavity and latch. Connect the Ethernet cable to the camera.

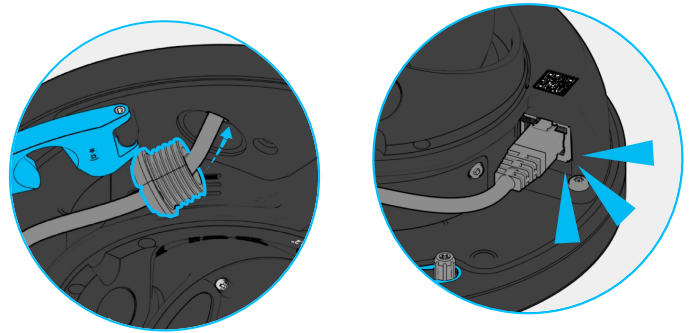

Make sure that there are no gaps or openings.

In case of cable slack, press the excess Ethernet cable into the cable gland.

Ensure that the cable gland is firmly in place with no gaps or unevenness.

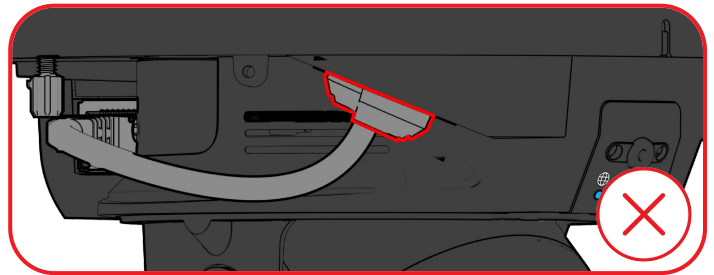
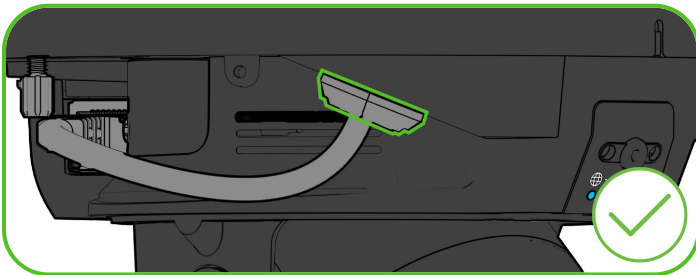

Ensure the latch is fully down and closed before tightening the security screw.

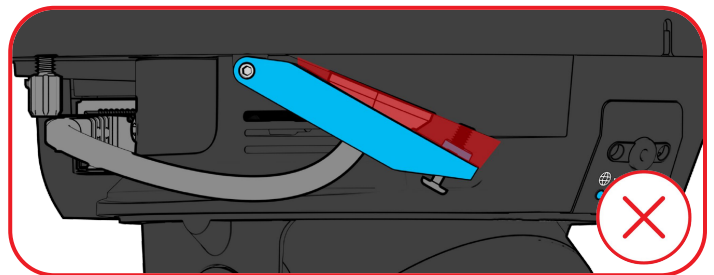
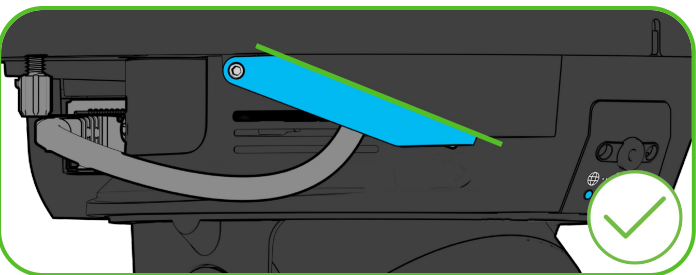

Installation

Mounting 6/6

Align the blue holes to the thumbscrews and rotate the camera clockwise.

Tighten the thumbscrews using the T10 Security Screwdriver to secure.

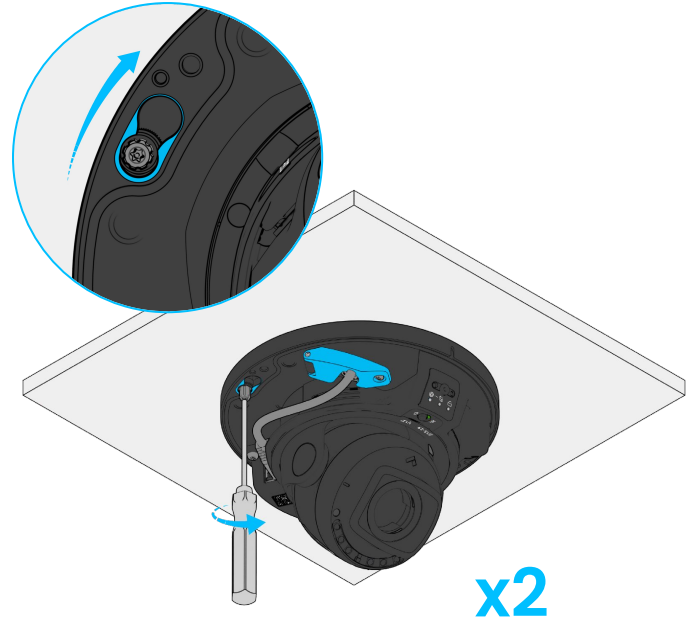

Close the latch and use the provided T10 Security Screwdriver to secure and seal the Ethernet cable.

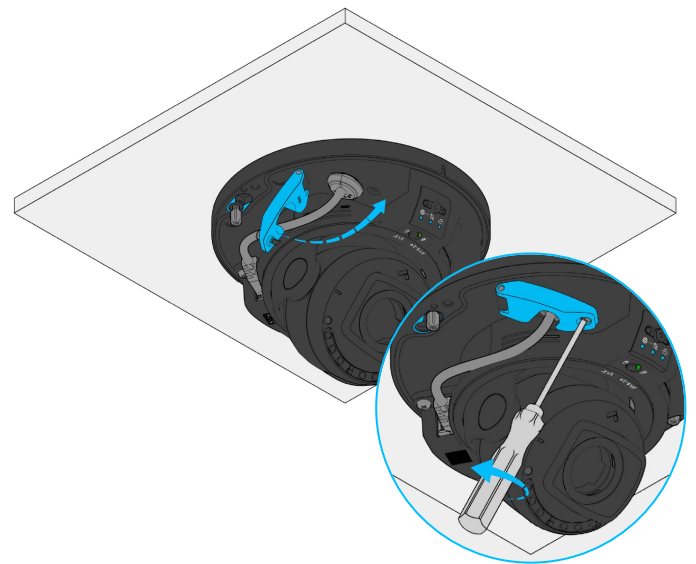

Scan QR code to register on Verkada Command. Refer to Connect Device section to continue.

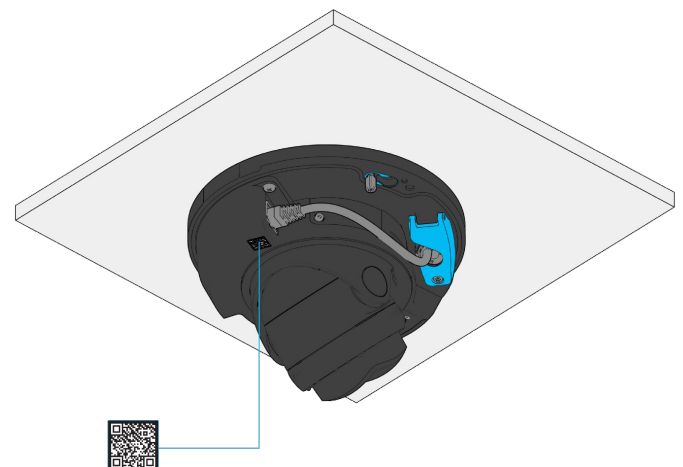

Installation

Adjust Camera Angle

Adjust the camera to the desired viewing angle and rotation.

The lines on the lens rubber indicate landscape image orientation.

View the camera feed through Command to get an accurate idea of orientation and the field of view.

Note: Image can also be rotated 90°, 180°, 270° in Command.

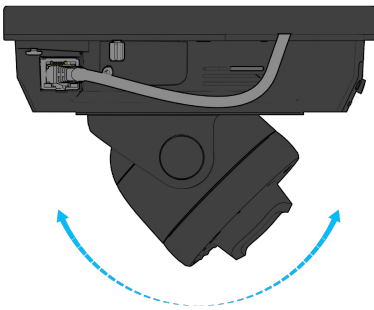
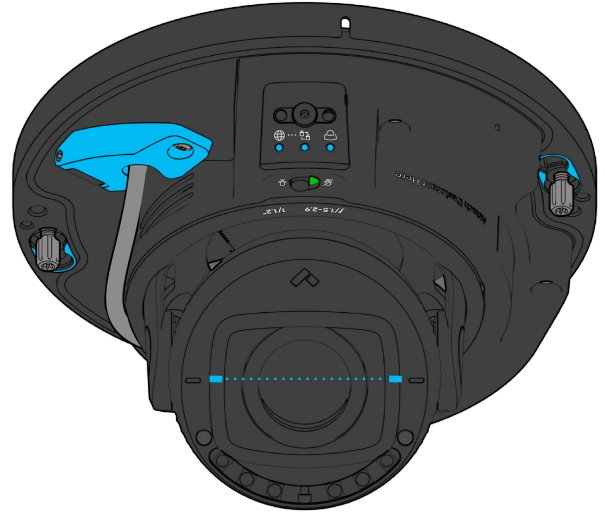

60°

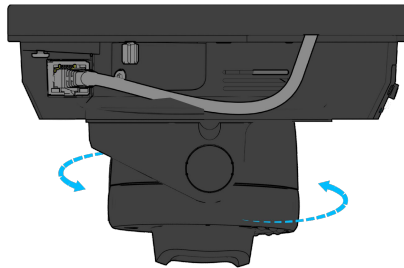

360°

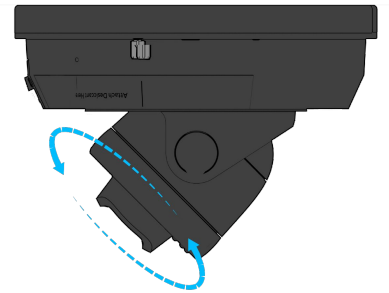

350°



Installation

Desiccant

Open and remove the desiccant pack from its outer pouch.

Peel the backing from the double-sided tape on the desiccant pack.

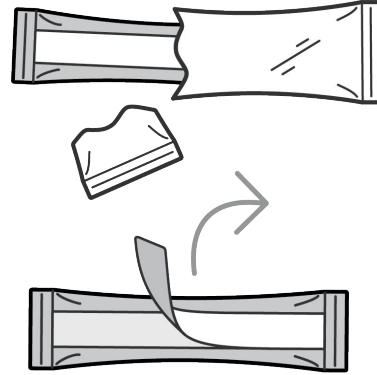

Place the pack directly on to the "Attach desiccant here" text on the inner shell

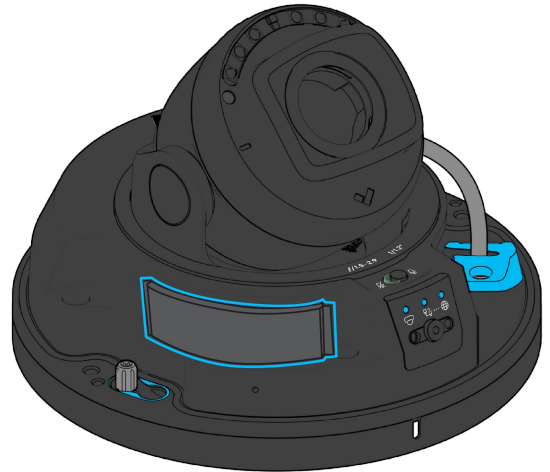

Installation

Secure

Align the top cover Security Torx Screw positions to the corresponding holes on the camera base and hold it in place.

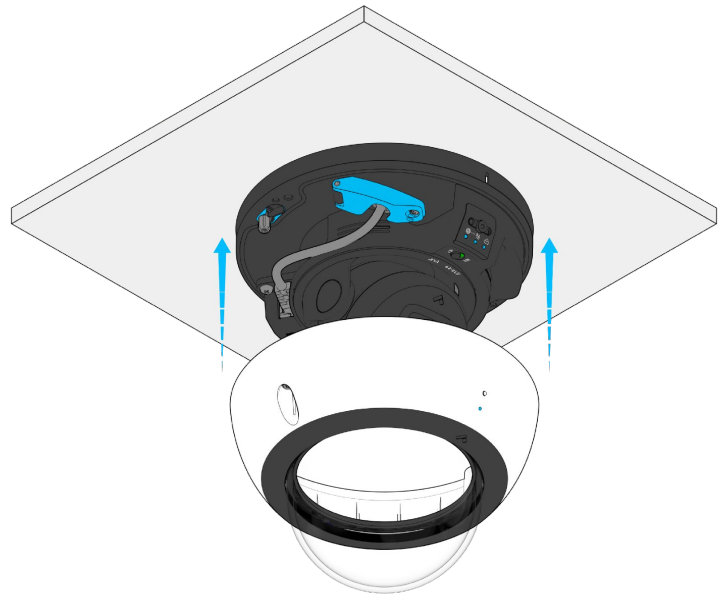

To secure, tighten the two T10 Torx Security Screws.

Remove the plastic film from the clear bubble.

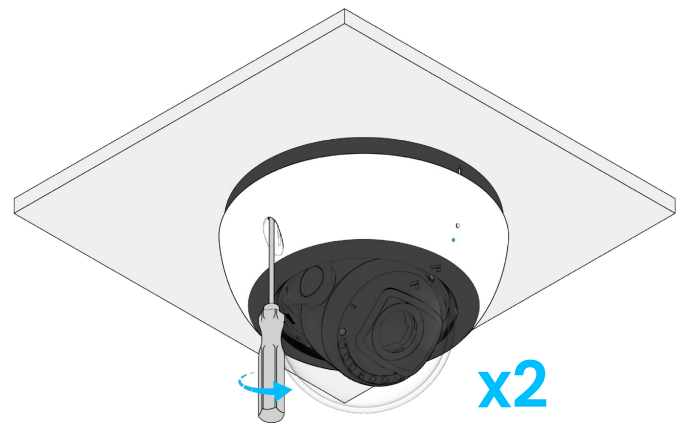

Appendix

Compliance

<p>Caution</p>	<ol style="list-style-type: none"> 1. Maintenance and repair work must always be carried out by qualified technical personnel. Disconnect power from the unit when performing a maintenance task. 2. Wiring methods used for the connection of the equipment to earth shall be in accordance with the National Electrical Code, ANSI/NFPA 70, and the Canadian Electrical Code, Part 1, CSA C22.1. 3. The product must be installed and protected in a location that is not easily accessible and is away from impacts or heavy vibration. 4. The device is only to be connected to PoE networks without routing to outside plants. 5. If powered by a power adapter, the adapter should be properly grounded. 6. Please contact certified dealers for power adapters.
<p>FCC Compliance</p>	<p>This device complies with Part 15 of the FCC Rules. Operation is subject to the following two conditions: (1) This device may not cause harmful interference, and (2) this device must accept any interference received, including interference that may cause undesired operation.</p> <p>This equipment has been tested and found to comply with the limits for a Class B digital device, pursuant to Part 15 of the FCC Rules. These limits are designed to provide reasonable protection against harmful interference in a residential installation. This equipment generates, uses and can radiate radio frequency energy and, if not installed and used in accordance with the instructions, may cause harmful interference to radio communications. However, there is no guarantee that interference will not occur in a particular installation. If this equipment does cause harmful interference to radio or television reception, which can be determined by turning the equipment off and on, the user is encouraged to try to correct the interference by one of the following measures:</p> <ul style="list-style-type: none"> -Reorient or relocate the receiving antenna. -Increase the separation between the equipment and receiver. -Connect the equipment into an outlet on a circuit different from that to which the receiver is connected. -Consult the dealer or an experienced radio/TV technician for help.
<p>ISED Compliance</p>	<p>This device complies with ISED's licence-exempt RSSs. Operation is subject to the following two conditions: (1) This device may not cause harmful interference, and (2) this device must accept any interference received, including interference that may cause undesired operation.</p> <p>Le présent appareil est conforme aux CNR d'ISED applicables aux appareils radio exempts de licence. L'exploitation est autorisée aux deux conditions suivantes : (1) le dispositif ne doit pas produire de brouillage préjudiciable, et (2) ce dispositif doit accepter tout brouillage reçu, y compris un brouillage susceptible de provoquer un fonctionnement indésirable.</p>



Appendix

Support

Thank you for purchasing this Verkada product. If for any reason you're experiencing issues or need assistance, please contact our 24/7 Technical Support Team immediately.

Sincerely,
The Verkada Team
verkada.com/support

