

QSFP-40G-BD-RX-AO

Cisco® Compatible 40GBase-BX QSFP+ Monitor (MMF, 832nm/918nm, LC, Rx only)

Features

- Compliant to the 40GbE XLPPI electrical specification per IEEE 802.3ba-2010
- Compliant to QSFP+ SFF-8436 Specifications
- Aggregate bandwidth of >40Gbps
- Duplex LC connector only receiver
- Operates at 10.3125 Gbps per electrical channel with 64b/66b encoded data
- QSFP MSA compliant
- Single +3.3V power supply operating
- Temperature range 0°C to 70°C
- Utilizes a standard LC duplex fiber cable allowing reuse of existing cable infrastructure
- RoHS Compliant Part

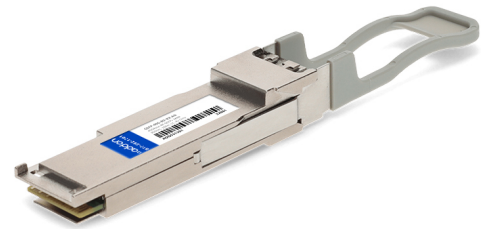

Applications:

- Network Monitoring Applications

Product Description

This Cisco® QSFP-40G-BD-RX compatible QSFP+ module is ideal for network monitoring applications, accepting both the 832nm/918nm wavelengths of 40G “bidi” applications. It is guaranteed to be 100% compatible with the equivalent Cisco® module. This easy to install, hot swappable monitor has been programmed, uniquely serialized and data-traffic and application tested to ensure that it will initialize and perform identically. We stand behind the quality of our products and proudly offer a limited lifetime warranty.

AddOn’s QSFP+ transceivers are RoHS compliant and lead-free.

Regulatory Compliance

- ESD to the Electrical PINs: compatible with MIL-STD-883E Method 3015.4
- ESD to the LC Receptacle: compatible with IEC 61000-4-3
- EMI/EMC compatible with FCC Part 15 Subpart B Rules, EN55022:2010
- Laser Eye Safety compatible with FDA 21CFR, EN60950-1& EN (IEC) 60825-1,2
- RoHS compliant with EU RoHS 2.0 directive 2015/863/EU

Absolute Maximum Ratings

Parameter	Symbol	Min.	Typ.	Max.	Unit
Supply Voltage	VccT, R	-0.5		4	V
Storage Temperature	Ts	-40		+85	°C
Case Operating Temperature	Tc	0		+70	°C
Relative Humidity	RH	0		85	%

Electrical Characteristics

Parameter	Symbol	Min.	Typ.	Max.	Unit	Notes
Supply Voltage	VccT, R	+3.13	3.3	+3.47	V	
Supply Current	Icc		0.75	1.0	A	
Power Consumption	PD		2.5	3.5	W	
Control I/O Voltage-High	VIH	2.0		Vcc	V	
Control I/O Voltage-Low	VIL	0		0.7	V	
Inter-Channel Skew	TSK			150	Ps	
RESETL Duration			10		Us	
RESETL De-assert time				100	ms	
Power On Time				100	ms	
Receiver						
Single Ended Output Voltage Tolerance		0.3		4	V	
Rx Output Diff Voltage	Vo		600	800	mV	
Rx Output Rise and Fall Voltage	Tr/Tf			35	ps	1
Total Jitter	TJ			0.7	UI	
Deterministic Jitter	DJ			0.42	UI	

Notes:

1. 20~80%

Optical Characteristics (TOP = 0 to 70 °C, VCC = 3.0 to 3.6 Volts)

Parameter	Symbol	Min.	Typ.	Max.	Unit	Notes
Receiver						
Optical Center Wavelength CH1	λ	882	900	918	nm	
Optical Center Wavelength CH2	λ	832	850	868	nm	
Receiver Sensitivity per Channel	R		-11		dBm	
Maximum Input Power	P _{MAX}	+0.5			dBm	
Receiver Reflectance	R _{rx}			-12	dB	
LOS De-Assert	LOSD			-14	dBm	
LOS Assert	LOSA	-30			dBm	
LOS Hysteresis	LOSH	0.5			dB	

Notes:

1. 12dB Reflection

Electrical Pin-out Details

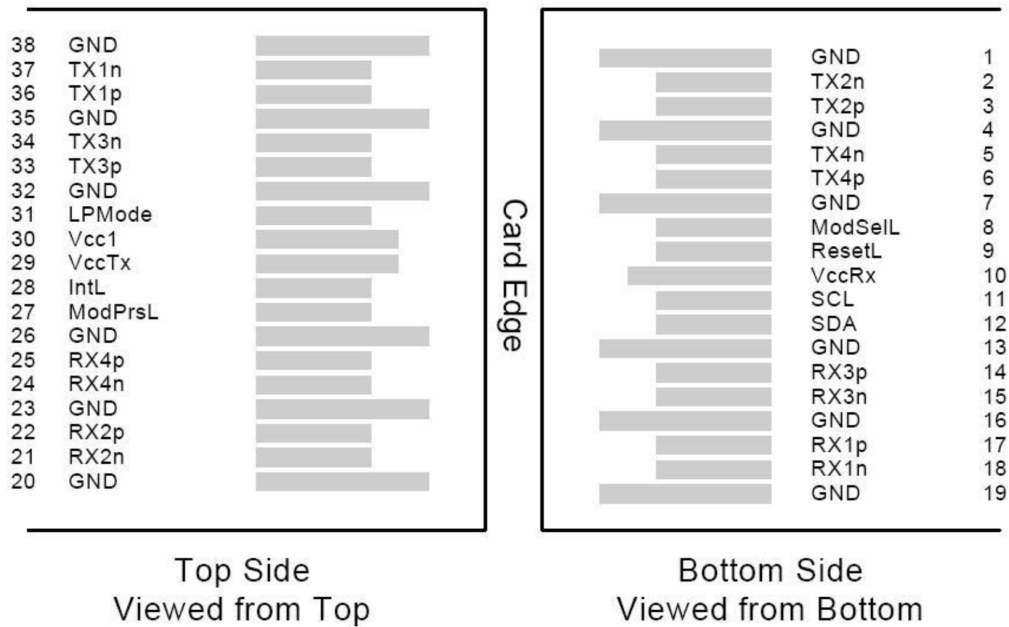

Pin Descriptions

Pin	Logic	Symbol	Name/Descriptions	Ref.
1		GND	Module Ground	1
2	CML-I	Tx2-	Transmitter inverted data input	
3	CML-I	Tx2+	Transmitter non-inverted data input	
4		GND	Module Ground	1
5	CML-I	Tx4-	Transmitter inverted data input	
6	CML-I	Tx4+	Transmitter non-inverted data input	
7		GND	Module Ground	1
8	LVTTTL-I	MODSEIL	Module Select	2
9	LVTTTL-I	ResetL	Module Reset	2
10		VCCR _x	+3.3v Receiver Power Supply	
11	LVC _{MOS} -I	SCL	2-wire Serial interface clock	2
12	LVC _{MOS} -I/O	SDA	2-wire Serial interface data	2
13		GND	Module Ground	1
14	CML-O	RX3+	Receiver non-inverted data output	
15	CML-O	RX3-	Receiver inverted data output	
16		GND	Module Ground	1
17	CML-O	RX1+	Receiver non-inverted data output	
18	CML-O	RX1-	Receiver inverted data output	
19		GND	Module Ground	1
20		GND	Module Ground	1
21	CML-O	RX2-	Receiver inverted data output	
22	CML-O	RX2+	Receiver non-inverted data output	
23		GND	Module Ground	1
24	CML-O	RX4-	Receiver inverted data output	
25	CML-O	RX4+	Receiver non-inverted data output	
26		GND	Module Ground	1
27	LVTTTL-O	ModPrsL	Module Present, internal pulled down to GND	
28	LVTTTL-O	IntL	Interrupt output, should be pulled up on host board	2
29		VCCT _x	+3.3v Transmitter Power Supply	
30		VCC1	+3.3v Power Supply	
31	LVTTTL-I	LPM _o de	Low Power Mode	2
32		GND	Module Ground	1
33	CML-I	Tx3+	Transmitter non-inverted data input	
34	CML-I	Tx3-	Transmitter inverted data input	
35		GND	Module Ground	1
36	CML-I	Tx1+	Transmitter non-inverted data input	
37	CML-I	Tx1-	Transmitter inverted data input	
38		GND	Module Ground	1

Notes:

1. GND is the symbol for single and supply(power) common for QSFP modules, All are common within the QSFP module and all module voltages are referenced to this potential otherwise noted. Connect these directly to the host board signal common ground plane. Laser output disabled on TDIS >2.0V or open, enabled on TDIS <0.8V.
2. VccRx, Vcc1 and VccTx are the receiver and transmitter power suppliers and shall be applied concurrently.

Recommended Circuit

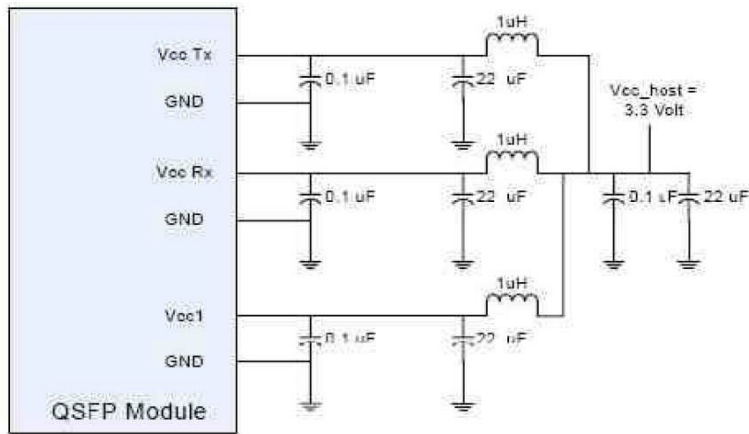

Mechanical Specifications

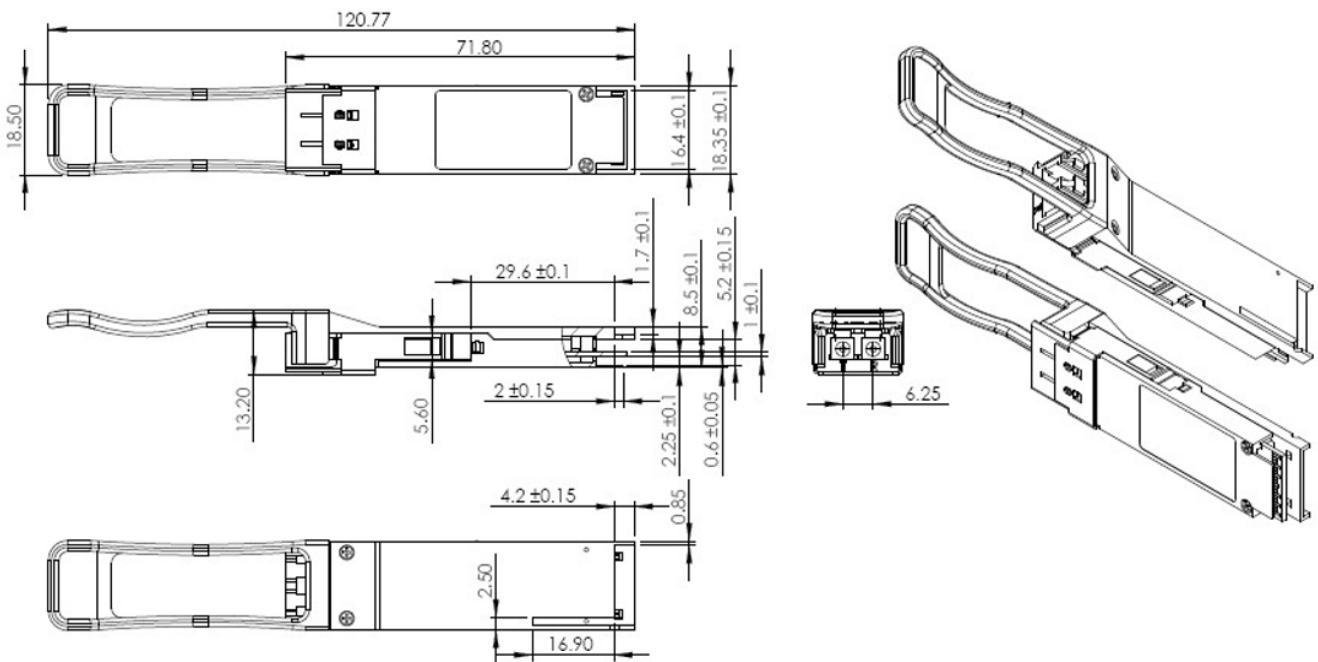

About AddOn Networks

In 1999, AddOn Networks entered the market with a single product. Our founders fulfilled a severe shortage for compatible, cost-effective optical transceivers that compete at the same performance levels as leading OEM manufacturers. Adhering to the idea of redefining service and product quality not previously had in the fiber optic networking industry, AddOn invested resources in solution design, production, fulfillment, and global support.

Combining one of the most extensive and stringent testing processes in the industry, an exceptional free tech support center, and a consistent roll-out of innovative technologies, AddOn has continually set industry standards of quality and reliability throughout its history.

Reliability is the cornerstone of any optical fiber network and is engrained in AddOn's DNA. It has played a key role in nurturing the long-term relationships developed over the years with customers. AddOn remains committed to exceeding industry standards with certifications from ranging from NEBS Level 3 to ISO 9001:2005 with every new development while maintaining the signature reliability of its products.

U.S. Headquarters

Email: sales@addonnetworks.com

Telephone: +1 877.292.1701

Fax: 949.266.9273

Europe Headquarters

Email: salesupportemea@addonnetworks.com

Telephone: +44 1285 842070