

02310YTE-AO

Huawei® 02310YTE (CFP-100G-ER4) Compatible TAA Compliant 100GBase-ER4 CFP Transceiver (SMF, 1310nm, 40km, LC, DOM)

Features

- CFP MSA 1.4 Compliance
- Duplex LC Connector
- Commercial Temperature 0 to 70 Celsius
- Single-mode Fiber
- Hot Pluggable
- Excellent ESD Protection
- Metal with Lower EMI
- RoHS Compliant and Lead Free



Applications

- 100GBase Ethernet
- Access and Enterprise

Product Description

This Huawei® 02310YTE compatible CFP transceiver provides 100GBase-ER4 throughput up to 40km over single-mode fiber (SMF) using a wavelength of 1310nm via an LC connector. It is guaranteed to be 100% compatible with the equivalent Huawei® transceiver. This easy to install, hot swappable transceiver has been programmed, uniquely serialized and data-traffic and application tested to ensure that it will initialize and perform identically. Digital optical monitoring (DOM) support is also present to allow access to real-time operating parameters. This transceiver is Trade Agreements Act (TAA) compliant. We stand behind the quality of our products and proudly offer a limited lifetime warranty.

AddOn's transceivers are RoHS compliant and lead-free.

TAA refers to the Trade Agreements Act (19 U.S.C. & 2501-2581), which is intended to foster fair and open international trade. TAA requires that the U.S. Government may acquire only "U.S. – made or designated country end products."



Regulatory Compliance

Feature	Standard	Performance
Electrostatic Discharge (ESD) to the Electrical Pins	MIL-STD-883E Method 3015.7	Class 1(>500 V) Isolation with the case
Electromagnetic Interference (EMI)	FCC Part 15 Class B	Compatible with standards
Laser Eye Safety	FDA 21CFR 1040.10 and 1040.11 EN60950, EN (IEC) 60825-1,2	Compatible with Class I laser product. Compatible with T μ V standards
Component Recognition	UL and CUL	UL file E317337
Green Products	RoHS	RoHS6

Absolute Maximum Ratings

Parameter	Symbol	Min.	Max.	Unit
Storage Temperature	T _s	-40	+85	°C
Case Temperature	T _c	-5	+75	°C
Supply Voltage	V _{cc}	-0.5	3.6	V
Operating Relative Humidity	RH	5	85	%

Recommended Operating Conditions

Parameter	Symbol	Min.	Typ.	Max.	Unit
Operating Case Temperature	T _c	0		+70	°C
Power Supply Voltage	V _{CC}	3.2	3.3	3.4	V
Power Supply Current	I _{CC}		2700		mA

Electrical Characteristics

Parameter	Symbol	Min.	Typ.	Max.	Unit	Notes
Transmitter						
Input Amplitude (Differential)	V _{in}			1050	mV _{pp}	AC coupled inputs
Input Impedance (Differential)	Z _{in}	80	100	120	Ohms	R _{in} > 100 kohms @ DC
Receiver						
Output Amplitude (Differential)	V _{out}	360		770	mV _{pp}	AC coupled outputs
Output Impedance (Differential)	Z _{out}	80	100	120	Ohms	
Output Rise/Fall Time	T _r /t _f	24			Ps	20%~80%

Optical Characteristics

Parameter	Symbol	Min.	Typ.	Max.	Unit
Transmitter					
Signaling Speed Per Lane	BR_{AVE}		27.95		Gbps
Data Rate Variation		-20		20	Ppm
Lane_0 Center Wavelength	λ_{C0}	1294.53	1295.56	1296.59	Nm
Lane_1 Center Wavelength	λ_{C1}	1299.02	1300.05	1301.09	Nm
Lane_2 Center Wavelength	λ_{C2}	1303.54	1304.58	1305.63	nm
Lane_3 Center Wavelength	λ_{C3}	1308.09	1309.14	1310.19	Nm
Total Average Output Power (Note 5&6)	P_{O1}			8.9	dBm
Average Launch Power per Lane (Note 6)	P_{each1}	-2.7		2.9	dBm
Maximum Channel Power Difference				3.6	dB
Side Mode Suppression Ratio	SMSR	30			dB
Optical Return Loss Tolerance				20	dB
Extinction Ratio (Note 6)	ER_1	8			dB
Transmitter Eye Mask Definition {X1, X2, X3, Y1, Y2, Y3} (Note 6)		G.959.1 Compliant			
TX Disable Assert Time	T_{off}			100	Us
Receiver					
Signaling Speed Per Lane	BR_{AVE}		27.95		Gbps
Data Rate Variation		-20		20	Ppm
Lane_0 Center Wavelength	λ_{C0}	1294.53	1295.56	1296.69	Nm
Lane_1 Center Wavelength	λ_{C1}	1299.02	1300.05	1301.09	Nm
Lane_2 Center Wavelength	λ_{C2}	1303.54	1304.58	1305.63	Nm
Lane_3 Center Wavelength	λ_{C3}	1308.09	1309.14	1310.19	Nm
Average Receive Power for Each Lane (Note 9)	R_{pow1}	-20.7		4.5	dBm
Maximum Mean Total Input Power				10.5	dBm
Equivalent Sensitivity per Lane (Note 11)	P_{min1}			-23.2	dBm
Maximum Channel Power Difference				4.5	dB

100GBase-ER4 Operation

Parameter	Symbol	Min.	Typ.	Max.	Unit
Transmitter					
Signaling Speed Per Lane	BR_{AVE}		25.78		Gbps
Data Rate Variation		-100		100	Ppm
Lane_0 Center Wavelength	λ_{C0}	1294.53	1295.56	1296.59	Nm
Lane_1 Center Wavelength	λ_{C1}	1299.02	1300.05	1301.09	Nm
Lane_2 Center Wavelength	λ_{C2}	1303.54	1304.58	1305.63	nm
Lane_3 Center Wavelength	λ_{C3}	1308.09	1309.14	1310.19	Nm
Total Average Output Power (Note 5&6)	P_{O1}			8.9	dBm
Average Launch Power per Lane (Note 6)	P_{each2}	-2.9		2.9	dBm
Optical Modulation Amplitude	OMA	0.1		4.5	dB
Side Mode Suppression Ratio	SMSR	30			dB
Optical Return Loss Tolerance				20	dB
Extinction Ratio (Note 6)	ER_2	8			dB
Transmitter Eye Mask Definition {X1, X2, X3, Y1, Y2, Y3} (Note 8)		IEEE802.3ba-2010 Compliant			
TX Disable Assert Time	T_{off}			100	Us
Receiver					
Signaling Speed Per Lane	BR_{AVE}		25.78		Gbps
Data Rate Variation		-100		100	Ppm
Lane_0 Center Wavelength	λ_{C0}	1294.53	1295.56	1296.59	Nm
Lane_1 Center Wavelength	λ_{C1}	1299.02	1300.05	1301.09	Nm
Lane_2 Center Wavelength	λ_{C2}	1303.54	1304.58	1305.63	Nm
Lane_3 Center Wavelength	λ_{C3}	1308.09	1309.14	1310.19	Nm
Average Receive Power for Each Lane (Note 9)	R_{pow2}	-20.9		4.5	dBm
Receiver Power (OMA)	P_{ovi}			4.5	dBm
Difference in Receive Power Between Any Two Lanes (Average and OMA)				4.5	dB
Receive Sensitivity (OMA) per Lane (Note 12)	P_{min2}			-21.4	dBm
Stressed Sensitivity (OMA) per lane	SRS			-17.9	dBm

Notes:

1. Output is coupled into a 9/125 μ m single-mode fiber.
2. Filtered, measured with a PRBS $2^{31}-1$ test pattern @ 27.95Gbps

3. High speed I/O, internally AC coupled
4. Filtered, measured with a PRBS $2^{31}-1$ test pattern @ 25.78Gbps
5. CFP transceiver works in OTU4 4I1-9C1F mode
6. CFP transceiver works in 100GBase-ER4 mode
7. Measured at BER less than $1E-12$, with a $2^{31}-1$ PRBS@ 27.95Gbps (W/ FEC)
8. Measured at BER less than $1E-12$, with a $2^{31}-1$ PRBS@ 25.78Gbps

Functional Description of Transceiver

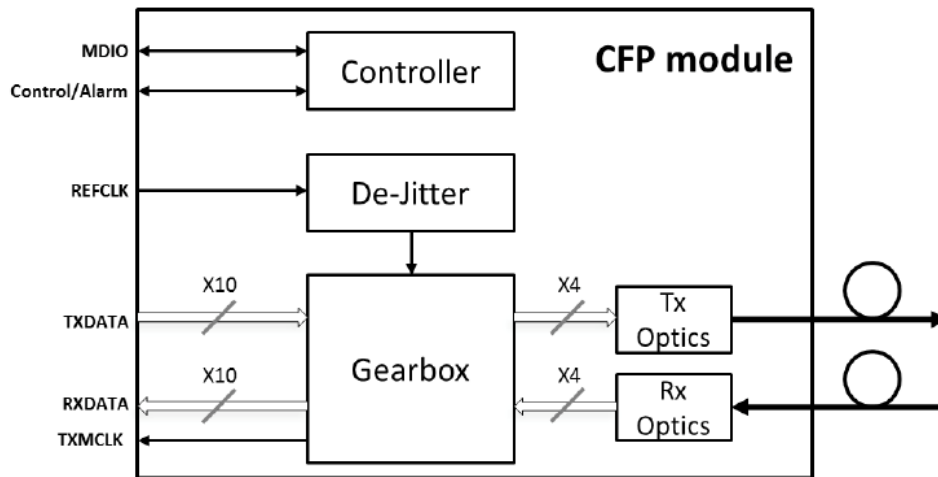

Pin Descriptions

Part A: Bottom Row Pin Function Definition

Pin	Symbol	Type	I/O	Description
1	3.3V_GND	GND		3.3V Module Supply Voltage Return Ground, can be separate or tied together with Signal Ground
2	3.3V_GND	GND		
3	3.3V_GND	GND		
4	3.3V_GND	GND		
5	3.3V_GND	GND		
6	3.3V	VCC		3.3V Module Supply
7	3.3V	VCC		
8	3.3V	VCC		
9	3.3V	VCC		
10	3.3V	VCC		
11	3.3V	VCC		
12	3.3V	VCC		
13	3.3V	VCC		
14	3.3V	VCC		
15	3.3V	VCC		
16	3.3V_GND	GND		
17	3.3V_GND	GND		
18	3.3V_GND	GND		
19	3.3V_GND	GND		
20	3.3V_GND	GND		
21	NC		I/O	Do not use
22	NC		I/O	Do not use
23	GND	GND		
24	(TX_MCLKn)	CML	O	Do not use
25	(TX_MCLKp)	CML	O	Do not use
26	GND	GND		
27	NC		I/O	Do not use
28	NC		I/O	Do not use
29	NC		I/O	Do not use
30	PRG_CTL1	LVC MOS w/PU	I	Programmable Control 1 set via MDIO, MSA default: TRXIC_RSTn-TX & RX IC reset. "0"=reset, "1" or NC = enabled or not used
31	PRG_CTL2	LVC MOS w/PU	I	Programmable Control 2 set via MDIO, MSA default: Hardware power Interlock LSB, "00" = <8W, "01" = <16W, "10" < 24W, "11" or NC = >24W or not used
32	PRG_CTL3			Programmable Control 3 set via MDIO, MSA default: Hardware power Interlock MSB, "00" = <8W, "01" = <16W, "10" < 24W, "11" or NC = >24W or not used
33	PRG_ALARM1	LVC MOS	O	Programmable Alarm 1 set via MDIO, Reflex default: HIPWR_ON, Module power on indicator. "1" = Module high power up completed, "0" = Module not high powered up
34	PRG_ALARM2	LVC MOS	O	Programmable Alarm 2 set via MDIO, Reflex default: MOD_READY, module initialization complete, "1" = complete, "0" = not complete

35	PRG_ALARM3	LVC MOS	O	Programmable Alarm 3 set via MDIO, Reflex default: MOD_FAULT, module fault detected, "1" = fault, "0" = no fault
36	TX_DIS	LVC MOS w/PU	I	Transmitter Disable for all channels, "1" or NC = transmitter disabled, "0" = transmitter enabled
37	MOD_LOPW	LVC MOS w/PU	I	Module low power mode. "1" or NC = module in low power (safe) mode, "0" = power-on enabled
38	MOD_ABS	GND	O	Module Absent. "1" or NC = Module absent, "0" = module present. Pull-up resistor on Host
39	MOD_RSTn	LVC MOS w/PD	I	Module Reset. "0" = reset the module, "1" or NC = module enabled, Pull Down resistor in module
40	RX_LOS	LVC MOS	O	Receiver loss of optical signal on any channel, "1" = loss of signal, "0" = normal condition
41	GLB_ALRMn	LVC MOS	O	Global Alarm. "0" = alarm condition in any MDIO alarm register, "1" = no alarm
42	PRTADR4	1.2V CMOS	I	MDIO port address bit 4
43	PRTADR3	1.2V CMOS	I	MDIO port address bit 3
44	PRTADR2	1.2V CMOS	I	MDIO port address bit 2
45	PRTADR1	1.2V CMOS	I	MDIO port address bit 1
46	PRTADR0	1.2V CMOS	I	MDIO port address bit 0
47	MDIO	1.2V CMOS	I/O	Management Data I/O bi-directional data (electrical specs as per 802.3ae)
48	MDO	1.2V CMOS	I	Management data clock (electrical specs as per 802.3ae)
49	GND	GND		
50	NC		I/O	Do not use
51	NC		I/O	Do not use
52	GND	GND		
53	NC		I/O	Do not use
54	NC		I/O	Do not use
55	3.3V_GND	GND		3.3V Module Supply Voltage Return Ground, can be separate or tied together with Signal Ground
56	3.3V_GND	GND		
57	3.3V_GND	GND		
58	3.3V_GND	GND		
59	3.3V_GND	GND		
60	3.3V	VCC		3.3V Module Supply
61	3.3V	VCC		
62	3.3V	VCC		
63	3.3V	VCC		
64	3.3V	VCC		
65	3.3V	VCC		
66	3.3V	VCC		
67	3.3V	VCC		
68	3.3V	VCC		
69	3.3V	VCC		
70	3.3V_GND	GND		
71	3.3V_GND	GND		
72	3.3V_GND	GND		

73	3.3V_GND	GND		
74	3.3V_GND	GND		

Part B: Top Row Pin Function Definition

Pin	Symbol	Pin	Symbol	Pin	Symbol	Pin	Symbol	Pin	Symbol
148	GND	136	GND	124	GND	112	GND	100	RX7p
147	Not used	135	TX7n	123	TX3n	111	GND	99	GND
146	Not used	134	TX7p	122	TX3p	110	Not used	98	RX6n
145	GND	133	GND	121	GND	109	Not used	97	RX6p
144	Not used	132	TX6n	120	TX2n	108	GND	96	GND
143	Not used	131	TX6p	119	TX2p	107	RX9n	95	RX5n
142	GND	130	GND	118	GND	106	RX9p	94	RX5p
141	TX9n	129	TX5n	117	TX1n	105	GND	93	GND
140	TX9p	128	TX5p	116	TX1p	104	RX8n	92	RX4n
139	GND	127	GND	115	GND	103	RX8p	91	RX4p
138	TX8n	126	TX4n	114	TX0n	102	GND	90	GND
137	TX8p	125	TX4p	113	TX0p	101	RX7n	89	RX3n
88	RX3p	85	RX2p	82	RX1p	79	RX0p	76	Not used
87	GND	84	GND	81	GND	78	GND	75	GND
86	RX2n	83	RX1n	80	RX0n	77	Not used		

Mechanical Specifications

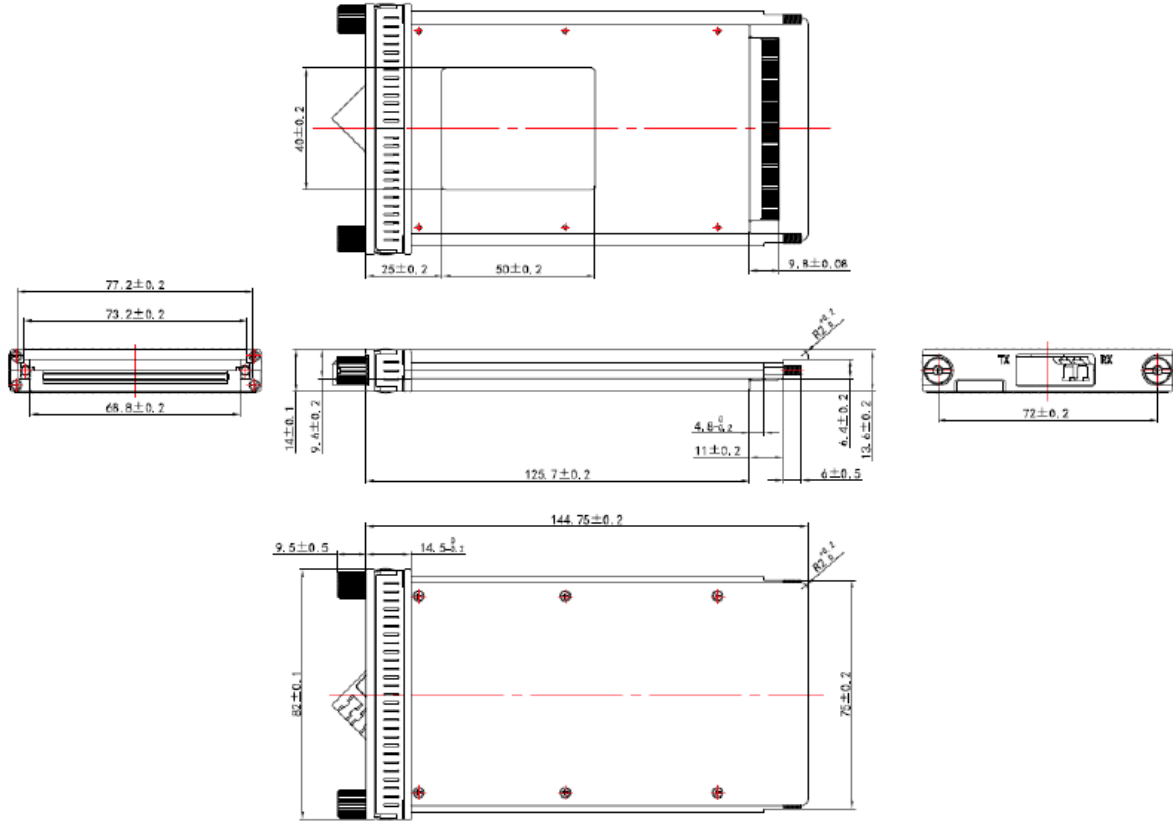

About AddOn Networks

In 1999, AddOn Networks entered the market with a single product. Our founders fulfilled a severe shortage for compatible, cost-effective optical transceivers that compete at the same performance levels as leading OEM manufacturers. Adhering to the idea of redefining service and product quality not previously had in the fiber optic networking industry, AddOn invested resources in solution design, production, fulfillment, and global support.

Combining one of the most extensive and stringent testing processes in the industry, an exceptional free tech support center, and a consistent roll-out of innovative technologies, AddOn has continually set industry standards of quality and reliability throughout its history.

Reliability is the cornerstone of any optical fiber network and is engrained in AddOn's DNA. It has played a key role in nurturing the long-term relationships developed over the years with customers. AddOn remains committed to exceeding industry standards with certifications from ranging from NEBS Level 3 to ISO 9001:2005 with every new development while maintaining the signature reliability of its products.

U.S. Headquarters

Email: sales@addonnetworks.com

Telephone: +1 877.292.1701

Fax: 949.266.9273

Europe Headquarters

Email: salesupportemea@addonnetworks.com

Telephone: +44 1285 842070