

EM-C7100 Start Here

IMPORTANT: Before using this product, make sure you read these instructions and the safety instructions in the online *User's Guide*.

Note: This printer is designed for use with Epson® ink cartridges only, not third-party ink. For important ink information, visit <http://epson.com/epsonink> (U.S.) or <http://epson.ca/epsonink> (Canada) or see your printer box.

Important Safety Instructions: When using telephone equipment, you should always follow basic safety precautions to reduce the risk of fire, electric shock, and personal injury, including the following:

- Do not use the Epson product near water.
- Always keep this guide handy.
- Avoid using a telephone during an electrical storm. There may be a remote risk of electric shock from lightning.
- Do not use a telephone to report a gas leak in the vicinity of the leak.

Caution: To reduce the risk of fire, use only a No. 26 AWG or larger telecommunication line cord.

1 Unpack

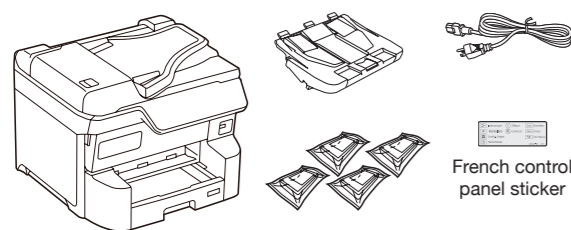

Warning: The product is heavy and should be lifted and moved by two people.

- 1 Remove all protective materials from the product and paper cassette.

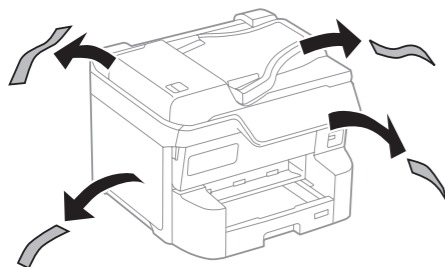

- 2 Open the front cover, remove all protective materials from inside the product, and close the front cover.

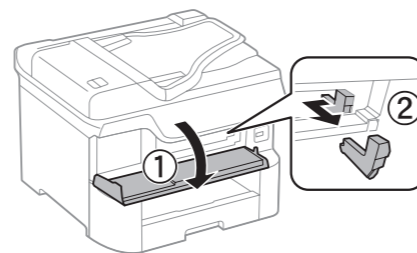

- 3 Insert the output tray, then lower it gently.

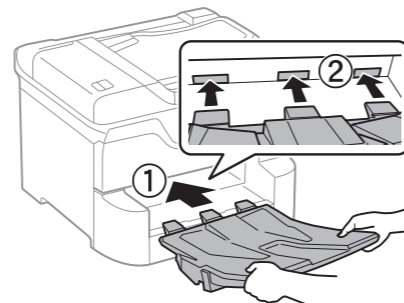

2 Turn on and configure

- 1 Connect the power cord to the back of the product and to an electrical outlet.

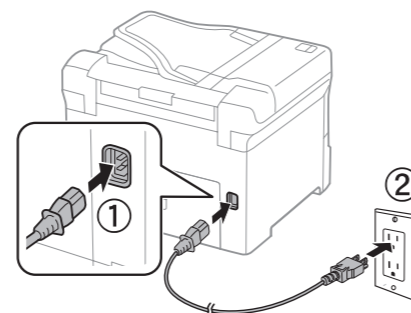

Caution: Do not connect to your computer yet.

- 2 Turn on the product.

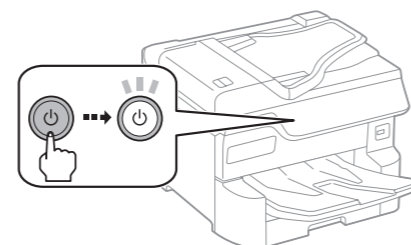

- 3 Select your language, date, and time using the arrow buttons and OK button.

Note: You can change these settings later using the product's control panel. For more information, see the online *User's Guide*.

3 Install ink cartridges

Caution: Keep the ink cartridges out of the reach of children and do not drink the ink.

Note: The included initial ink cartridges are designed for reliable printer setup and cannot be used as replacement ink cartridges or resold. After setup, the remaining ink is available for printing.

- 1 Open the front cover.

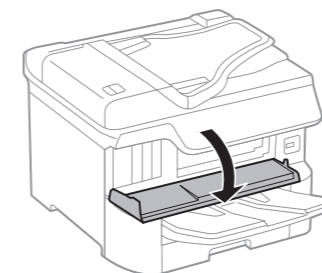

- 2 Unpack the ink cartridges.

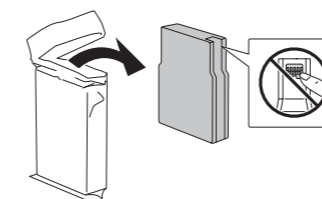

Caution: Do not remove any seals, or ink will leak. Do not touch the green chip on the cartridge.

- 3 Shake each ink cartridge horizontally about 15 times.

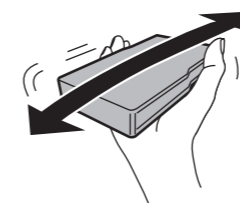

- 4 Insert the cartridge in the holder for each color. With the green chip facing up, insert each cartridge until it clicks.

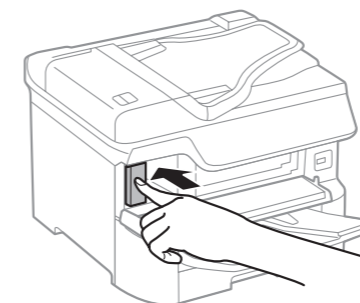

- 5 Close the front cover and press OK.

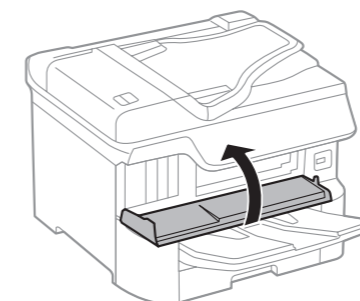

- 6 The printer starts charging the ink. Ink charging takes approximately 10 minutes. When you see a completion message on the printer's LCD screen, charging is complete.

Caution: Do not unplug or turn off the product or open the front cover while the product is charging or you'll waste ink.

4 Load paper

See the online *User's Guide* for information about loading capacity, available paper types and sizes, loading envelopes, and using the rear paper feed slot and the Automatic Document Feeder (ADF).

- 1 Make sure the product is done charging the ink, then pull out the paper cassette.

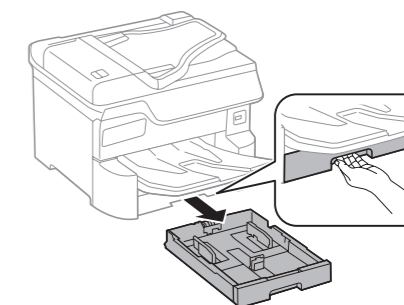

- 2 Slide the side edge guides all the way out and set the front edge guide to the paper size you are using.

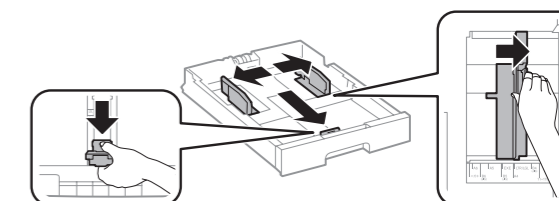

- 3 Insert paper with the glossy or printable side down, then slide the edge guides against the paper, but not too tightly.

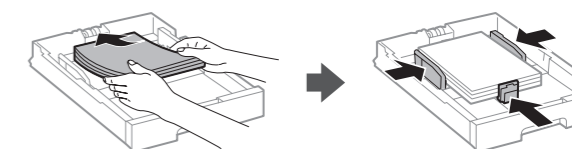

- 4 Keep the cassette flat as you insert it all the way.

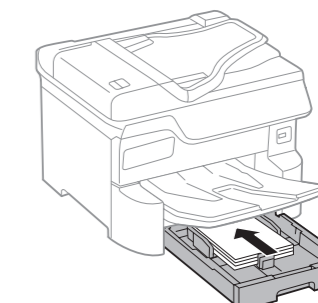

- 5 Select the paper settings on the product's control panel.



414527700

EPSON®



5 Connect the fax line

- 1 Connect a phone cord to a telephone wall jack and to the **LINE** port on our product. See the online *User's Guide* for more information.

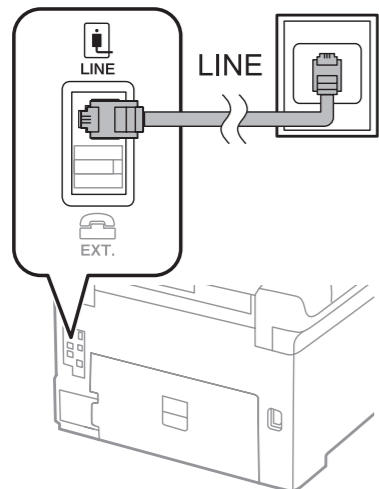

- 2 If prompted, press **Proceed** to set up the fax, or press **Close** to set it up later.

6 Install software

Note:

- An Internet connection is required to obtain the product software.
- To print from a Chromebook™, go to <http://epson.com/support/chromebookprint> (U.S.) or <http://epson.ca/support/chromebookprint> (Canada).

Firmware Update Notice: The printer is designed to work only with genuine Epson-branded ink cartridges. Other brands of ink cartridges and ink supplies are not compatible and, even if described as compatible, may not function properly or at all. Epson periodically provides firmware updates to address issues of security, performance, minor bug fixes and ensure the printer functions as designed. These updates may affect the functionality of third-party ink. Non-Epson branded or altered Epson cartridges that functioned prior to a firmware update may not continue to function.

Standard software package

- 1 Make sure the product is **NOT CONNECTED** to your computer.

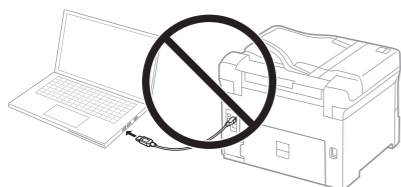

Windows®: If you see a Found New Hardware screen, click **Cancel** and disconnect the USB cable.

- 2 Download and run your product's software package:

<http://epson.com/support/emc7100> (U.S.)
<http://epson.ca/support/emc7100> (Canada)

- 3 Follow the instructions on the computer screen to run the setup program.

- 4 When you see the Select Your Connection screen, select one of the following and follow the on-screen instructions:

- **Wireless connection**

In most cases, the software installer automatically attempts to set up your wireless connection. If setup is unsuccessful, you may need to enter your network name (SSID) and password.

- **Direct USB connection**

Make sure you have a USB cable (not included).

- **Wired connection**

Make sure you have an Ethernet cable (not included).

PCL or PostScript driver

Download the software and see your online *User's Guide* for instructions.

<http://epson.com/support/emc7100> (U.S.)
<http://epson.ca/support/emc7100> (Canada)

Mobile and voice-activated printing

- Print directly from your Android™ (v4.4 or later) device*. Simply connect your printer and device to the same network and tap the menu icon to select the print option.
- Turn your mobile device into an intuitive, easy-to-use printing control center with Epson Smart Panel®. Download the app from your mobile device's app store.
- Print remotely with Epson Connect™. See your online *User's Guide* for instructions or learn more at <http://epson.com/connect> (U.S.) or <http://epson.ca/connect> (Canada).
- Use voice-activated assistants to print a variety of creative and everyday items from your Epson product. Simply add your product to an Epson Connect account, then link the account to a voice-activated assistant. See <http://epson.com/voice> (U.S.) or <http://epson.ca/voice> (Canada) for more information.

* May require the Epson Print Enabler or Mopria® Print Service app from Google Play™.

Any problems?

Network setup was unsuccessful.

- Print a network connection report to identify network problems and solutions. See your online *User's Guide* for instructions.
- Make sure you select the right network name (SSID).
- Restart your router (turn it off and then on), then try to connect to it again.
- If you see a firewall alert message, click **Unblock** or **Allow** to let setup continue.
- If your network has security enabled, make sure you enter your network password (WEP key or WPA passphrase) correctly. Be sure to enter your password in the correct case.

There are lines or incorrect colors in my printouts.

Run a nozzle check to see if there are any gaps in the printout. Then clean the print head, if necessary. See the online *User's Guide* for more information.

The product's screen is dark.

Make sure your product is turned on and press any button to wake it from sleep mode.

Setup is unable to find my product after connecting it with a USB cable.

Make sure your product is turned on and the USB cable is securely connected.

Any questions?

User's Guide

Windows: Click the icon on your desktop or Apps screen to access the online *User's Guide*.

Mac: Click the icon in Applications/Epson Software/Guide to access the online *User's Guide*.

If you don't have a User's Guide icon, go to the Epson website, as described below.

Technical Support

Visit <http://epson.com/support/emc7100> (U.S.) or <http://epson.ca/support/emc7100> (Canada) to download drivers, view videos, view manuals, get FAQs, or contact Epson.

Call (866) 212-8743, 7 a.m. to 4 p.m., Pacific Time, Monday through Friday. Days and hours of support are subject to change without notice.

Recycling

Epson offers a recycling program for end-of-life hardware and ink cartridges. Please go to <http://epson.com/recycle> (U.S.) or <http://epson.ca/recycle> (Canada) for information on how to return your products for proper disposal.

Need paper and ink?

Ensure brilliant results with Epson specialty and plain papers, engineered specifically for Epson printers. Find Epson papers and Epson Genuine Ink at <http://epson.com> (U.S. sales) or <http://epson.ca> (Canadian sales) and at Epson authorized resellers. Call 800-GO-EPSON (800-463-7766).



DESIGNED for
EXCELLENCE™

Epson printers, ink and specialty papers.

EM-C7100 replacement ink cartridges

Color	Standard-capacity	High-capacity	Extra High-capacity
Black	T13S1	T13U1	T13V1
Cyan	T13S2	T13U2	T13V2
Magenta	T13S3	T13U3	T13V3
Yellow	T13S4	T13U4	T13V4



EPSON, DURABrite, and Epson Smart Panel are registered trademarks, the EPSON logo is a registered logomark, and Epson Connect is a trademark of Seiko Epson Corporation.

Designed for Excellence is a trademark of Epson America, Inc.

Mac is a trademark of Apple Inc., registered in the U.S. and other countries.

The Mopria wordmark is a registered and/or unregistered trademark of Mopria Alliance, Inc. in the United States and other countries. Unauthorized use is strictly prohibited.

Android, Chromebook, and Google Play are trademarks of Google LLC.

Windows is a trademark of the Microsoft group of companies.

General Notice: Other product names used herein are for identification purposes only and may be trademarks of their respective owners. Epson disclaims any and all rights in those marks.

This information is subject to change without notice.

© 2024 Epson America, Inc., 6/24
Printed in XXXXX

CPD-64781