

HP Designjet T11XX (HD) MFP Assembly Instructions

EN

© 2008 Hewlett-Packard Company
Inkjet Commercial Division
Avenida Graells 501 - 08174
Sant Cugat del Valles
Barcelona - Spain

All rights reserved



Printed in Germany Imprimé en Allemagne Stampato in Germania



CK841-90011

Read these instructions carefully...

What you will need for this procedure

- Because the scanner is heavy, you may need three people to unpack it. When more than one person is needed, the symbol at the foot of this box is displayed.

- During the stand assembly you will see some reference to the following symbol labels which appear on some items, standing for left side, and right side.

L Left side
R Right side



x3

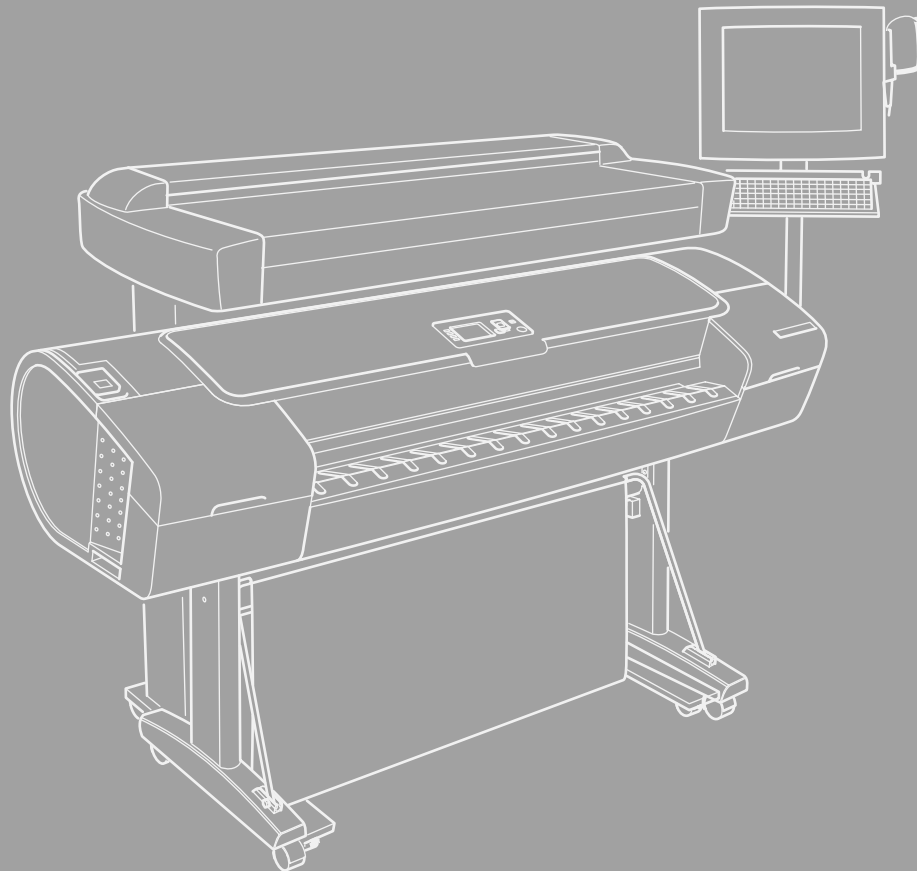

Your printer should already be assembled and working before starting this procedure. For instructions on how to assemble the printer, please refer to the assembly poster included with the printer.

Assembly poster

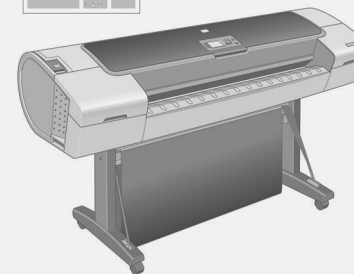

The touch screen assembly can be mounted on either the right or the left side of the stand.

Touch screen assembly

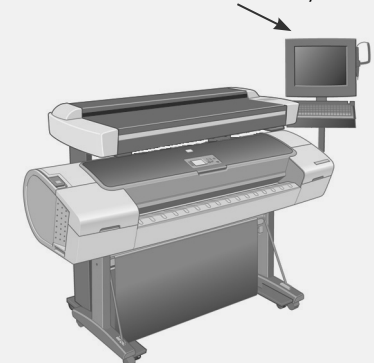

- Box
- 1. Calibration sheet
 - 2. Plastic dust cover
 - 3. Media guides (X2)
 - 4. A2 envelope
 - 5. Scanner
 - 6. System recovery DVD
- Box
- 7. Keyboard
 - 8. Rear Table
 - 9. Top bar with guide
 - 10. Left leg
 - 11. Assembly kit
 - 12. Maintenance kit
 - 13. Cable bundle
 - 14. Left foot
 - 15. Cross bar
 - 16. Right leg
 - 18. Bottom bar
 - 19. Right foot
 - 21. Touch Screen
 - 22. Monitor joint
 - 23. Keyboard table
 - 24. Touch screen pen
 - 25. Triangular bracket cover
 - 26. Straight bracket cover
 - 27. Touch screen bracket
 - 28. Assembly instructions

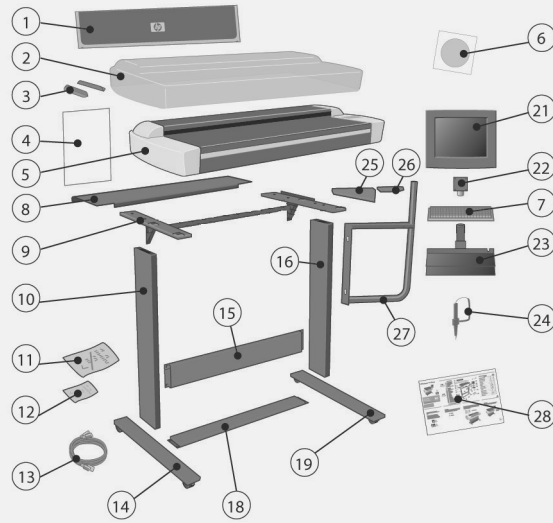

Assembly kit contents		Quantity supplied
Description		
Special screw for scanner		5
Screw M6x10 (Torx T30)		12
Screw M6x30 (Torx T30)		10
Screw M5x14		12
Starwasher 5mm		7
Earth cable		1
Torx Screw driver T25		1
T-handle Torx driver T30		1
Plastic strip		4
Large power cable clips		5
Small power cable clips		19
T-handle hex driver 2.5mm		1
Spanner for joint		1
Limit stop		2

1 Attach the lower bar to the two legs. Tighten the screws with the T-handle torx driver T30 found in the assembly kit.

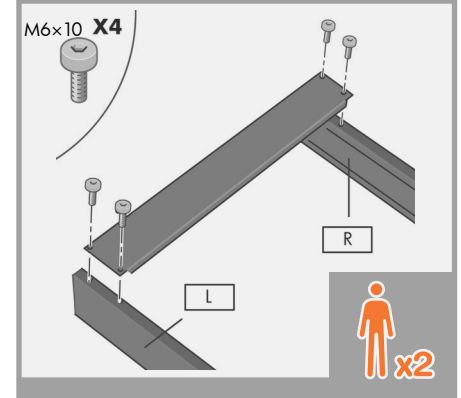

2 Turn the legs upside down, and attach the two feet to the left and right legs.

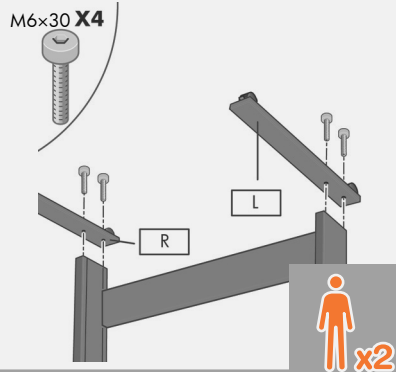

3 Attach the bottom bar to the legs.

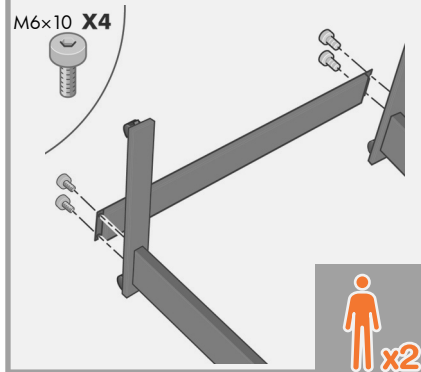

4 Carefully raise the legs into the upright position.



5 Fasten the top bar and wire guide to the two legs using four screws and the two limit stops.

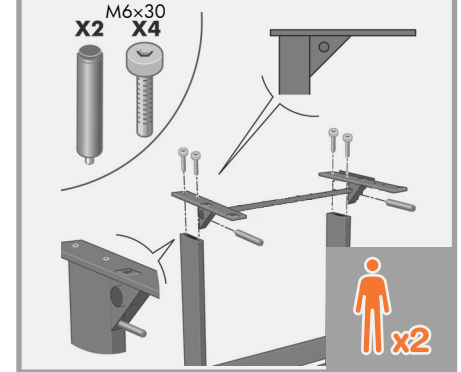

6 Tighten up all screws firmly.

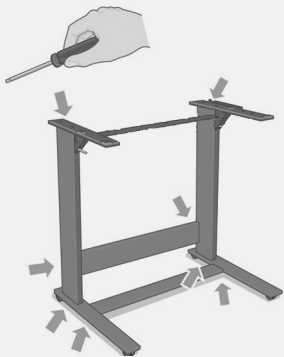

7 Connect the rear table. This is fitted by locating the four guide pins on the rear of the table into the rubber-framed holes on the top bar.

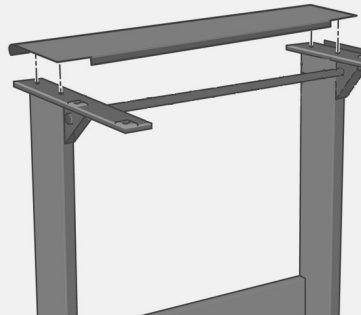

Attach scanner to stand

8 Using two people, remove the scanner from the box. The third person should place some packaging boxes (we recommend the foam end packs from the scanner box) on the floor.

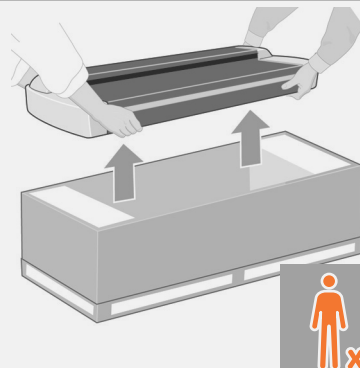

9 Place the scanner onto the packaging boxes.

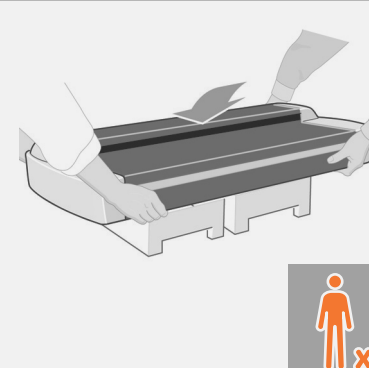

10 Using three people; two to lift, and one to position, lift the scanner into place locating the rubber feet in the holes indicated.

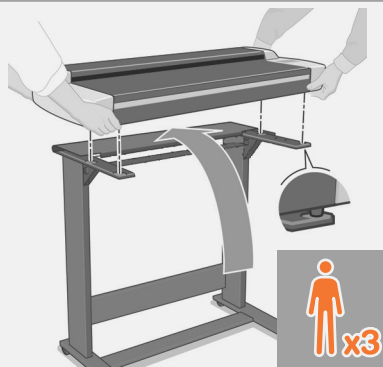

11 Fix with the four special screws using the T-handle hex driver 2.5mm.

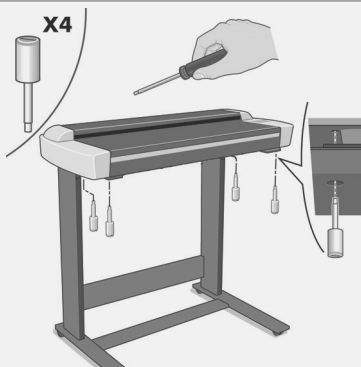

Touch screen assembly

At this point you must decide on which side you are going to fit the touch screen assembly. This can be fitted on the left or right side of the stand.

The next steps, 12 to 22, explain how to fit the touch screen assembly to the right side of the stand.

To fit the touch screen assembly to the left side of the stand, using the same parts, just 'mirror' the assembly procedure described here.



12 Attach the two bracket covers to the touch screen bracket using two screws on the straight bracket cover and two screws and two starwashers on the triangular bracket cover.

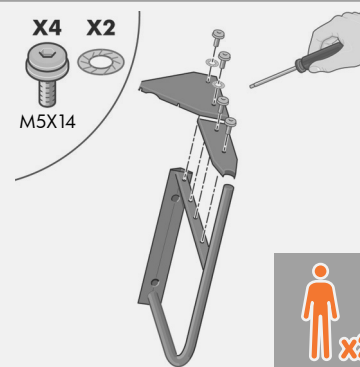

13 Attach two (M6X10) screws to the leg, and two (M5X14) screws with two starwashers; one on the leg and one on the top bar triangular brace piece where shown. Don't tighten them fully; leave a 4mm gap.

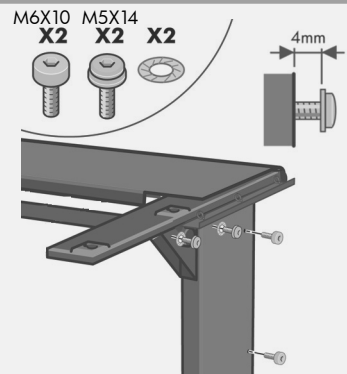

14 Slide the touch screen bracket into place over the four screws.

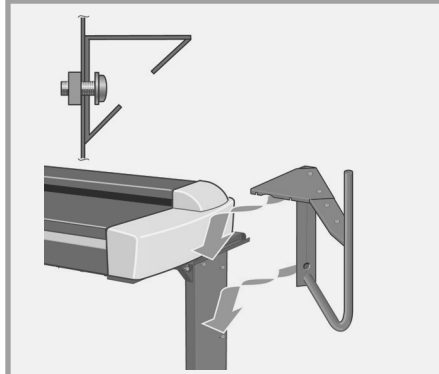

15 Tighten the four screws.

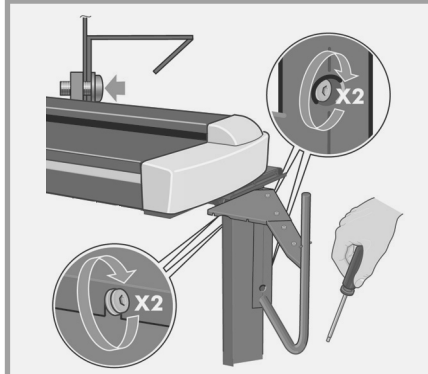

16 Slide the keyboard table onto the touch screen arm.

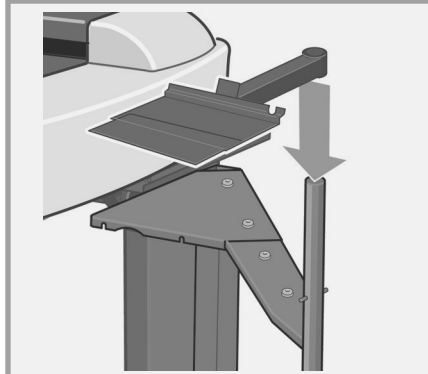

17 Push the keyboard table down until the pointer slots into place on the touch screen arm.

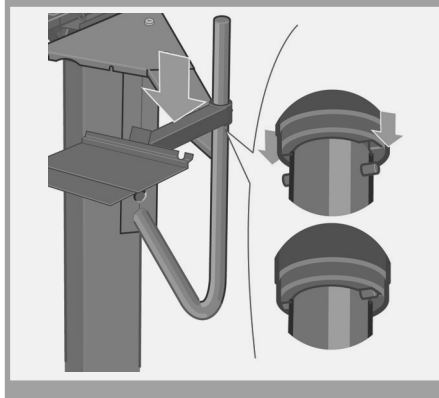

18 With the protective foam in place, put the touch screen face down and attach the monitor joint to the rear along with one end of the earth cable where shown, using four M5x14 screws and one star washer for the earth cable.

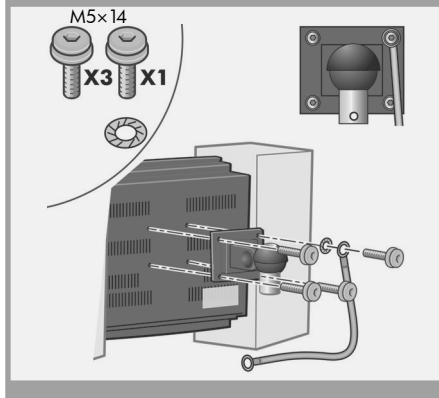

19 Remove the protective foam ends, and slide the hub of the touch screen assembly into the touch screen arm.

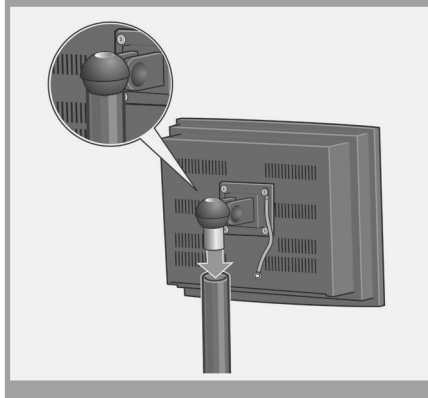

20 Connect the earth cable from the touch screen assembly to the touch screen arm using a screw and star washer.

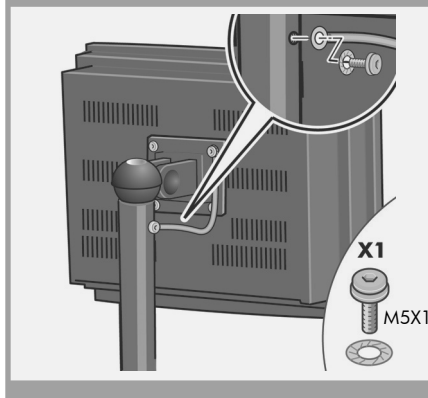

21 Push the keyboard table down until the pointer slots into place on the touch screen arm.

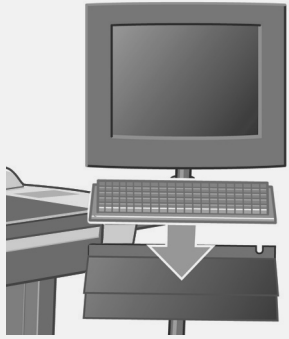

22 Fix the touch screen pen to the side of the touch screen.

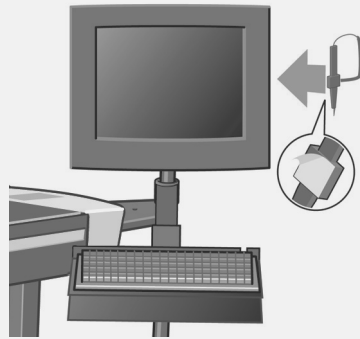

The unit is now assembled and should appear as in the below illustration.



23 Open the scanner corner cover.

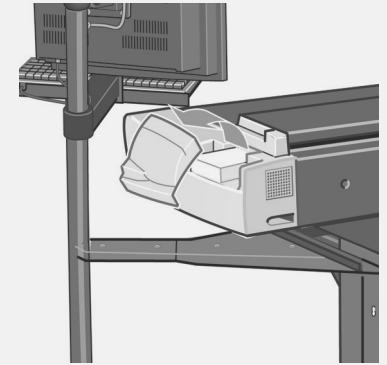

24 Remove the foam retainer from inside the scanner.

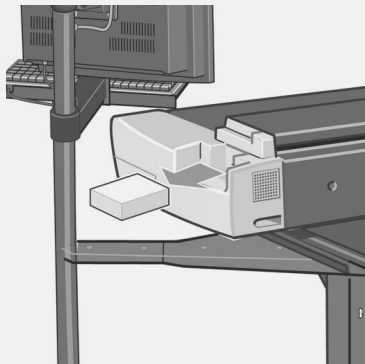

25 Close the scanner corner cover.

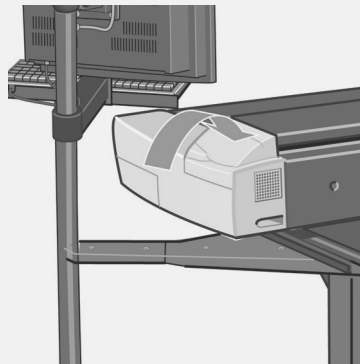

26 Slide the assembled printer under the scanner. The printer's feet will be positioned outside the scanner's feet.

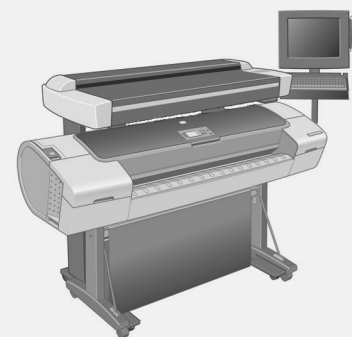

27 Connect the keyboard to the touch screen, passing the cable along the inside of the arm and up through the hole in the keyboard bracket as shown.

Cabling and connecting

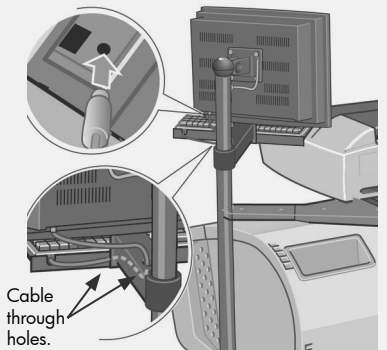

28 Connect the cable bundle to the touch screen as shown (passing it between the bracket and the scanner); inserting the Power, USB, FireWire, and Network connections.

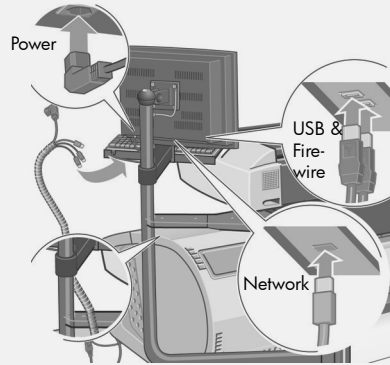

29 Remove the cover on the side of the scanner, and insert one of the FireWire cables through the slot at the back.

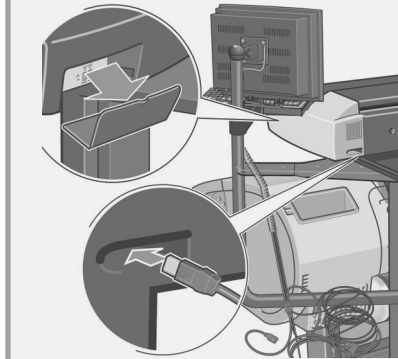

30 Fit the protected part of the bundle cable coming from the screen into four large clips. Attach the clips to the holes in the touch screen bracket covers.

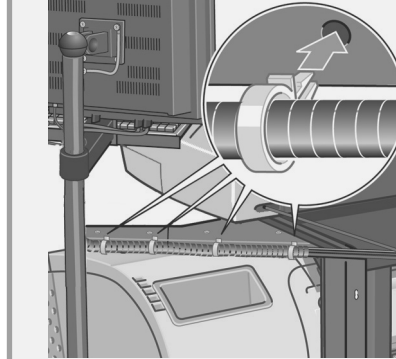

31 Remove the scanner's back cover, and place any excess cable in the space shown below. Replace the cover.

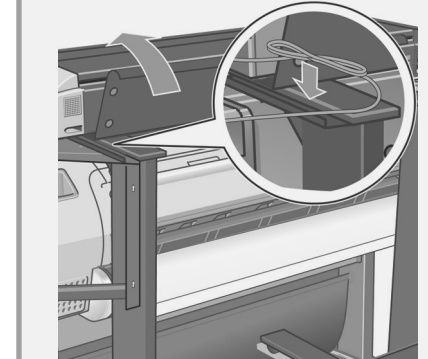

32 Connect the power cable to the scanner.

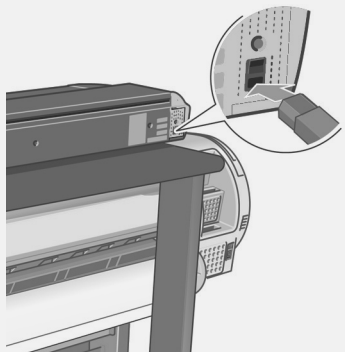

33 Fit the 'Y' power cable into the clips. Then attach the clips to the stand.

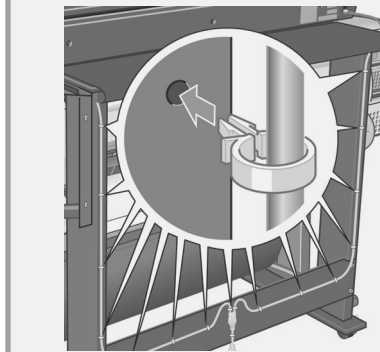

If the touch screen assembly has been mounted on the left leg, the 'Y' power cable should only be attached to the left leg and cross bar.

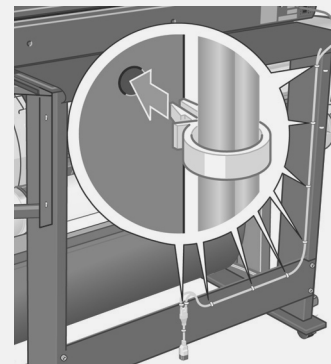

34 Connect the scanner to the printer with the USB cable. Adjust the cable to leave enough slack to be able to pull out the printer when changing paper.

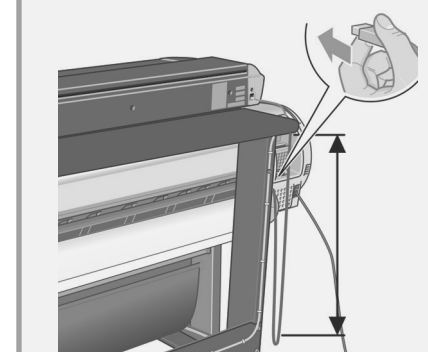

35 Connect the 'Y' power cable to a power outlet.

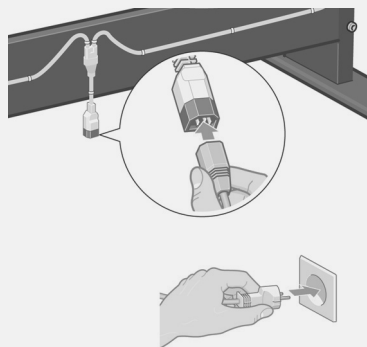

36 If you have not done so already, connect the printer to a power outlet and switch it on.

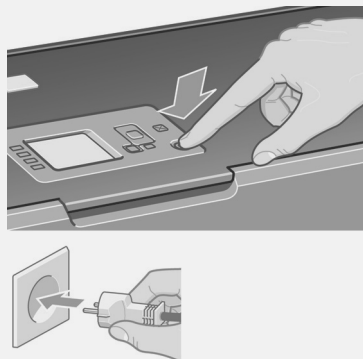

Cleaning the scan area

You are now required to clean the scan area. To do so you will need the cleaning tools provided in the maintenance kit and a cleaning fluid (not included in the maintenance kit).

Caution: do not use abrasives, acetone, benzene, or fluids that contain these chemicals. Do not spray liquids directly onto the scanner glass plate or anywhere else in the scanner.



37 Push down the two locks, and open the scanner cover to expose the scan area.

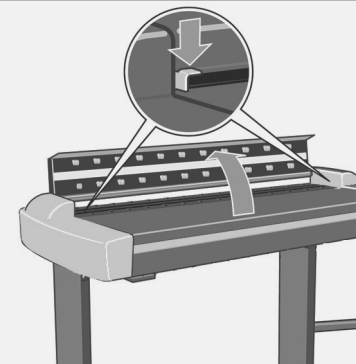

38 Clean the glass with a lint-free cloth and a mild, streak-free, glass cleaner.

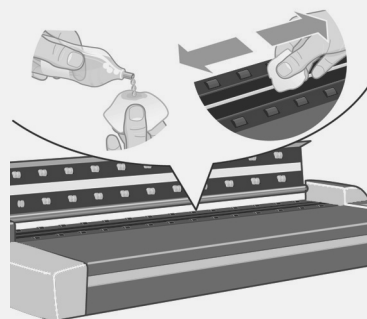

39 Dry the glass fully using a separate clean, dry lint-free cloth like the one provided with the maintenance kit.

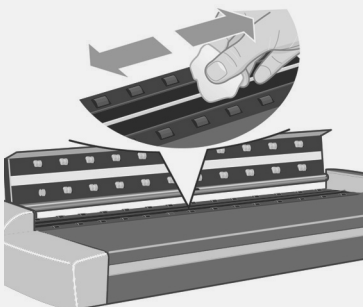

40 Clean the white background plate with a lint-free cloth and a mild, streak-free, glass cleaner.

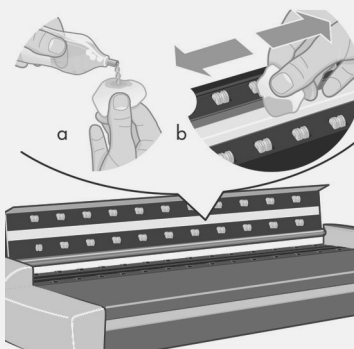

41 Clean the transport rollers and surrounding area.

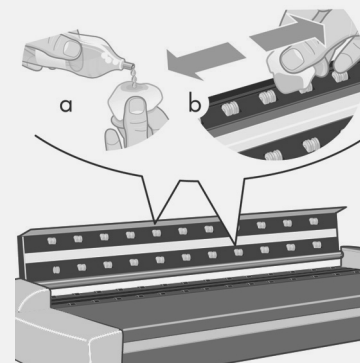

42 Dry the white background plate, rollers, and surrounding area fully using a separate clean, dry lint-free cloth.

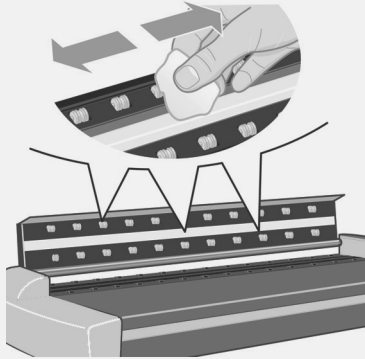

43 Close the scanner cover and push down on the top to lock it into place.

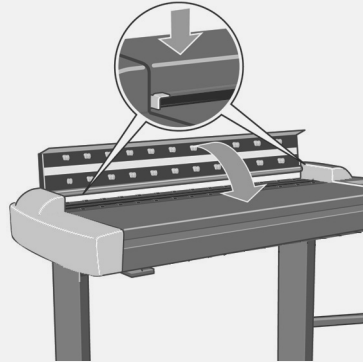

44 Switch on the scanner and leave it to warm up until the orange light goes off, and the green (ready status) light appears.

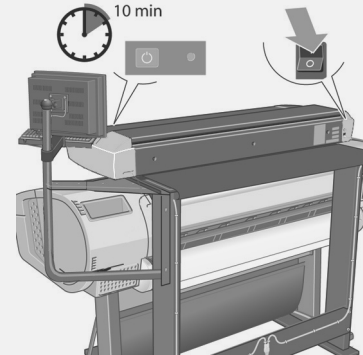

45 When the green (ready status) light has appeared, switch on the touch screen.

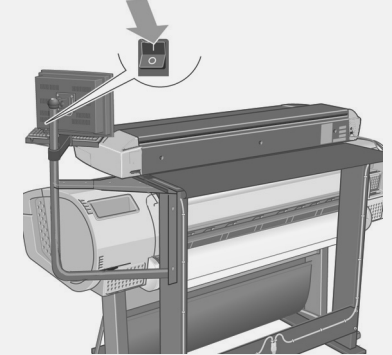

46 To initialise: choose your language (below), read the license agreement, press **I Agree**, and hide the getting started window.

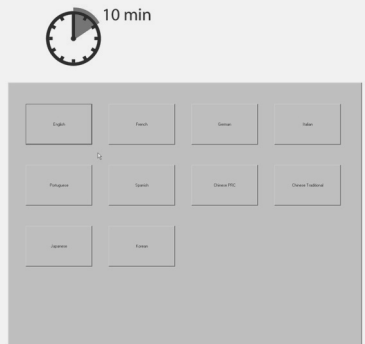

Note: if when switching on the touch screen a **No scanner was found** message appears, please press the **Rescan** option on the touch screen.

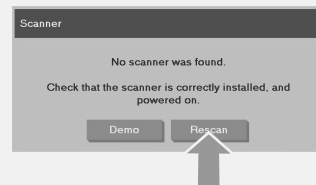

Alignment and calibration

You are now required to calibrate the scanner. For this you will need the scanner maintenance sheet, found in the protective folder shown below.



Important: when setting up for the first time, make sure that the scanner is turned on for at least one hour before moving on to the next step of camera alignment calibration. Slight light intensity changes and camera shifting can occur just after turning the scanner on, and warm-up time will ensure that light conditions and camera heights have stabilized.



- To start the maintenance procedure:
- 1: On the touch screen, press the **setup** tab.
 - 2: Press **Options** button and select Scanning.
 - 3: Press **Scanner Maintenance** Button.

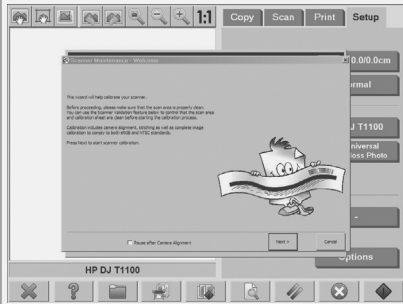

- 47 The maintenance wizard will ask you to insert the maintenance sheet. The sheet's printed side must be face down. Feed the paper in aligning the two midpoint arrows. Press **Next** to continue. Note: if already installed, make sure you remove the magnetic media guides for this part of the process.



Remove the magnetic media guides

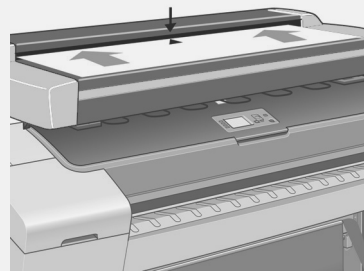

- 48 Now follow the instructions that appear on the touch screen.



Connecting to the printer

- 49 Next, you should check the TCP/IP settings in your touch screen (go to: Setup/Option/System/Advanced/Network settings/IP Address), and correct them if necessary.

If you intend to scan to the network, with the HP Designjet scan software, files to be shared across the network should be placed in the D:\images directory.

Once a file is saved to this directory it can be accessed through the network, from any computer with any operating system.

For more guidance on this issue, see the user documentation that came with your unit.

To add an HP Designjet printer to the printer list in your scanner software, follow these steps:

- 1: On the touch screen go to the setup tab.
- 2: Press option button and select system.
- 3: Press **Install Printer Driver**.
- 4: Press the button for the printer you wish to install.
- 5: Follow the instructions on the screen.

Media profile generation

- 50 Next, you should generate a media profile: first you press button **media profile**, then you press **installed paper**, where asked: **No media profile exists**, click **OK**.



Notes and advice

Keep out dust and reduce maintenance time: when not in use, cover your scanner with the plastic dust cover.



Caution: make sure the scanner power is OFF when using the scanner dust cover.



When the maintenance procedure has completed, remove the scanner maintenance sheet and return it to its protective cover.



Your HP Designjet comes equipped with two magnetic media guides; these can be placed and moved as required.

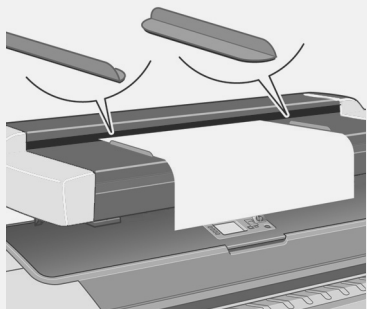

The scanner's ruler can be changed between centimeters and inches by sliding it out, turning it over, and reinserting it.

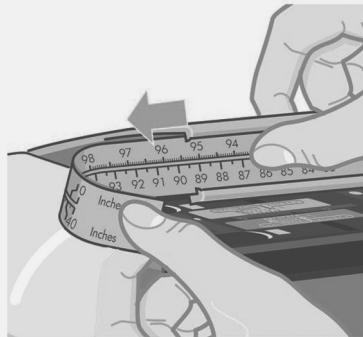

For any further information on how to use your scanner, see the online help system available from your touch screen using the button below.



Keep these instructions

In order to perform routine maintenance (once a month) you will find it useful to refer again to the following sections:

- cleaning the scan area
- Alignment and calibration

