

Install Guide

CD22-E CD32-E CD42-E CD52-E

Outdoor Dome Camera

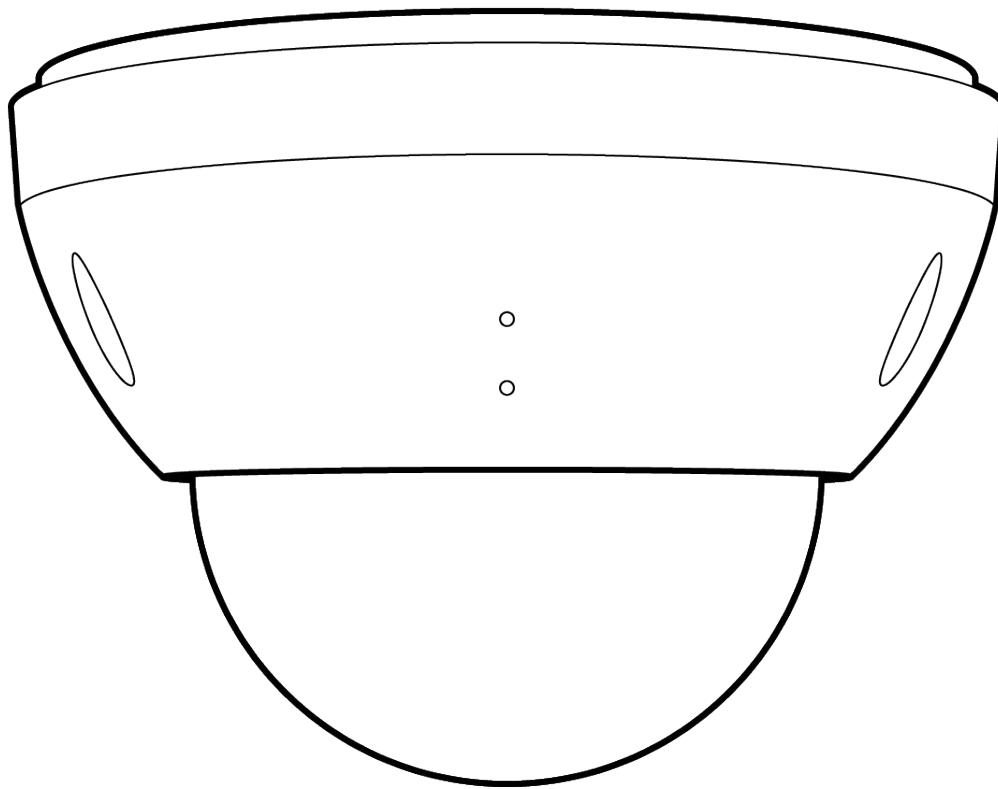

Document

Document Details

v2.0 (20240501)

(v1.0 first published 20211208)

Firmware

Firmware version can be verified on
Verkada Command command.verkada.com.

Product Models

This install guide pertains to models CD22-E-HW,
CD32-E-HW, CD42-E-HW, CD52-E-HW, CD42-E-HW-F,
CD52-E-HW-F.



What's in the box

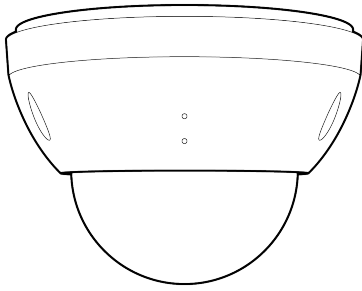

Outdoor Camera

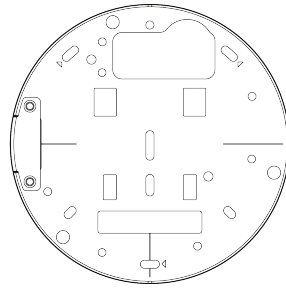

Mount plate
(Attached to camera)

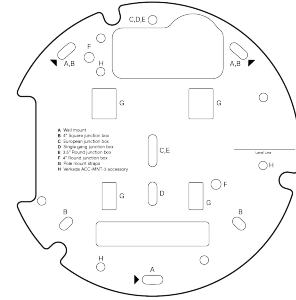

Mounting template

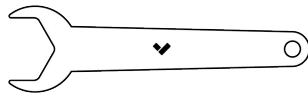

Cable gland wrench

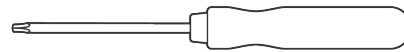

T10 Security Torx screwdriver

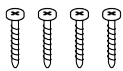

4 M4 x 25mm PH2
wall screws

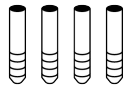

4 Wall anchors



Desiccant

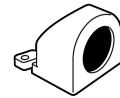

Conduit adapter (with 2
screws and anchors)

What you'll need

- A working Internet connection.
- 802.3af Power over Ethernet (PoE) switch, or a PoE injector. For operation below -20°C , use 802.3at PoE.
- A smartphone or laptop
- A #2 Phillips screwdriver or power drill with a #2 Phillips driver bit
- 1/4 inch (6.5mm) drill bit for wall anchors
- 1/8 inch (3mm) drill bit for pilot holes
- A Cat5 or Cat6 Ethernet cable with a 0.2–0.25 inch outside diameter (5–6.5mm)

Placement

Mount the camera on a wall or ceiling. Try to keep the camera 8 to 10 feet above the ground.

For best night vision, avoid overhangs or obstructions. These may reflect the camera's IR illumination and reduce the image clarity in night mode.

Connect

For easy registration and setup, scan the QR code on the product.

If you prefer to manually register your product, please proceed to: verkada.com/start



LED Behaviors

Regular operation

- **Solid Orange**
Camera is on and booting up.
- ☀️ **Flashing Orange**
Camera is updating firmware.
- **Solid Blue**
Camera is running, connected, and recording data.
- ☀️ **Flashing Blue**
Generic network error. Contact support.

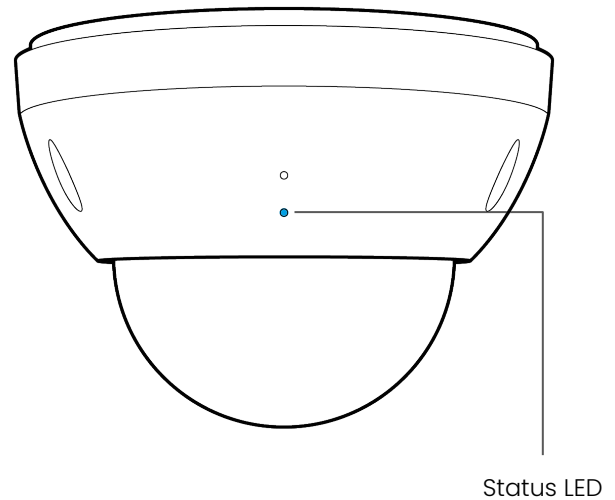

Network errors

The LED will flash in a specific order, depending on the error state. You will see 1 blue flash, followed by a number of orange flashes.

1 Blue, 1 Orange

Camera is connected with PoE, but unable to connect to the Switch.

1 Blue, 2 Orange

Camera has not received an IP address.

1 Blue, 3 Orange

Camera is not able reach the configured Gateway.

1 Blue, 4 Orange

Camera has detected duplicate IP addresses on the LAN.



Example of **1 Blue, 5 Orange** flash sequence

1 Blue, 5 Orange

Camera is not able to resolve Verkada hostnames.

1 Blue, 6 Orange

Camera is not able to receive a response from the NTP Server.

1 Blue, 7 Orange

Camera is not able to certify the SSL connection, likely due to SSL inspection.

1 Blue, 8 Orange

Verkada endpoints are not reachable after boot up.

Installation

Assembly 1/4

Please keep the protective film adhered to the clear bubble until completing the final step of installation.

Use the provided T10 Security Torx security screwdriver to loosen the screws and lift the cover.

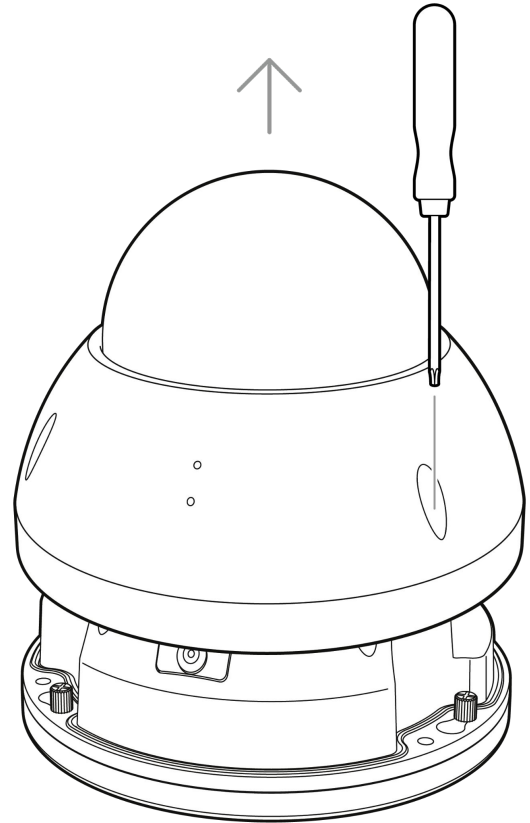

Connect the camera to an 802.3af/at Power over Ethernet port on your network.

An orange LED on the camera's Ethernet port will indicate that it is powered and booting up. A green LED on the Ethernet port will indicate the camera is active.

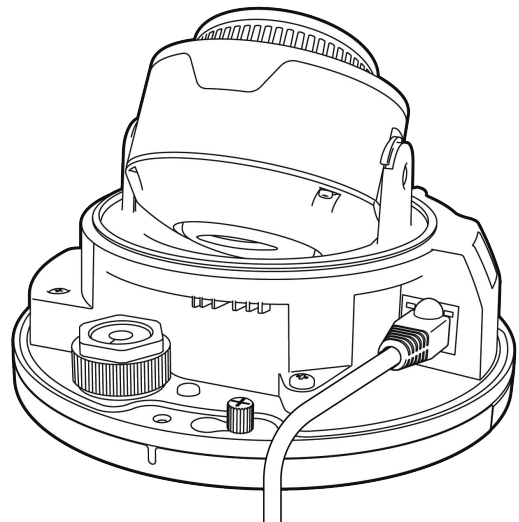

Assembly 2/4

To seal the Ethernet cable, disassemble the cable gland and feed the Ethernet cable through the baseplate through-hole.

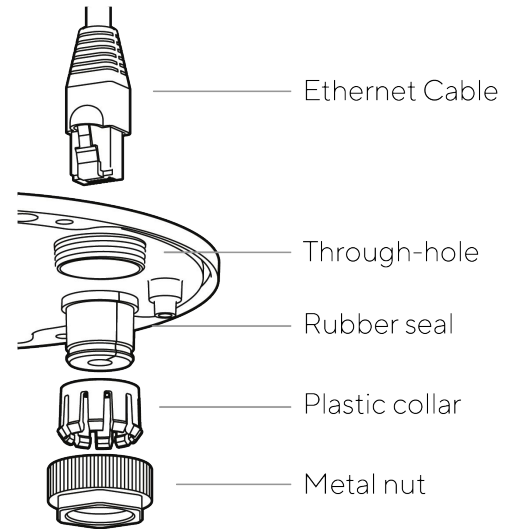

1. Place the rubber seal around the cable. Push the plastic collar firmly over the rubber seal until it snaps into position.

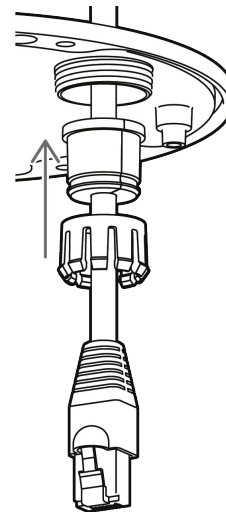

2. Firmly insert the seal and collar assembly into the pass-through until it is secured in position.

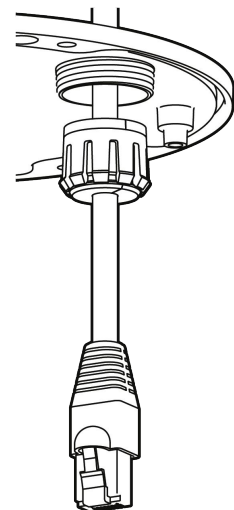

Assembly 3/4

3. Place the metal nut over the rubber seal and engage the threads on the pass-through.

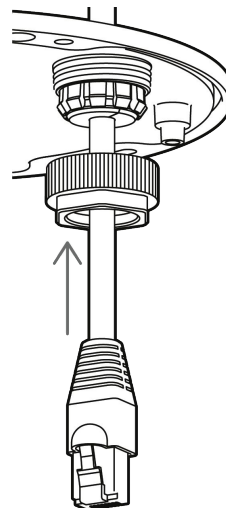

4. Gently tighten down the metal nut by hand. You should still be able to move the cable back and forth through the gland, but have enough resistance for it to remain in place.

For detailed installation instructions, visit www.verkada.com/support

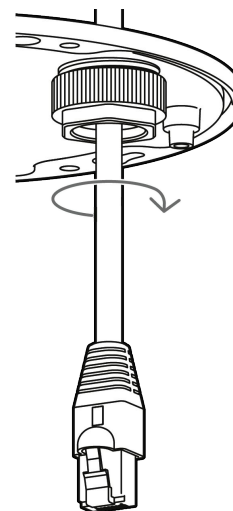

Assembly 4/4

Gently pull the cable through the through-hole so it has some slack, but will not interfere with the top cover.

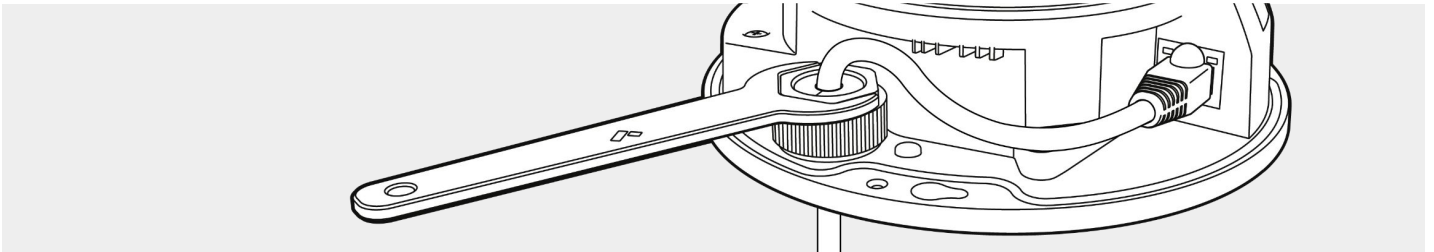
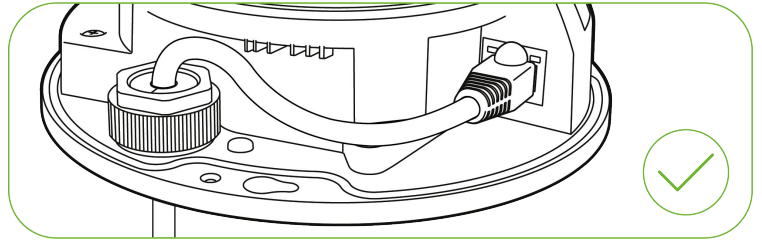

Firmly tighten using the provided Cable gland wrench.

Pulling the Ethernet cable too tight will strain the cable which may impact data performance.

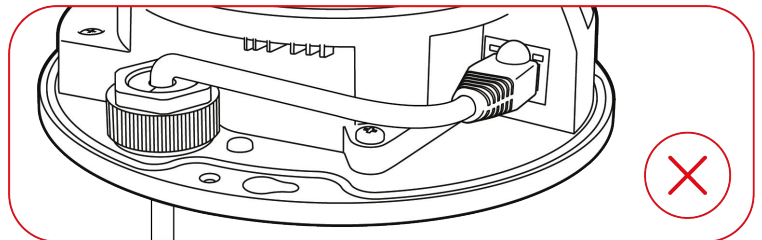

Too much slack in the Ethernet cable may create top cover installation issues.

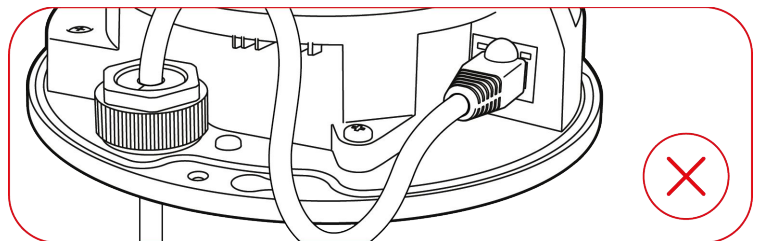

Mounting

1. Use the provided T10 security Torx security screwdriver to loosen the screws and lift the cover. To remove the mount plate, loosen the mount plate screws and twist the camera counter-clockwise. Lift the camera vertically off the base plate and set aside.
2. Use the provided mounting template to mark wall mount holes. For a junction box mount, use the mounting template to determine the correct hole pattern.
3. For a solid material like wood or metal, drill 1/8 inch pilot holes. Drive mounting screws directly into the pilot holes.
4. For drywall, drill 1/4 inch holes. Insert plastic anchors into holes and drive mounting screws into anchors.
5. To secure the camera, place it over the mount plate screws and twist counter-clockwise. Tighten the mount plate screws with a Phillips screwdriver.



Installation

Adjust

Adjust your camera to the desired viewing angle. Use the online stream to confirm image orientation.

Image can be flipped 180° online in Command.

Default image orientation is indicated by markings on the lens face. Video orientation is also adjustable from within the Verkada application.

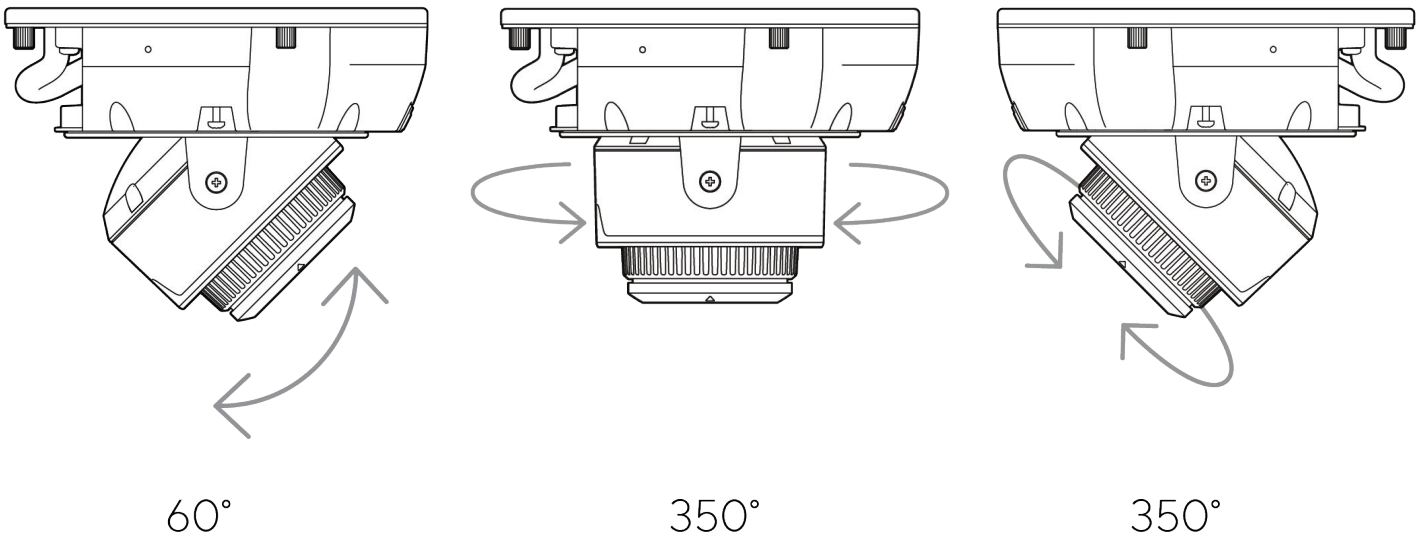

Installation

Secure

Open and remove the desiccant pack from its outer pouch.

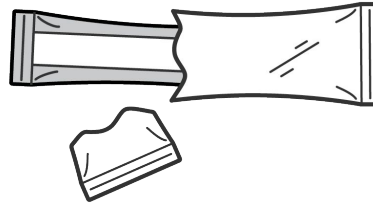

Peel the backing from the double-sided tape on the desiccant pack.

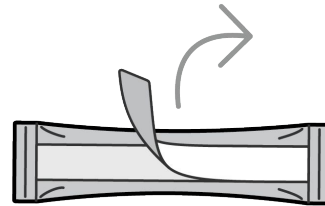

Place the pack directly on to the "Attach desiccant here" text on the interior camera shell.

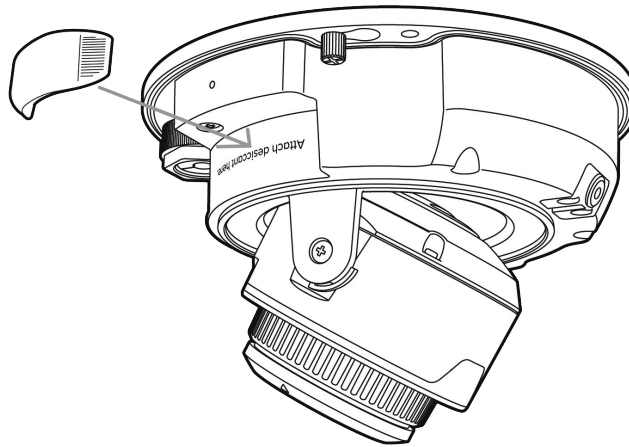

To secure the camera, align the top shell security holes with the baseplate and place the top shell back into its original position. Tighten the security screws using the provided T10 Security Torx screwdriver.

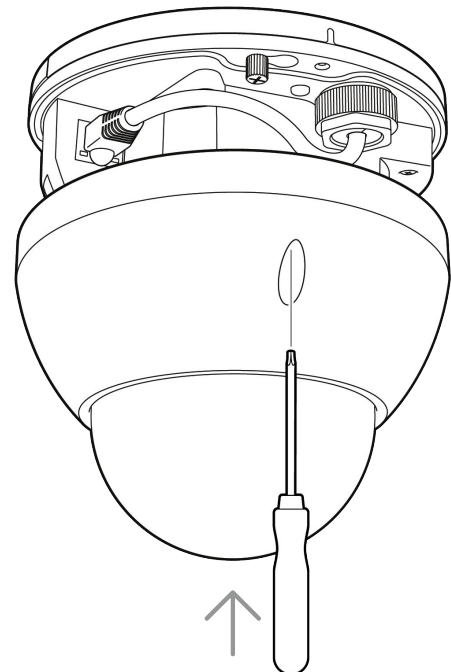

Installation

Grounding

In order to attach the green-yellow grounding cable to the camera, perform the following:

Align a 20AWG or larger grounding cable with a ring terminal and drive an M4-0.7 x 6mm screw (not included) through the terminal and into the threaded grounding point on the back of the device as shown above.

Attach the other terminal of a grounding cable directly to a circuit breaker, ground rod or earth ground.

This unit is powered by PoE through a UL Listed ITE.

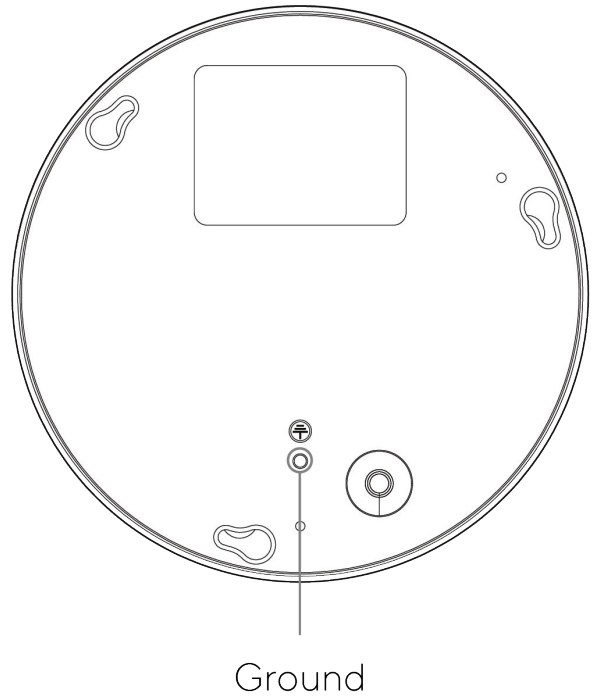

CD22-E CD32-E CD42-E CD52-E Compliance

Caution	<ol style="list-style-type: none">1. Maintenance and repair work must always be carried out by qualified technical personnel. Disconnect power from the unit when performing a maintenance task.2. Wiring methods used for the connection of the equipment to earth shall be in accordance with the National Electrical Code, ANSI/NFPA 70, and the Canadian Electrical Code, Part I, CSA C22.1.3. The product must be installed and protected in a location that is not easily accessible and is away from impacts or heavy vibration.4. The device is only to be connected to PoE networks without routing to outside plants.5. If powered by a power adapter, the adapter should be properly grounded.6. Please contact certified dealers for power adapters.
PoE Adapter	To reduce potential safety issues, only use the PoE adapter provided with the product, a replacement PoE adapter provided by Verkada, or a PoE adapter purchased as an accessory from Verkada.



Appendix

Support

Thank you for purchasing this Verkada product. If for any reason you're experiencing issues or need assistance, please contact our 24/7 Technical Support Team immediately.

Sincerely,
The Verkada Team
verkada.com/support

