

JNP-QSFP-AOCBO-3M-AO

Juniper Networks® JNP-QSFP-AOCBO-3M Compatible TAA Compliant 40GBase-AOC QSFP+ to 4xsfp+ Active Optical Cable (850nm, MMF, 3m)

Features

- Electrical interface compliant to QSFP+ connector (SFF-8436) and SFP+ connectors (SFF-8431)
- Hot Pluggable
- 850nm VCSEL transmitter, PIN photo-detector receiver
- Operating case temperature: 0 to 70°C
- All-metal housing for superior EMI performance
- RoHS compliant (lead free)

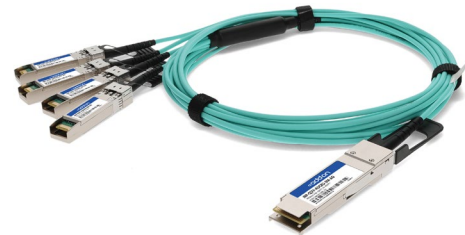

Applications

- 40 Gigabit Ethernet
- Fibre Channel Application
- InfiniBand QDR, SDR, DDR
- High-performance computing clusters
- Servers, switches, storage and host card adapters

Product Description

This is a Juniper Networks® JNP-QSFP-AOCBO-3M compatible 40GBase-AOC QSFP+ to 4xSFP+ active optical cable that operates over multi-mode fiber with a maximum reach of 3.0m (9.8ft). At a wavelength of 850nm, it has been programmed, uniquely serialized, and data-traffic and application tested to ensure it is 100% compliant and functional. This active optical cable is TAA (Trade Agreements Act) compliant, and is built to comply with MSA (Multi-Source Agreement) standards. We stand behind the quality of our products and proudly offer a limited lifetime warranty.

AddOn's direct attach cables are RoHS compliant and lead free.

TAA refers to the Trade Agreements Act (19 U.S.C. & 2501-2581), which is intended to foster fair and open international trade. TAA requires that the U.S. Government may acquire only "U.S. – made or designated country end products."



QSFP Interface Specifications

Parameter	Description
Module Form Factor	QSFP+ (Supports SFF8436/SFF8472)
Channel Data Rate	Rate 40Gbps
BER	<10 ⁻¹²
Operating Case Temperature	0 to + 70°C
Storage Temperature	-20 to + 85°C
Supply Voltage	3.3V
Supply current	180mA per end typical
Management Interface Serial	I ² C (Supports SFF8472)

Optical Characteristics

The following optical characteristics are defined over the Recommended Operating Environment unless otherwise specified.

Parameter	Symbol	Min.	Typ.	Max.	Unit	Notes
Transmitter						
Centre Wavelength	λ_C	840	850	860	nm	
RMS spectral width	$\Delta\lambda$			0.65	nm	
Average launch power, each lane	P _{out}	-7.5		-2.5	dBm	
Difference in launch power between any two lanes (OMA)					dB	
Extinction Ratio	ER	3			dB	
Peak power, each lane				4	dBm	
Transmitter and dispersion penalty (TDP), each lane	TDP			3.5	dB	
Average launch power of OFF transmitter, each lane				-30	dB	
Eye Mask coordinates: X1, X2, X3, Y1, Y2, Y3		0.23, 0.34, 0.43, 0.27, 0.33, 0.4				Hit Ratio = 5x10 ⁻⁵
Receiver						
Center Wavelength	λ_C	840	850	860	nm	
Stressed receiver sensitivity in OMA, each lane				-5.4		1
Maximum Average power at receiver input, each lane				2.4		
Receiver Reflectance				-12		
Peak power, each lane				4		
LOS Assert		-30				
LOS De-Assert – OMA				7.5		
LOS Hysteresis		0.5				

Notes:

1. Measured with conformance test signal at TP3 for BER = 10e-12.

SFP+ Interface Specifications

Parameter	Description
Module Form Factor	SFP+ (Supports SFF8431/SFF8432/SFF8472)
Channel Data Rate	Rate 1 to 10.3125Gbps
BER	<10 ⁻¹²
Operating Case Temperature	0 to + 70°C
Storage Temperature	-20 to + 85°C
Supply Voltage	3.3V
Supply current	455mA maximum
Management Interface Serial	I ² C (Supports SFF8472)

Optical Characteristics

The following optical characteristics are defined over the Recommended Operating Environment unless otherwise specified.

Parameter	Symbol	Min.	Typ.	Max.	Unit	Notes
Transmitter						
Center Wavelength	λ_t	840	850	860	nm	
RMS Spectral Width	P _m			Note 1	nm	
Average Optical Power	P _{avg}	-6.5		-1	dBm	2
Extinction Ratio	ER	3.5			dB	3
Transmitter Dispersion Penalty	TDP			3.9	dB	
Relative Intensity Noise	R _{in}			-128	dB/Hz	-12B reflection
Optical Return Loss Tolerance				12	dB	
Receiver						
Center Wavelength	λ_r	840	850	860	nm	
Receiver Sensitivity	P _{sens}			-11.1	dBm	4
Stressed Sensitivity in OMA				-7.5	dBm	4
Los function	Los	-30		-12	dBm	
Overload	P _{in}			-1.0	dBm	4
Receiver Reflectance				-12	dB	

Notes:

- 1. Trade-offs are available between spectral width, center wavelength and minimum OMA.
- 2. The optical power is launched into MMF.
- 3. Measured with a PRBS $2^{31}-1$ test pattern @10.3125Gbps.
- 4. Measured with a PRBS $2^{31}-1$ test pattern @10.3125Gbps, $BER \leq 10^{-12}$.

Mechanical Specifications

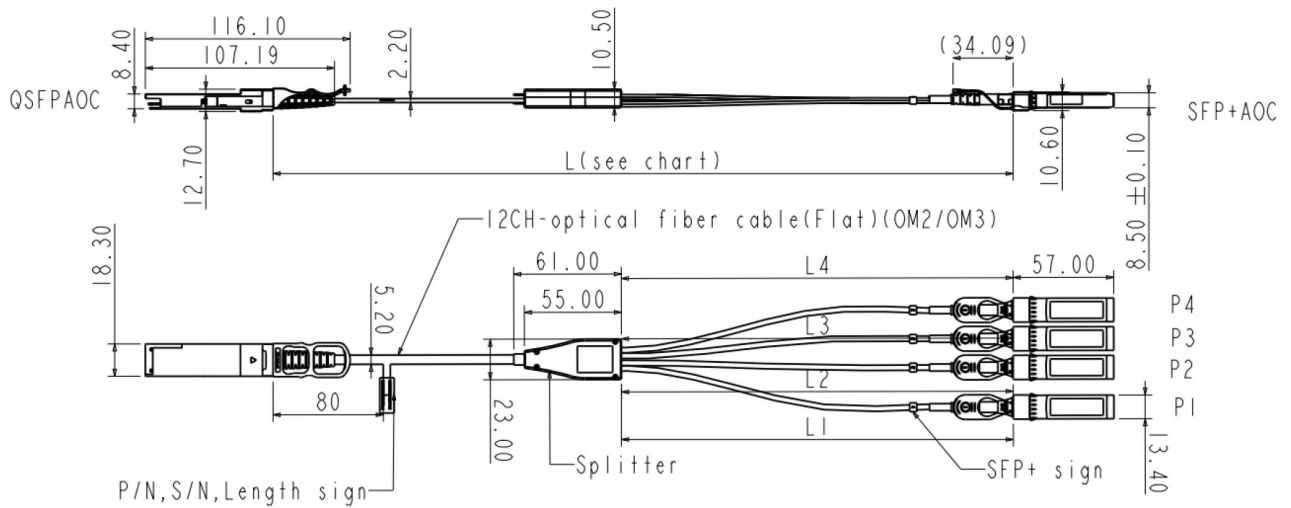

AddOn Networks

In 1999, AddOn Networks entered the market with a single product. Our founders fulfilled a severe shortage for compatible, cost-effective optical transceivers that compete at the same performance levels as leading OEM manufacturers. Adhering to the idea of redefining service and product quality not previously had in the fiber optic networking industry, AddOn invested resources in solution design, production, fulfillment, and global support.

Combining one of the most extensive and stringent testing processes in the industry, an exceptional free tech support center, and a consistent roll-out of innovative technologies, AddOn has continually set industry standards of quality and reliability throughout its history.

Reliability is the cornerstone of any optical fiber network and is engrained in AddOn's DNA. It has played a key role in nurturing the long-term relationships developed over the years with customers. AddOn remains committed to exceeding industry standards with certifications from ranging from NEBS Level 3 to ISO 9001:2005 with every new development while maintaining the signature reliability of its products.

U.S. Headquarters

Email: sales@addonnetworks.com

Telephone: +1 877.292.1701

Fax: 949.266.9273

Europe Headquarters

Email: salesupportemea@addonnetworks.com

Telephone: +44 1285 842070