

Back-UPS™ Pro Uninterruptible Power Supply

BN1350M2

BN1100M2-CA

BR1000MS

BN1375M2

BN1350M2-CA

BR1350MS

BN1500M2

BN1500M2-CA

BR1500MS2

120 Vac

User Manual

EN JPT92208

04/2026

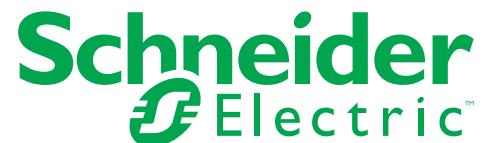

Legal Information

The APC brand and any trademarks of Schneider Electric SE and its subsidiaries referred to in this guide are the property of Schneider Electric SE or its subsidiaries. All other brands may be trademarks of their respective owners.

This guide and its content are protected under applicable copyright laws and furnished for informational use only. No part of this guide may be reproduced or transmitted in any form or by any means (electronic, mechanical, photocopying, recording, or otherwise), for any purpose, without the prior written permission of Schneider Electric.

Schneider Electric does not grant any right or license for commercial use of the guide or its content, except for a non-exclusive and personal license to consult it on an "as is" basis. Schneider Electric products and equipment should be installed, operated, serviced, and maintained only by qualified personnel.

As standards, specifications, and designs change from time to time, information contained in this guide may be subject to change without notice.

To the extent permitted by applicable law, no responsibility or liability is assumed by Schneider Electric and its subsidiaries for any errors or omissions in the informational content of this material or consequences arising out of or resulting from the use of the information contained herein.

Important Safety Instructions

SAVE THESE INSTRUCTIONS - This section contains important instructions that should be followed during installation and maintenance of the UPS and batteries.



This is the “Read user manual” symbol. Read the user documentation carefully and look at the UPS to become familiar with the it before trying to install or operate it.

Read the Safety Guide supplied with the UPS to become familiar with the safety requirements before trying to install or operate the UPS.

Read the instructions in this manual carefully to become familiar with the UPS.

The following special messages may appear throughout this document or on the UPS to warn of potential hazards or to call attention to information that clarifies or simplifies a procedure.



The addition of this symbol either to a “Danger” or “Warning” product safety label indicates that an electrical hazard exists that will result in personal injury if the instructions are not followed.



This is the safety alert symbol. It is used to alert you to potential personal injury hazards. Obey all safety messages that follow this symbol to avoid possible injury or death.

DANGER
DANGER indicates a hazardous situation which, if not avoided, will result in death or serious injury.
WARNING
WARNING indicates a hazardous situation which, if not avoided, can result in death or serious injury.
CAUTION
CAUTION indicates a hazardous situation which, if not avoided, can result in minor or moderate injury.
NOTICE
NOTICE is used to address practices not related to physical injury.

Product Handling Guidelines

<18 kg <40 lb	18-32 kg 40-70 lb	32-55 kg 70-120 lb	>55 kg >120 lb		

Electrical equipment should be installed operated and maintained only by qualified personnel. No responsibility is assumed by Schneider Electric for any consequences arising out of the use of this material.

A qualified person is one who has skills and knowledge related to the construction, installation, and operation of electrical equipment and has received safety training to recognize and avoid the hazards involved.

Safety and General Information

Inspect the package contents upon receipt. Notify the carrier and dealer if there is any damage.

Additional safety information can be found in the Safety Guide supplied with this UPS.

- Adhere to all national and local electrical codes.
- Do not work alone under hazardous conditions.
- All wiring must be performed by a qualified electrician.
- **Changes and modifications to this unit not expressly approved by Schneider Electric could void the warranty.**
- This UPS is intended for indoor use only.
- The UPS is intended for IT environments. Do not operate this unit in direct sunlight, in contact with fluids, or where there is excessive dust or humidity.
- Be sure the air vents on the equipment are not blocked. Allow adequate space for proper ventilation.
- For a UPS with a factory installed power cord, connect the input power cord directly to a wall outlet. Do not use surge protectors or extension cords.
- Always practice safe lifting techniques adequate for the weight of the equipment.

Battery Safety

CAUTION

RISK OF HYDROGEN SULPHIDE GAS AND EXCESSIVE SMOKE

- Replace the battery at least every 5 years or at the end of its service life, whichever is earlier.
- Replace the battery immediately when the UPS indicates battery replacement is necessary.
- Replace batteries with the same number and type of batteries as originally installed in the UPS.
- Replace the battery immediately when the UPS indicates a battery over-temperature condition, or when there is evidence of electrolyte leakage. Power off the UPS, unplug it from the AC input, and disconnect the batteries. Do not operate the UPS until the batteries have been replaced.

Failure to follow these instructions could result in minor or moderate injury and equipment damage.

- Servicing of batteries should be performed or supervised by personnel knowledgeable of batteries and the required precautions. Keep unauthorized personnel away from batteries.
- The batteries typically last for three to five years. Environmental factors impact battery life. Elevated ambient temperatures, poor quality utility power leading to frequent short duration discharges will shorten battery life. The battery should be replaced before end of life.

- Schneider Electric uses Maintenance Free sealed lead acid batteries. Under normal use and handling, there is no contact with the internal components of the battery. Over charging, over heating or other misuse of batteries can result in a discharge of battery electrolyte. Released electrolyte is toxic and may be harmful to the skin and eyes.
- CAUTION: Do not dispose off batteries in a fire. The batteries may explode.
- CAUTION: Do not open or mutilate batteries. Released material is harmful to the skin and eyes and may be toxic.
- CAUTION: Failed batteries can reach temperatures that exceed the burn thresholds for touchable surfaces.
- CAUTION: A battery can present a risk of electrical shock and high short circuit current. The following precautions should be taken when working on batteries:
 - Disconnect the charging source prior to connecting or disconnecting battery terminals.
 - Do not wear any metal objects including watches and rings.
 - Do not lay tools or metal parts on top of batteries.
 - Use tools with insulated handles.
 - Wear rubber gloves and boots.

De-energizing safety

- The UPS contains an internal battery and may present a shock hazard even when disconnected from the branch circuit (mains).
- Before installing the UPS or any accessory be sure that the:
 - Input circuit breaker is in **OFF** position.
 - Internal UPS battery is removed.

Electrical safety

- Do not handle any metallic connector before power has been disconnected.
- To comply with the EMC regulations, wherever applicable, output cords and network cables attached to the UPS must not exceed 10 meters in length.
- The protective earth conductor for the UPS carries the leakage current from the load devices (computer equipment). An insulated ground conductor is to be installed as part of the branch circuit that supplies the UPS. The conductor must have the same size and insulation material as the grounded and ungrounded branch circuit supply conductors. The conductor will typically be green, with or without a yellow stripe.
- Leakage current for a pluggable, Type A UPS may exceed 3.5 mA when a separate ground terminal is used.
- The input power cord of the UPS shall be connected to an earthed mains outlet for safety reasons.
- If the UPS input power is supplied by a separately derived system, the ground conductor must be properly bonded at the supply transformer or motor generator set.

General information

- The model and serial numbers are available on a label located in rear panel of the UPS.
- Always recycle used batteries.
- Recycle the packaging materials or save them for reuse.

EMC Compliance

This equipment has been tested and found to comply with the limits for a Class B digital device, pursuant to part 15 of the FCC Rules. These limits are designed to provide reasonable protection against harmful interference in a residential installation. This equipment generates, uses and can radiate radio frequency energy and, if not installed and used in accordance with the instructions, may cause harmful interference to radio communications. However, there is no guarantee that interference will not occur in a particular installation. If this equipment does cause harmful interference to radio or television reception, which can be determined by turning the equipment off and on, the user is encouraged to try to correct the interference by one or more of the following measures:

- Reorient or relocate the receiving antenna.
- Increase the separation between the equipment and receiver.
- Connect the equipment into an outlet on a circuit different from that to which the receiver is connected.
- Consult the dealer or an experienced radio/TV technician for help.

Inventory

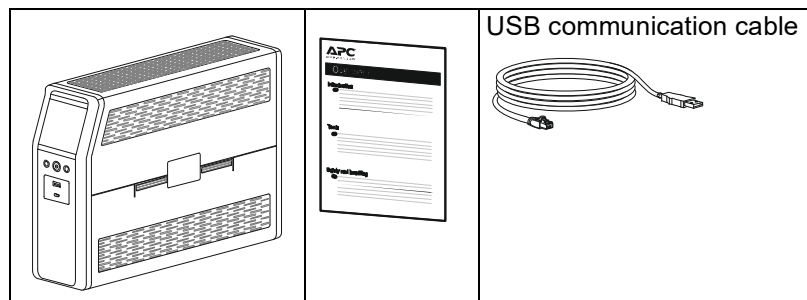

Connect Battery

The UPS is shipped with the battery disconnected.

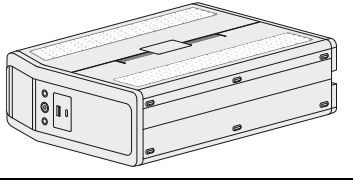
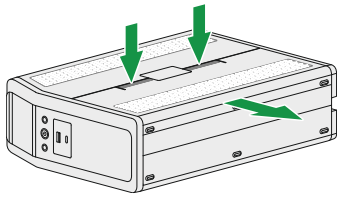
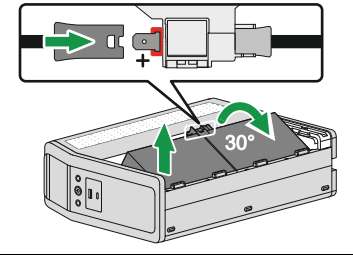
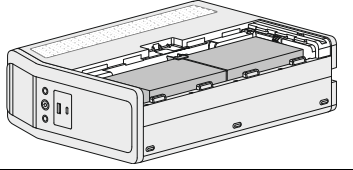
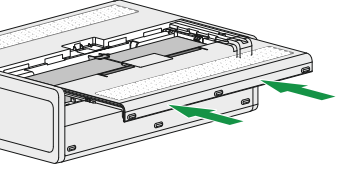
1	Lay the UPS with the battery compartment door facing up.	
2	Press the locking tabs of the battery compartment downwards and pull the battery door away from the UPS to access the battery modules.	
3	Using the handles on both sides of the battery, lift the battery 30° upward to expose the battery connector. Connect the red wire as shown above.	
4	Push the battery into the unit.	
5	Install the battery door.	

Install PowerChute™ Serial Shutdown

PowerChute UPS Management Software (PowerChute Serial Shutdown) can be installed for configuring UPS settings, unattended operating system shutdown, UPS monitoring, UPS control and energy reporting. PowerChute will save any open files on your computer and shut it down. When power is restored, it will restart the computer.

Installation

The following diagram is a representation of a typical installation.

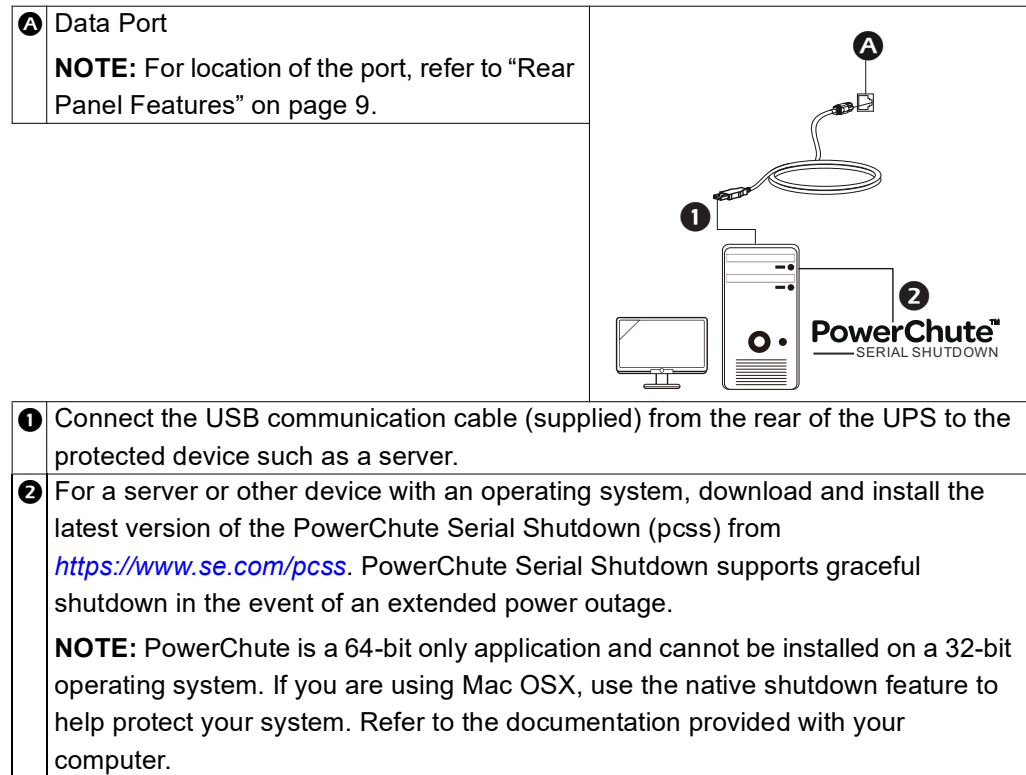

Connect Equipment

Battery Backup outlets with Surge Protection

When the Back-UPS is receiving input power, the Battery Backup with Surge Protection outlets will supply power to connected equipment. During a power outage or other detected AC problems, the Battery Backup outlets receive power for a limited time from the Back-UPS.

Connect critical equipment such as desktop computer, computer monitor, modem or other data sensitive devices to these outlets.

Surge Protected outlets

These outlets provide full-time protection from surges even if the Back-UPS is switched OFF.

Connect equipment such as printers and scanners that do not require battery backup protection to these outlets.

Rear Panel Features

<p>The diagram shows the rear panel of a Back-UPS Pro. At the top left, there are two Ethernet ports labeled 'J'. To their right are two coaxial ports labeled 'A' and 'B'. Below these are two ground screws labeled 'C' and 'D'. In the center, there is a circular indicator labeled 'F'. To the right of the indicator are two rows of outlets: the top row is labeled 'E' (Battery Backup outlets with Surge Protection) and the bottom row is labeled 'G' (Surge Protected outlets). At the bottom center, there is a power cord inlet labeled 'H'. On the far right, there is a circuit breaker labeled 'F'.</p>	<p>A Coaxial ports with surge protection</p>	<p>Connect a cable modem or other equipment with coaxial jacks.</p>
	<p>B Data port</p>	<p>To use PowerChute Serial Shutdown, connect the supplied USB communication cable or an optional serial cable (not supplied).</p>
	<p>C Ground screw</p>	<p>Connect the ground lead from an additional surge suppression device such as a stand-alone data line surge protector.</p>
	<p>D Building Wiring Fault indicator</p>	<p>If this indicator is illuminated, there is a detected problem with the wiring in the building. Contact an electrician immediately and do not use the Back-UPS.</p>
	<p>E Battery Backup outlets with Surge Protection</p>	<p>During a power outage or other detected AC problems, the Battery Backup outlets receive power for a limited time from the Back-UPS. Connect critical equipment such as desktop computer, computer monitor, modem or other data sensitive devices into these outlets.</p>
	<p>F Circuit Breaker</p>	<p>Use to reset the system after an overload condition has occurred causing the circuit breaker to trip.</p>
	<p>G Surge Protected outlets</p>	<p>These outlets provide full-time protection from surges, even if the Back-UPS is off. Connect equipment such as printers and scanners that do not require battery backup protection to these outlets.</p>
	<p>H Input power cord</p>	<p>Connect this power cord to the utility power supply.</p>
	<p>J In/Out Ethernet surge-protected ports</p>	<p>Use an Ethernet cable to connect a modem cable to the IN port, and connect a computer to the OUT port.</p>

Operation

Power Saving Display

The display interface can be configured to be illuminated continuously, or to save energy, it can be configured to darken after a period of inactivity.



- Full Time Mode: Press and hold DISPLAY button for two seconds. The display will illuminate and the Back-UPS will beep to confirm the Full Time mode.
- Power Saving Mode: Press and hold DISPLAY button for two seconds. The display will darken and the Back-UPS will beep to confirm the Power Saving mode. While in Power Saving Mode, the display will illuminate if a button is pressed, it then darkens after 60 seconds of inactivity.

Unit sensitivity



Adjust the sensitivity of the Back-UPS to control when it will switch to battery power; the higher the sensitivity, the more often the Back-UPS will switch to battery power.

- Ensure the Back-UPS is connected to AC power, but is OFF.
- Press and hold the POWER ON/OFF button for six seconds. The load capacity bar will flash on and off, indicating that the Back-UPS is in programming mode.
- Press POWER ON/OFF button again to navigate through the menu options. Stop at selected sensitivity. The Back-UPS will beep to confirm the selection.

BN1100M2-CA, BN1350M2, BN1350M2-CA, BN1375M2, BN1500M2, and BN1500M2-CA

Generator Sensitivity	Default	Sensitive Loads
		
Low sensitivity	Medium sensitivity	High sensitivity
78 - 142 VAC	88 - 139 VAC	88 - 136 VAC
<i>Input voltage is extremely low or high. (Not recommended for computer loads.)</i>	<i>The Back-UPS frequently switches to battery power.</i>	<i>The connected equipment is sensitive to voltage fluctuations.</i>

BR1000MS, BR1350MS, and BR1500MS2

Generator Sensitivity	Default	Sensitive Loads
		
Low sensitivity	Medium sensitivity	High sensitivity
78 - 150 VAC	88 - 147 VAC	88 - 144 VAC
<i>Input voltage is extremely low or high. (Not recommended for computer loads.)</i>	<i>The Back-UPS frequently switches to battery power.</i>	<i>The connected equipment is sensitive to voltage fluctuations.</i>

Front Panel Features and Display Interface Icons

Use the three buttons on the front panel of the Back-UPS and the display interface to configure the Back-UPS.

Front Panel Features

<p>BN1350M2, BN1500M2, BN1100M2-CA, BN1350M2-CA, and BN1500M2-CA</p>	A POWER ON/OFF button
	B Display interface
	C MUTE button
	D USB charging ports: The 2 USB ports (1x Type A and 1x Type C) provide a total 15 W of DC power, and will provide power even when the UPS is on battery.
	E DISPLAY button

<p>BR1000MS, BR1350MS, and BR1500MS2</p>	A POWER ON/OFF button
	B Display interface
	C MUTE button
	D USB charging ports: The 2 USB ports (1x Type A and 1x Type C) provide a total 15 W of DC power, and will provide power even when the UPS is on battery.
	E DISPLAY button

Display Interface Icons



ONLINE

On Line: The Back-UPS is supplying conditioned AC power to connected equipment.



Load Capacity: The load is indicated by the number of sections illuminated, one to five. Each bar represents 20% of the load.

	Battery Capacity: The battery charge level is indicated by the number of sections illuminated. When all five blocks are illuminated, the Back-UPS is at full charge. When one block is filled, the Back-UPS is near the end of its battery capacity, the indicator will flash and the Back-UPS will beep continuously.
	Low Battery: When battery capacity reaches the empty level, the Back-UPS is nearing shutdown and the indicator will flash accompanied by a continuous beep.
	Replace Battery: The battery is nearing the end of its useful life. When the display shows a flashing Replace Battery icon and an empty Battery Capacity icon, replace the battery as early as possible.
	On Battery: The Back-UPS is supplying battery backup power to the connected equipment, it will beep four times every 30 seconds.
EVENT	Event: The event counter shows the number of events that occurred that caused the Back-UPS to switch to on-battery operation.
	System Error Detected: The system has detected an error. The error number will be displayed on the display interface. See <i>“Detected System Errors”</i> on page 13.
	Overload: The power demand from the load has exceeded the capacity of the Back-UPS.
	Mute: If the line through the speaker icon is illuminated, the audible alarm has been turned off.
	Out: Output voltage, frequency.
	In: Input voltage.
AVR	<p>* Automatic Voltage Regulation:</p> <p> When illuminated, the Back-UPS is compensating for low input voltage.</p> <p> When illuminated, the Back-UPS is compensating for high input voltage.</p>
AVR	<p>† Automatic Voltage Regulation:</p> <p> When illuminated, the Back-UPS is compensating for low input voltage.</p>
	Estimated Run Time: This indicates the battery runtime minutes that remain if the Back-UPS switches to battery power.
LOAD	Load: The total load in watts (W) or percentage (%) used by the devices connected to the Battery Backup outlets.

* This feature is applicable only in BR1000MS, BR1350MS, and BR1500MS2.





† This feature is applicable only for BN1100M2, BN1100M2-CA, BN1350M2, BN1350M2-CA, BN1500M2, and BN1500M2-CA

Alarms and Detected System Errors

Audible Indicators

Four Beeps Every 30 Seconds	Back-UPS is running on battery. You should consider saving any work in progress.
Continuous Beeping	Low battery condition and battery run-time is very low. Promptly save any work in progress, exit all open applications, and shut down the operating system.
Continuous tone	Battery Backup outputs are overloaded.
Chirps every 2 Seconds	Battery is disconnected.
Continuous chirping	Battery did not pass the automatic diagnostic test and should be replaced as early as possible. Pressing the MUTE button pauses the chirping.

Status Icons

If these icons flash...	Possible cause
	The Back-UPS is overloaded. Disconnect one of the connected equipment. If the Overload icon stops flashing, the Back-UPS is no longer overloaded and will continue to operate normally.
	The Back-UPS is operating on AC power, but the battery is not functioning properly. Contact Schneider Electric Customer Service to order a replacement battery. Refer to <i>"Battery Replacement"</i> on page 17 for details.
	The Back-UPS is operating on battery power and the battery power is getting low. Shut down all connected equipment to avoid losing unsaved data. When possible, connect the Back-UPS to AC power to recharge the battery.
	The battery is not connected. Refer to <i>"Connect Battery"</i> on page 7 to make sure battery wires are connected properly.





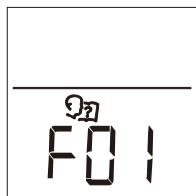



Detected System Errors

The Back-UPS will display these error messages. For all detected errors except F01 and F02, contact Schneider Electric Technical Support.

	F01	On-Battery Overload	Turn the Back-UPS off. Disconnect non-essential equipment from the Battery Backup outlets and the turn Back-UPS on.
	F02	On-Battery Output Short	Turn the Back-UPS off. Disconnect all equipment from the Battery Backup outlets and the turn Back-UPS on. Re-connect equipment one item at a time. If the output is tripped again, disconnect the device that caused the detected error.
	F04	Clamp Short	Errors F04-F09 cannot be corrected by the user, contact Schneider Electric Technical Support for assistance.
	F05	Charge Error	
	F06	Relay Welding	
	F07	Temperature	
	F08*	Fan Error	
	F09	Internal Error	

* Available only in BR1500MS2

Function Button Quick Reference

Function	Button	Timing (seconds)	UPS Status	Description
Power				
Power On		0.2	Off	Press POWER ON/OFF button to start receiving input AC power. If AC input power is not available, the Back-UPS will run on battery power.
Power Off		2	On	The Back-UPS is not receiving input AC power, but is providing surge protection.
Display				
Status Inquiry		0.2	On	Verify the status or condition of the Back-UPS. The LCD will illuminate for 60 seconds. Press the DISPLAY button the toggle into various information.
Full-Time / Power-Saving mode		2	On	The LCD will illuminate and the Back-UPS will beep to confirm the Full-Time mode. The LCD will darken and the Back-UPS will beep to confirm the Power-Saving mode. While in Power-Saving Mode, the LCD will illuminate if a button is pressed, then darkens after 60 seconds of inactivity.
Mute				
Enable/ Disable mode		2	On	Enable or disable the audible alarms. The Mute icon will illuminate and the Back-UPS will beep one time.
Sensitivity		6	Off	The Load Capacity icon will blink, indicating that the Back-UPS is in programming mode. Use the POWER ON/OFF button to scroll through Low, Medium, and High, stop at selected sensitivity. The Back-UPS will beep to confirm selection. See <i>Unit sensitivity</i> for details.
Self-Test (manual)		6	On	The Back-UPS will perform a test of the internal battery. NOTE: This will happen automatically when the Back-UPS is turned ON or when the Back-UPS previously detected a bad battery.
Event Reset		0.2	On	When the Event screen is visible, press and hold DISPLAY button, then press POWER ON/OFF button, to clear the detected error event counter.
Detected Error Reset		2	Error detected	After a detected error has been identified, press POWER ON/OFF button to remove the visual indication and return to standby status.

Troubleshooting

Problem	Possible Cause	Corrective Action
Back-UPS will not switch on.	The Back-UPS is not connected to AC power.	Ensure that the Back-UPS is securely connected to an AC outlet.
	The circuit breaker has tripped.	Disconnect non-essential equipment from the Back-UPS. Reset the circuit breaker. Re-connect equipment one item at a time. If the circuit breaker trips again, disconnect the device that caused the tripping.
	The internal battery is not connected.	Connect the battery.
	The AC input voltage is out of range.	Adjust the transfer voltage and sensitivity range.
The Back-UPS does not provide power during a AC power outage.	Ensure that essential equipment is not plugged into a SURGE ONLY outlet.	Disconnect equipment from the Surge Only outlet and re-connect to a Battery Backup outlet.
The Back-UPS is operating on battery power, while connected to AC power.	The plug has partially pulled out of the wall outlet, the wall outlet is no longer receiving AC power, or the circuit breaker has tripped.	Be sure that the plug is fully secured to the wall outlet. Be sure that the wall outlet is receiving AC power by checking it with another device.
	The Back-UPS is performing an automatic self test.	No action is necessary.
	The AC input voltage is out of range, the frequency is out of range, or the waveform is distorted.	Adjust the transfer voltage and sensitivity range.
The Back-UPS does not provide the expected amount of backup time.	Battery Backup outlets may be fully or improperly loaded.	Disconnect non-essential equipment from the Battery Backup outlets and connect the equipment to Surge outlets.
	The battery was recently discharged due to a power outage and has not fully recharged.	Charge the battery cartridge for 16 hours.
	The battery has reached the end of its useful life.	Replace the battery.
The Replace Battery indicator is illuminated.	The battery has reached the end of its useful life.	Replace the battery as early as possible.
The Overload indicator is illuminated.	The equipment connected to the Back-UPS is drawing more power than the Back-UPS can provide.	Disconnect non-essential equipment from the Battery Backup outlets and connect the equipment to Surge outlets.
The System Error indicator is illuminated, all the front panel indicators are flashing.	There is an internal error detected.	Determine which internally detected error message is displayed by matching the number displayed on the LCD with the corresponding Error Message (refer to <i>“Detected System Errors”</i> on page 13) and contact SEIT Technical Support.

Specifications

	BN1100M2 BN1100M2-CA	BN1350M2 BN1350M2-CA	BN1500M2 BN1500M2-CA
Rating	1100 VA	1350 VA	1500 VA
Maximum Load	600 W	810 W	900 W
Nominal Input Voltage	120 V		
Online Input Voltage Range	88 - 139 V		
Automatic Voltage Regulation	Boost by +11.3% when input voltage drops below limit		
Frequency Range	60 Hz ± 3 Hz		
On-battery Wave shape	Step-approximated sine-wave		
USB charging port	Type C*1, Type A*1 (15 W in total)		
Typical Recharge Time	16 hours		
Transfer Time	8 ms, maximum		
Operating Temperature	32 to 104 °F (0 ~ 40 °C)		
Storage Temperature	23 to 113 °F (-15 ~ 40 °C)		
Unit Dimensions	11.9 × 4.4 × 15.0 in (368 × 100 × 260 mm)		
Unit Weight	27.6 lb (12.5 kg)	22.9 lb (10.4 kg)	25.1 lb (11.4 kg)
Interface	USB and Simple Signal (Serial Data Port)		
On-Battery Runtime	Go to: https://www.se.com/product		
International Protection Code	IP20		
Humidity	0% to 95% relative humidity, non-condensing		

	BR1000MS	BN1350MS	BR1500MS2
Rating	1000 VA	1350 VA	1500 VA
Maximum Load	600 W	810 W	900 W
Nominal Input Voltage	120 V		
Online Input Voltage Range	88 - 147 V		
Automatic Voltage Regulation	Boost by +11.5% when input voltage drops below limit Trim by -11.5% when input voltage exceeds limit		
Frequency Range	60 Hz ± 3 Hz		
On-battery Wave shape	Sine-wave		
USB charging port	Type C*1, Type A*1 (15 W in total)		
Typical Recharge Time	16 hours		
Transfer Time	8 ms, maximum		
Operating Temperature	32 to 104 °F (0 ~ 40 °C)		
Storage Temperature	23 to 113 °F (-15 ~ 40 °C)		
Unit Dimensions	11.9 × 4.4 × 15.0 in (368 × 100 × 260 mm)		
Unit Weight	22.5 lb (10.2 kg)	25.8 lb (11.7 kg)	27.6 lb (12.5 kg)
Interface	USB and Simple Signal (Serial Data Port)		
On-Battery Runtime	Go to: https://www.se.com/product		
International Protection Code	IP20		
Humidity	0% to 95% relative humidity, non-condensing		

Battery Replacement



Always recycle used batteries.
For information on recycling a used battery, refer to the Battery Disposal Information sheet included with the replacement battery.

The battery typically lasts for 3 to 5 years, a shorter period if subjected to frequent outages or elevated temperatures.

Proactively replace batteries to maintain high availability of Back-UPS. Delay in replacing the batteries may corrode the batteries in the cartridge. To ensure protection and high performance, use only genuine APC Replacement Battery Cartridges (RBC™). The APC RBC contains instructions for battery replacement and disposal. To order a replacement battery go to Schneider Electric Web site, www.se.com.

Replace used batteries with APC Replacement Battery Cartridges (RBC). Recycle spent battery cartridges.

UPS Model	Replacement Battery	Battery Module
BN1100M2	APCRBC160	Lead-acid, 12 Vdc, 1 module
BR1000MS		
BN1350M2	APCRBC162	Lead-acid, 12 Vdc, 1 module
BN1375M2		
BN1500M2	APCRBC161	Lead-acid, 24 Vdc, 1 module
BR1350MS		
BR1500MS	APCRBC163	Lead-acid, 12 Vdc, 1 module
BR1500MS2		

Warranty

The standard warranty is three (3) years from the date of purchase. Schneider Electric IT (SEIT) standard procedure is to replace the original unit with a factory reconditioned unit. Customers who must have the original unit back due to the assignment of asset tags and set depreciation schedules must declare such a need at first contact with an SEIT Technical Support representative. SEIT will ship the replacement unit once the defective unit has been received by the repair department, or cross ship upon the receipt of a valid credit card number. The customer pays for shipping the unit to SEIT. SEIT pays ground freight transportation costs to ship the replacement unit to the customer.

Schneider Electric Worldwide Customer Support

For country specific customer support, go to Schneider Electric Web site, www.se.com.



Select models are ENERGY STAR® qualified.
 For more information on your specific model go to Schneider Electric Web site, www.se.com.



Select models are compliant with California (CEC) Battery Charger regulations.
 For more information on your specific model go to Schneider Electric Web site, www.se.com.

Schneider Electric

35 rue Joseph Monier
92500 Ruel Malmaison - France
Phone: +33 (0) 1 41 29 70 00
www.se.com

As standards, specifications, and designs change from time to time,
please ask for confirmation of the information given in this publication.

© 2026 Schneider Electric. All Rights Reserved.

EN JPT92208