

SmartFit® Ergo Dual Extended Monitor Arm

Raise your level of comfort.

K55409WW

Product Description

Finding the correct ergonomic height for your monitors and adjusting their distance is easy, thanks to the sturdy, stable, SmartFit® Ergo Dual Extended Monitor Arm. Clear valuable desk space while improving ergonomics. Wide adjustment range delivers $\pm 90^\circ$ swivel, $\pm 180^\circ$ rotation (for landscape or portrait orientation), $\pm 45^\circ$ monitor tilt adjustment, and up to 399mm/15.7" arm extension. Sturdy metal C-clamp and grommet fastener are easy to install and won't damage or mark the desk or table. Each arm is compatible with displays up to 32" and 8kg/17.6lbs.

Features

- The SmartFit® system makes finding the right height for maximum comfort as easy as 1-2-3. Simply match your hand size to the color on the provided chart, set the height to your color, and you're done.
- Wide adjustment range delivers $\pm 90^\circ$ swivel, $\pm 180^\circ$ rotation (for landscape or portrait orientation), and $\pm 45^\circ$ monitor tilt adjustment for ergonomic comfort.
- Extendable arms let you easily adjust the distance of your monitors (up to 399mm/15.7").
- Included C-clamp and grommet fastener are made of durable steel and aluminum, require less desk space to attach, are easy to install, and won't damage or mark your desk or table.
- Quick-release VESA 75/100 mounting plates accommodate monitors up to 32" and 8kg/17.6lbs (per arm).
- Cable management system eliminates cable clutter for a cleaner desktop.

Specifications

- **PDP Request Quote** Yes
- **Warranty** Limited 2-year warranty

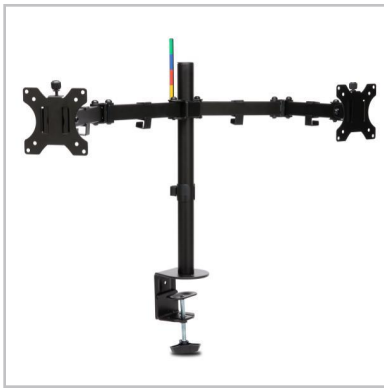

Each information

Depth	6"
Width	23.5"
Height	5.75"
Gross weight	10.58lb
UPC#	085896554097
Unit quantity	1

Case information

Depth	6"
Width	23.5"
Height	5.75"
Gross weight	10.58lb
UPC#	50085896554092

Shipping Information

Country of origin	CN
-------------------	----

General information

Recycled %	0
------------	---