

### Overview

#### HPE OpenSDN Portfolio

As communications service providers (CSPs) pursue their journey to becoming Digital Service Providers, they will need to address one of the most visible challenge in their current network infrastructure: The need for network programmability. That is, the ability to change network behavior on demand and in real time based on business logic or customer demand, and the resulting flexibility and service agility. Network programmability forms the foundation of their ability to adapt to changing customer demands and drive increased revenue by developing and quickly delivering new, innovative and personalized services. Software defined networking (SDN) fulfills that need by transforming networks into programmable elements (“SDN Switches”) implementing forwarding logic that is set dynamically according to business policy, customer demand and system status.

Implementing SDN in a carrier network is a much different than implementing programmability in fairly homogenous networks (like data centers or campus environments) where SDN first originated. SDN implementation in CSP networks need to consider the huge diversity of network elements, vendors and protocols – in addition to the wide, geographically distributed deployments and stringent SLA requirements that are often regulatory mandates. The SDN solution in a CSP network needs to seamlessly integrate with existing management and orchestration solutions. Where CSPs have embarked on a network functions virtualization (NFV) journey, the SDN solution must integrate and add value as a component of the NFV Infrastructure. And most importantly, a CSP SDN solution needs to be an open solution that addresses one of the most common pain point that CSPs talk about – vendor lock in.

The HPE approach to SDN for CSPs is called HPE OpenSDN. OpenSDN is seen as an integral part of the Telco Cloud architecture which aims to transform the CSP infrastructure to be more programmable, operations to be more automated and enables the services provided to be more personalized and on-demand. SDN and NFV play a vital role in that infrastructure transformation. HPE OpenSDN solutions are designed to complement our industry leading NFV solutions to ensure network agility at par with compute and storage agility. HPE solutions enable automated, policy-driven, real-time network programmability to support distributed virtual network function (VNF) deployments, VNF mobility, and are redefining user experience by enabling personalization of services at massive scales.

The HPE OpenSDN portfolio consist of an OpenDaylight-based carrier-grade SDN Controller. HPE adds value to the base controller with a rich set of application packs that form the basis of pre-tested solutions for most commonly used use cases. These application packs include:

- Data center networking with multi-site federation
- Subscriber-Aware Service Function Chaining for consumer broadband Value Added Services
- Service Function Chaining for enterprise vCPE
- CSP provided enterprise VPNs

The HPE OpenSDN portfolio helps CSPs to:

- Quickly add new applications and network services

## Overview

- Deliver services that can be customized in real time based on subscriber, network, application or business policies.
- Easily integrate solutions from many vendors
- Increase network resource efficiency

The HPE OpenSDN portfolio is an integral part of our NFV offering which includes:

- **HPE Helion Carrier Grade OpenStack**
- **HPE NFV System**
- **HPE NFV Director**
- **HPE Service Director**
- HPE Servers and Switches
- HPE Enterprise CPEs

## Data Center Networking Application Pack

HPE OpenSDN for Data Center Networking is an HPE OpenDaylight distribution. OpenSDN is OpenDaylight that is tested, debugged and certified by HPE. Furthermore, HPE adds:

- Testing, documentation
- Technology indemnification
- Professional services and global support

The first releases of the HPE OpenSDN product, as well as the remainder of this document, is focused on implementing and enhancing OpenStack Networking using an OpenDaylight Neutron ML2 Driver for OpenStack, including HPE Helion OpenStack Carrier Grade. This is illustrated in figure 1 below.

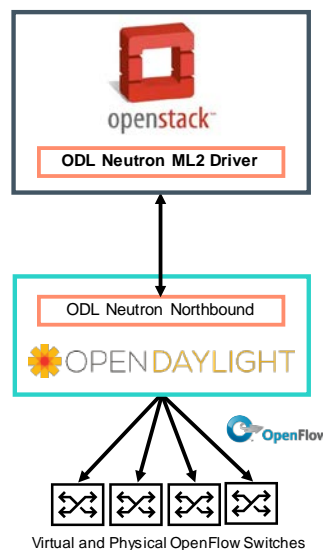

Figure 1. OpenStack Networking with OpenDaylight

OpenSDN has significant forwarding plane acceleration enhancements over OpenStack Neutron and OVS. It utilizes OVS-DPDK to increase the forwarding performance of the Open Virtual Switch by a factor of 10 or more, from around 1-2Gbps per 2 cores to nearly 20Gbps per 2 cores. Furthermore, while traditional Neutron L3 routing requires packets to be sent to a Linux Router,

## Overview

traversing the vSwitch at least twice in the process, OpenSDN implements L3 routing directly on the vSwitch using OpenFlow rules, greatly increasing scalability and performance. Similarly, connectivity to external networks which requires NAT is also accelerated.

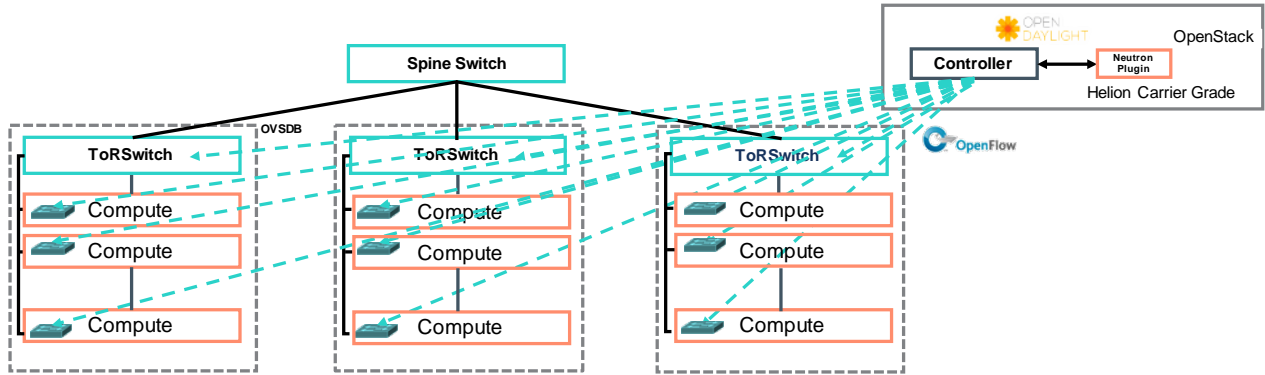

Figure 2. Control Plane

Beyond implementing all required OpenDaylight functions and services as well as northbound and southbound interfaces, HPE OpenSDN adds carrier grade scalability and high availability including clustering of controllers at a single site and federation between controllers at multiple sites as well as the ability of connecting OpenStack instances using the federated controllers.

Federation is achieved using a high performance, massively scalable, distributed database, and thus can be implemented over any IP network without the need to implement BGP.

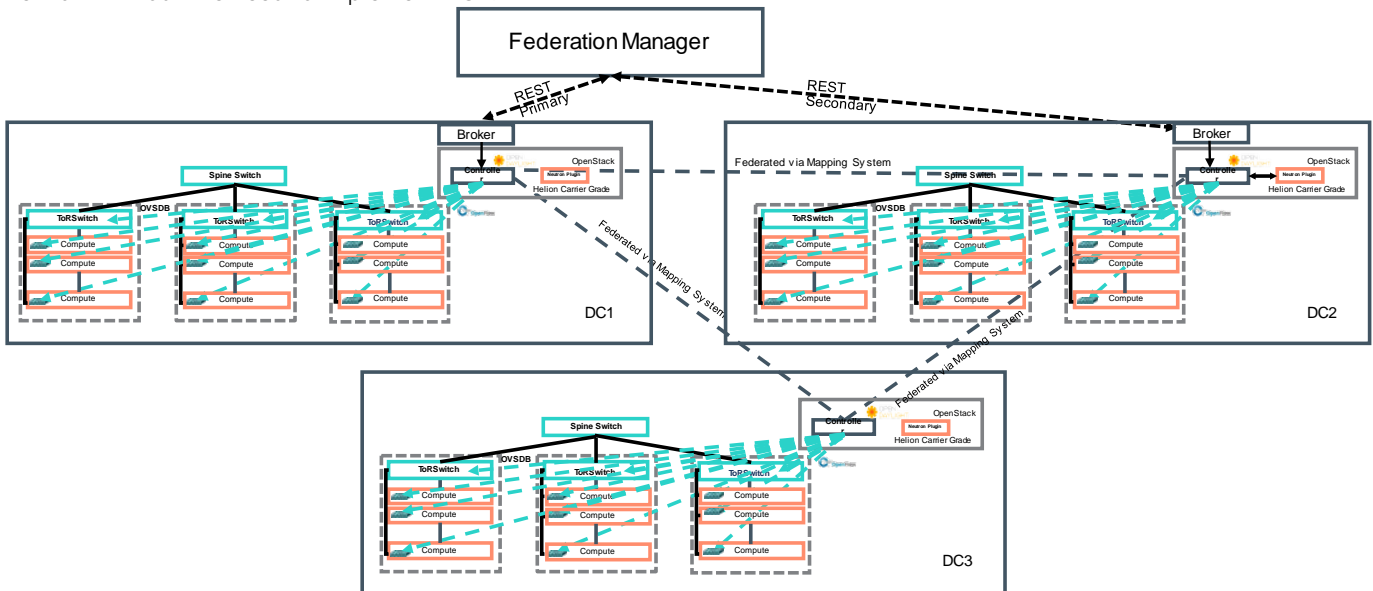

Figure 3. Control Plane: Cross Data Centre Controller and OpenStack Federation

In the data plane, the HPE controller enables inter-site host to host connectivity using VxLAN tunnels between hosts. In addition, the HPE OpenSDN controller adds connectivity to legacy equipment, hosts running bare-metal, SR-IOV or PCI-PT and WAN gateways by implementing VxLAN to VLAN translation using the VTEP capable OpenFlow switches acting as gateways.

### Overview

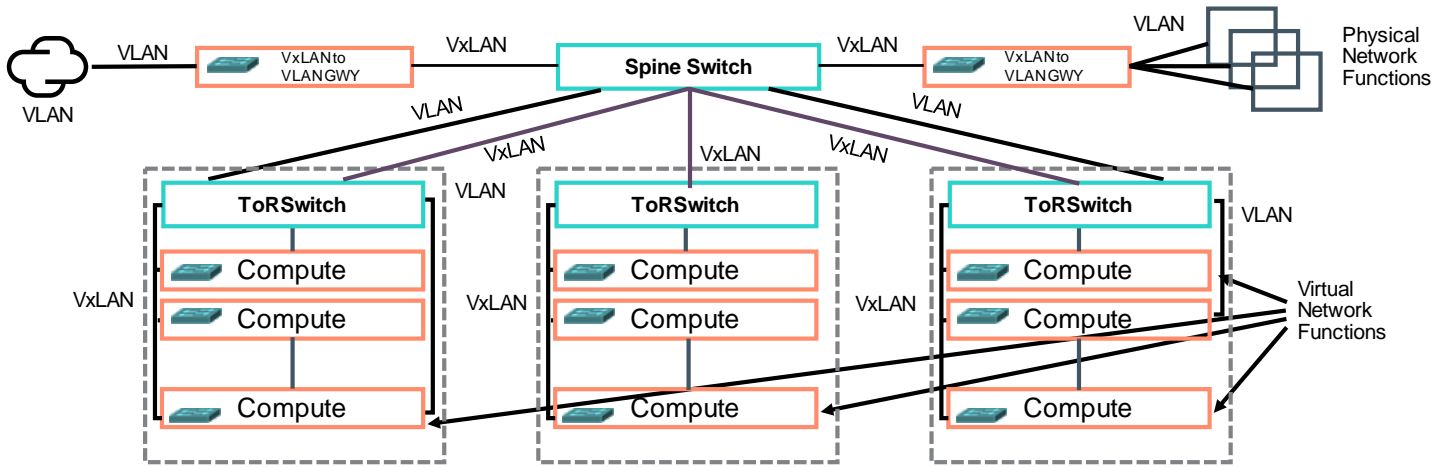

Figure 4. Data Plane: VXLAN tunnels between Compute Node vSwitches VLANs to Nodes without vSwitches (PNF, WAN GWY, SR-IOV, PCI-PT)

The HPE OpenSDN Controller enables Layer 2 and Layer 3 connectivity between sites using VxLAN tunnels and enables federation of OpenStack instances across LAN and WAN boundaries.

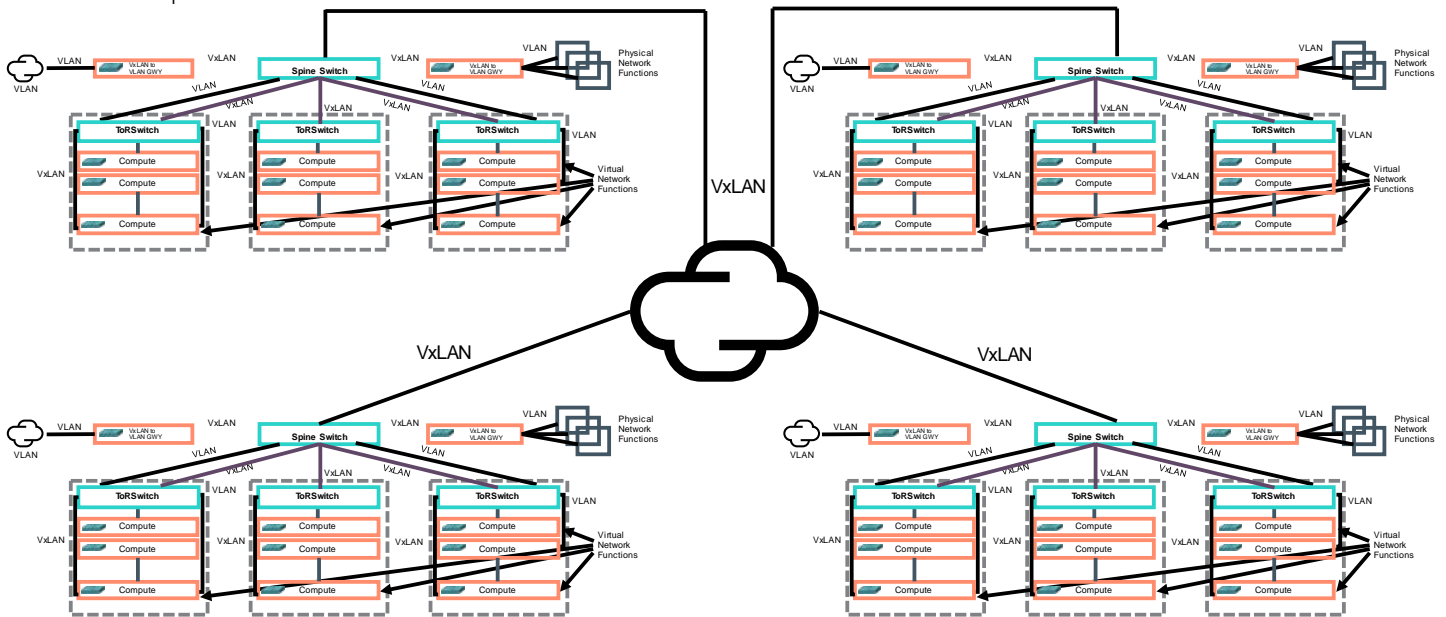

Figure 5. Data Plane Federation: VXLAN tunnels between Sites

## Overview

### SD-VPN Application Pack

SD-VPN is an application pack for HPE OpenSDN, HPE's fully tested, supported, and indemnified distribution of the OpenDaylight SDN controller. It provides the core capabilities for CSPs to create simple, agile VPN solutions for their enterprise customers, without relying on rigid MPLS networks. CSPs can create logical overlay networks and dynamically program customer CPEs using an open-source SDN controller. Instead of relying on dedicated MPLS networks and manual changes to the underlying infrastructure, SD-VPN automates configurations for every VPN.

SD-VPN uses standardized protocols (OpenFlow and OVSDDB) to communicate with enterprise CPEs and dynamically implement the appropriate networking logic for each customer. CSPs can implement MEF Layer-2 Carrier Ethernet services (E-Line, E-LAN, E-TREE), as well as Layer-3 VPNs, in minutes, without the operational overhead associated with conventional MPLS-based approaches. They can create an agile, programmable foundation to provide customized VPN services to thousands of locations, and continually bring new capabilities to their customers.

HPE SD-VPN provides the following capabilities:

- **Flexible SDN control:** HPE OpenSDN, our carrier-grade distribution of the OpenDaylight SDN controller, is the platform for implementing managed VPN services. CSPs can centrally program forwarding logic for customer CPEs and cloud gateways in real time. Using standard protocols such as OpenFlow and OVSDDB, they can extend VPN connectivity to any SDN-controllable CPE—independent of the underlying transport network. Because SD-VPN is an open-source solution, using the dynamic southbound OpenFlow protocol, CSPs retain much more flexibility than when relying on MPLS, or even NETCONF-based approaches. They create an agile, programmable network that allows them to deliver a wide range of networking logic customized for each customer, and continually introduce innovative new services.
- **Customizable overlay networks:** With HPE OpenSDN, CSPs can create simplified, programmable overlay networks that decouple VPN services from the complex underlying transport infrastructure. Using data encapsulation techniques such as VXLAN, GRE and IPsec, they can deliver customized VPN services for thousands of customers—without the need for complex, time-consuming configuration changes on the underlying MPLS network. At the same time, CSPs can extend VPN connectivity over multiple access technologies: Carrier Ethernet, broadband IP, and even cellular networks.
- **Simplified CPEs:** With SD-VPN, all control logic is managed by the SDN controller, so CPEs can be simpler devices, responsible only for handling forwarding according to OpenFlow rules. CSPs and their customers can use a wide range of CPE devices at multiple price points. They can select the right platform, at the right cost, for each location: simple, low-cost CPEs for small branch locations, more robust programmable platforms capable of hosting virtualized services onsite, or even virtual cloud-located CPEs. As long as there is basic connectivity between locations, CSPs can extend carrier-grade, customized VPNs.

### Service Function Chaining Application Pack

HPE OpenSDN is an OpenDaylight-based carrier-grade distributed Software-defined networking (SDN) fabric that enables network operators to create a service abstraction layer on top of traditional networks in order to quickly add new applications, deliver services customized per subscriber, increase network efficiency and improve visibility. HPE OpenSDN offers application packs for use cases including Consumer Broadband Service Function Chaining (SFC), Enterprise Virtual CPE SFC, Data Center Networking and SDN based VPNs.

## Overview

The virtualization of the carrier infrastructure is based on software-driven cost-structures and operational models that use virtualized functions that are not tied to monolithic and proprietary hardware. Carriers are moving to a datacenter paradigm, where network functions are implemented as software running in virtualized environment on commercially available off-the-shelf servers without specialized hardware.

In this ecosystem HPE delivers the virtual networking component. OpenSDN is HPE's carrier SDN solution. As an SDN fabric for NFV, HPE OpenSDN leverages Open Daylight to implement a carrier grade SDN fabric for NFV.

SDN is a datacenter technology. HPE OpenSDN adds the "Carrier" to SDN by addressing the unique requirements of carrier Network Function Virtualization, which differ significantly from those of datacenters. These differences fall into several categories:

**Performance and Capacity:** Carrier applications require capacity in terms of subscribers and flows that greatly exceeds that of typical Data Center applications. A carrier site can, today, handle millions of subscribers translating to 10's of millions of SDN rules. With Machine to Machine support, a multi-site solution can easily reach hundreds of millions of subscribers and billions of rules. This translates into huge capacity requirements for controllers, mapping services and OpenFlow switches, as well as the need for high rates of rules and flow command handling by these entities.

**Reliability:** Carrier networks are expected to be continuously available and provide 99.999% uptime. Thus, redundancy and high availability must be built into every device, network and function. Such reliability is not typically needed in Data Centers.

**Orchestration:** While Data Center orchestration systems typically add and remove VMs and connect them to the network, they are not expected to have a great deal of knowledge of the applications running on the VMs or the policies governing their use. Network Function Virtualization Orchestration systems must understand the applications running on every VM that it spins up for a VNF, apply the policies associated with it (e.g. what other applications need to be spun up together with it) provide it with the required resources and deliver that information to other systems.

**Management and visibility:** Carriers expect a great deal of control and visibility of the applicative operation of their infrastructure. So while in a typical Data Center it is sufficient to be able to configure and view the VMs that are running and their interconnectivity, carriers expect to have control over the applications running on those VMs and to be able to view the overall performance of the network as well as the services and individual functions.

**Networking:** Unlike typical Data Centers in which the underlying network only needs to interconnect an individual tenant's VMs amongst each other, the NFV infrastructure is expected to deliver traffic to and from VNFs VMs in a controlled manner consistent with individual subscriber policy, service profiles, VNF resource availability and status. The NFV infrastructure is required to have knowledge of the required data flow including what VNFs each and every subscriber's traffic needs to flow to/through, in what order and what to do if the VNF is unavailable.

HPE OpenSDN is a distributed software-defined-networking fabric that leverages proven virtualization and grid computing technologies and runs on standard, off-the-shelf computing platforms. It enables network operators to create a service abstraction layer on top of traditional networks that allows to:

- Quickly add new applications and network services
- Deliver services customized per subscriber flow
- Increase network efficiency
- Improve network management and visibility

HPE OpenSDN, leverages OpenDaylight and standard SDN mechanisms such as OpenFlow, OVSDDB and OpenStack to fully separate control from forwarding, location from identity and orchestration from networking.

## Overview

The OpenSDN architecture features:

**Federated Control:** It controls traffic flows through the network using a distributed controller and virtual switches to efficiently load balance traffic on all resources, whether virtual or physical.

**Subscriber Awareness:** The solution identifies and steers traffic to the specific subset of network functions or services needed to support each subscriber flow.

**Distributed Mapping:** A service that allows for scalable location identity separation for endpoints including subscribers, virtual network functions and service elements. The service maps identity to location, policy and other subscriber characteristics that are required for optimal operation.

**Overlay Network:** Abstraction layer formed by the nodes allows the mobility of the users, VMs, content or any other endpoint while maintaining consistent policies across the network. It has global knowledge of policies and the network environment. The overlay is shielded from the states of the underlying network switches and routers and it does not have to sync with them. Through simple APIs, it enables fine-grained traffic engineering while mitigating the increasing burden of packet tagging and various other virtualization workarounds

**Standards-based:** ContexNet provides standards-based extensibility using OpenFlow, OpenDaylight, NVO3, OpenStack and more.

**Standard Hardware Deployment:** It runs on standard, off-the-shelf computing platforms and is hypervisor-agnostic.

### Consumer Broadband Service Function Chaining

In today's largely physical networks, it is very common for operators to deploy middle boxes for advanced services, such as intrusion detection and prevention systems (IDS/IPS); firewalls; content filters and optimization mechanisms; deep packet inspection (DPI); caching; etc. These functions are usually deployed as appliances on proprietary hardware and installed in the data path at fixed locations in or at the edge of the carrier core network. As a major example of service function chaining in operator networks, consider the Gi/SGi interface is the "reference point" defined by 3GPP between the mobile packet core and packet data networks (PDN). Typically functions deployed at this point are middle-boxes and do not use the traditional client-server, destination based forwarding paradigm of IP and Ethernet. Rather, traffic flows through them in a sequence. They are often implemented as logical or physical "rails" with all bearer traffic going through all of them. This is illustrated in below

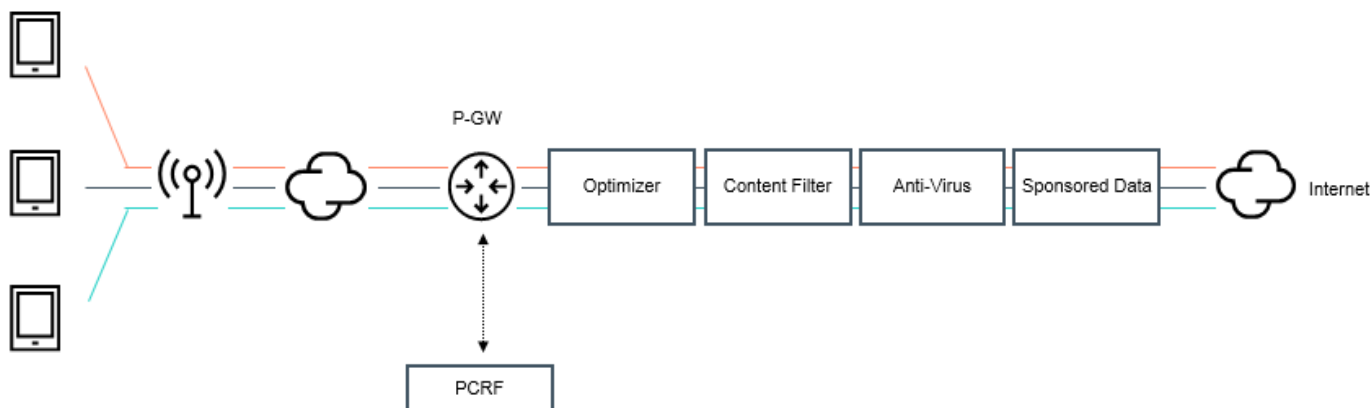

Figure 6. Consumer Broadband and middle boxes – SGI-LAN Interface Example

Network operators are currently experiencing large growth in traffic. Increased adoption of smartphones, new applications and faster access networks are factors that have contributed to this increase in traffic. Today operators typically deploy functions like Deep Packet Inspection, Caches, Video optimization, TCP optimization, NAT and Firewall for subscribers accessing Internet based content/services. Currently these functions are deployed on dedicated hardware components inline to the network in "rails". Both ETSI and IETF have identified the problem with networking middle boxes. Within ETSI this has been identified as VNF Functional Graph (VNF-FG) use case for NFV. IETF has a Service Function Chaining Working Group also working on this area.

## Overview

The current implementation of middlebox service chains creates inefficiencies that are addressed by virtualization:

Every function needs to have carrier class design, reliability and redundancy

Each function must be sized for peak demand

Load cannot be distributed across multiple sites or operator networks

Implementation and deployment is slow and time consuming

Upgrades, backups and other maintenance operations cannot be standardized

Multiple middleboxes need to interface with such systems as AAA and OSS

Virtualized Network Function elasticity is difficult or impossible

All functions must be collocated with the PGW

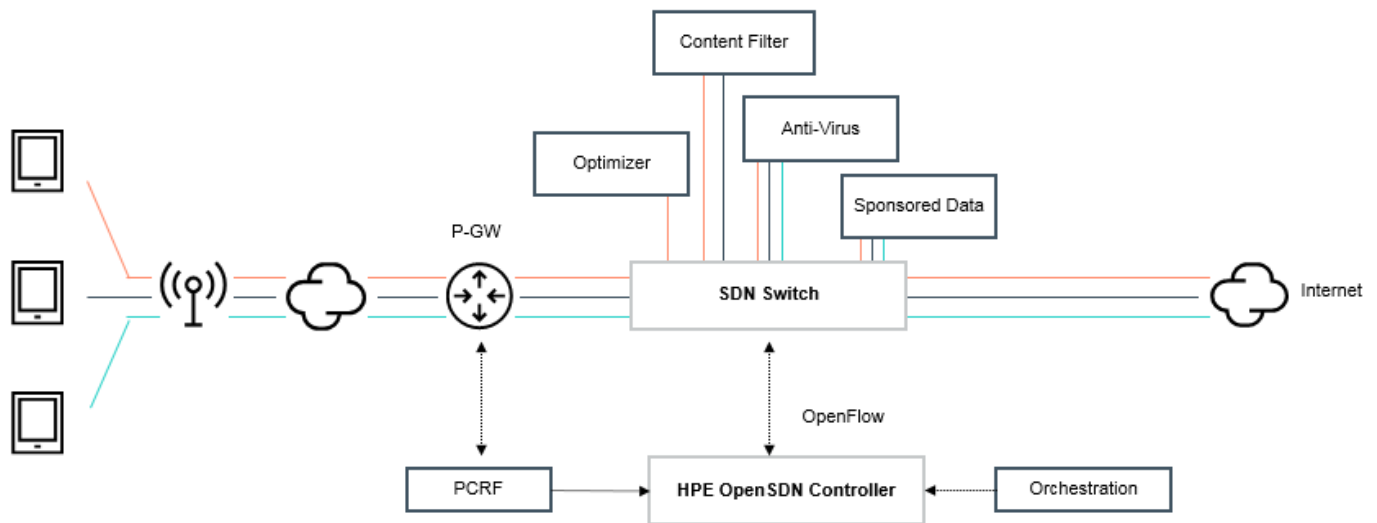

Figure 7. HPE OpenSDN Consumer Broadband Service Function Chaining

Virtualizing consumer broadband services with HPE OpenSDN, as illustrated above, addresses these concerns resulting in a more cost effective network that delivers services quicker and more reliably. HPE OpenSDN implements the network fabric that dynamically connects middlebox Network Functions, allowing them to move out of the data path and, optionally, be virtualized. HPE OpenSDN implements the connectivity, load balancing and redundancy for each function.

HPE OpenSDN redirects the traffic of each subscriber via only those functions that the subscriber requires. In this manner, resources are sized to current load, are shareable across functions and can be offloaded to other sites during peak demand. New services can be deployed quickly, initially serving only a subset of the subscribers until they are proven. Maintenance is simplified and interfacing to AAA and OSS can often be restricted to HPE OpenSDN which can provide the required subscriber data to the network functions and report on the health of each network function.

HPE OpenSDN, via its AAA Brokers, receives and pulls subscriber data from AAA sources such as RADIUS and PCRF, determines the service chaining policy for the subscriber and creates service chains, with each subscriber being assigned the service profile that determines the upstream and downstream network functions that the subscriber's traffic will flow through. ContextNet load balances subscribers amongst network function instances and handles all redundancy and failover mechanisms.

In a virtualized environment, HPE OpenSDN integrates with VNF Managers and Orchestration to receive information about VNF instances that are created or removed. It uses this information to add or remove VNF instances from the load balancing and high

## Overview

availability schemes. Furthermore, HPE OpenSDN can provide feedback to these systems on the status of each VNF instance, allowing them to take corrective action as required.

Communications between nodes is achieved using an overlay network (VxLAN), which enables end to end service function chaining without the need for control of the intervening inter-datacenter networks. This allows services to traverse any kind of IP network including legacy networks and 3rd party networks.

As a result, the inefficiencies listed above are ameliorated or eliminated altogether:

- Only relevant traffic sent to each network function
- Fast service introduction by sandboxing with limited set of subscribers
- Integrated load balancing
- Single AAA interface
- All reliability mechanisms handled by ContextNet
- Elasticity enabled by integration with NFV Orchestration
- Network functions can be local or remote

### ContextWare

HPE OpenSDN includes a Network Function (ContextWare) that implements a number of key capabilities. These include:

- TCP Optimization
- TCP Bridge between WAN and Access networks
- Accelerates subscriber traffic
- Splits latency, larger windows, access specific congestion windows
- Data Sampling API
- Enables video, image and multicast optimization
- Utilizes subscriber information and measured data rates
- Deployed with partner optimizers
- Analytics collection
- Detailed data on every HTTP session and TCP connection
- Real time output to data warehouse and / or analytics collection systems
- Enables network visibility, usage patterns and personalized advertising
- HTTP Header Enrichment
- Allows subscriber data to be sent to in-house and external servers
- Enables personalized advertising, custom billing
- Optional secure encryption mechanisms
- URL blocking
- Enables specification of specific hostnames of websites
- Blocks subscriber traffic to and from these websites

### Enterprise vCPE Service Function Chaining

For operators delivering broadband connectivity, VPNs and datacenter applications to enterprises, the opportunity for delivering value added services presents similar opportunities, and challenges as it does for consumer broadband. Such services, such as security, optimization and virtual routing, can be implemented either at the customer premises using customer premises equipment (CPE) or in the operator POP. The advantages of deploying such services in the operator premises are significant. They include:

- Sharing of hardware and software licenses among customers to reduce costs
- Simpler deployment and provisioning

## Overview

Eliminate costs of customer site visits / truck rolls  
Enable virtualization for further sharing of hardware

The conventional architecture for deploying such services is, as in the consumer broadband case, implemented using dedicated hardware components inline to the network. These present similar disadvantages to those found in the consumer broadband network including:

- Load balancers required for every service function
- Need for carrier grade high availability in every function
- Sizing for total peak demand
- Slow rollout of new services
- Difficult to virtualize

HPE OpenSDN offers an alternative: Service Function Chaining for Enterprise vCPE. By implementing service function chaining of virtualized or physical service elements on a per-enterprise basis, HPE OpenSDN Enterprise vCPE SFC overcomes these challenges, by redirecting traffic via the service functions, and only those service functions that the enterprise has signed up for or the operator has provided due to other reasons. HPE OpenSDN implements load balancing, high availability and enables virtualization by integration with orchestration. HPE OpenSDN thus allows operators to reduce the cost of hardware and software licenses of such services, accelerate new service introduction, ease provisioning and enable the benefits of virtualization.

## HPE Licenses

HPE OpenSDN offers simplified pricing per subscriber or per Gb/s throughput and simultaneous subscriber IP addresses.

### HPE OpenSDN SKUs

HPE OpenSDN 10K Mobile Broadband Sbscrbrs IP Addrss Steering Max 6 VNF 1yr 24x7 Supp Perp Lic E-RTU	<b>P8A91AAE</b>
HPE ContexWare 10K Mobile Broadband Sbscrbrs IP Addrss TCP Optmztn 1yr 24x7 Supp Perpetual Lic E-RTU	<b>P8A92AAE</b>
HPE ContexWare 10K Sbscrbrs Header Enrichment (Min 250K Sbscrbrs) 1yr 24x7 Supp Perpetual Lic E-RTU	<b>P8A93AAE</b>

## Overview

HPE ContexWare 10K Mobile Broadband Sbscrbrs IP Address Analytics 1yr 24x7 Supp Perpetual Lic E-RTU	<b>P8A94AAE</b>
HPE ContexWare 10K Mobile Broadband Sbscrbrs IP Addrss Vid Optmztn API 1yr 24x7 Supp Perp Lic E-RTU	<b>P8A95AAE</b>
HPE ContexWare 10K Mobile Broadband Sbscrbrs IP Addrss Web Site Blckng 1yr 24x7 Supp Perp Lic E-RTU	<b>P8A96AAE</b>
HPE OpenSDN for up to 20Gbps or 1 Million IP Addresses 1yr 24x7 Support Perpetual License E-RTU	<b>P8A97AAE</b>
HPE ContexNet vE-CPE SFC Infrastructure (200 small / 80 sites / 40 large sites) Perp Lic E-RTU	<b>Q0T90AAE</b>
HPE ContexNet vE-CPE SFC Additional Small Site (Up to 100Mb/s) Perpetual License E-RTU	<b>Q0T91AAE</b>
HPE ContexNet vE-CPE SFC Additional Small Site (Up to 100Mb/s) Perpetual License E-RTU	<b>Q0T92AAE</b>
HPE ContexNet vE-CPE SFC Additional Large Site (Up to 10Gb/s) Perpetual License E-RTU	<b>Q0T93AAE</b>

**NOTE:** Product SKUs come bundled with 1 year, 24x7 standard support.

## Standard Features

<b>HPE OpenSDN Benefits</b>	<b>Carrier Class</b>	HPE OpenSDN delivers on unique Carrier requirements including high availability, performance & capacity, orchestration integration and the ability to deliver end-user services quickly, efficiently and customized per subscriber.
	<b>Distributed and Federated</b>	HPE OpenSDN implements federated control using a distributed mapping system, allowing for services to be distributed across multiple data centers and locations.
	<b>Mobility</b>	HPE OpenSDN implements an overlay abstraction network that allows mobility of users, VMs content or any other endpoint. The overlay shields ContextNet from the states of the underlying network switches and routers.
	<b>Open Source Based</b>	HPE OpenSDN is implemented based on the OpenDaylight SDN Controller framework leveraging innovation from multiple sources.
	<b>Standard protocols</b>	HPE OpenSDN implements standard architectures and protocols both internally and externally, including ETSI NFV, NVO3, OpenFlow, OVSDB and others.
<b>Key Product Features</b>	<b>Reliability and availability</b>	<ul style="list-style-type: none"><li>• All active redundancy</li><li>• External link protection</li><li>• Multiple copies of data in memory database with disk storage for persistence</li><li>• Rules persistence for fast restart</li><li>• Data caching in every node</li></ul>
	<b>AAA</b>	<ul style="list-style-type: none"><li>• RADIUS</li><li>• Diameter Gx</li><li>• Diameter Sd</li></ul>
	<b>Programmatic interfaces</b>	<ul style="list-style-type: none"><li>• Controller – OpenDaylight-based</li><li>• SDN protocols: OpenFlow 1.3</li><li>• RESTful interface</li><li>• CLI</li></ul>
	<b>Element and network management</b>	<ul style="list-style-type: none"><li>• CLI and GUI for comprehensive configuration and monitoring</li><li>• Software installation, upgrade, and rollback</li><li>• SNMP</li><li>• Extensive logging</li></ul>

## Service and Support and Warranty Information

### Software Support

HPE OpenSDN is available with four choices for support:

Support Level	Details
9 x 5 Standard	Hewlett Packard Enterprise will respond within 2 hours to critical cases received weekdays from 8am-5pm (local time), excluding Hewlett Packard Enterprise holidays. Cases received outside that window will be replied to on the next Hewlett Packard Enterprise business day.
24 X 7 Standard	Hewlett Packard Enterprise will respond to received critical cases within 1 hour. This coverage applies 24 hours per day, 365 days per year.
24 x 7 Enhanced	Hewlett Packard Enterprise will respond to received critical cases within 30 minutes. Also, quicker response and resolution times as compared to standard support. This coverage applies 24 hours per day, 365 days per year.

HPE OpenSDN products are supported by HPE's Communications Solutions Business (CSB) group, providing troubleshooting, advice and assistance. The OpenSDN dedicated support is provided through a virtual team located around the world, available 24x7 (depending on the service level purchased). The OpenSDN support team is highly trained in areas of OpenStack technology, network virtualization, converged infrastructure, and complex solution interoperability.

Hewlett Packard Enterprise Worldwide Customer Service contact numbers are available at: <http://www.hpe.com/contact>

## Related Options

### HPE OpenSDN Professional Services

#### **HPE Professional Services for OpenSDN**

HPE has been helping customers deploy Software Defined Networking and Virtualized Network Functions solutions for years and our Professional Services teams have played a significant role in those successes. HPE Professional Services is a dedicated team of professional consultants available worldwide to accelerate and support SDN and NFV deployments in OpenStack cloud environments. These enterprise services are delivered by an experienced team of HPE cloud architects, technologists, and engineers with expertise in design, storage, networking, security, database, scalability, high availability, and other OpenStack-based services.

Customers will benefit from HPE's Professional Services for OpenSDN in the following ways:

- Drive innovation and faster time to market/service delivery by enabling early adoption of SDN and NFV technologies
- Mitigate risk by ensuring network virtualization based projects are implemented with industry best practices
- Integrate development and operations by leveraging a best-practice implementation of ContexNet based on virtual compute platforms
- Empower developers and operations to come together for building and deploying physical and virtual network functions leveraging highly scalable, highly available services with network virtualization and SDN
- Achieve operational excellence by leveraging HPE's experience in managing and supporting IT environments
- Impart product knowledge, industry expertise and extensive deployment experience in trainings to key stakeholders for faster deployment and successful operation of a complex virtual network environment.

---

## Technical Specifications

**Other product information**

Additional information is available on HPE OpenSDN web page, which is referenced at: [hpe.com/csp/nfv](http://hpe.com/csp/nfv)

---

**Environment-friendly Products and Approach**

**End-of-life Management and Recycling**

Hewlett Packard Enterprise offers end-of-life Hewlett Packard Enterprise product return, trade-in, and recycling programs in many geographic areas. For trade-in information, please go to <http://www.hpe.com/recycle>. To recycle your product, please go to: <http://www.hpe.com/recycle> or contact your nearest Hewlett Packard Enterprise sales office. Products returned to Hewlett Packard Enterprise will be recycled, recovered or disposed of in a responsible manner.

The EU WEEE directive (2002/95/EC) requires manufacturers to provide treatment information for each product type for use by treatment facilities. This information (product disassembly instructions) is posted on the Hewlett Packard Enterprise web site at: <http://www.hpe.com/recycle>. These instructions may be used by recyclers and other WEEE treatment facilities as well as Hewlett Packard Enterprise OEM customers who integrate and re-sell Hewlett Packard Enterprise equipment.

---

## Summary of Changes

Date	Version History	Action	Description of Change:
13-Feb-2017	From Version 3 to 4	Changed	Consolidated Data Center Networking App Pack content into OpenSDN QuickSpecs. Added SD – VPN app pack.
28-Nov-2016	From Version 2 to 3	Changed	The document change its name to HPE OpenSDN SFC
13-May-2016	From Version 1 to 2	Changed	Changes made to the entire file.
16-Feb-2016	Version 1	QS Creation	Document creation



**Sign up for updates**



© Copyright 2017 Hewlett Packard Enterprise Development LP. The information contained herein is subject to change without notice. The only warranties for Hewlett Packard Enterprise products and services are set forth in the express warranty statements accompanying such products and services. Nothing herein should be construed as constituting an additional warranty. Hewlett Packard Enterprise shall not be liable for technical or editorial errors or omissions contained herein.

The OpenStack word mark and the Square O Design, together or apart, are trademarks or registered trademarks of OpenStack Foundation in the United States and other countries, and are used with the OpenStack Foundation's permission."

Microsoft and Windows are US registered trademarks of Microsoft Corporation

VMware Trademark are US registered trademarks of VMware.

c04756599- 15482- Worldwide - V4 - 13-February-2017